

# 2022 BRAKE PADS AND SHOES FOR MOTORCYCLES, SCOOTERS, DIRT BIKES AND ATV/UTV

**ECE R90**

**sbs**  
GO AHEAD

HI-TECH BRAKE SOLUTIONS  
MADE IN EUROPE



SBSBRAKES.COM

THE  
FUTURE  
IS GREEN  
SEE PAGE 4

**sbs**  
GO AHEAD

HI-TECH BRAKE SOLUTIONS  
MADE IN EUROPE

## NEW! Brake into a greener future

Starting from 2022, SBS will transition both organic and sinter brake pad compounds into more environmentally friendly iron-based compounds.

- Optimized quality with renowned features, incl. NRS
- Improved performance (higher friction coefficient)
- The more sustainable choice in brake pads

... Read more about the greener future on page 4.



@sbsbrakes | sbsbrakes.com | #GoAhead

# HOW TO CHOOSE YOUR BRAKE PADS



# NEW! Get the brake feel you want!

Find the right brake pad compound for you and your bike with the new **Compound Selector** at [sbsbrakes.com](http://sbsbrakes.com)

THE RIGHT CHOICE FOR YOUR MOTORCYCLE AND YOUR RIDING STYLE.

1. Choose your motorcycle type "Street Motorcycles", "V-Twin / American Motorcycles", "Off Road / Motocross", "ATV / UTV", "Road Racing", "Street use - scooter".
2. Find your "Type of use" in the matching diagram.
3. Pick the compound matching your needs and requirements.
4. Go to the "Motorcycle Model Applications" section to find your bike and matching SBS brake pad numbers.

## STREET MOTORCYCLES

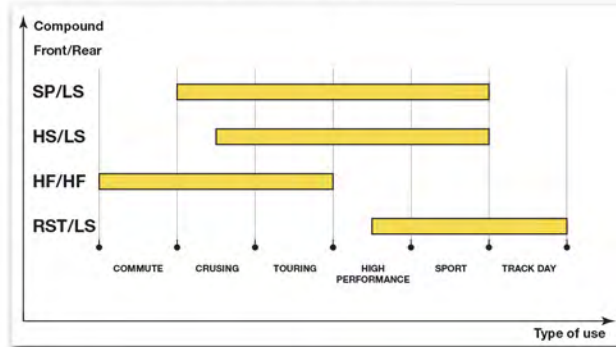

## V-TWIN / AMERICAN MOTORCYCLES

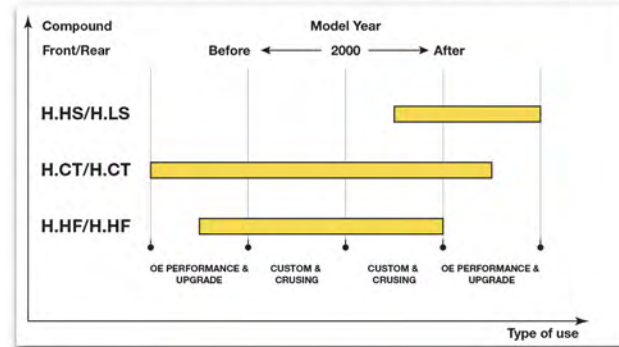

## OFF ROAD / MOTOCROSS

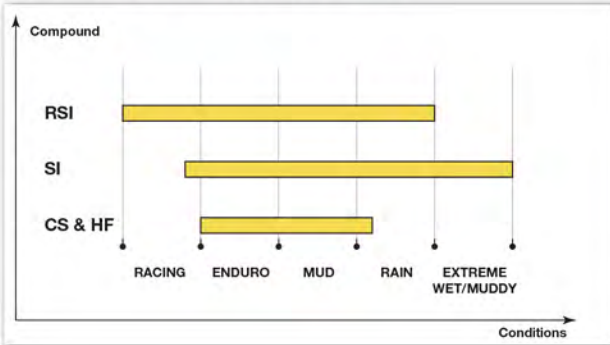

## ATV / UTV

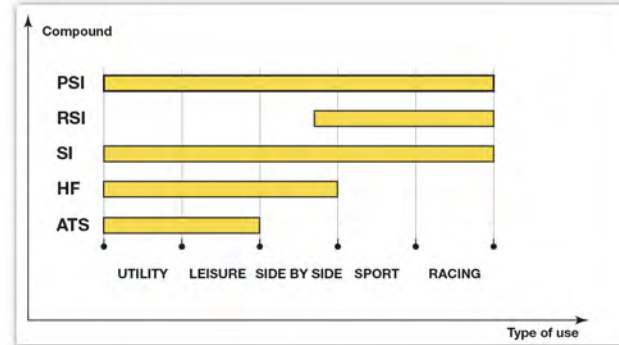

Choose ATS compound for older Arctic Cat and Polaris with plain steel discs.

## ROAD RACING

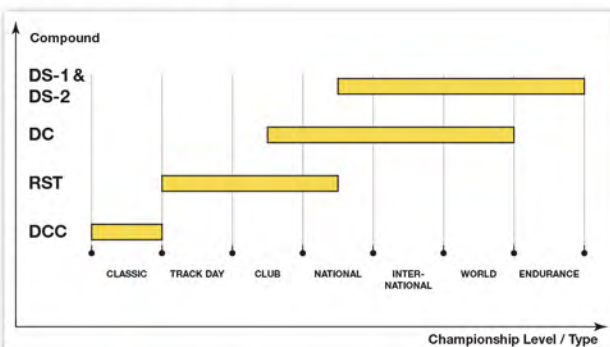

## STREET USE - SCOOTER

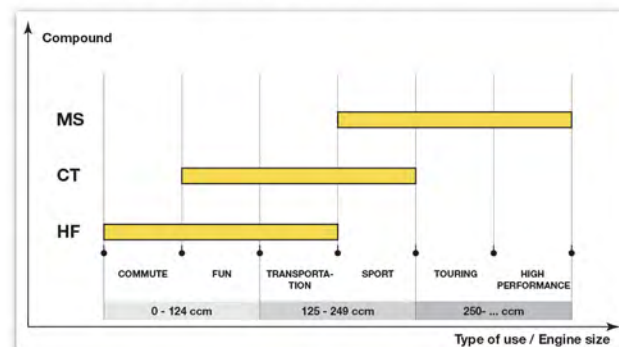

Find the right compound for you and your bike

Click Start Now, answer 2-3 questions and get the answer right away

START NOW



# CONTENT

2	WELCOME TO SBS
3	BRAKE PADS APPROVED ACCORDING TO ECE R90
4	NEW! BRAKE INTO A GREENER FUTURE
5 – 7	BRAKE PADS STREET
9 – 11	BRAKE PADS AMERICAN
13 – 15	BRAKE PADS SCOOTER
17 – 20	BRAKE PADS RACING
21 – 23	BRAKE PADS OFF ROAD & ATV/UTV
24	BRAKE SHOES WITH SPRINGS
25	BRAKE PINS STAINLESS
26	ACCESSORIES – BRAKE SYSTEM BLEEDER & ANTI-NOISE SHIMS
27 – 28	MERCHANDISE
29	DISPLAYS
30 – 31	FLYERS & POS MATERIAL
32	MODEL LOOK-UP WIDGET & COMPOUND SELECTOR WIDGET
33	MOTORCYCLE MODEL APPLICATIONS
34	<i>Motorcycles, Off Road, ATV/UTV, Scooters</i>
81	<i>Motocross</i>
87	<i>ATV / UTV</i>
103	<i>Racing</i>
107	<i>Calipers</i>
111	BRAKE PAD 1:1 DRAWINGS, COMPOUNDS, FITMENTS
611	BRAKE SHOE DRAWINGS, FITMENTS
653	CROSSLIST BRAKE PADS: SAME SHAPE – DIFFERENT THICKNESS
657	CROSS REFERENCE LIST – OE - SBS
669	BRAKE PIN FITMENTS, DRAWINGS

Make copies or extracts of this catalogue only with permission by SBS Friction A/S. The right to make modifications to the design or model application is reserved. Every effort has been made to ensure correctness of the information contained in this catalogue. However, we will not be responsible for any loss arising from errors or omissions made.

No se permite la copia total o parcial del catálogo sin el permiso de SBS Friction A/S. La empresa se reserva el derecho a realizar modificaciones en el diseño o aplicaciones para determinados modelos. Se ha realizado un gran esfuerzo para garantizar la exactitud de la información que se incluye en este catálogo. Sin embargo, no nos responsabilizaremos de las pérdidas ocasionadas por errores u omisiones.

## WELCOME TO SBS



SBS Friction A/S is a Danish-based company that develops, produces and markets brake pads and friction solutions for motorcycles, scooters, ATV/UTVs, special cars and industrial applications including wind turbines.

In addition, our product range includes other brake components such as brake rotors, brake shoes, and accessory parts such as brake pins.

Our history goes back to 1964. In the 1970s we were the first to introduce aftermarket disc brake pads for motorcycles. Since then we have continuously expanded our range, and our market coverage is almost complete no matter make, model or year. We are first with the newest and last with the oldest.

We are number #1 in the European aftermarket for motorcycle brake pads, and all over the globe the SBS name is known for braking excellence. Our total distribution network is spread to around 50 countries around the world including the USA, Canada, Japan, Australia, Singapore, South Africa and across the European Union.

Our customer portfolio comprises motorcycle industry OEMs such as brake system and vehicle manufacturers, and due to our friction knowhow, other industries such as wind turbines manufacturers.

Our headquarters, R&D, production and sales are located in Svendborg, Denmark. Our production plant features around 12,000 m<sup>2</sup> with production lines for ceramic, sintered and carbon material components.

We employ around 200 people and our inventory turnover has increased steadily since we introduced our first brake pad.

Just Go Ahead - We have the power to stop you!

## BIENVENIDO A SBS



SBS Friction A/S es una empresa danesa que desarrolla, fabrica y comercializa pastillas de freno y soluciones de fricción para motocicletas, scooter, ATV/UTV, coches especiales y aplicaciones industriales, incluidos generadores eólicos.

Nuestra gama de productos incluye también componentes como discos de freno, zapatas de freno y otros accesorios (por ejemplo, tornillos de freno).

Nuestra historia se remonta a 1964. En la década de 1970 fuimos los primeros en introducir las pastillas de freno de disco en el mercado de piezas de repuesto para motocicletas. Desde entonces hemos seguido ampliando nuestra gama de productos hasta cubrir la práctica totalidad del mercado, con independencia de la marca, el modelo o el año de fabricación. Somos los primeros en ofrecer las novedades y los últimos en retirar los productos más antiguos.

Además de ser el número 1 en el mercado europeo de piezas de repuesto para pastillas de freno de motocicletas, SBS es sinónimo de excelencia en sistemas de frenado en todo el mundo. Nuestra red de distribución se extiende por unos 50 países de todo el mundo, entre ellos Estados Unidos, Canadá, Japón, Australia, Singapur, Sudáfrica y toda la Unión Europea.

Nuestra cartera de clientes incluye fabricantes de equipos originales para motocicletas (por ejemplo, sistemas de frenos) y fabricantes de vehículos, además de fabricantes de otros sectores de la industria, como fabricantes de generadores eólicos, gracias a nuestros conocimientos específicos en materia de fricción.

En nuestra sede de Svendborg (Dinamarca) se encuentran los departamentos de I+D, producción y ventas. Nuestra planta de cerca de 12 000 m<sup>2</sup> incorpora líneas de producción de componentes de material cerámico, sinterizado y carbono.

Nuestra plantilla está integrada por cerca de 200 empleados y nuestra facturación ha aumentado de manera constante desde que presentamos nuestra primera pastilla de freno. En la actualidad somos líderes del mercado.

Adelante. Tenemos la fuerza para detenerle.



## BRAKE PADS APPROVED ACCORDING TO ECE R90



The ECE R90 regulation specifies design, construction, and performance requirements and test protocols for replacement brake parts for road-approved motor vehicles.

SBS has as an industry first received full approval according to the new ECE R90 regulation. You can see on the product pages (pages 5 – 23) which ones are marked “ECE R90 approved”. All future introductions are designed to meet the approval of the ECE R90 regulation.

### Your safety – your benefits

ECE R90 tests speed sensitivity and cold performance. Since the lining is part of the braking system converting the vehicle’s kinetic energy into heat, the lining must be capable of surviving high temperatures without excessive wear (leading to frequent replacement) or outgassing (which causes brake fade, a decrease in the stopping power of the brake).

Furthermore, ECE R90 requires correct marking of the products and sealed packaging.

A factory & test equipment approval is also part of the R90 homologation. It involves a once-a-year inspection and accreditation by engineers. SBS, of course, holds the approval for both manufacturing and testing facilities.

Type-approval to ECE R90 is required for all replacement brake linings throughout the European Union and in non-European countries that have adopted ECE Regulations.

### How to test – the practicalities

The brake pads are divided into 3 categories – A, B and C - depending on the friction material, and all compounds are tested individually.

All vehicles recommended for the specific brake pad compound must be calculated according to kinetic energy to find the most severe vehicle for testing.

This way, all compounds and vehicles are checked and the most severe combinations tested on track, for the consumer to get a very safe and secure product.

In short: your guarantee for reliable OEM replacement quality.

**When you choose an Aftermarket replacement brake pad, we strongly recommend you check that the ECE R90 approval has been granted. With SBS you are safe – all our street use materials have been fully approved for all shapes, vehicle applications and compounds. Contact our Customer Service for more information: [sbs@sbs.dk](mailto:sbs@sbs.dk)**

## PASTILLAS DE FRENO CON HOMOLOGACIÓN ECE R90



En el reglamento ECE R90 se especifican tanto los requisitos de diseño, fabricación y rendimiento como los protocolos de prueba de las piezas de los frenos de recambio de los vehículos de motor que circulan por carretera.

En SBS hemos sido los primeros en obtener plena homologación con arreglo al nuevo reglamento ECE R90. En las páginas de producto (páginas 5 – 23) pueden verse los que están marcados con “Homologación ECE R90”. Las futuras incorporaciones se diseñarán de manera que cumplan los requisitos de homologación del reglamento ECE R90.

### Su seguridad, su beneficio

El reglamento ECE R90 pone a prueba la sensibilidad a la velocidad y el rendimiento en frío. Como la guarnición forma parte del sistema de frenado y convierte la energía cinética del vehículo en calor, la guarnición debe ser capaz de resistir altas temperaturas sin que se produzca un desgaste excesivo (lo que conlleva sustituciones frecuentes) o desgasificación (causante del desvanecimiento de los frenos, equivalente a una reducción de la potencia de frenado del freno).

Asimismo, el reglamento ECE R90 exige que los productos estén marcados de manera correcta y se precinten los envases.

La aprobación de la fábrica y el equipo de prueba también forman parte de la homologación R90. Esto conlleva la inspección y la acreditación de la fábrica una vez al año por parte de ingenieros. Las instalaciones de pruebas y fabricación de SBS están homologadas.

En la Unión Europea y en los países extraeuropeos que hayan adoptado los reglamentos ECE se exige que las guarniciones de los frenos de recambio tengan la homologación ECE R90.

### Cómo se prueban: aspectos prácticos

Las pastillas de freno se dividen en 3 categorías (A, B y C) dependiendo del área del material de fricción y todos los compuestos se prueban por separado.

En todos los vehículos en los que se recomiendan pastillas de freno concretas, el compuesto debe calcularse en función de la energía cinética para encontrar el vehículo con condiciones más estrictas para las pruebas.

De esta forma, se comprueban todos los compuestos y vehículos y se prueban en pista las combinaciones más exigentes con el fin de ofrecer al consumidor un producto muy seguro y estable.

En resumen, se garantiza un recambio OEM fiable y de calidad.

**Al elegir una pastilla de freno posventa, recomendamos encarecidamente que cuente con la homologación ECE R90. Con SBS tiene la seguridad de que todos nuestros materiales para uso en la circulación se han homologado completamente en todas las formas, aplicaciones de vehículos y compuestos. Póngase en contacto con nuestro Servicio de atención al cliente para obtener más información: [sbs@sbs.dk](mailto:sbs@sbs.dk)**



## NEW! BRAKE INTO A GREENER FUTURE



A brake pad is not just a brake pad. It is what enables riders all over the World, to go ahead and seek the adventures and freedom they desire. No matter what they ride and where they ride it. Because they know SBS will stop the bike when they want.

Now, that freedom can be reached with more sustainable and environmentally friendly brake pads.

Starting from 2022 - as industry-first - SBS will transition more than 95% of its brake pad range through increasingly sustainable processes and use of materials. The transition will start with the organic range in 2022. Sinter range will follow from 2023. This journey will lead to the progressive replacement of the Aftermarket pad range by 2024, while also be subject to OEM.

### What you are to expect

Optimized quality features, improved performance, and the well-known SBS reliability ...only better for the environment. Always expect braking excellence in SBS brake pads. #GoAhead

For more information, see: [sbsbrakes.com/green](https://sbsbrakes.com/green)

## ¡NOVEDAD! FRENAR POR UN FUTURO MÁS ECOLÓGICO



Una pastilla de freno no es solamente eso. Es lo que permite a los conductores de todo el mundo seguir adelante en busca de las aventuras y la libertad que desean. Conduzcan lo que conduzcan y en cualquier lugar. Porque saben que SBS detendrá la moto cuando quieran.

Esa libertad ya se puede alcanzar con unas pastillas de freno más sostenibles y respetuosas con el medio ambiente.

A partir de 2022, SBS será la primera del sector en efectuar la transición de más del 95 % de su gama de pastillas de freno a través de procesos y un uso de materiales cada vez más sostenibles. La transición empezará con la gama ecológica en 2022. La gama sinterizada seguirá en 2023. Este proceso conllevará la sustitución progresiva de la gama de pastillas posventa en 2024, de acuerdo también con los fabricantes de equipos originales (OEM).

### Cuáles son las expectativas

Óptima calidad, mayores prestaciones y la reconocida fiabilidad de SBS... pero mejores para el medio ambiente. Siempre puede esperar la excelencia de unas pastillas de freno SBS. #GoAhead

Para obtener más información, visite: [sbsbrakes.com/green](https://sbsbrakes.com/green)

Watch the movie:



Vea el vídeo:

# LICENSE TO ADVENTURE

## #STREETMOTORCYCLE



If a street bike is your favorite. If you are dedicated to touring and adventures on weekends and holidays. If you enjoy the freedom of motorcycle riding. Or if you are commuting every day.

Then SBS STREET brake pads are the right choice for you. Our STREET compounds are developed to match all makes, models and year of street bikes on the market – front and rear.

All brake pads are ECE R90 approved.

They give you the performance, durability and comfort that you need to GO AHEAD.

Choose between:

- // PERFORMANCE – HS / LS
- // PERFORMANCE UPGRADE – SP
- // STANDARD – HF

Follow our recommendations for the ideal pads for your bike.



Si prefiere la motocicleta de calle. Si reserva los fines de semana y las vacaciones para el turismo y la aventura. Si disfruta de la libertad que da pilotar una motocicleta. O si utiliza la motocicleta a diario.

Entonces, las pastillas de freno SBS STREET son perfectas para usted. Nuestros compuestos STREET se adecuan a motocicletas de calle de todas las marcas, modelos y años que hay en el mercado, sin excepción.

Todas las pastillas de freno tienen la homologación ECE R90.

Ofrecen el rendimiento, la duración y el confort que necesita para SEGUIR ADELANTE.

Puede elegir entre:

- // PERFORMANCE – HS / LS
- // PERFORMANCE UPGRADE – SP
- // STANDARD – HF

Para acertar con las pastillas de su motocicleta, siga nuestras recomendaciones.

**sbs**<sup>®</sup>  
GO AHEAD



# PERFORMANCE



**R90**

## HS - SINTER

FRONT / DELANTE



- // OE replacement compound for bikes with sintered pads
- // Designed for modern high performance, sport, big touring and adventure bikes
- // Sintered compound formulated for low wear, high thermal stability, excellent brake feel and easy modulation
- // HH rated performance, developed in racing and fine-tuned for street use
- // Excellent for stainless steel or cast iron brake rotors
- // Front (HS) and rear (LS) compounds for ideal brake balance, to avoid over-braking of rear-wheel



- // Compuesto de recambio original y mejorado para motocicletas con pastillas sinterizadas
- // Diseñado para utilizarse en motocicletas modernas de altas prestaciones, deportivas, gran turismo y adventure
- // Compuesto sinterizado formulado para garantizar poco desgaste, alta estabilidad térmica, excelente sensación de frenado y fácil modulación
- // Líder en el sector y alto rendimiento, desarrollado en competición y adaptado para el uso en la calle
- // Excelente para rotores/discos de freno de acero inoxidable o hierro fundido
- // Compuestos delantero (HS) y trasero (LS) que permiten un reparto de la frenada perfecto para evitar el bloqueo de la rueda trasera



Brake performance diagrams to be compared individually within STREET compounds only.



**R90**

## LS - SINTER

REAR / POSTERIOR



- // OE replacement compound for bikes with sintered pads
- // Designed for modern high performance, sport and big touring bikes
- // Sintered compound offering predictable and controllable performance for rear wheel use
- // Exclusive rear wheel compound formulated according to OEM concept offering ideal front/rear brake balance, to avoid over-braking of rear-wheel



- // Compuesto de recambio original para motocicletas con pastillas sinterizadas
- // Diseñado para utilizarse en motocicletas modernas de altas prestaciones, motocicletas deportivas y gran turismo
- // Compuesto sinterizado que ofrece resultados predecibles y controlables en la rueda trasera
- // Exclusivo compuesto para la rueda trasera formulado según el concepto del fabricante original, que ofrece un perfecto reparto de la frenada entre la parte delantera y la trasera para evitar frenadas bruscas y el bloqueo de la rueda trasera



Diagramas de potencia de freno para comparar de forma individual los compuestos de STREET exclusivamente.





# PERFORMANCE UPGRADE / STANDARD



## SP - EVO SINTER

FRONT / DELANTE



- // OE replacement and upgrade compound for modern cruisers, sport, adventure & touring bikes
- // State-of-the-art conductive sintered EVO compound formulated for strong initial bite to give instant brake feel, easy modulation and powerful in-stop performance
- // Fade free, consistent and reliable performance under extreme riding conditions and throughout brake pad lifetime
- // High thermal stability in combination with long pad durability and very low brake rotor wear
- // Exceeds HH friction rating
- // NUCAP NRS technology secures a mechanical and indestructible bonding of the compound – first time ever used on a sinter compound pad
- // Front (SP) and rear (LS) compounds for ideal brake balance, to avoid over-braking of rear-wheel



- // Compuesto de recambio original y mejorado para motocicletas modernas adventure y cruisers, de altas prestaciones, para carretera, deportivas y de turismo
- // Compuesto EVO con sinterizado conductivo de vanguardia, formulado para lograr una mordida inicial enérgica con sensación inmediata de frenado, fácil modulación y altas prestaciones en las paradas
- // Resistente al desgaste con rendimiento constante y fiable en condiciones de conducción extremas y durante toda la vida útil de la pastilla de freno
- // Alta estabilidad térmica junto con larga duración de la pastilla y desgaste del disco de freno muy reducido
- // Tecnología NUCAP NRS que garantiza una adherencia mecánica e indestructible del compuesto
- // Compuestos delantero (SP) y trasero (LS) que permiten un reparto de la frenada perfecto para evitar el bloqueo de la rueda trasera



Brake performance diagrams to be compared individually within STREET compounds only.



## HF - CERAMIC

FRONT / DELANTE • REAR / POSTERIOR



- // OE replacement compound for bikes with non-sintered pads
- // Designed for commuters, general-purpose street and cruiser bikes
- // Ceramic compound offers long pad life, low dust and low brake rotor wear
- // Excellent, consistent performance in wet and dry conditions
- // NUCAP NRS technology secures a mechanical and indestructible bonding of the compound
- // Innovative noise-reduction technology for high comfort and low development of noise



- // Compuesto de recambio original para motocicletas con pastillas no sinterizadas
- // Diseñado para motocicletas urbanas, motocicletas de calle polivalentes y cruisers,
- // Compuesto cerámico que garantiza una larga duración de la pastilla, poco polvo y un menor desgaste del rotor/disco de freno
- // Prestaciones excelentes y uniformes tanto en seco como en mojado
- // Tecnología NUCAP NRS que garantiza una adherencia mecánica e indestructible del compuesto
- // Innovadora tecnología de reducción del ruido que mejora el confort y reduce la emisión de ruido

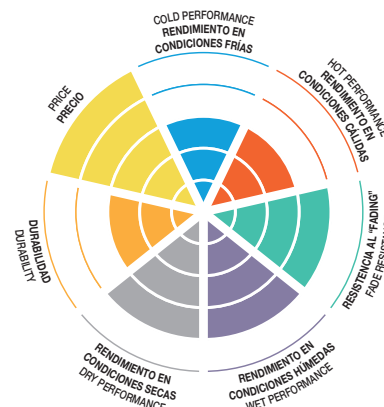

Diagrams de potencia de freno para comparar de forma individual los compuestos de STREET exclusivamente.





# LICENSE TO FREEDOM

## #VTWIN



If you have a passion for the American lifestyle, and the unique design and characteristics of the famous American motorcycle brands such as Harley Davidson, Victory and Indian, then SBS has the answer to your brake needs.

Our range of brake pads developed especially for American-made motorcycles features compounds that unite high power with low noise and long lifetime. Our range has full coverage - vintage models back from the 80s as well as brand new American-built bikes.

All brake pads are ECE R90 approved.

Choose between:

- // HIGH PERFORMANCE & NO DUST – H.HS / H.LS
- // HIGH POWER & NOISE REDUCTION FORMULA – H.CT
- // ULTRA QUIET & LOW DUST – H.HF

Follow our recommendations for the ideal pads for your bike.



Si le apasiona el estilo de vida americano y el diseño y las características exclusivas de marcas de motocicletas tan legendarias como Harley Davidson, Buell e Indian, SBS tiene los frenos que necesita.

Nuestra gama de pastillas de freno creada especialmente para las motocicletas americanas incorpora compuestos que combinan alta potencia con poco ruido y larga vida útil. Nuestra gama abarca tanto los modelos clásicos de la década de 1980 como los modelos más modernos de motocicletas americanas.

Todas las pastillas de freno tienen la homologación ECE R90.

Puede elegir entre:

- // HIGH PERFORMANCE & NO DUST – H.HS / H.LS
- // HIGH POWER & NOISE REDUCTION FORMULA – H.CT
- // ULTRA QUIET & LOW DUST – H.HF

Para acertar con las pastillas de su motocicleta, siga nuestras recomendaciones.



GO AHEAD



# HIGH PERFORMANCE & NO DUST



## H.HS - SINTER

FRONT / DELANTE



- // OE replacement HH rated compound for bikes with sintered pads
- // Designed for modern high performance, sport and big touring bikes
- // Sintered compound formulated for low wear, high thermal stability and excellent brake feel
- // Excellent for stainless steel or cast iron brake rotors and keeps your whitewalls clean
- // Front (H.HS) and rear (H.LS) compounds for ideal brake balance, to avoid over-braking of rear-wheel



- // Compuesto de recambio original y mejorado para motocicletas con pastillas sinterizadas
- // Diseñado para utilizarse en motocicletas modernas de altas prestaciones, motocicletas deportivas y gran turismo
- // Compuesto sinterizado formulado para garantizar poco desgaste, alta estabilidad térmica y excelente sensación de frenado
- // Excelente para rotores/discos de freno de acero inoxidable o hierro fundido
- // Compuestos delantero (H.HS) y trasero (H.LS) que permiten un reparto de la frenada perfecto para evitar el bloqueo de la rueda trasera



Brake performance diagrams to be compared individually within AMERICAN compounds only.



## H.LS - SINTER

REAR / POSTERIOR



- // OE replacement compound for bikes with sintered pads
- // Designed for modern high performance, sport and big touring bikes
- // Sintered compound offering predictable and controllable performance for rear wheel use
- // Exclusive rear-wheel compound formulated according to OEM concept, to offer ideal front/rear brake balance, to avoid over-braking of rear-wheel



- // Compuesto de recambio original para motocicletas con pastillas sinterizadas
- // Diseñado para utilizarse en motocicletas modernas de altas prestaciones, motocicletas deportivas y gran turismo
- // Compuesto sinterizado que ofrece resultados predecibles y controlables en la rueda trasera
- // Exclusivo compuesto para la rueda trasera formulado según el concepto del fabricante original, que ofrece un perfecto reparto de la frenada entre la parte delantera y la trasera para evitar frenadas bruscas y el bloqueo de la rueda trasera

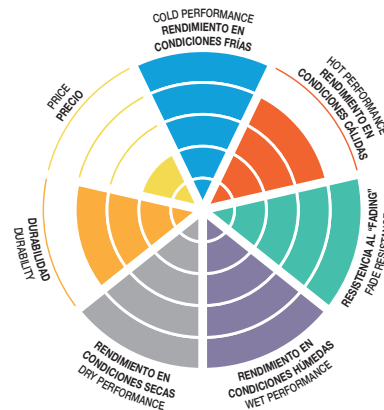

Diagramas de potencia de freno para comparar de forma individual los compuestos de AMERICAN exclusivamente.



AMERICAN BRAKE PADS



# HIGH POWER & NOISE REDUCTION FORMULA / ULTRA QUIET & LOW DUST



## H. CT - CARBON

FRONT / DELANTE • REAR / POSTERIOR



- // Performance upgrade compound, excellent for bikes with customized brake system and rotors
- // Compatible with stainless steel, cast iron, chromed and polished brake rotors
- // HH-rated performance, developed in racing and fine-tuned for street use
- // Unmatched feel and control at brake lever in wet and dry conditions
- // NUCAP NRS technology secures a mechanical and indestructible bonding of the compound
- // Noise reduced



- // Compuesto con mejora de rendimiento, excelente para motocicletas con discos y sistemas de frenos personalizados
- // Compatible con discos de freno de acero inoxidable, hierro fundido, cromados y pulidos
- // Prestaciones HH, desarrollado en competición y adaptado para el uso en la calle
- // Sensación y control inigualables en la maneta de freno tanto en seco como en mojado
- // Tecnología NUCAP NRS que garantiza una adherencia mecánica e indestructible del compuesto
- // Ruido reducido

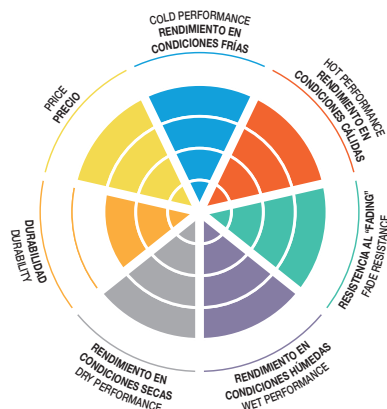

Brake performance diagrams to be compared individually within AMERICAN compounds only.



## H. HF - CERAMIC

FRONT / DELANTE • REAR / POSTERIOR



- // OE replacement compound for bikes with non-sintered pads
- // Designed for commuters, general-purpose street and cruiser bikes
- // Ceramic compound offers long pad life, low dust and low brake rotor/rotor wear
- // Excellent, consistent performance in wet and dry conditions
- // NUCAP NRS technology secures a mechanical and indestructible bonding of the compound
- // Innovative noise-reduction technology for high comfort and low development of noise



- // Compuesto de recambio original para motocicletas con pastillas no sinterizadas
- // Diseñado para motocicletas urbanas, motocicletas de calle polivalentes y cruisers
- // Compuesto cerámico que garantiza una larga duración de la pastilla, poco polvo y un menor desgaste del rotor/disco de freno
- // Prestaciones excelentes y uniformes tanto en seco como en mojado
- // Tecnología NUCAP NRS que garantiza una adherencia mecánica e indestructible del compuesto
- // Innovadora tecnología de reducción del ruido que mejora el confort y reduce la emisión de ruido

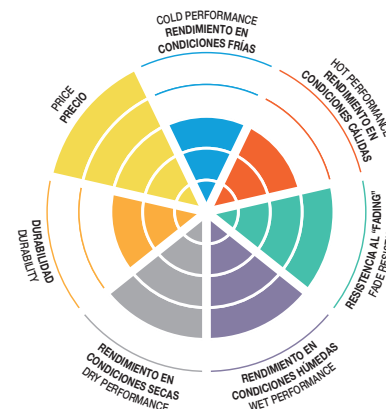

Diagramas de potencia de freno para comparar de forma individual los compuestos de AMERICAN exclusivamente.



# LICENSE TO HAVE FUN

## #URBANMOBILITY



When it comes to city traffic, a scooter is often the ideal vehicle. In dense traffic you have to rely on your brakes. The SBS scooter brake pads offer the ideal brake performance and durability for this environment.

We offer different compounds for different kinds of scooters and riding needs. Our market coverage is wide with pads and compounds to fit small 50 cc models all the way to modern, high-performance maxi scooters.

Most brake pads are ECE R90 approved.

Choose between:

- // MAXI SINTER – MS
- // STANDARD & MAXI – CT
- // STANDARD & MAXI – HF

Follow our recommendations for the ideal pads for your scooter.



El scooter suele ser el vehículo perfecto para desplazarse por la ciudad. Con tráfico denso, es esencial disponer de unos frenos fiables. Las pastillas de freno para scooter de SBS ofrecen unas prestaciones de frenado y una durabilidad perfectas en ciudad.

Ofrecemos compuestos diferentes que se adecuan a la mayoría de los tipos de scooter y de las necesidades de conducción. Tenemos una oferta comercial amplia que incluye pastillas y compuestos para diferentes modelos, desde scooters pequeños de 50 cc hasta maxi scooters modernos de altas prestaciones.

La mayoría de las pastillas de freno tienen la homologación ECE R90.

Puede elegir entre:

- // MAXI SINTER – MS
- // STANDARD & MAXI – CT
- // STANDARD & MAXI – HF

Para acertar con las pastillas de su scooter, siga nuestras recomendaciones.

**sbs**<sup>®</sup>  
GO AHEAD



# MAXI SINTER / STANDARD & MAXI



## MS - SINTER

FRONT / DELANTE • REAR / POSTERIOR



- // High performance upgrade sintered compound for Maxi scooters from 250 cc and up
- // Recommended for Maxi scooters equipped with motorcycle technology
- // State-of-the-art sintered compound formulated for low wear, high thermal stability and excellent brake feel



- // Compuesto sinterizado mejorado de alto rendimiento para maxi scooters (de 250 cc en adelante)
- // Recomendado para maxi scooters con tecnología de motocicleta
- // Compuesto sinterizado de vanguardia formulado para garantizar poco desgaste, alta estabilidad térmica y excelente sensación de frenado

## CT - CARBON

FRONT / DELANTE • REAR / POSTERIOR



- // Performance upgrade carbon compound for medium size scooters 125-249 cc
- // Recommended for sporty riding, everyday transportation and fun
- // NUCAP NRS technology secures a mechanical and indestructible bonding of the compound



- // Compuesto de carbono con mejora de rendimiento para scooters de tamaño mediano (125-249 cc)
- // Recomendado para pilotaje deportivo, transporte diario y entretenimiento
- // Tecnología NUCAP NRS que garantiza una adherencia mecánica e indestructible del compuesto



Brake performance diagrams to be compared individually within SCOOTER compounds only.



Diagramas de potencia de freno para comparar de forma individual los compuestos de SCOOTER exclusivamente.





SCOOTER BRAKE PADS

# STANDARD & MAXI



## HF - CERAMIC

FRONT / DELANTE • REAR / POSTERIOR



- // OE replacement ceramic compound for small and medium size scooters 50-124 cc
- // Recommended for commuters and general-purpose street riding
- // NUCAP NRS technology secures a mechanical and indestructible bonding of the compound



- // Compuesto cerámico de recambio original para scooters de tamaño pequeño y mediano (50-124 cc)
- // Recomendado para pilotar motocicletas urbanas y motocicletas de calle polivalentes
- // Tecnología NUCAP NRS que garantiza una adherencia mecánica indestructible del compuesto

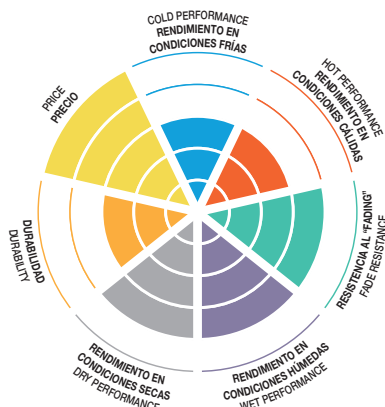

Brake performance diagrams to be compared individually within SCOOTER compounds only.



Diagramas de potencia de freno para comparar de forma individual los compuestos de SCOOTER exclusivamente.

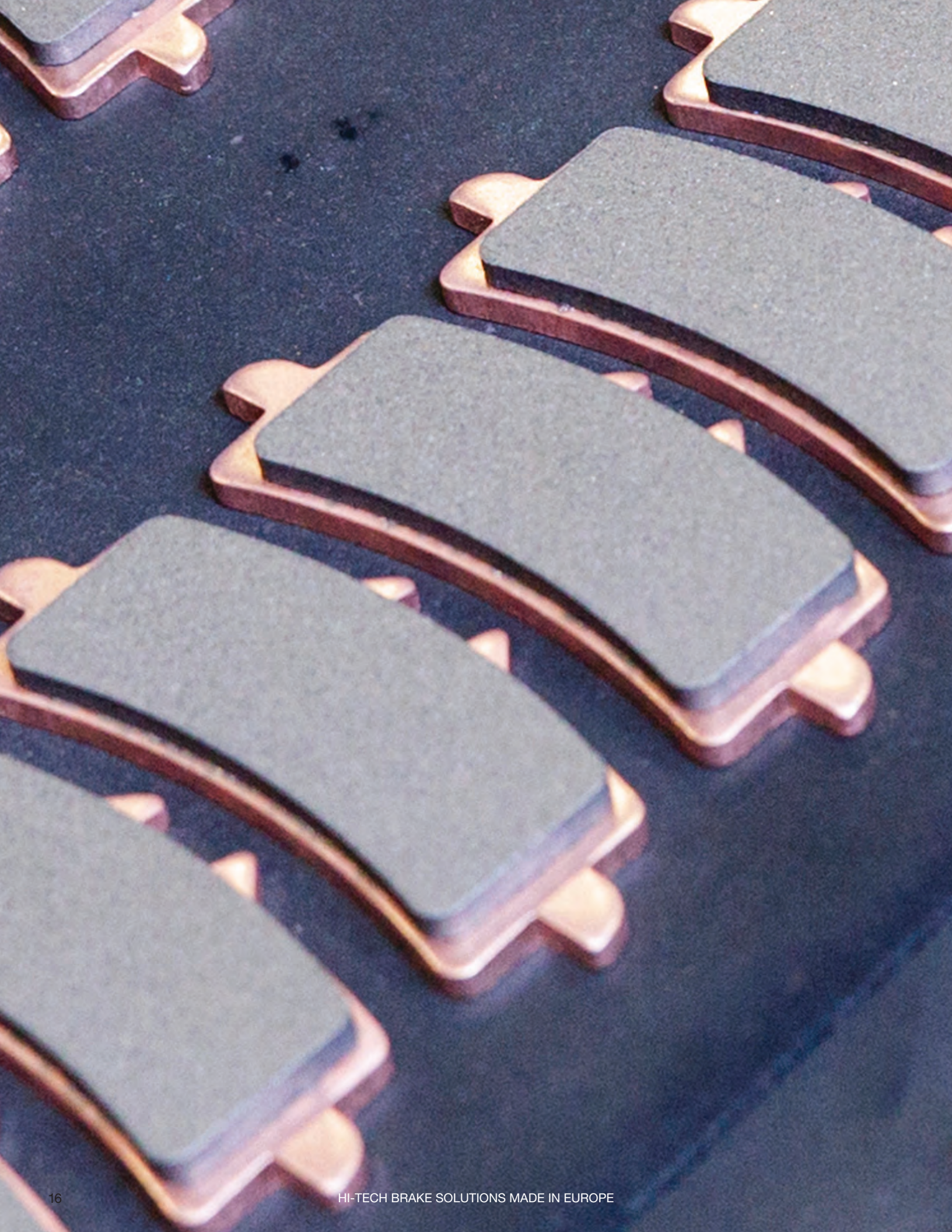

# LICENSE TO WIN

## #ROADRACING



KENAN SOFUOGLU



For more than 25 years racing has been part of our DNA.

Through our Partners in Racing concept, we deliver the stopping power to the best of the best in racing. Whether it comes to international top level road racing such as World Superbike, Supersport, Endurance, The Isle of Man TT, National competitions, track days or classic road racing, SBS offers you the brake pads you need for gaining that important 100th of a second over the competition. Our race compounds are specially developed for competition and race track use – tested and approved by some of the best World Championship riders.

Full blood race pads cannot be ECE R90 approved. All racing pads other than LS are enforced with NUCAP NRS technology.

Choose between:

- // DYNAMIC RACING CONCEPT – DS-1 & DS-2
- // ROAD RACING & CLASSIC RACING – DC / DCC
- // ROAD RACING & TRACK DAYS – RST
- // RACING REAR – RQ / LS

Follow our recommendations for the ideal pads for your bike.



Las carreras forman parte de nuestro ADN desde hace más de 25 años.

A través de nuestros colaboradores del Racing concept, ofrecemos potencia de frenado a los mejores pilotos de competición del mundo. Ya se trate carreras internacionales de primer nivel, como Superbike, Supersport o Endurance, competiciones nacionales, tandas en circuito o carreras clásicas en carretera, SBS ofrece pastillas de freno con las que se pueden ganar centésimas de segundo importantes durante la frenada. Nuestros compuestos de carreras se han desarrollado especialmente para el uso en competición y en circuitos de carreras. Han sido probados y aprobados por algunos de los mejores pilotos del Campeonato del Mundo.

Las pastillas de carreras no pueden tener la homologación ECE R90. Salvo LS, todas las pastillas de carreras se realizan con tecnología NUCAP NRS.

Puede elegir entre:

- // DYNAMIC RACING CONCEPT – DS-1 & DS-2
- // ROAD RACING & CLASSIC RACING – DC / DCC
- // ROAD RACING & TRACK DAYS – RST
- // RACING REAR – RQ / LS

Para acertar con las pastillas de su motocicleta, siga nuestras recomendaciones.



GO AHEAD



# ROAD RACING & ENDURANCE / ENDURANCE, CLASSIC RACING & ROAD RACING



RACING  
ROAD RACING



## DS-1 & DS-2 DYNAMIC RACING CONCEPT

FRONT / DELANTE - FOR RACE USE ONLY



- // The choice of numerous World Champions in Superbike, Supersport, Moto2 and Endurance
- // High-tech sintered compound available for racing & standard brake systems used in racing
- // DS-1 with an aggressive initial bite features and linear predictable in-stop performance
- // DS-2 with a smooth initial bite and progressive in-stop performance
- // A combination (left and right) of the two compounds makes fine tuning of braking performance possible
- // NUCAP NRS technology secures mechanical bonding



- // La alternativa elegida por numerosos campeones del mundo de Superbike, Supersport, Moto2 y Resistencia
- // Compuesto sinterizado de alta tecnología disponible para sistemas de frenos de carreras y convencionales que se usan en competición
- // DS-1: Si se prefiere una fuerte mordida inicial y un rendimiento gradual
- // DS-2: Si se prefiere una mordida inicial suave y un rendimiento progresivo
- // Ahora es posible combinar los dos compuestos: Disco de freno izquierdo DS-1 y disco de freno derecho DS-2. Esto ofrece una combinación de las diferentes características de rendimiento de los dos compuestos. En definitiva, un ajuste fino del rendimiento de frenado según las preferencias de frenado de cada piloto
- // Tecnología NUCAP NRS que garantiza una adherencia mecánica e indestructible del compuesto



Brake performance diagrams to be compared individually within RACING compounds only.



## DC - DUAL CARBON

FRONT / DELANTE - FOR RACE USE ONLY



- // The upgrade choice for Superbike, Supersport and Superstock racers in National Championship as well as for Track Day riders
- // High-tech carbon compound developed for racing and standard brake systems used for race and sport bikes
- // Low heat transfer rate protects brake system and brake fluid against extreme temperatures
- // Smooth initial bite, progressive in-stop performance with excellent brake lever feel and modulation
- // DEST technology used for pre-bedding of the compound to eliminate fade and secure consistent performance
- // NUCAP NRS technology secures a mechanical and indestructible bond between the compound and backing plate
- // Laser cut backing plate to prevent deformation



- // La alternativa mejorada para pilotos de Superbike, Supersport y Superstock que corren en campeonatos nacionales así como para las tandas en circuitos
- // Compuesto de carbono de alta tecnología desarrollado para sistemas de frenos de carreras y convencionales que se utilizan en motocicletas de carreras y deportivas
- // Bajo coeficiente de transferencia de calor que protege el sistema de frenos y el líquido de frenos frente a las temperaturas extremas
- // Mordida inicial suave y rendimiento en parada progresivo con modulación y sensibilidad excelentes en la maneta de freno
- // Uso de la tecnología DEST para lograr el preasentamiento del componente con el fin de evitar el desgaste y garantizar un rendimiento constante
- // Tecnología NUCAP NRS que garantiza una adherencia mecánica e indestructible del compuesto



Diagrams de potencia de freno para comparar de forma individual los compuestos de RACING exclusivamente.



# ENDURANCE, CLASSIC RACING & ROAD RACING / ROAD RACING & TRACKDAYS



## RACING CLASSIC ROAD RACING

### DCC - DUAL CARBON

FRONT / DELANTE - FOR RACE USE ONLY



- // The choice for classic road racing derived from more than 25 years of experience in World Championship racing and inspired by our championship winning DC Dual Carbon material
- // Smooth initial bite, ideal for classic front fork construction and tires. Progressive brake performance offering superior power and front-end feel
- // Thermal stability, suitable for single or dual rotor set-up. Compatible with stainless steel and cast iron brake rotors
- // Low thermal conductivity reduces thermal load to seals, brake fluid and caliper parts
- // DEST technology used for pre-bedding of the compound to eliminate fade and secure consistent performance
- // NUCAP NRS technology secures a mechanical and indestructible bonding of the compound
- // Laser cut backing plate to prevent deformation



- // La elección para carreras clásicas en carretera gracias a los más de 25 años de experiencia en el Campeonato del Mundo e inspirada en nuestro material DC (Dual Carbon), ganador del mundial
- // Mordida inicial suave, ideal para la configuración clásica de horquilla delantera y las llantas. Prestaciones de frenado progresivas con mayor potencia y mejor tacto en la rueda delantera
- // Estabilidad térmica, adecuada para la configuración de 1 y 2 discos. Compatible con discos de freno de hierro fundido y acero inoxidable
- // Escasa conductividad térmica que reduce la carga térmica en las juntas, el líquido de frenos y las pinzas de freno
- // Uso de la tecnología DEST para lograr el preasentamiento del componente con el fin de evitar el desgaste y garantizar un rendimiento constante
- // Tecnología NUCAP NRS que garantiza una adherencia mecánica e indestructible del compuesto



Due to the unique nature of the DCC compound, formulated especially for vintage racing, it is not possible to compare to other products.



El carácter singular del compuesto DCC no permite compararlo con otros productos, ya que se trata de un compuesto formulado especialmente para coches clásicos de carreras.



### RST - SINTER

FRONT / DELANTE



- // The ideal and affordable choice for track days and club racing. Can be used for street riding
- // Sintered compound available for modern sportbike standard brake systems
- // Excellent for stainless steel or cast iron brake rotors
- // Strong initial bite, linear in-stop performance with good brake feel and control

As of 2020 the RST range replaced RS pads 1:1, when it comes to specializing applications. However, with increased braking power and even better brake feel and control. Riders just have to be aware of a slightly increased bedding-in time compared to RS due to the increased durability. All RST pads are enforced with NRS. The NRS (Nucap Retention System) is an advanced mechanical bonding technology based on a matrix of steel hooks raised from the backing plate steel material. The NRS hooks mold into the friction material creating an indestructible and corrosion safe mechanical bond without any use of adhesives. Main advantages of NRS technology:

- // No separation between the back plate and friction material
- // No lifting edges of the friction material giving a firm lever feel
- // No vibration between the friction material and back plate



- // La elección perfecta y económica para las tandas en circuito y para motocicletas mixtas para circuito y carretera
- // Compuesto sinterizado disponible para los modernos sistemas de frenos convencionales de las motocicletas de competición y deportivas
- // Excelente para rotores/discos de freno de acero inoxidable o hierro fundido
- // Mordida inicial enérgica y rendimiento en parada gradual con buena sensación y control de frenado

A partir de 2020, la gama RST ha reemplazado a las pastillas RS 1:1 en cuanto a adaptación de aplicaciones. Sin embargo, ofrece mayor potencia de frenado e incluso mejor sensación y control de frenado. A los pilotos les basta saber que el tiempo de asentamiento es ligeramente mayor que en el caso de RS debido a la elevada durabilidad. Todas las pastillas RST se realizan con NRS. NRS (Nucap Retention System) es una tecnología de adherencia mecánica avanzada que se basa en una matriz de ganchos de acero construida a partir del material de acero de la placa posterior. Los ganchos NRS se adaptan al material de fricción y crean una unión mecánica anticorrosión e indestructible sin el uso de adhesivos. Principales ventajas de la tecnología NRS:

- // Ausencia de separación entre la placa posterior y el material de fricción
- // Ausencia de deformación de los bordes del material de fricción que proporciona sensación de firmeza
- // Ausencia de vibración entre el material de fricción y la placa posterior



## ENDURANCE, CLASSIC RACING & ROAD RACING



### RQ - CARBON TECH

REAR / POSTERIOR



- // Rear brake carbon compound with high brake performance
- // Excellent feel and control to use rear brake steering into turns and handle the bike out of turns



- // Compuesto de carbono para el freno trasero con altas prestaciones de frenado
- // Sensación y control excelentes para gestionar la frenada en curvas



### LS - SINTER

REAR / POSTERIOR



- // Rear brake sintered compound with medium brake performance and long pad life
- // Recommended for riders using the rear brake occasionally or only slightly entering the turns



- // Compuesto sinterizado para el freno trasero con prestaciones de frenado de nivel medio y larga duración de la pastilla
- // Recomendado para pilotos que utilizan el freno trasero de manera esporádica o ligeramente al entrar en curvas

# LICENSE TO ACTION

## #OFFROADBIKE



Enjoying the freedom in the desert. Conquering rocks and mountains. Racing down the dirt track for podium positions.

When riding off road is your passion, SBS offers you the ideal brake compound for the aggressive environment of sand, dust, mud and water. Whether on motorcycle, ATV or UTV.

Choose between our racing pads for competition at all levels or the alternatives when riding off road for leisure and fun. Our range covers all off road makes and models and of course for both front and rear applications.

Most brake pads are ECE R90 approved.

Choose between:

- // UPGRADE & RACING – RSI / PSI
- // CLUB, TRAILS & LEISURE – SI / CS / ATS

Follow our recommendations for the ideal pads for your bike.



Disfrutar de la libertad en el desierto. Conquistar colinas y montañas. Recorrer pistas de tierra a gran velocidad para llegar a lo más alto en las competiciones.

Si su pasión es el off-road, SBS ofrece el compuesto de freno ideal para entornos agresivos con gran cantidad de arena, polvo, barro y agua. En motocicleta, ATV o UTV.

Puede elegir pastillas de carreras para competir a todos los niveles o bien pastillas alternativas para salidas de ocio. Nuestra gama cubre todas las marcas y modelos todoterreno, así como las aplicaciones delantera y trasera.

La mayoría de las pastillas de freno tienen la homologación ECE R90.

Puede elegir entre:

- // UPGRADE & RACING – RSI / PSI
- // CLUB, TRAILS & LEISURE – SI / CS / ATS

Para acertar con las pastillas de su motocicleta, siga nuestras recomendaciones.



GO AHEAD



# RACING / CLUB, TRAILS & LEISURE



## RSI - SINTER

FRONT / DELANTE • REAR / POSTERIOR



- // Performance upgrade choice of MX GP World Championship MX GP and MX2 teams and riders
- // Sintered compound formulated for high thermal stability, powerful and predictable fade-free performance
- // Compatible with OE standard brake rotors and specially designed racing rotors



- // Alternativa con mejora de prestaciones elegida por equipos y pilotos del Campeonato del Mundo de MX GP y MX2
- // Compuesto sinterizado formulado para ofrecer alta estabilidad térmica, potencia y resultados predecibles sin desgaste
- // Compatible con discos de frenos estándar originales y discos para frenos de carreras con diseño especial



## SI - SINTER

FRONT / DELANTE • REAR / POSTERIOR



- // The upgrade choice for muddy, wet or sandy conditions
- // Sintered compound formulated for extended service intervals, high performance and easy modulation
- // Class-leading smooth performance developed in racing under severe conditions



- // La alternativa moderna para lugares con mucho barro, humedad o arena
- // Compuesto sinterizado formulado para ofrecer largos periodos de vida útil, alto rendimiento y fácil modulación
- // Rendimiento estable de primer nivel desarrollado en carrera en condiciones rigurosas



Brake performance diagrams to be compared individually within OFF ROAD compounds only.



Diagramas de potencia de freno para comparar de forma individual los compuestos de OFF ROAD exclusivamente.





OFF ROAD & ATV BRAKE PADS



## CLUB, TRAILS & LEISURE



### PSI - EVO SINTER

FRONT / DELANTE • REAR / POSTERIOR



- // Ultimate upgrade compound for ATVs and UTVs
- // State-of-the-art conductive sintered EVO compound formulated for strong initial bite to give instant brake feeling, easy modulation and powerful in-stop performance
- // Fade free, consistent and reliable performance under extreme conditions and throughout brake pad lifetime
- // NRS Technology secures a mechanical and indestructible bonding of the compound
- // Full-range availability completed Q1 2021



- // Compuesto de recambio original y mejorado para ATV y UTVs
- // Compuesto EVO con sinterizado conductivo de vanguardia, formulado para lograr una mordida inicial enérgica con sensación inmediata de frenado, fácil modulación y altas prestaciones en las paradas
- // Resistente al desgaste con rendimiento constante y fiable en condiciones de conducción extremas y durante toda la vida útil de la pastilla de freno
- // Tecnología NRS que garantiza una adherencia mecánica e indestructible del compuesto
- // Disponibilidad de la gama completa en el primer trimestre de 2021

Brake performance diagrams to be compared individually within OFF ROAD compounds only.

Diagramas de potencia de freno para comparar de forma individual los compuestos de OFF ROAD exclusivamente.



### ATS - SINTER

FRONT / DELANTE • REAR / POSTERIOR



- // OE replacement compound for combination with plain steel brake rotors
- // Sintered compound compatible with OE standard plain steel brake rotors as used with older Arctic Cat & Polaris ATV models



- // Compuesto de recambio original para combinar con discos de freno de acero normales
- // Compuesto sinterizado compatible con modelos originales de discos de freno de acero normales, como los que se emplean en los modelos ATV Arctic Cat y Polaris ATV



### CS - CARBON

FRONT / DELANTE • REAR / POSTERIOR



- // Affordable replacement choice for hobby motocross and competition
- // Carbon compound offers smooth, quiet and non-grabbing performance
- // NUCAP NRS technology secures a mechanical and indestructible bonding of the compound



- // Alternativa de recambio económica para competición y aficionados al motocross
- // Compuesto de carbono con funcionamiento suave, silencioso y sin agarrotamiento
- // Tecnología NUCAP NRS que garantiza una adherencia mecánica e indestructible del compuesto

**BRAKE SHOES WITH SPRINGS**

**ZAPATAS DE FRENO CON MUELLES**



Asbestos-free brake lining for superior performance and durability under all weather conditions. High grade alloy for superior strength. Surface treated against corrosion. Brake shoe springs made of high quality spring wire steel according to DIN 17223 specifications for max. flexibility.



Guarnición de freno sin amianto que ofrece un resultado y una durabilidad superiores en cualquier clima Aleación de aluminio de alta calidad con resistencia superior Superficie con tratamiento anticorrosión Muelles realizados con alambre de acero de alta calidad conforme con las especificaciones DIN 17223 para una flexibilidad máxima.



**BRAKE PINS**

## STAINLESS BRAKE PINS

## TORNILLOS DE FRENO INOXIDABLES

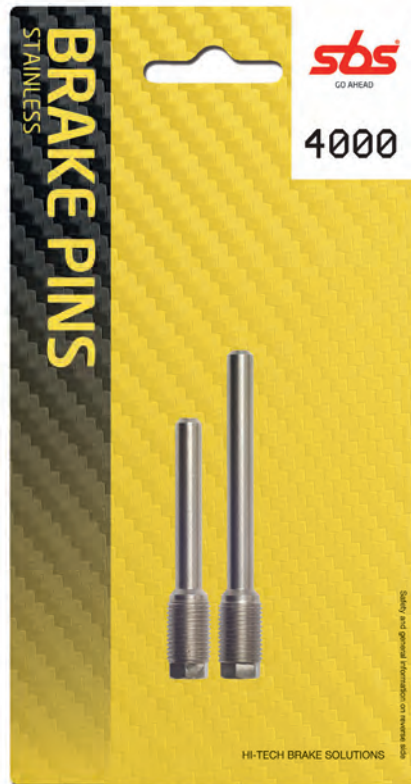

The SBS stainless brake pin range covers the most common MX and Enduro bikes from the early 1990s until today.

The range comprises 5 complete sets, front and rear together, but are also available as single packs with only front or rear to the respective model. Brake pad pins get wear grooves after a while so it is recommended to replace them regularly in order to prevent stiction and poor performance.

- // Made of high quality stainless steel 304
- // 8 mm hex head for quick and easy change of brake pad (excl. ref 4003)
- // Corrosion resistant
- // Smooth sliding between pin and brake pads



La serie de tornillos de freno inoxidable de SBS cubre las gamas de motocicletas MX y Enduro más comunes que aparecieron en la década de 1990 y que siguen existiendo en la actualidad.

La gama incluye 5 juegos completos de tornillos delanteros y traseros, pero también hay disponibles paquetes individuales (solo con tornillos delanteros o solo con traseros) específicos para cada modelo. Los tornillos de las zapatas de los frenos presentan grietas de desgaste después de un tiempo, por lo que se recomienda sustituirlos de forma periódica para evitar problemas de fricción estática y escaso rendimiento.

- // Realizados en acero inoxidable 304 de alta calidad
- // Cabeza hexagonal de 8 mm para un cambio rápido y fácil de la zapata del freno (excl. ref 4003)
- // Anticorrosión
- // Acoplamiento suave entre tornillos y zapatas de freno



## ACCESSORIES

## ACCESORIOS



### BRAKE SYSTEM BLEEDER

Motorcycle brake system bleeder which allows quick, safe and clean exchange of brake fluid. Access to min. 6 bar air pressure is necessary. The bleeder is made of the best and most durable brake fluid resistant materials which means that it handles the highly corrosive brake fluid in a closed circuit. A special safety and "tip-over" valve, prevents the fluid to leak out when the container is full.

- // Built-in "tip-over" valve
- // Turnable line fitting
- // Additional 2-nipple line included
- // Manual in 12 languages

Part number 5809839100  
EPDM rubber units  
Art. number 5809939100 (10 pcs.)



### PURGADOR DE FRENOS

Purgador del sistema de frenos de la motocicleta que permite cambiar el líquido de freno de forma rápida, limpia y segura. Se requiere una presión del aire mínima de 6 bar. El purgador de frenos está realizado con los materiales mejores y más resistentes al líquido de freno: el líquido, que es muy corrosivo, se mantiene en un circuito cerrado. Una válvula de seguridad especial y "antivuelco" impide la pulverización del líquido cuando el recipiente está lleno.

- // Válvula "antivuelco" incorporada
- // Llave giratoria
- // Conducto adicional de doble boquilla incluido
- // Manual en 12 idiomas

N.º de pieza 5809839100  
Unidades de caucho EPDM  
N.º art. 5809939100 (10 uds.)



### ANTI-NOISE SHIMS

- // Vibration/noise resistant
- // Temperature transfer resistant
- // Piston protective
- // Do not use for racing

Part number 9500



### CUÑAS DE PASTILLAS DE FRENO

- // Resistente a vibraciones/ruidos
- // Resistente a la transferencia del calor
- // Ideal para proteger el pistón
- // Mejor sensación de frenado
- // No utilizar en carreras

N.º de pieza 9500 (uds.)



MERCHANDISE

**MERCHANDISE**

**ARTÍCULOS PROMOCIONALES**



**T-SHIRT GO AHEAD**

Art. no.	Size
6829915100	M
6839915100	L
6849915100	XL
6859915100	XXL



**POLO-SHIRT**

Art. no.	Size
6829969100	M
6839969100	L
6849969100	XL



**HOODIE**

Art. no.	Size
6819916100	S
6829916100	M
6839916100	L
6849916100	XL
6859916100	XXL
6869916100	XXXL



**JACKET - DOWN&FEATHER**

Art. no.	Size
6829841100	M
6839841100	L
6849841100	XL



**BEANIE - 10 pcs**

Art. no.	Size
6829918100	M
6839918100	L



**SOCKS**

Art. no.	Size
6819801100	39-42
6829801100	43-45



**FLUID CAP  
- 10 pcs**

Art. no.
6809800100



**GLOVES**

Art. no.	Size
6829812100	M
6839812100	L
6849812100	XL



**EARPLUGS**

Art. no.
6809815100



MERCHANDISE



MERCHANDISE

ARTÍCULOS PROMOCIONALES



SWEETS – 1 kg.

Art. no.  
6809842100



UMBRELLA – ø130 cm

Art. no.  
6809835100



POWERBANK –  
KEYHOLDER

Art. no.  
6809807100



PERSONAL NOTEBOOK

Art. no.  
6809816100



PENS – 50 pcs

Art. no.  
6809804100



FLAG

Art. no.  
6809875100  
  
150 x 200 cm



RE-USABLE WATER BOTTLE – 50 cl

Art. no.  
6809975100



NRS BRAKE PAD DISPLAY – 2 pcs

Art. no.  
6809905100



Sticker

Art. no.  
6809702100 – ø34 mm  
6809701100 – ø80 mm



Auth. Dealership Sticker

Art. no.  
6809700100 – ø240 mm



Sticker Racing Supertack

Art. no.  
6809703100



Sticker Racing Supertack

Art. no.  
6809704100



BANNER

Art. no.  
6809824100 – 3 logos – 4 x 0.8 m  
6809825100 – 6 logos – 8 x 0.8 m



BUNTING 10 m

Art. no.  
6809826100

## SALES & POS MATERIAL

### DISPLAYS



SBS offers practical and robust sales displays for POS promotion of SBS products. Choose between:



SBS ofrece expositores prácticos y resistentes para exhibir el material de promoción de los productos SBS en el punto de venta. Puede elegir entre:



**DISPLAY FOR WALL OR DESK MOUNTING**  
Art. no. 6809899100

Wall mountings and instruction 6 screws with raw plugs 12 hooks, 20 ref. cards. Width 57.2 cm, height 86.5 cm.



**10 HOOKS FOR DISPLAY RACK**  
Art. no. 6809833100



**10 REF. CARDS FOR DISPLAY RACK**  
Art. no. 6809834100



**DISPLAY FOR WALL MOUNTING**  
Art. no. 6809832100

Complete with: Wall mountings and instruction 6 screws with raw plugs 36 hooks, 40 ref. cards. Width 40 cm, depth 30 cm, height 229 cm.



POSTER MATERIAL

## PRINT MATERIALS

## CHAMPION POSTERS 2021



Booklet:  
**MOTORCYCLE AND SCOOTER BRAKE PADS**  
English: Art. no. 6809911100

Other languages on request.



Flyer:  
**DYNAMIC RACING CONCEPT**  
English: Art. no. 6809979100

Other languages on request.



Flyer:  
**BRAKE DISCS**  
English: Art. no. 6809830100

Other languages on request.

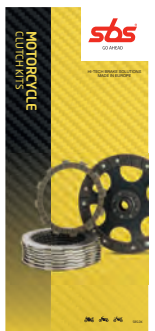

Flyer:  
**CLUTCH KITS**  
English: Art. no. 6809978100

Other languages on request.



**WORLD CHAMPION  
SUPERSPORT 300**  
50 x 70 cm

Art. no.  
6809726100



**WORLD CHAMPION  
SUPERSPORT 600**  
50 x 70 cm

Art. no.  
6809727100



**BRITISH SUPERBIKE  
CHAMPION**  
50 x 70 cm

Art. no.  
6809728100



**GERMAN SUPERBIKE  
CHAMPION**  
50 x 70 cm

Art. no.  
6809729100





POSTER MATERIAL

POSTER MATERIAL



THE PERFECT CHOICE FOR OFF-ROAD  
50 x 70 cm

Art. NO.  
6809711100



OFF-ROAD COMPOUND RSI  
50 x 70 cm

Art. no.  
6809713100



ATV/UTV COMPOUND PSI  
50 x 70 cm

Art. no.  
6809714100



DYNAMIC RACING CONCEPT  
50 x 70 cm

Art. no.  
6809712100



ANY MARKE, MODEL, YEAR  
50 x 70 cm

Art. no.  
6809715100



CHOOSE YOUR BRAKE PADS  
70 x 100 cm

Art. no.  
6809716100

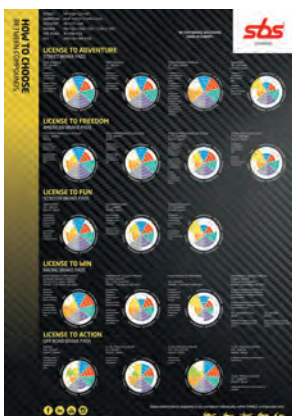

CHOOSE BETWEEN COMPOUNDS  
70 x 100 cm

Art. no.  
6809717100

## MODEL LOOK-UP WIDGET



USE THE MODEL LOOK-UP WIDGET AT [WWW.SBSBRAKES.COM](http://WWW.SBSBRAKES.COM)

Go online and find the best brake products for exactly your bike.

- // Go to [www.sbsbrakes.com](http://www.sbsbrakes.com)
- // Select your specific bike model, year and CCM (in random order)
- // The brake pads, brake rotors and clutch kits that match your bike will be listed (recommended and optional)

Go Ahead!

## WIDGET DE CONSULTA DE MODELOS



UTILICE EL WIDGET DE CONSULTA DE MODELOS QUE SE ENCUENTRA EN [WWW.SBSBRAKES.COM](http://WWW.SBSBRAKES.COM)

Conéctese y encuentre los mejores productos de frenado para su moto.

- // Vaya a [www.sbsbrakes.com](http://www.sbsbrakes.com)
- // Seleccione el modelo de moto concreto, el año y la cilindrada (en orden aleatorio)
- // Aparecerá una lista con las pastillas de freno, los discos de freno y los kits de embrague que puede utilizar su moto (recomendados y optativos)

¡Adelante!

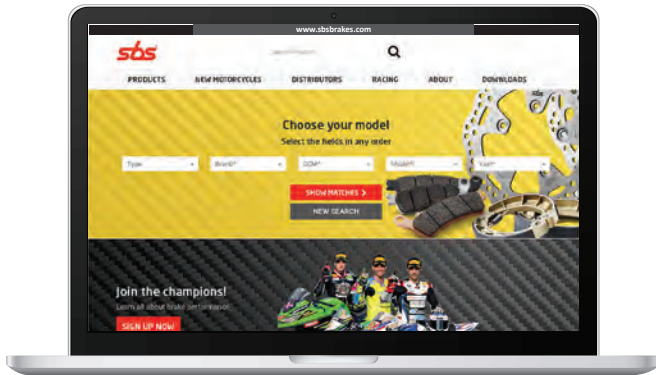

**ANY MAKE.  
ANY MODEL.  
ANY YEAR.**

Go online and find exactly what you need.

Use the **Model Look-up widget** at [www.sbsbrakes.com](http://www.sbsbrakes.com)

## COMPOUND SELECTOR WIDGET



USE THE COMPOUND SELECTOR AT [WWW.SBSBRAKES.COM](http://WWW.SBSBRAKES.COM)

Go online and find the ideal brake compound for your bike type and need.

- // Go to [www.sbsbrakes.com](http://www.sbsbrakes.com)
- // Select your specific bike type, touring conditions and size
- // The right compound type that matches your bike type and need will be listed for front and rear

Go Ahead!

## WIDGET DEL SELECTOR DE COMPUESTO



UTILICE EL WIDGET DEL SELECTOR DE COMPUESTO QUE SE ENCUENTRA EN [WWW.SBSBRAKES.COM](http://WWW.SBSBRAKES.COM)

Conéctese y encuentre el compuesto de freno ideal para su tipo de motocicleta y sus necesidades.

- // Vaya a [www.sbsbrakes.com](http://www.sbsbrakes.com)
- // Seleccione el tipo de motocicleta, las condiciones de uso y el tamaño concretos
- // Se indicará el tipo de compuesto adecuado al tipo de motocicleta y a sus necesidades para la parte delantera y la parte trasera

¡Adelante!

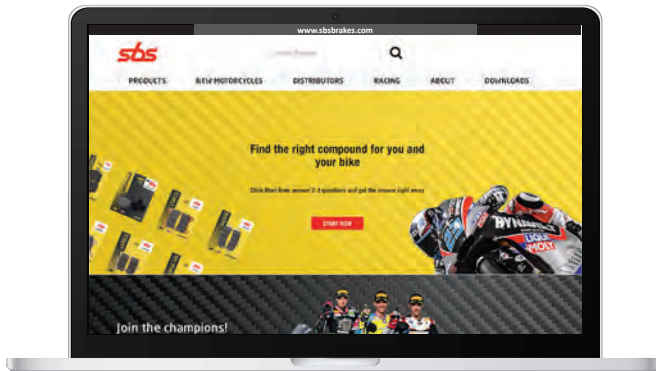

**GET THE  
BRAKE FEEL  
YOU WANT!**

Go online and find the right compound for you and your bike.

Use the **Compound Selector widget** at [www.sbsbrakes.com](http://www.sbsbrakes.com)



**Emil Senf Jakobsen**

Category Manager SBS

**sbs**<sup>®</sup>

GO AHEAD

**I KNOW  
WHAT YOU  
WANT!**

**MOTORCYCLE  
SCOOTER  
DIRT BIKE  
ATV/UTV**



@sbsbrakes | sbsbrakes.com | #GoAhead

HI-TECH BRAKE SOLUTIONS  
MADE IN EUROPE

**RECOMMENDED**1xx - 2xx = Scooter Pads  
5xx - 9xx = Street, Off Road & Racing Pads  
2xxx = Brake Shoes

	25 Silver Fox	00 - 05	111 HF	2028	
	50 Cat	01 - 08	111 HF		
	50 Cosy	01 - 08	111 HF		
	50 Fox	00 - 09	111 HF	2028	
	50 Fox Plus	01 - 09	111 HF		
	50 Jet	96 - 99	111 HF	2028	
	50 Panther	01 - 09	102 HF		
	50 Pista, Pista Twin Light	96 - 99	111 HF	2028	
	50 Silver Fox	00 - 05	111 HF	2028	
	50 Silver Fox	06 - 09	102 HF	2028	
	50 Super Sonic	00 - 05	102 HF*		
	50 Thunderbike	97 - 09	102 HF		
RS	50 Super Sonic	06 - 08	102 HF	102 HF	
RT	50 Road Tracer	02 - 06	111 HF		
	70 Fox Plus	01 - 05	111 HF		
	70 Pista, Pista Twin Light	01 - 05	111 HF		
	80 Cosy	01 - 06	111 HF		
RT	90 Road Tracer	02 - 06	111 HF		
	100 Cat	01 - 08	111 HF		
	100 Jet	96 - 99	111 HF	2028	
	100 Panther	01 - 06	102 HF		
	100 Silver Fox	01 - 05	111 HF		
	100 Silver Fox	06 - 06	102 HF	2028	
	100 Super Sonic	01 - 05	102 HF*		
	100 Thunderbike	01 - 04	102 HF*	102 HF	
RT	100 Road Tracer	02 - 06	111 HF		
	125 Cat	01 - 04	111 CT		
	125 Super Sonic	01 - 05	102 CT*		
	125 Thunderbike	01 - 04	102 CT*	102 CT	
	150 ATV	05 - 07	544 SI*	544 SI	
	150 Interceptor	05 - 07	544 SI*	544 SI	
	300 ATV	05 - 11	544 SI*	544 SI	
	300 Cross X Over	07 - 11	810 SI*		
	300 Cross X Road	07 - 11	810 SI*		
ATV	300 Sport	07 - 13	810 SI*	848 SI	
	320 S	07 - 13	810 SI*		
	320 U	07 - 13	810 SI*		

**APRILIA**

	50 Mini RX	04 - 04	803 RSI		
	50 Sport City One	08 - 12	177 HF		
RS-4	50	12 - 19	189 MS	101 HF	
RS-4	50 Replica	16 - 17	189 MS	101 HF	
SR	50 Ditech	01 - 06	123 HF	152 HF	
SR	50 Motard	18 - 22	237 HF		
SR	50 Racing	00 - 04	123 HF	152 HF	
SR	50 Replica	94 - 96	117 HF	2012	
SR	50 Replica (Liquid Cooled)	96 - 96	123 HF	2012	
SR	50 Stealth, Racing	97 - 00	123 HF	123 HF	
SR	50 Street	05 - 12	123 HF	152 HF	
SR	50 WWW, Netscaper	97 - 99	149 HF	2012	
SX	50 Ltd.	07 - 15	197 CT	101 CT	
	125 Tuono ABS	17 - 19	821 HS	544 HF	
RS	125 GP	17 - 19	821 HS	544 HF	
RS-4	125 (AJP cal.)	11 - 19	821 HS	585 HF	
RS-4	125 (J.Juan cal.)	11 - 19	566 HS	544 HF	
RS-4	125 Replica, ABS	16 - 19	821 HS	544 HF	
SR	125	99 - 03	153 CT	2205	
SR	125 Max	12 - 17	177 CT	177 CT	
SR	125 Sport City One	12 - 12	177 CT		
SX	125	08 - 13	671 HF	651 HF	
SR	150	00 - 03	153 CT	2205	
	200 Sportcity	04 - 08	108 CT	152 CT	
RS	250 Pista	04 - 04	706 HF*	519 HF	
SR	300 Max	12 - 19	177 MS	177 MS	
MXV	450	09 - 13	694 RSI	790 RSI	
RXV	450	06 - 13	694 SI	790 SI	
SXV	450	06 - 13	842 RSI	790 RSI	

**APRILIA**

SXV	450 Van den Bosch Rep.	08 - 10	695 RST	790 RSI
RXV	550	06 - 13	694 SI	790 SI
SXV	550	06 - 13	842 RSI	790 RSI
SXV	550 Van den Bosch Rep.	08 - 10	695 RST	790 RSI
	650 Pegaso	92 - 94	681 HF	651 HF
	650 Pegaso	95 - 00	674 HS	692 HF
	650 Pegaso Strada	05 - 09	706 HS	675 LS
	660 Tuareg	22 - 22	674 SP*	675 LS
	660 Tuono Factory	22 - 22	900 SP*	730 LS
RS	660	20 - 22	900 SP*	730 LS
RS	660 Trofeo	22 - 22	900 SP*	730 LS
	750 Dorsoduro Factory	12 - 13	706 HS*	675 LS
SL	750 Shiver GT, ABS	09 - 12	844 HS*	675 LS
SL	750 Shiver, ABS	07 - 18	844 HS*	675 LS
SMV	750 Dorsoduro	08 - 08	706 HS*	675 LS
SMV	750 Dorsoduro	09 - 18	844 HS*	675 LS
NA	850 Mana	07 - 07	844 HS*	675 LS
NA	850 Mana GT, ABS	09 - 13	844 HS*	588 HF
NA	850 Mana GT, ABS (Parking Brake)	09 - 13		879 HF
NA	850 Mana, ABS	08 - 11	844 HS*	588 HF
	1000 Blue Marlin	02 - 02	706 HS*	730 LS
ETV	1000 Caponord	01 - 08	674 HS*	730 LS
ETV	1000 Caponord Rally Raid	04 - 08	674 HS*	730 LS
RST	1000 Futura	01 - 03	706 HS*	671 LS
RSV	1000	97 - 01	706 HS*	730 LS
RSV	1000	02 - 03	762 HS*	730 LS
RSV	1000 Factory Pista	04 - 04	762 HS*	730 LS
RSV	1000 Falco SL, R	00 - 04	706 HS*	730 LS
RSV	1000 Nera	04 - 04	762 HS*	730 LS
RSV	1000 R	00 - 00	706 HS*	730 LS
RSV	1000 R	01 - 07	762 HS*	730 LS
RSV	1000 R Factory	04 - 08	762 HS*	730 LS
RSV	1000 SP	00 - 00	706 HS*	730 LS
RSV	1000 Tuono Fighter	03 - 05	706 HS*	730 LS
RSV	1000 Tuono R	03 - 03	762 HS*	730 LS
RSV	1000 Tuono R Factory, ABS	06 - 12	762 HS*	730 LS
RSV	1000 Tuono R, ABS	04 - 12	706 HS*	730 LS
RSV	1000 Tuono V4 R	11 - 13	706 HS*	730 LS
RSV	1000 Tuono V4 R	14 - 14	900 HS*	730 LS
RSV4	1000 , ABS	09 - 13	841 SP*	730 LS
RSV4-R	1000 , ABS APRC	10 - 10	841 SP*	730 LS
RSV4-RF	1000	15 - 20	901 SP*	730 LS
RSV4-RR	1000	15 - 20	901 SP*	730 LS
RSV	1100 Tuono V4	15 - 15	900 HS*	730 LS
RSV	1100 Tuono V4 Factory	15 - 16	900 HS*	730 LS
RSV	1100 Tuono V4 Factory	17 - 18	901 HS*	730 LS
RSV	1100 Tuono V4 RR	15 - 16	900 HS*	730 LS
RSV	1100 Tuono V4 RR	17 - 19	901 HS*	730 LS
RSV4	1100 Factory	19 - 20	841 SP*	730 LS
	1200 Caponord	13 - 19	900 SP*	675 LS
	1200 Caponord Rally	15 - 19	900 SP*	675 LS
	1200 Caponord Travel Pack	16 - 19	900 SP*	675 LS
	1200 Dorsoduro, ABS	11 - 14	706 HS*	675 LS

**ARCTIC CAT**

	50 2WD	04 - 06	2048*	
	50 DVX	06 - 08	2048*	638 SI
	90 2WD	02 - 04	2048*	
	90 DVX	06 - 14	2048*	638 SI
	250 2x4	05 - 06	822 ATS*	822 ATS
	250 2x4 (Man. Hand Brake)	99 - 04		827 ATS
	250 2x4/4x4	99 - 04	758 ATS*	758 ATS
	250 4x4 (Man. Hand Brake)	00 - 04		827 ATS
	250 DVX	06 - 09	810 SI*	775 SI
	300 2x4	10 - 13	822 ATS*	822 ATS
	300 2x4 (Man. Hand Brake)	98 - 04		827 ATS
	300 2x4/4x4	98 - 04	758 ATS*	758 ATS

\* = 2 sets required / 2 jeux pour l'Avant.



**RECOMMENDED**

1xx - 2xx = Scooter Pads  
 5xx - 9xx = Street, Off Road & Racing Pads  
 2xxx = Brake Shoes



ARCTIC CAT			
300 4x4	05 - 05	822 ATS*	822 ATS
300 4x4 (Man. Hand Brake)	98 - 05		827 ATS
300 DVX	09 - 16	810 SI*	775 SI
375 2x4/4x4	02 - 02	758 ATS*	758 ATS
375 2x4/4x4 (Man. Hand Brake)	02 - 02		827 ATS
400 2x4 (Man. Hand Brake)	98 - 02		827 ATS
400 2x4/4x4	98 - 04	758 ATS*	758 ATS
400 2x4/4x4 (FIS)	02 - 04	758 ATS*	758 ATS
400 2x4/4x4 (FIS)	05 - 07	822 ATS*	822 ATS
400 2x4/4x4 (FIS) Aut. (Man. Hand Brake)	03 - 04		827 ATS
400 2x4/4x4 (FIS) (Man. Hand Brake)	02 - 04		827 ATS
400 2x4/4x4 (FIS) (Man. Hand Brake)	05 - 08		758 ATS
400 4x4 (Man. Hand Brake)	98 - 04		827 ATS
400 DVX	04 - 08	592 SI*	649 SI
400 TBX 4x4	04 - 04	758 ATS*	758 ATS
400 TBX 4x4 (Man. Hand Brake)	04 - 04		827 ATS
TRV 400	09 - 13	822 ATS*	822 ATS
440 Bear Cat	96 - 97		758 ATS
450 H1	10 - 10	822 ATS*	822 ATS
XC 450	11 - 14	822 ATS*	822 ATS
454 Arctic Cat 4x4	98 - 98	758 ATS*	758 ATS
454 Bear Cat 2x4/4x4	96 - 98	758 ATS*	758 ATS
454 Bear Cat 2x4/4x4 (Man. Hand Brake)	98 - 98		827 ATS
500 2x4 (FIS) (Man. Hand Brake)	02 - 02		827 ATS
500 2x4 (Man. Hand Brake)	02 - 02		827 ATS
500 2x4/4x4	98 - 04	758 ATS*	758 ATS
500 2x4/4x4 (FIS)	02 - 04	758 ATS*	758 ATS
500 2x4/4x4 (FIS)	05 - 09	822 ATS*	822 ATS
500 4x4 (FIS) Aut. (Man. Hand Brake)	02 - 03		827 ATS
500 4x4 (FIS) (Man. Hand Brake)	02 - 03		827 ATS
500 4x4 (Man. Hand Brake)	98 - 02		827 ATS
500 TBX 4x4	02 - 04	758 ATS*	758 ATS
500 TBX 4x4	05 - 06	822 ATS*	822 ATS
500 TBX 4x4 (Man. Hand Brake)	03 - 04		827 ATS
500 TBX 4x4 Aut. (Man. Hand Brake)	02 - 02		827 ATS
500 TRV 4x4	03 - 04	758 ATS*	758 ATS
500 TRV 4x4	05 - 06	822 ATS*	822 ATS
500 TRV 4x4 (Man. Hand Brake)	03 - 04		827 ATS
550 H1	09 - 13	822 ATS*	822 ATS
550 LTD	09 - 12	822 ATS*	822 ATS
550 Prowler	09 - 14	822 ATS*	822 ATS
TRV 550	09 - 14	822 ATS*	822 ATS
650 H1 4x4 Aut.	05 - 11	822 ATS*	822 ATS
650 Prowler	06 - 08	822 ATS*	822 ATS
650 V2 4x4 Aut.	05 - 06	822 ATS*	822 ATS
650 V2 4x4 Aut. LE	05 - 06	822 ATS*	822 ATS
700 Diesel	06 - 14	822 ATS*	822 ATS
700 H1	09 - 10	822 ATS*	822 ATS
700 Prowler	08 - 08	822 ATS*	822 ATS
700 Wildcat Sport	15 - 18	946 ATS*	822 ATS
700 Wildcat Sport LTD.	16 - 18	946 ATS*	822 ATS
700 Wildcat Sport LTD. EPS	17 - 18	946 ATS*	822 ATS
700 Wildcat Sport XT	15 - 18	946 ATS*	822 ATS
700 Wildcat Sport XT EPS	16 - 18	946 ATS*	822 ATS
TBX 700	12 - 14	822 ATS*	822 ATS
TRV 700	09 - 12	822 ATS*	822 ATS



**RECOMMENDED**

1xx - 2xx = Scooter Pads  
 5xx - 9xx = Street, Off Road & Racing Pads  
 2xxx = Brake Shoes



ARCTIC CAT			
1000 Prowler	09 - 09	822 ATS*	822 ATS
1000 Thundercat	09 - 14	822 ATS*	822 ATS
1000 Wildcat 4X	16 - 18	912 ATS*	822 ATS
1000 Wildcat X	16 - 18	912 ATS*	822 ATS
1000 Wildcat X Ltd.	17 - 18	912 ATS*	822 ATS
1000 Wildcat X SE	17 - 18	912 ATS*	822 ATS
TRV 1000	09 - 14	822 ATS*	822 ATS
<b>ARMSTRONG</b>			
MX 500	86 - 86	519 SI	
MX 600	86 - 86	519 SI	
<b>BENELLI</b>			
TNT 125	17 - 17	558 HF	
TNT 125	18 - 19		915 HF
TNT 135	18 - 19		915 HF
BN 302 R	17 - 19	933 HS*	832 LS
BN 302 S	18 - 19	933 HS*	832 LS
350 Zenzero	12 - 15	163 CT	101 CT
BX 449 Cross	07 - 09	671 RSI	675 RSI
500 C	19 - 19	762 HS*	730 LS
500 Leoncino	16 - 17	706 HS*	730 LS
TRK 502	16 - 17	706 HS*	730 LS
TRK 502	18 - 19	762 HS*	832 LS
TRK 502 X	17 - 21	983 HS*	832 LS
BX 505 Enduro	08 - 08	671 SI	675 SI
BN 600	12 - 13	706 HS*	730 LS
BN 600	14 - 17	762 HS*	730 LS
BN 600 GT	14 - 15	762 HS*	730 LS
T 600 Tornado Naked	20 - 20	762 HS*	730 LS
654 Sport	83 - 83	519 HF*	519 HF
750 Sei	75 - 78	506 HF*	
752 S	20 - 20	900 HS*	730 LS
756 Cue	07 - 09	762 HS*	730 LS
756 Cue	10 - 12	706 HS*	730 LS
800 Leoncino	20 - 20	900 HS*	730 LS
899 Trek	07 - 12	706 HS*	730 LS
TnT 899	07 - 15	706 HS*	730 LS
TnT 899 Century Racer	11 - 11	762 HS*	730 LS
900 Sei	81 - 83	554 HF*	
900 Sei	84 - 84	506 HF*	506 HF
900 Tornado 3	00 - 06	706 HS*	519 LS
900 Tornado TRE	03 - 06	762 HS*	730 LS
900 Tornado TRE RS	04 - 06	762 HS*	730 LS
TnT 1100	04 - 04	706 HS*	519 LS
TnT 1130	05 - 14	706 HS*	730 LS
TnT 1130 Cafe Racer	05 - 13	762 HS*	730 LS
TnT 1130 Century Racer	11 - 12	762 HS*	730 LS
TnT 1130 Officine	07 - 07	762 HS*	730 LS
TnT 1130 R	17 - 17	841 HS*	730 LS
TnT 1130 Sport	05 - 08	762 HS*	730 LS
TnT 1130 Titanium	05 - 08	762 HS*	730 LS
TnT 1130 Trek	06 - 12	706 SP*	730 LS
TnT 1130 Trek Amazonas	07 - 15	706 SP*	730 LS
<b>BETA</b>			
50 AJP Caliper incl. pin/spring	90 - 19	188 HF	
50 ProRace 12/10	04 - 04	803 RSI	803 RSI
50 Rev	00 - 09	559 HF	559 HF
ST 50	97 - 97	559 HF	559 HF
80 EVO	09 - 10	802 RSI	
80 EVO Junior	10 - 11	559 HF	559 HF
80 Rev	00 - 07	559 HF	559 HF
80 Rev	08 - 10	802 RSI	896 RSI
125 EVO	09 - 14	802 RSI	895 RSI
125 Rev 3	00 - 05	802 RSI	802 RSI
125 Rev 3	06 - 08	802 RSI	896 RSI

\* = 2 sets required / 2 jeux pour l'Avant.

Full compound selection, see under "Brake pad 1:1 Drawings" / Sélection complète de composés, voir "1:1 Schémas Plaquettes de frein".

**RECOMMENDED**1xx - 2xx = Scooter Pads  
5xx - 9xx = Street, Off Road & Racing Pads  
2xxx = Brake Shoes

<b>BETA</b>					
ALP	125	90 - 90	595 HF	607 HF	
ALP	125	99 - 09	559 RSI	559 RSI	
ALP	125 4-stroke	00 - 05	559 RSI	559 RSI	
ALP	125 4-stroke	06 - 09	774 HF	861 HF	
RR	125	18 - 19	694 SI	790 SI	
SR	125 34	89 - 89	559 HF	636 HF	
TR	125 32,33	86 - 87	595 HF		
TR	125 34	88 - 88	595 HF	607 HF	
TR	125 34	92 - 92	672 HF	636 HF	
TR	125 34,35	89 - 90	559 RSI	559 RSI	
TR	125 36	92 - 92	672 HF	636 HF	
TRIAL	125	97 - 97	559 RSI	636 HF	
R	150	10 - 13	814 HF		
	200 EVO	09 - 14	802 RSI	895 RSI	
	200 Rev 3	06 - 08	802 RSI	896 RSI	
ALP	200 4-stroke	00 - 05	559 RSI	559 RSI	
ALP	200 4-stroke	06 - 20	774 HF	861 HF	
	240 Super Trial	92 - 92	559 RSI	636 HF	
ALP	240	92 - 92	559 RSI	636 HF	
ALP	240	96 - 96	559 RSI	519 RSI	
TR	240 33	86 - 88	595 HF		
	250 4-T Rev 3	07 - 11	802 RSI	896 RSI	
	250 EVO (2-T / 4-T)	09 - 14	802 RSI	895 RSI	
	250 Rev 3	00 - 04	802 RSI	802 RSI	
	250 Rev 3	05 - 09	802 RSI	896 RSI	
	250 Techno	96 - 96	559 RSI	559 RSI	
	250 Zero	91 - 91	559 RSI	636 HF	
ALP	250	92 - 92	559 RSI	636 HF	
ALP	250	97 - 03	559 RSI	559 RSI	
RR	250	05 - 09	694 SI	790 SI	
	260 Synt	92 - 92	595 HF	636 HF	
	260 Zero	91 - 91	559 RSI	636 HF	
ALP	260	96 - 96	559 RSI	519 RSI	
TR	260 34	86 - 88	595 HF	607 HF	
TR	260 34,35,ZERO	89 - 92	559 RSI	636 HF	
	270 Rev 3	00 - 04	802 RSI	802 RSI	
	270 Rev 3	05 - 08	802 RSI	896 RSI	
	290 EVO	09 - 13	802 RSI	895 RSI	
	300 Crosstrainer	15 - 15	694 SI	790 SI	
	300 EVO	09 - 15	802 RSI	895 RSI	
RR	300	13 - 19	694 SI	790 SI	
	350 4.0 Motard	04 - 06	566 RSI	574 RSI	
ALP	350 4.0	04 - 05	774 HF	574 RSI	
ALP	350 4.0	06 - 18	774 HF	861 HF	
RR	350 Efi	15 - 15	694 SI	790 SI	
RR	350 Efi Racing	15 - 15	694 SI	790 SI	
RR	350 Enduro	12 - 14	694 SI	790 SI	
RR	390	15 - 19	694 SI	790 SI	
RR	400 Enduro	05 - 05	694 SI	790 SI	
RR	430	15 - 19	694 SI	790 SI	
RR	430 Racing	15 - 19	694 SI	790 SI	
RR	450 Cross Country	12 - 12	694 SI	790 SI	
RR	450 Enduro	05 - 07	694 SI	790 SI	
RR	480	15 - 19	694 SI	790 SI	
RR	480 Racing	15 - 19	694 SI	790 SI	
RR	498 Enduro	12 - 14	694 SI	790 SI	
	500 GS, RV	84 - 84	519 HF		
RR	525 Enduro	05 - 13	694 SI	790 SI	

**BIMOTA**

	all models	82 - 88	506 HF*	506 HF	
BBX	300 Enduro	12 - 12	694 SI	790 SI	
YB7	400	89 - 89	566 HF*	519 HF	
	500 Vdue	97 - 00	566 HF*	519 HF	
BBX	508 Enduro	12 - 12	694 SI	604 SI	
	600 Bellaria	91 - 91	566 HF*	519 HF	
YB9	600 SRI	97 - 97	566 HF*	519 HF	
BB1	650 Supermono	97 - 00	566 HF*	519 HF	

**RECOMMENDED**1xx - 2xx = Scooter Pads  
5xx - 9xx = Street, Off Road & Racing Pads  
2xxx = Brake Shoes

<b>BIMOTA</b>					
SB7	750	96 - 88	566 HF*	519 HF	
YB4	750	89 - 89	566 HF*	519 HF	
3D	800 Tesi	16 - 16	841 HS*	730 LS	
1D	851 Tesi	91 - 91	566 HF*	519 HF	
1D	900 Tesi	93 - 93	566 HF*	519 HF	
DB2	900	92 - 00	566 HF*	519 HF	
DB3	900 Mantra	97 - 00	566 HF*	519 HF	
DB4	900	99 - 00	706 HS*	519 LS	
1D	906 Tesi	91 - 91	566 HF*	519 HF	
	1000 Furano	92 - 93	566 HF*	519 HF	
2D	1000 Tesi	04 - 06	566 HS*	519 LS	
BB3	1000	14 - 18	901 SP*	730 LS	
DB5	1000	05 - 11	762 SP*	730 LS	
DB5	1000 S	07 - 11	762 SP*	730 LS	
DB6	1000 Delirio	07 - 09	762 HS*	730 LS	
SB3	1000 D	83 - 83	506 HF*	506 HF	
SB8	1000 R	98 - 00	706 HS*	519 LS	
SB8K	1000	06 - 06	706 HS*	519 LS	
SB8K	1000 Santamonica	07 - 09	762 HS*	519 LS	
YB11	1000	97 - 00	566 HF*	519 HF	
YB6	1000	89 - 89	566 HF*	519 HF	
YB8	1000	90 - 90	566 HF*	519 HF	
	1002 Dieci	91 - 91	566 HF*	519 HF	
DB10	1078 Bimotard	12 - 12	762 HS*	730 LS	
DB5	1078 RE	12 - 12	762 HS*	730 LS	
DB7	1098	08 - 08	762 HS*	730 LS	
DB7	1099	09 - 09	901 HS*	519 LS	
3D	1100 Tesi	07 - 11	762 SP*	730 LS	
DB6R	1100 Delirio	08 - 09	762 HS*	730 LS	
DBX	1100	13 - 18	674 HS*	671 LS	
SB6	1100	97 - 00	566 HF*	519 HF	
DB8	1198	10 - 14	901 SP*	730 LS	
	1200 Impeto	16 - 17	841 HS*	730 LS	
DB11	1200 VLX	13 - 13	901 HS*	730 LS	
DB12	1200	12 - 12	762 HS*	730 LS	
DB9	1200 Brivido	12 - 18	762 HS*	730 LS	

**BMW**

C1	125	00 - 03	176 CT	175 CT	
C1	200	02 - 04	176 CT	175 CT	
G	310 GS	17 - 22	877 HS	675 LS	
G	310 R	16 - 22	877 HS	675 LS	
C	400 GT	19 - 22	231 MS*	175 MS	
C	400 X	18 - 21	231 MS*	175 MS	
G	450 SMR	09 - 10	762 RST	791 RSI	
G	450 X	08 - 10	671 SI	791 SI	
R45	450	78 - 79	527 HF*	2139	
R45	450	80 - 85	527 HF*	2140	
C	600 Sport	12 - 15	183 MS*	183 MS	
C	600 Sport (Parking Brake)	12 - 15		209 HF	
R60	600 Series	74 - 80		2139	
R60/7	600	76 - 77	520 HF	2139	
C	650 GT	12 - 21	183 MS*	183 MS	
C	650 GT (Parking Brake)	12 - 15		209 HF	
C	650 Sport	16 - 20	183 MS*	183 MS	
F	650 , ST	94 - 00	674 HF	675 HF	
F	650 CS Scarver	02 - 06	674 HS	675 LS	
F	650 GS	08 - 12	674 HS	675 LS	
F	650 GS ABS	01 - 07	674 HF	675 HF	
F	650 GS ABS	08 - 12	674 HS	675 LS	
F	650 GS Dakar	01 - 07	674 HF	675 HF	
F	650 GS, Rallye	01 - 07	674 HF	675 HF	
F	650 ST Strada	97 - 01	674 HF	675 HF	
G	650 GS	09 - 15	674 HS	675 LS	
G	650 GS Sertao	12 - 14	674 HS	675 LS	
G	650 Xchallenge	06 - 07	674 HS	675 LS	
G	650 Xcountry	06 - 09	674 HS	675 LS	
G	650 Xmoto	06 - 07	706 HS	675 LS	

\* = 2 sets required / 2 jeux pour l'Avant.



**RECOMMENDED**

1xx - 2xx = Scooter Pads  
 5xx - 9xx = Street, Off Road & Racing Pads  
 2xxx = Brake Shoes



Model	Year	Front	Rear
BMW R65	650	78 - 79	527 HF
BMW R65	650	80 - 80	2139
BMW R65	650 GS	87 - 92	506 HF
BMW R65	650 LS	82 - 85	506 HF*
BMW R65/1	650	86 - 86	554 HF*
BMW F	700 GS	13 - 16	674 HS*
BMW R70	700 Series	74 - 80	2139
BMW F	750 GS	18 - 22	674 HS*
BMW K75	750	90 - 90	640 HS
BMW K75	750 C	85 - 88	506 HF*
BMW K75	750 RT	91 - 96	640 HS*
BMW K75	750 S, C	85 - 95	506 HF*
BMW R75	750	86 - 86	2140
BMW R75/6	750	74 - 76	520 HF
BMW R75/7	750	76 - 77	520 HF
BMW	800 Touring	87 - 87	2140
BMW F	800 GS	08 - 20	674 HS*
BMW F	800 GT	13 - 20	706 HS*
BMW F	800 R	09 - 14	706 HS*
BMW F	800 R	15 - 18	900 HS*
BMW F	800 S	06 - 10	706 HS*
BMW F	800 ST	06 - 12	706 HS*
BMW F	800 ST Touring	11 - 12	706 HS*
BMW R80	800	77 - 85	506 HF
BMW R80	800	86 - 88	554 HF
BMW R80	800 G/S P.-D.	86 - 86	506 HF
BMW R80	800 GS	81 - 87	506 HF
BMW R80	800 GS	91 - 92	506 HS
BMW R80	800 GS Mystic	91 - 95	554 HS*
BMW R80	800 GS Paris Dakar	88 - 94	554 HS
BMW R80	800 R	91 - 95	644 HS*
BMW R80	800 RT	83 - 83	506 HF*
BMW R80	800 RT	84 - 85	554 HF*
BMW R80/7	800	77 - 78	520 HF
BMW R80/7	800	79 - 81	520 HF
BMW F	850 GS	18 - 22	674 SP*
BMW F	850 GS Adventure	18 - 22	674 SP*
BMW R	850 C	99 - 01	703 HS*
BMW R	850 GS	99 - 07	703 HS*
BMW R	850 R	96 - 02	703 HS*
BMW R	850 R	03 - 07	778 HS*
BMW R	850 RT	96 - 01	703 HS*
BMW R	850 RT With Integral ABS	01 - 06	796 HS*
BMW F	900 R	20 - 22	900 SP*
BMW F	900 XR	20 - 22	900 SP*
BMW R	900 RT	05 - 13	796 HS*
BMW R90	900 S	73 - 76	520 HF*
BMW R90	900 Series	74 - 80	2139
BMW R90/6	900	73 - 76	520 HF
BMW	1000 HP4 Race	17 - 18	845 DS-1*
BMW K1	1000	89 - 89	644 HS*
BMW K100	1000 LT	87 - 87	506 HF*
BMW K100	1000 LT	92 - 94	644 HS*
BMW K100	1000 LT ABS	89 - 89	640 HS*
BMW K100	1000 RS	90 - 92	644 HS*
BMW K100	1000 RS ABS	88 - 89	640 HS*
BMW K100	1000 RS, RT	83 - 89	506 HF*
BMW M	1000 RR	21 - 22	985 SP*
BMW R100	1000	79 - 80	2139
BMW R100	1000	81 - 84	506 HF*
BMW R100	1000 all models	81 - 84	2140
BMW R100	1000 CS,RS, RT	81 - 84	506 HF*
BMW R100	1000 GS	87 - 94	554 HF
BMW R100	1000 GS Mystic	91 - 94	554 HS*
BMW R100	1000 R	91 - 95	644 HS*
BMW R100	1000 RS	76 - 80	520 HF*
BMW R100	1000 RS	93 - 95	640 HS*
BMW R100	1000 RT	91 - 95	554 HS*



**RECOMMENDED**

1xx - 2xx = Scooter Pads  
 5xx - 9xx = Street, Off Road & Racing Pads  
 2xxx = Brake Shoes



Model	Year	Front	Rear
BMW R100	1000 S	76 - 77	520 HF*
BMW R100	1000 S	78 - 80	520 HF*
BMW R100	1000 T	79 - 84	520 HF*
BMW R100/7	1000	78 - 80	520 HF
BMW S	1000 R	13 - 19	870 HS*
BMW S	1000 RR	09 - 18	870 SP*
BMW S	1000 RR (Hayes cal.)	19 - 21	960 SP*
BMW S	1000 RR (Nissin cal.)	21 - 22	985 SP*
BMW S	1000 RR HP4	12 - 14	901 SP*
BMW S	1000 XR	15 - 19	900 SP*
BMW S	1000 XR	20 - 21	960 SP*
BMW K1100	1100 LT/SE	92 - 00	644 HS*
BMW K1100	1100 RS	93 - 96	644 HS*
BMW R	1100 GS	94 - 01	703 HS*
BMW R	1100 R Cast wheels	99 - 01	703 HS*
BMW R	1100 R Spoke wheels	99 - 06	703 HS*
BMW R	1100 RT Cast wheels	95 - 01	703 HS*
BMW R	1100 RT Spoke wheels	95 - 01	703 HS*
BMW R	1100 S	99 - 00	703 HS*
BMW R	1100 S With Integral ABS	01 - 05	778 HS*
BMW R	1100 S Without Integral ABS	01 - 05	796 HS*
BMW R1100	1100 RS	93 - 93	644 HS*
BMW R1100	1100 RS	94 - 01	703 HS*
BMW R	1150 GS	00 - 01	703 HS*
BMW R	1150 GS (Brembo cal.)	02 - 05	778 HS*
BMW R	1150 GS Adventurer (Tokico cal.)	02 - 05	796 HS*
BMW R	1150 R	01 - 06	778 HS*
BMW R	1150 R Rockster	03 - 05	778 HS*
BMW R	1150 RS	01 - 04	778 HS*
BMW R	1150 RT With Integral ABS	01 - 06	796 HS*
BMW	1200 HP2 Enduro	04 - 06	674 HS*
BMW	1200 HP2 Megamoto	06 - 08	796 HS*
BMW	1200 HP2 Sport	08 - 10	901 SP*
BMW K	1200 GT (K41) With Integral ABS	02 - 05	796 HS*
BMW K	1200 GT (K44) With Integral ABS	04 - 08	796 HS*
BMW K	1200 LT	99 - 00	703 HS*
BMW K	1200 LT With Integral ABS	01 - 08	778 HS*
BMW K	1200 R	05 - 08	778 HS*
BMW K	1200 R Sport	05 - 07	778 HS*
BMW K	1200 RS	97 - 00	703 HS*
BMW K	1200 RS	01 - 05	796 HS*
BMW K	1200 S	05 - 08	796 HS*
BMW R	1200 C	98 - 02	703 HS*
BMW R	1200 C Classic	03 - 04	778 HS*
BMW R	1200 C Independent	03 - 04	778 HS*
BMW R	1200 C Montauk	02 - 04	778 HS*
BMW R	1200 CL	03 - 04	778 HS*
BMW R	1200 GS	04 - 12	796 SP*
BMW R	1200 GS	13 - 18	900 SP*
BMW R	1200 GS Adventure	08 - 13	796 HS*
BMW R	1200 GS Adventure	14 - 16	900 SP*
BMW R	1200 GS Tripple Black	11 - 16	796 SP*
BMW R	1200 Nine-T	14 - 22	900 HS*
BMW R	1200 Nine-T Pure	17 - 22	706 HS*
BMW R	1200 Nine-T Racer	17 - 20	706 HS*
BMW R	1200 Nine-T Scrambler	16 - 22	706 HS*
BMW R	1200 Nine-T Urban GS	17 - 22	706 SP*
BMW R	1200 R	07 - 14	778 HS*
BMW R	1200 R	15 - 18	900 HS*
BMW R	1200 RS	14 - 18	900 HS*
BMW R	1200 RT	06 - 13	796 HS*
BMW R	1200 RT	14 - 18	900 HS*
BMW R	1200 S	06 - 07	796 HS*
BMW R	1200 ST	06 - 07	796 HS*
BMW R	1250 GS	19 - 21	960 SP*

\* = 2 sets required / 2 jeux pour l'Avant.

Full compound selection, see under "Brake pad 1:1 Drawings" / Sélection complète de composés, voir "1:1 Schémas Plaquettes de frein".

**RECOMMENDED**1xx - 2xx = Scooter Pads  
5xx - 9xx = Street, Off Road & Racing Pads  
2xxx = Brake Shoes

			<b>RECOMMENDED</b>	
<b>BMW</b>				
R	1250 GS Adventure	19 - 21	960 SP*	674 LS
R	1250 R	19 - 22	900 HS*	674 LS
R	1250 RS	19 - 22	900 HS*	674 LS
R	1250 RT	19 - 21	960 SP*	674 LS
R	1250 RT Sport	19 - 20	960 SP*	674 LS
K	1300 GT	09 - 10	796 HS*	671 LS
K	1300 R	09 - 15	778 SP*	742 LS
K	1300 R Dynamic	11 - 15	778 SP*	742 LS
K	1300 S	09 - 15	796 HS*	742 LS
K	1600 B	17 - 22	778 HS*	674 LS
K	1600 Grand America	18 - 22	778 HS*	674 LS
K	1600 GT	11 - 22	778 HS*	674 LS
K	1600 GTL	11 - 22	778 HS*	674 LS
<b>BOMBARDIER</b>				
	50 Quest	03 - 04	2048*	2041
DS	50	02 - 06	2048*	2041
	90 Quest	03 - 04	2048*	2041
DS	90	02 - 06	2048*	2041
	200 Rally 2x4	03 - 04	544 SI*	
DS	250 Left	06 - 06	754 SI	754 SI
DS	250 Right	06 - 06	767 SI	
	330 Outlander Left	03 - 06	754 SI	754 SI
	330 Outlander Right	03 - 06	767 SI	
	400 Outlander Left	03 - 06	754 SI	754 SI
	400 Outlander Right	03 - 06	767 SI	
	400 Outlander Max Left	03 - 06	754 SI	754 SI
	400 Outlander Max Right	03 - 06	767 SI	
	500 Quest Left	02 - 06	754 SI	754 SI
	500 Quest Right	02 - 06	767 SI	
	500 Traxter 4x4	99 - 00	730 HF*	730 HF
	500 Traxter 4x4 Left	01 - 06	754 SI	767 SI
	500 Traxter 4x4 Right	01 - 06	767 SI	
	500 Traxter Max Left	03 - 05	754 SI	767 SI
	500 Traxter Max Right	03 - 05	767 SI	
	650 Quest Left	02 - 06	754 SI	754 SI
	650 Quest Right	02 - 06	767 SI	
	650 Quest Max Left	03 - 06	754 SI	767 SI
	650 Quest Max Right	03 - 06	767 SI	
	650 Traxter Max Left	03 - 05	754 SI	767 SI
	650 Traxter Max Right	03 - 05	767 SI	
DS	650 Left	01 - 06	754 SI	754 SI
DS	650 Right	01 - 06	767 SI	
	800 Outlander Left	06 - 06	754 SI	754 SI
	800 Outlander Right	06 - 06	767 SI	
	800 Outlander XT Left	06 - 06	754 SI	754 SI
	800 Outlander XT Right	06 - 06	767 SI	
<b>BRAMMO</b>				
	Empulse	14 - 16	706 H.HS*	730 LS
<b>BUELL</b>				
	all models	94 - 97	658 HF	692 HF
	500 Blast	01 - 09	627 HF	614 HF
XB9R	984 Firebolt	02 - 10	795 HS	614 LS
XB9S	984 Lightning	03 - 10	795 HS	614 LS
XB9SX	984 CityX	05 - 10	795 HS	614 LS
	1125 CR	09 - 10	856 HS	857 LS
	1125 R	08 - 10	856 HS	857 LS
M2	1200 Cyclone	98 - 02	676 HS	614 LS
RS	1200	12 - 12	658 HF	692 HF
S1	1200 Lightning	98 - 02	676 HS	614 LS
S1	1200 Whitelightning	98 - 02	676 HS	614 LS
S3	1200 Thunderbolt	98 - 02	676 HS	614 LS
X1	1200 Lightning	01 - 02	676 HS	614 LS
XB12R	1200 Firebolt	04 - 08	795 HS	614 LS
XB12R	1200 Firebolt	09 - 10	856 HS	614 LS
XB12S	1200 Lightning	04 - 08	795 HS	614 LS

**RECOMMENDED**1xx - 2xx = Scooter Pads  
5xx - 9xx = Street, Off Road & Racing Pads  
2xxx = Brake Shoes

			<b>RECOMMENDED</b>	
<b>BUELL</b>				
XB12Scg	1200 Lightning	06 - 08	795 HS	614 LS
XB12Scg	1200 Lightning	09 - 10	856 HS	614 LS
XB12Ss	1200 Lightning Long	06 - 08	795 HS	614 LS
XB12Ss	1200 Lightning Long	09 - 10	856 HS	614 LS
XB12STT	1200 Super TT	07 - 10	795 HS	614 LS
XB12X	1200 Ulysses	06 - 10	795 HS	614 LS
<b>CAGIVA</b>				
	50 AJP Caliper			
	incl. pin/spring	90 - 19	188 HF	
	125 Blues	87 - 85	588 HF	519 HF
	125 Blues	93 - 93	519 HF	519 HF
	125 Cross	86 - 86	608 SI	692 SI
	125 Cruiser	88 - 88	594 HF	519 HF
	125 Cruiser	89 - 89	608 HF	574 HF
	125 E2	86 - 86	574 HF	
	125 Elefant	81 - 88	574 HF	
	125 Enduro	86 - 86	519 HF	
	125 Raptor	03 - 10	566 HF	519 HF
	125 SST	81 - 81	574 HF	
	125 Stella	97 - 08	103 CT	
	125 Tamanaco	87 - 92	608 HF	574 HF
WMX	125	88 - 88	608 SI	
WMX	125	89 - 90	692 SI	692 SI
WMX	125 GP-Replica	86 - 89	519 SI	
WRX	125	85 - 85	519 HF	
	200 Aletta Electra	83 - 83	574 HF	
	200 Cross	83 - 86	574 HF	
	200 Elefant	86 - 86	519 HF	
	250 Cross	86 - 86	608 SI	
MXR	250	82 - 82	519 HF	
WMX	250	89 - 90	608 SI	692 SI
WMX	250 GP	82 - 82	519 SI	
	350 Alazurra	85 - 87	519 HF*	519 HF
	350 Elefant	86 - 89	594 HF	519 HF
T4	350 R	87 - 99	519 HF	2026
	500 Mito	07 - 07	566 HS	519 LS
T4	500 E	87 - 90	519 HF	2026
WMX	500	85 - 86	519 SI	
WMX	500 Cross	87 - 87	519 SI	519 SI
SP	525 Mito	08 - 10	566 HS	519 LS
	650 Alazurra	84 - 84	519 HF	519 HF
	650 Alazurra	85 - 88	560 HF*	560 HF
	650 Elefant	86 - 87	594 HF	519 HF
	650 Raptor	01 - 08	706 HS*	730 LS
	650 V-Raptor	01 - 08	706 HS*	730 LS
	900 Canyon I.E.	97 - 97	647 HS	638 LS
	900 Elefant	93 - 97	671 HF*	671 HF
	900 Gran Canyon	99 - 04	627 HS*	638 LS
	1000 Navigator, T	00 - 05	627 HS*	638 LS
	1000 Raptor	00 - 08	706 HS*	730 LS
	1000 V-Raptor	00 - 08	706 HS*	730 LS
	1000 X3 Raptor	04 - 04	762 HS*	730 LS
	1000 X-Raptor	03 - 04	762 HS*	730 LS
	1000 Xtra Raptor	02 - 06	706 HS*	730 LS
<b>CAN-AM</b>				
DS	50	07 - 11	2048*	2041
DS	70	08 - 14	2048*	2041
DS	90	07 - 18	2048*	2041
DS	90 X	08 - 18	544 SI*	544 SI
	200 ASE	86 - 86	519 SI	
	250 ASE	86 - 86	519 SI	
	250 MX LC	86 - 86	519 SI	
DS	250	08 - 18	810 SI*	810 SI
	350 ASE	86 - 86	519 SI	
	400 Outlander EFI Left	09 - 14	754 SI	754 SI
	400 Outlander EFI Right	09 - 14	767 SI	

\* = 2 sets required / 2 jeux pour l'Avant.



**RECOMMENDED**1xx - 2xx = Scooter Pads  
5xx - 9xx = Street, Off Road & Racing Pads  
2xxx = Brake Shoes**RECOMMENDED**1xx - 2xx = Scooter Pads  
5xx - 9xx = Street, Off Road & Racing Pads  
2xxx = Brake Shoes

CAN-AM				
400 Outlander MAX STD				
Left	07 - 13	754 SI	754 SI	
400 Outlander MAX STD				
Right	07 - 13	767 SI		
400 Outlander MAX XT Left	07 - 13	754 SI	754 SI	
400 Outlander MAX XT				
Right	07 - 13	767 SI		
400 Outlander STD Left	07 - 14	754 SI	754 SI	
400 Outlander STD Right	07 - 14	767 SI		
400 Outlander XT Left	07 - 14	754 SI	754 SI	
400 Outlander XT Right	07 - 14	767 SI		
406 ASE	87 - 87	519 SI		
450 Outlander Left	15 - 18	911 SI		
450 Outlander Right	15 - 18	910 SI	910 SI	
450 Outlander MAX Left	15 - 18	911 SI		
450 Outlander MAX Right	15 - 18	910 SI	910 SI	
DS 450	08 - 12	907 SI*	908 SI	
500 ASE	86 - 86	519 SI		
500 MX	86 - 86	519 SI		
500 Outlander Left	13 - 14	911 SI		
500 Outlander Right	13 - 14	910 SI	910 SI	
500 Outlander MAX Left	13 - 14	911 SI		
500 Outlander MAX Right	13 - 14	910 SI	910 SI	
500 Outlander MAX STD				
Left	07 - 12	754 SI	754 SI	
500 Outlander MAX STD				
Right	07 - 12	767 SI		
500 Outlander MAX XT Left	07 - 12	754 SI	754 SI	
500 Outlander MAX XT				
Right	07 - 12	767 SI		
500 Outlander STD Left	07 - 12	754 SI	754 SI	
500 Outlander STD Right	07 - 12	767 SI		
500 Outlander XT Left	07 - 12	754 SI	754 SI	
500 Outlander XT Right	07 - 12	767 SI		
500 Renegade Left	08 - 11	754 SI	754 SI	
500 Renegade Right	08 - 11	767 SI		
500 Renegade Left	12 - 13	911 SI		
500 Renegade Right	12 - 13	910 SI	910 SI	
500 Renegade Left	14 - 14	911 SI	911 SI	
500 Renegade Right	14 - 14	910 SI	910 SI	
560 Sonic	86 - 14	519 SI		
650 Outlander Left	13 - 15	911 SI		
650 Outlander Right	13 - 15	910 SI	910 SI	
650 Outlander 6x6 Left	14 - 18	911 SI	911 SI	
650 Outlander 6x6 Right	14 - 18	910 SI	910 SI	
650 Outlander MAX Left	13 - 15	911 SI		
650 Outlander MAX Right	13 - 15	910 SI	910 SI	
650 Outlander MAX STD				
Left	07 - 12	754 SI	754 SI	
650 Outlander MAX STD				
Right	07 - 12	767 SI		
650 Outlander MAX XT Left	07 - 12	754 SI	754 SI	
650 Outlander MAX XT				
Right	07 - 12	767 SI		
650 Outlander STD Left	07 - 12	754 SI	754 SI	
650 Outlander STD Right	07 - 12	767 SI		
650 Outlander XT Left	07 - 12	754 SI	754 SI	
650 Outlander XT Right	07 - 12	767 SI		
800 Commander Left	11 - 14	638 SI	611 SI	
800 Commander Right	11 - 14	611 SI		
800 Commander MAX R EFI				
Left	18 - 20	971 PSI	754 PSI	
800 Commander MAX R EFI				
Right	18 - 20	972 PSI		
800 Commander R EFI Left	18 - 18	971 PSI	754 PSI	
800 Commander R EFI				
Right	18 - 18	972 PSI		
800 Outlander Left	12 - 15	911 SI		



CAN-AM				
800 Outlander Right	12 - 15	910 SI	910 SI	
800 Outlander MAX Left	13 - 14	911 SI		
800 Outlander MAX Right	13 - 14	910 SI	910 SI	
800 Outlander MAX LTD				
Left	07 - 11	754 SI	754 SI	
800 Outlander MAX LTD				
Right	07 - 11	767 SI		
800 Outlander MAX STD				
Left	07 - 11	754 SI	754 SI	
800 Outlander MAX STD				
Right	07 - 11	767 SI		
800 Outlander MAX XT Left	07 - 11	754 SI	754 SI	
800 Outlander MAX XT				
Right	07 - 11	767 SI		
800 Outlander STD Left	07 - 11	754 SI	754 SI	
800 Outlander STD Right	07 - 11	767 SI		
800 Outlander XT Left	07 - 11	754 SI	754 SI	
800 Outlander XT Right	07 - 11	767 SI		
800 Renegade Left	08 - 11	754 SI	754 SI	
800 Renegade Right	08 - 11	767 SI		
800 Renegade Left	12 - 13	911 SI		
800 Renegade Right	12 - 13	910 SI	910 SI	
800 Renegade Left	14 - 15	911 SI	911 SI	
800 Renegade Right	14 - 15	910 SI	910 SI	
800 Renegade EFI Left	07 - 11	754 SI	754 SI	
800 Renegade EFI Right	07 - 11	767 SI		
800 Renegade X Left	08 - 11	754 SI	754 SI	
800 Renegade X Right	08 - 11	767 SI		
900 X3 Left	17 - 19	957 PSI	957 PSI	
900 X3 Right	17 - 19	956 PSI	956 PSI	
900 X3 MAX Left	17 - 19	957 PSI	957 PSI	
900 X3 MAX Right	17 - 19	956 PSI	956 PSI	
900 X3 MAX Turbo Left	18 - 19	957 PSI	957 PSI	
900 X3 MAX Turbo Right	18 - 19	956 PSI	956 PSI	
900 X3 MAX Turbo R Left	18 - 19	957 PSI	957 PSI	
900 X3 MAX Turbo R Right	18 - 19	956 PSI	956 PSI	
900 X3 Turbo Left	18 - 19	957 PSI	957 PSI	
900 X3 Turbo Right	18 - 19	956 PSI	956 PSI	
900 X3 Turbo R Left	18 - 19	957 PSI	957 PSI	
900 X3 Turbo R Right	18 - 19	956 PSI	956 PSI	
1000 Commander Left	16 - 17	971 PSI	754 PSI	
1000 Commander Right	16 - 17	972 PSI		
1000 Commander MAX Left	14 - 17	971 PSI	754 PSI	
1000 Commander MAX Right	14 - 17	972 PSI		
1000 Commander MAX R EFI				
Left	18 - 19	971 PSI	754 PSI	
1000 Commander MAX R EFI				
Right	18 - 19	972 PSI		
1000 Commander R EFI Left	18 - 20	971 PSI	754 PSI	
1000 Commander R EFI				
Right	18 - 20	972 PSI		
1000 Maverick Left	14 - 18	971 PSI	754 PSI	
1000 Maverick Right	14 - 18	972 PSI		
1000 Maverick MAX Left	14 - 18	971 PSI	754 PSI	
1000 Maverick MAX Right	14 - 18	972 PSI		
1000 Outlander Left	12 - 15	910 SI	910 SI	
1000 Outlander Right	12 - 15	911 SI		
1000 Outlander 6x6 Left	14 - 18	911 SI	911 SI	
1000 Outlander 6x6 Right	14 - 18	910 SI	910 SI	
1000 Outlander MAX Left	12 - 18	911 SI		
1000 Outlander MAX Right	12 - 18	910 SI	910 SI	
1000 Renegade Left	12 - 13	911 SI		
1000 Renegade Right	12 - 13	910 SI	910 SI	
1000 Renegade Left	14 - 18	911 SI	911 SI	
1000 Renegade Right	14 - 18	910 SI	910 SI	
1330 Spyder F3	15 - 19	900 HS*	948 HS	
1330 Spyder F3 Limited	16 - 19	900 HS*	948 HS	
1330 Spyder F3-S	15 - 19	900 HS*	948 HS	

\* = 2 sets required / 2 jeux pour l'Avant.

Full compound selection, see under "Brake pad 1:1 Drawings" / Sélection complète de composés, voir "1:1 Schémas Plaquettes de frein".

**RECOMMENDED**1xx - 2xx = Scooter Pads  
5xx - 9xx = Street, Off Road & Racing Pads  
2xxx = Brake Shoes

<b>CAN-AM</b>			
	1330 Spyder F3-T	16 - 19	900 HS* 948 HS
	1330 Spyder RS	14 - 16	900 HS* 948 HS
	1330 Spyder RS RSS	13 - 13	900 HS* 948 HS
	1330 Spyder RSS	14 - 15	900 HS* 948 HS
	1330 Spyder RSS Special Series	15 - 15	900 HS* 948 HS
	1330 Spyder RT	14 - 18	900 HS* 948 HS
	1330 Spyder RT Limited	13 - 19	900 HS* 948 HS
	1330 Spyder RT RTS	13 - 13	900 HS* 948 HS
	1330 Spyder RTS	14 - 15	900 HS* 948 HS
	1330 Spyder RTS Special Series	15 - 15	900 HS* 948 HS
	1330 Spyder ST	14 - 16	900 HS* 948 HS
	1330 Spyder ST Limited	13 - 15	900 HS* 948 HS
	1330 Spyder ST STS	13 - 13	900 HS* 948 HS
	1330 Spyder STS	14 - 15	900 HS* 948 HS
	1330 Spyder STS Special Series	15 - 15	900 HS* 948 HS

<b>CANNONDALE</b>			
MX	400	00 - 03	694 RSI 632 RSI
	440 Blaze Left	03 - 03	754 SI 754 SI
	440 Blaze Right	03 - 03	767 SI 767 SI
	440 Cannibal Left	03 - 03	754 SI 754 SI
	440 Cannibal Right	03 - 03	767 SI 767 SI
	440 Glamis Left	03 - 03	754 SI 754 SI
	440 Glamis Right	03 - 03	767 SI 767 SI
	440 Moto Left	03 - 03	754 SI 754 SI
	440 Moto Right	03 - 03	767 SI 767 SI
	440 Speed Left	03 - 03	754 SI 754 SI
	440 Speed Right	03 - 03	767 SI 767 SI
C	440 R	03 - 03	694 RSI 632 RSI
E	440 , A, R	03 - 03	694 RSI 632 RSI
S	440	03 - 03	566 HF 632 HF
X	440	03 - 03	694 RSI 632 RSI

<b>CCM</b>			
	450 MX	08 - 10	671 RSI 790 RSI
GP	450	16 - 16	671 SI 675 SI
604	600 RS	01 - 01	671 HF 675 HF
604E	600 Sport	99 - 01	671 SI 675 SI
604E	600 Supermoto	99 - 01	671 SI 675 SI
C25	600	96 - 98	671 SI 675 SI
	644 DS	03 - 06	671 HF 675 HF
	644 R30	02 - 06	671 HF 675 HF

<b>CECTEK</b>			
	500 EFI Gladiator	09 - 13	810 HF* 544 HF
	500 EFI King Cobra	09 - 13	878 HF* 544 HF
	500 EFI Quadrifit	09 - 11	878 HF* 544 HF
	500 i Estoc	10 - 10	878 HF* 544 HF

<b>CF MOTO</b>			
	125 Papio	17 - 17	688 HF 784 HF
	400 C-Force	18 - 21	986 PSI* 799 SI
	400 NK Efi	17 - 17	674 HS* 675 LS
	450 C-Force L	16 - 17	914 SI* 799 SI
	450 G-Force L	16 - 17	914 SI* 799 SI
	500 C-Force HO	18 - 18	986 PSI* 799 SI
	500 C-Force S	18 - 21	986 PSI* 799 SI
	500 U-Force	18 - 20	986 PSI* 987 PSI
	500 Z-Force	18 - 21	986 PSI* 987 PSI
CF	500 Terralander	13 - 15	914 SI* 799 SI
	550 C-Force	16 - 17	914 SI* 799 SI
	550 U-Force Left	15 - 16	638 SI
	550 U-Force Right	15 - 16	611 SI
	550 Z-Force Left	15 - 16	638 SI
	550 Z-Force Right	15 - 16	611 SI

**RECOMMENDED**1xx - 2xx = Scooter Pads  
5xx - 9xx = Street, Off Road & Racing Pads  
2xxx = Brake Shoes

<b>CF MOTO</b>			
	600 C-Force	19 - 19	986 PSI* 799 SI
	600 C-Force	20 - 21	986 PSI* 987 PSI
	600 C-Force Touring	20 - 21	986 PSI* 987 PSI
CF	625 Terralander	11 - 15	914 SI* 799 SI
	650 NK	14 - 16	674 HS* 675 LS
	650 NK Efi	17 - 17	674 HS* 675 LS
	650 TK	14 - 15	674 HS* 675 LS
	700 CL-X	22 - 22	706 SP* 671 LS
	700 CL-X Sport	22 - 22	841 SP* 730 LS
	800 MT Sport	22 - 22	706 SP* 671 LS
	800 MT Touring	22 - 22	706 SP* 671 LS
	800 U-Force	18 - 21	986 PSI* 987 PSI
	800 Z-Force EX Left	15 - 15	638 SI
	800 Z-Force EX Right	15 - 15	611 SI
	800 Z-Force EX	18 - 21	986 PSI* 987 PSI
	800 Z-Force Trail	18 - 21	986 PSI* 987 PSI
CF	800 Terralander	12 - 14	914 SI* 799 SI
	1000 Z-Force	18 - 19	986 PSI* 987 PSI

<b>COBRA</b>			
CX	50 Big Wheel	10 - 14	794 RSI 794 RSI
CX	50 Junior	07 - 10	794 RSI 794 RSI
CX	50 Junior	11 - 13	794 RSI 794 RSI
CX	50 Senior	07 - 13	794 RSI 794 RSI

<b>CPI</b>			
	50 Aragon Club	07 - 09	141 HF
	50 Aragon GP	06 - 09	141 HF
	50 Aragon SP	07 - 09	141 HF
	50 Baby	02 - 02	101 HF 2028
	50 Freaky	07 - 07	141 HF
	50 GTR	02 - 02	120 HF
	50 GTR	03 - 09	157 HF 123 HF
	50 GTS	02 - 03	120 HF 145 HF
	50 Hussar	01 - 02	101 HF 2028
	50 Hussar	03 - 06	141 HF 2028
	50 Mars	01 - 02	101 HF 2028
	50 Oliver	03 - 12	141 HF 2028
	50 Oliver City	03 - 12	141 HF 2028
	50 Oliver Sport	03 - 12	141 HF 2028
	50 Popcorn	01 - 02	101 HF 2028
	50 Popcorn	03 - 06	141 HF 2032
	50 Supermoto, Supercross	03 - 09	105 HF 105 HF
	125 Aragon GP	07 - 12	141 CT
	125 GTR, GTS	02 - 03	120 CT 143 CT
	125 Sahel	02 - 02	694 HF 604 HF
	125 Supermoto	07 - 12	559 HF
	125 X-Large	02 - 03	157 CT* 157 CT
	200 GTR, GTS	02 - 03	120 CT 143 CT
	200 X-Large	02 - 03	157 CT* 157 CT
	250 XS ATV	07 - 08	810 SI* 810 SI
XS	250 Quad	06 - 08	544 SI* 848 SI

<b>DERBI</b>			
	50 AJP Caliper incl. pin/spring	90 - 19	188 HF
	50 Atlantis	99 - 08	105 HF 2181
	50 Atlantis 4T	04 - 10	105 HF
	50 Atlantis Bullet	04 - 05	105 HF
	50 Atlantis H2O	01 - 01	105 HF
	50 Atlantis H2O Wave	01 - 01	105 HF
	50 Atlantis Wave	01 - 02	105 HF
	50 Aventura	96 - 96	105 HF 2206
	50 Black Devil	04 - 04	168 HF 105 HF
	50 Boulevard	09 - 13	177 HF
	50 DRD Pro corse	06 - 08	189 MS 105 HF
	50 DRD Racing R	05 - 10	168 HF 105 HF
	50 DRD Racing R Ltd.	05 - 05	168 HF 105 HF

\* = 2 sets required / 2 jeux pour l'Avant.



**RECOMMENDED**

1xx - 2xx = Scooter Pads  
5xx - 9xx = Street, Off Road & Racing Pads  
2xxx = Brake Shoes



DERBI				
	50 DRD Racing SM	05 - 05	168 HF	105 HF
	50 DRD Racing SM Ltd.	05 - 05	168 HF	105 HF
	50 Easy	96 - 98	138 HF	2181
	50 Fenix	94 - 07	105 HF	105 HF
	50 Furax	96 - 98	105 HF	105 HF
	50 Hunter	97 - 99	105 HF	2181
	50 Manhattan	99 - 99	105 HF	2181
	50 Predator LC	99 - 02	105 HF	105 HF
	50 Predator O2	00 - 02	105 HF	105 HF
	50 Rambla	06 - 06	105 HF	105 HF
	50 Savannah	91 - 97	105 HF	
	50 Senda DRD Pro SM	05 - 11	157 HF	167 HF
	50 Senda L	99 - 01	105 HF	105 HF
	50 Senda R DRD	03 - 04	148 HF*	105 HF
	50 Senda R, X-Treme	94 - 04	105 HF	105 HF
	50 Senda SM DRD	03 - 04	105 HF*	105 HF
	50 Senda SM DRD			
	Black Edition	03 - 04	168 HF	105 HF
	50 Senda SM, X-Treme	99 - 06	105 HF	105 HF
	50 Sonar	10 - 11	142 HF	
	50 Stinger	96 - 96	105 HF	
	50 Vamos FL	95 - 99	105 HF	2181
	50 Vamos L	95 - 95	105 HF	2181
	50 Vamos R (A.J.P. cal.)	95 - 95	105 HF	2206
	50 Vamos R (Brembo cal.)	95 - 95	123 HF	2206
	50 Variant Sport-R	01 - 13	105 HF	2206
	50 X-Race R	05 - 09	105 HF	105 HF
	50 X-Treme R	05 - 05	105 HF	105 HF
DS	50	88 - 88	559 HF	
FD	50 Yumbo	84 - 84	559 HF	
FD	50 Yumbo Extra	87 - 87	559 HF	
FDS	50	87 - 87	559 HF	
FDT	50	87 - 87	559 HF	
FDT	50 Coppa	85 - 85	559 HF	
FDX	50	89 - 89	559 HF	
GP	50	01 - 01	105 HF	
GP1	50	01 - 03	105 HF	105 HF
GP1	50	05 - 05	730 HF	559 HF
GPR	50 Nude	04 - 10	730 HF	559 HF
GPR	50 R	98 - 03	148 HF	105 HF
GPR	50 Racing	04 - 13	730 HF	559 HF
GPX1	50	06 - 06	189 MS	105 HF
ST	50 Paddock	96 - 99	105 HF	2181
	75 GPR	89 - 89	607 HF	559 HF
	75 Sport, Coppa	84 - 84	559 HF	
GPR	75 Sport	92 - 92	607 HF	559 HF
GPR	80 Cup	04 - 05	821 HS	559 HF*
	100 Atlantis 4T	04 - 06	105 HF	
	100 Atlantis O2/H2O	01 - 01	105 HF	
	125 Atmosphere	99 - 99	148 CT	
	125 Boulevard	03 - 07	167 CT	2205
	125 Mulhacen	07 - 07	774 HF	519 HF
	125 Mulhacen	08 - 11	859 HF	585 HF
	125 Predator	99 - 99	105 CT	
	125 Rambla	08 - 14	108 CT	152 CT
	125 Senda Baja	06 - 12	168 HF	167 CT
	125 Senda DRD SM	10 - 14	157 HF	203 HF
	125 Senda R 4T	04 - 12	774 HF	559 HF
	125 Senda X-Treme SM 4T	04 - 05	774 HF	559 HF
	125 Terra	07 - 07	559 HF	519 HF
	125 Terra	08 - 13	859 HF	585 HF
	125 Terra Adventure	08 - 14	859 HF	585 HF
GP1	125	05 - 06	730 HF	559 HF
GPR	125	05 - 06	821 HS	559 HF*
GPR	125 Nude	05 - 08	821 HS	559 HF*
GPR	125 Racing	09 - 09	821 HS	559 HF*
	150 Boulevard	03 - 09	167 CT	2205
	180 Predator	99 - 99	148 CT	



**RECOMMENDED**

1xx - 2xx = Scooter Pads  
5xx - 9xx = Street, Off Road & Racing Pads  
2xxx = Brake Shoes



DERBI				
DXR	200 Quad (Front disc)	04 - 07	544 SI*	586 SI
DXR	200 Quad (Front drum)	04 - 05	2028	586 SI
DXR	200 Quad (Front drum)	04 - 05	2028	611 SI
	250 RC	85 - 85	519 HF	
DXR	250 Quad (Front disc)	04 - 07	544 SI*	586 SI
DXR	250 Quad (Front drum)	04 - 05	2028	586 SI
DXR	250 Quad (Front drum)	04 - 05	2028	611 SI
GP1	250	05 - 09	730 HF	772 HF
	300 Rambla	08 - 12	108 MS	152 MS
	659 Mulhacen	05 - 05	788 HS	730 LS
	659 Mulhacen	06 - 07	762 HS	730 LS
	659 Mulhacen Cafe	08 - 08	762 HS	730 LS
<b>DUCATI</b>				
	250 Desmo	70 - 77	506 HF	
	350	75 - 78	519 HF	
	350 Desmo	70 - 77	506 HF	
	350 F3	86 - 90	506 HF*	506 HF
	350 GTV	77 - 77	519 HF	519 HF
	350 Indiana	86 - 91	594 HF	519 HF
	350 Paso	86 - 86	519 HF*	519 HF
	350 Sport	77 - 80	519 HF*	519 HF
	400 Monster (Japan)	01 - 06	706 HS	519 LS
	400 Scrambler Sixty Two	16 - 20	674 HS	675 LS
	400 SS, Junior	92 - 97	566 HF*	519 HF
	400 SS, Nuda	92 - 96	566 HF	519 HF
	500 GTV	77 - 82	519 HF*	519 HF
	500 Pantah	85 - 89	519 HF*	519 HF
	500 Sport	77 - 82	506 HF*	506 HF
	500 Sport Desmo	77 - 82	519 HF*	
	500 Twin GTL	75 - 80	519 HF	
	502 Single	93 - 93	566 HF*	519 HF
	502 Supermono	93 - 93	566 HF*	519 HF
	600 Monster	00 - 01	706 HS	519 LS
	600 Pantah TL, SL	78 - 89	506 HF*	506 HF
	600 SL, TL Pantah	76 - 89	506 HF*	519 HF
	600 SS Supersport	95 - 00	566 HF	519 HF
M	600 Monster	94 - 99	566 HF	519 HF
	620 Monster Dark i.e.	02 - 06	706 HS	519 LS
	620 Monster i.e., s.i.e.	02 - 06	706 HS*	519 LS
	620 Multistrada	05 - 06	671 HS*	730 LS
	620 Multistrada Dark	05 - 06	706 HS	730 LS
	620 Sport	03 - 06	706 HS*	730 LS
	650 Indiana	86 - 89	594 HF	519 HF
	650 Pantah	84 - 89	506 HF*	506 HF
	695 Monster	07 - 12	671 HS*	519 LS
	696 Monster	08 - 12	706 HS*	730 LS
	748 , S	99 - 02	706 HS*	519 LS
	748 Biposto	95 - 98	566 HF*	519 HF
	748 R	00 - 00	706 HS*	519 LS
	748 R	01 - 02	762 HS*	519 LS
	748 SP	95 - 97	566 HF*	519 HF
	748 SPS	98 - 99	706 HS*	519 LS
	749 , S	03 - 07	762 HS*	730 LS
	749 R	04 - 07	762 HS*	730 LS
	750 F1	86 - 98	506 HF*	506 HF
	750 GT	74 - 76	506 HF*	
	750 Indiana	85 - 86	594 HF	519 HF
	750 Monster	96 - 99	566 HF*	519 HF
	750 Monster	00 - 01	706 HS*	519 LS
	750 Monster i.e.	02 - 02	706 HS*	519 LS
	750 Paso	86 - 88	506 HF*	519 HF
	750 Sport	74 - 76	523 HF*	
	750 Sport	90 - 90	506 HS*	506 LS
	750 Sport	00 - 02	706 HS	730 LS
	750 SS	74 - 76	506 HF*	506 HF
	750 SS	91 - 98	566 HF	506 HF
	750 SS Supersport	95 - 99	566 HF	519 HF

\* = 2 sets required / 2 jeux pour l'Avant.

Full compound selection, see under "Brake pad 1:1 Drawings" / Sélection complète de composés, voir "1:1 Schémas Plaquettes de frein".

**RECOMMENDED**1xx - 2xx = Scooter Pads  
5xx - 9xx = Street, Off Road & Racing Pads  
2xxx = Brake Shoes

DUCATI				
750 SS, Carenara	92 - 98	566 HF	519 HF	
750 SS, Nuda	92 - 92	566 HF	519 HF	
750 Super Sport	92 - 94	566 HF*	519 HF	
750 Super Sport	00 - 02	706 HS*	730 LS	
795 Monster	12 - 12	706 HS*	730 LS	
796 Hypermotard	10 - 12	706 HS*	730 LS	
796 Monster	11 - 14	706 HS*	730 LS	
796 Monster ABS	11 - 14	706 HS*	730 LS	
797 Monster	17 - 21	900 HS	675 LS	
797 Monster+	17 - 20	900 HS	675 LS	
800 Monster Dark i.e., s i.e.	03 - 07	706 HS*	519 LS	
800 Monster i.e., s i.e.	03 - 07	706 HS*	519 LS	
800 Sport	03 - 06	706 HS*	730 LS	
800 Supersport	03 - 06	706 HS*	730 LS	
803 Monster S2R	05 - 07	671 HS*	519 LS	
803 Monster S2R ABS	05 - 07	671 HS*	519 LS	
803 Scrambler	17 - 18	900 HS	675 LS	
803 Scrambler Classic	15 - 19	900 HS	675 LS	
803 Scrambler CR	17 - 20	900 HS	675 LS	
803 Scrambler CR				
Cafe Racer	17 - 20	900 HS	675 LS	
803 Scrambler DS				
Desert Sled	17 - 22	900 HS	675 LS	
803 Scrambler Enduro	15 - 16	900 HS	675 LS	
803 Scrambler Flat				
Track Pro	16 - 16	900 HS	675 LS	
803 Scrambler Full Throttle	15 - 20	900 HS	675 LS	
803 Scrambler Icon	15 - 22	900 HS	675 LS	
803 Scrambler Icon Dark	20 - 22	900 HS	675 LS	
803 Scrambler Mach 2.0	18 - 18	900 HS	675 LS	
803 Scrambler SCR	20 - 20	900 HS*	675 LS	
803 Scrambler Street				
Classic	17 - 18	900 HS	675 LS	
803 Scrambler Urban				
Enduro	15 - 18	900 HS	675 LS	
803 Scrambler Urban				
Motard	22 - 22	900 SP	675 LS	
821 Hypermotard	13 - 16	900 HS*	730 LS	
821 Hypermotard ABS	13 - 16	900 HS*	730 LS	
821 Hypermotard SP	13 - 16	900 HS*	730 LS	
821 Hypermotard SP ABS	13 - 16	900 HS*	730 LS	
821 Hyperstrada	13 - 16	900 HS*	730 LS	
821 Hyperstrada ABS	13 - 16	900 HS*	730 LS	
821 Monster	14 - 21	900 HS*	730 LS	
821 Monster Dark	15 - 16	900 HS*	730 LS	
821 Monster Stealth	19 - 21	900 HS*	730 LS	
848	08 - 10	706 HS*	730 LS	
848 EVO	11 - 12	841 HS*	730 LS	
848 Streetfighter	12 - 15	706 HS*	730 LS	
848 Streetfighter S	12 - 15	841 HS*	730 LS	
851 Strada	89 - 89	566 HF*	519 HF	
851 Strada	91 - 92	566 HF*	506 HF	
851 Superbike	90 - 90	566 HF*	519 HF	
860 GT	75 - 77	506 HF		
860 GT	85 - 85	506 HF	506 HF	
888 Roche Replica	91 - 91	566 HF*	506 HF	
888 SP V	93 - 93	566 HF*	519 HF	
888 SP4	92 - 95	566 HF*	519 HF	
888 SPO	93 - 93	566 HF*	519 HF	
888 SPS	92 - 95	566 HF*	519 HF	
888 Strada	93 - 93	566 HF*	519 HF	
888 Superbike	93 - 93	566 HF*	519 HF	
899 Panigale	14 - 15	900 HS*	730 LS	
900 FE	97 - 98	566 HF*	519 HF	
900 GTS	77 - 79	506 HF		
900 M, IL Monster	93 - 99	566 HF*	519 HF	
900 Mike Hailwood Replica	85 - 86	506 HF*	506 HF	
900 Monster	00 - 01	706 HS*	519 LS	

**RECOMMENDED**1xx - 2xx = Scooter Pads  
5xx - 9xx = Street, Off Road & Racing Pads  
2xxx = Brake Shoes

DUCATI				
900 Monster i.e.	02 - 02	706 HS*	519 LS	
900 S2 Desmo	85 - 85	506 HF*	506 HF	
900 SL	92 - 97	566 HF*	519 HF	
900 Sport	77 - 78	506 HF*	506 HF	
900 SS	78 - 89	506 HF*	506 HF	
900 SS	90 - 94	566 HF*	519 HF	
900 SS Supersport	95 - 97	566 HF	519 HF	
900 SSR	92 - 92	566 HF*	519 HF	
900 Super Sport	98 - 02	706 HS*	730 LS	
906	900 Paso	89 - 89	506 HF*	519 HF
907	900 I. E.	90 - 93	566 HF*	519 HF
M	900 Street Monster	94 - 99	566 HF*	519 HF
MH	900	00 - 01	706 HS*	519 LS
	916 Biposto	94 - 98	566 HF*	519 HF
	916 Monster S4	01 - 03	706 HS*	519 LS
	916 Sport Touring 4	99 - 01	706 HS*	730 LS
	916 SPS	97 - 98	706 HS*	519 LS
	937 Monster	20 - 22	900 SP*	730 LS*
	937 Monster +	20 - 22	900 SP	730 LS
	939 Hypermotard	16 - 18	900 HS*	730 LS
	939 Hypermotard SP	16 - 18	900 HS*	730 LS
	939 Hyperstrada	16 - 16	900 HS*	730 LS
	939 SuperSport	17 - 20	900 HS*	730 LS
	939 SuperSport S	17 - 20	900 HS*	730 LS
	944 Sport Touring	98 - 03	706 HS*	730 LS
	944 ST2	97 - 03	706 HS*	730 LS
	950 Hypermotard	19 - 22	900 HS*	730 LS
	950 Hypermotard SP	19 - 22	900 HS*	730 LS
	950 Multistrada	17 - 22	900 HS	671 LS
	950 Multistrada S	19 - 22	900 HS	671 LS
	950 Supersport	20 - 22	900 HS*	730 LS
	950 Supersport S	20 - 22	900 HS*	730 LS
	955 Panigale V2	20 - 22	900 SP*	730 LS
	955 Panigale V2 Bayliss	22 - 22	900 SP*	730 LS
	955 Streetfighter V2	22 - 22	900 SP*	730 LS
	959 Panigale	16 - 20	900 HS*	730 LS
	959 Panigale Corse	18 - 20	900 HS*	730 LS
D16RR	990 Desmosedici RR	07 - 08	841 HS*	730 LS
	992 ST3	04 - 07	706 HS*	730 LS
	992 ST3s ABS	06 - 07	706 HS*	730 LS
	996 , SPS	99 - 01	706 HS*	519 LS
	996 Monster S4R	04 - 06	706 HS*	519 LS
	996 R	01 - 01	762 HS*	519 LS
	996 RS (slipper clutch)	00 - 01	762 HS*	519 LS
	996 S	01 - 01	706 HS	519 LS
	996 ST4s	02 - 06	706 HS*	730 LS
	996 ST4s ABS	03 - 06	706 HS*	730 LS
	998 , S	02 - 04	706 HS*	519 LS
	998 Monster S4Rs	06 - 06	762 HS*	730 LS
	998 Panigale V4 R	19 - 21	841 SP*	730 LS
	998 R	02 - 04	762 HS*	519 LS
	998 RS (slipper clutch)	02 - 03	762 HS	519 LS
	998 Superleggera V4	20 - 21	841 SP*	730 LS
	999	03 - 07	762 HS*	730 LS
	999 Monster S4R	07 - 08	762 HS*	730 LS
	999 Monster S4RS	07 - 08	762 HS*	730 LS
	999 R	03 - 07	762 HS*	730 LS
	999 RS (slipper clutch)	04 - 05	762 HS	730 LS
	999 S	03 - 07	762 HS*	730 LS
	1000 /6 Mike Hailwood			
	Replica	85 - 86	506 HF*	506 HF
	1000 Biposto	07 - 08	674 HS*	675 LS
	1000 GT	05 - 10	674 HS*	675 LS
	1000 GT Touring	09 - 10	674 HS*	675 LS
	1000 Hypermotard	06 - 06	762 HS*	730 LS
	1000 Mille Replica	84 - 85	506 HF*	506 HF
	1000 Monster Dark i.e., s i.e.	03 - 06	706 HS*	519 LS
	1000 Monster i.e., s i.e.	03 - 06	706 HS*	519 LS

\* = 2 sets required / 2 jeux pour l'Avant.



**RECOMMENDED**

1xx - 2xx = Scooter Pads  
5xx - 9xx = Street, Off Road & Racing Pads  
2xxx = Brake Shoes



DUCATI				
1000 Monster S2R	06 - 07	706 HS*	730 LS	
1000 Multistrada	07 - 07	706 HS*	730 LS	
1000 Multistrada DS	03 - 06	706 HS*	730 LS	
1000 Multistrada S DS	05 - 06	706 HS*	730 LS	
1000 Paul Smart	05 - 08	674 HS*	675 LS	
1000 S2 Desmo	85 - 85	506 HF*	506 HF	
1000 Sport	05 - 09	674 HS*	675 LS	
1000 Sport S	05 - 09	674 HS*	675 LS	
1000 Supersport DS	03 - 06	706 HS*	730 LS	
1098	07 - 08	841 HS*	730 LS	
1098 R	08 - 10	841 SP*	730 LS	
1098 R Bayliss LE	09 - 10	841 SP*	730 LS	
1098 S	07 - 08	841 HS*	730 LS	
1098 Streetfighter	09 - 14	841 HS*	730 LS	
1098 Streetfighter S	09 - 13	841 HS*	730 LS	
1100 Hypermotard	07 - 09	706 HS*	730 LS	
1100 Hypermotard EVO	10 - 12	706 HS*	730 LS	
1100 Hypermotard EVO SP	10 - 12	841 HS*	730 LS	
1100 Hypermotard S	07 - 09	841 HS	730 LS	
1100 Monster	09 - 13	706 HS*	730 LS	
1100 Monster ABS	09 - 10	706 HS*	730 LS	
1100 Monster EVO	11 - 13	706 HS*	730 LS	
1100 Monster EVO ABS	11 - 13	706 HS*	730 LS	
1100 Monster S	09 - 13	706 HS*	730 LS	
1100 Monster S ABS	09 - 10	706 HS*	730 LS	
1100 Multistrada	07 - 09	706 HS*	730 LS	
1100 Multistrada S	07 - 09	706 HS*	730 LS	
1100 Panigale V4	18 - 21	841 SP*	730 LS	
1100 Panigale V4 S	18 - 21	841 SP*	730 LS	
1100 Panigale V4 S Corse	19 - 19	841 SP*	730 LS	
1100 Panigale V4 SP	21 - 21	841 SP*	730 LS	
1100 Panigale V4 Speciale	18 - 19	841 SP*	730 LS	
1100 Scrambler	18 - 19	900 HS*	675 LS	
1100 Scrambler Dark Pro	20 - 22	900 HS*	675 LS	
1100 Scrambler Desert X	20 - 20	900 SP*	675 LS	
1100 Scrambler Pro	20 - 22	900 HS*	675 LS	
1100 Scrambler Special	18 - 19	900 HS*	675 LS	
1100 Scrambler Sport	18 - 19	900 HS*	675 LS	
1100 Scrambler Sport Pro	20 - 22	900 HS*	675 LS	
1100 Scrambler Tribute Pro	22 - 22	900 SP*	675 LS	
1103 Streetfighter V4	20 - 22	841 SP*	730 LS	
1103 Streetfighter V4 S	20 - 22	841 SP*	730 LS	
1103 Streetfighter V4 SP	22 - 22	841 SP*	730 LS	
1158 Multistrada V4	21 - 21	900 SP*	671 LS	
1158 Multistrada V4 Pikes Peak	22 - 22	841 SP*	671 LS	
1158 Multistrada V4S	21 - 22	841 SP*	671 LS	
1158 Multistrada V4S Sport	21 - 22	841 SP*	671 LS	
1198	09 - 13	841 SP*	730 LS	
1198 S	09 - 12	841 SP*	730 LS	
1198 SP	11 - 12	841 SP*	730 LS	
1199 Panigale	12 - 14	841 SP*	730 LS	
1199 Panigale R	13 - 15	841 SP*	730 LS	
1199 Panigale S	12 - 14	841 SP*	730 LS	
1199 Superleggera	14 - 14	841 SP*	730 LS	
1200 Diavel	11 - 18	901 HS*	674 LS	
1200 Diavel Strada	11 - 14	901 HS*	674 LS	
1200 Monster	14 - 21	900 HS*	730 LS	
1200 Monster 25 Anniversario	19 - 19	841 HS*	730 LS	
1200 Monster R	16 - 19	841 HS*	730 LS	
1200 Monster S	14 - 21	841 HS*	730 LS	
1200 Multistrada	10 - 14	706 SP*	730 LS	
1200 Multistrada	15 - 16	900 SP*	671 LS	
1200 Multistrada Enduro	16 - 18	900 SP*	671 LS	
1200 Multistrada Enduro Pro	18 - 18	900 SP*	671 LS	
1200 Multistrada S	15 - 17	841 SP*	671 LS	
1200 Multistrada S D-air	15 - 17	841 SP*	671 LS	



**RECOMMENDED**

1xx - 2xx = Scooter Pads  
5xx - 9xx = Street, Off Road & Racing Pads  
2xxx = Brake Shoes



DUCATI				
1200 Multistrada S GT	12 - 14	706 SP*	730 LS	
1200 Multistrada S Pikes Peak	11 - 14	706 SP*	730 LS	
1200 Multistrada S Pikes Peak	16 - 17	841 SP*	671 LS	
1200 Multistrada S Sport	10 - 14	706 SP*	730 LS	
1200 Multistrada S Touring	10 - 14	706 SP*	730 LS	
1200 Xdiavel	16 - 18	901 HS*	674 LS	
1200 Xdiavel S	16 - 18	901 HS*	674 LS	
1260 Diavel	19 - 22	900 SP*	674 LS	
1260 Diavel S	19 - 22	901 HS*	674 LS	
1260 Multistrada	18 - 18	841 SP*	671 LS	
1260 Multistrada Enduro	19 - 21	900 SP*	671 LS	
1260 Multistrada S	18 - 19	841 SP*	671 LS	
1260 Multistrada S D-air	18 - 19	841 SP*	671 LS	
1260 Multistrada S Grand Tour	20 - 20	841 SP*	671 LS	
1260 Multistrada S Pikes Peak	18 - 19	841 SP*	671 LS	
1260 Xdiavel	19 - 22	901 SP*	674 LS	
1260 Xdiavel Dark	22 - 22	901 SP*	674 LS	
1260 Xdiavel S	19 - 22	901 SP*	674 LS	
1299 Panigale	15 - 17	841 SP*	730 LS	
1299 Panigale R	15 - 17	841 SP*	730 LS	
1299 Panigale R Final Edition	17 - 20	841 SP*	730 LS	
1299 Panigale S	15 - 17	841 SP*	730 LS	
1299 Panigale S Anniversario	17 - 17	841 SP*	730 LS	
1299 Superleggera	17 - 17	841 SP*	730 LS	
EBR				
1190 RS	12 - 15	856 HS	857 LS	
1190 RX	14 - 15	856 HS	857 LS	
1190 SX	14 - 15	856 HS	857 LS	
ENERGICA				
Ego	15 - 21	901 SP*	730 LS	
Eva EsseEsse9	18 - 21	901 SP*	730 LS	
Eva Ribelle	15 - 21	901 SP*	730 LS	
E-TON				
RXL 150 Viper	07 - 07	2012*	847 SI	
VXL 250 Vector, ST Vector	06 - 07	544 SI*	847 SI	
VTX 300 Vortex, ST Vortex	07 - 07	544 SI*	847 SI	
VXL 300 Vector, ST Vector	07 - 13	544 SI*	847 SI	
EXCELSIOR-HENDERSON				
1386 Deadwood Special	00 - 00	739 H.HS	739 H.LS	
1386 Super X all models	99 - 99	739 H.HS	739 H.LS	
FANTIC				
125 Caballero Flat Track	17 - 17	877 HS	675 LS	
125 Caballero Rally	22 - 22	877 HS	675 HF	
125 Caballero Scrambler	22 - 22	877 HS	675 HF	
125 Trial Professional	87 - 87	595 HF	595 HF	
125 Trial Progress 1	87 - 87	595 HF		
HP1 125 Sport	86 - 86	560 HF*		
HP1 125 Sport	87 - 87	574 HF*		
HP1 125 Strada	85 - 85	595 HF		
XE 125	22 - 22	840 SI	790 SI	
XEF 125 Competition	22 - 22	926 HF	777 HF	
XMF 125 Competition	22 - 22	926 HF	777 HF	
XX 125	20 - 21	840 RSI	790 RSI	
XX 125	22 - 22	965 RSI	790 RSI	
201 Trial Progress 2	87 - 87	595 HF		
241 Trial Progress 2	87 - 87	595 HF		
243 Trial	87 - 90	595 HF	595 HF	
250 Coach	91 - 98	519 HF		
250 K-Roo	93 - 95	559 RSI	559 RSI	

\* = 2 sets required / 2 jeux pour l'Avant.

Full compound selection, see under "Brake pad 1:1 Drawings" / Sélection complète de composés, voir "1:1 Schémas Plaquettes de frein".

**RECOMMENDED**1xx - 2xx = Scooter Pads  
5xx - 9xx = Street, Off Road & Racing Pads  
2xxx = Brake Shoes

FANTIC					
	250 Raider	85 - 85	588 HF		
XE	250	22 - 22	840 SI	790 SI	
XX	250	22 - 22	965 RSI	790 RSI	
XXF	250	22 - 22	965 RSI	790 RSI	
	301 Trial	85 - 91	595 HF		
	301 Trial Progress 2	87 - 87	595 HF		
	303 Trial Professional	87 - 87	595 HF	595 HF	
	305	89 - 90	559 RSI	559 RSI	
	307 Trial	91 - 94	559 RSI	559 RSI	
	343 Trial Progress 2	87 - 87	595 HF	595 HF	
	450 Rally	22 - 22	840 SI	790 SI	
XE	450	22 - 22	965 SI	790 SI	
XXF	450	22 - 22	965 RSI	790 RSI	
	500 Caballero	17 - 17	900 HS	675 LS	
	500 Caballero Explorer	22 - 22	877 HS	675 HF	
	500 Caballero Rally	22 - 22	877 HS	675 HF	
	500 Caballero Scrambler	22 - 22	877 HS	675 HF	
	500 Caballero Six Days	22 - 22	877 HS	675 HF	

**GAS GAS**

MC	E 5	21 - 22	794 RSI	794 RSI	
	50 Wild HP	04 - 07	671 SI*	671 SI	
MC	50	21 - 22	794 RSI	794 RSI	
TXT	50 Boy	01 - 01	815 HF	815 HF	
TXT	50 Boy	04 - 04	559 RSI	559 RSI	
TXT	50 Rookie	02 - 03	815 HF	815 HF	
MC	65	05 - 06	815 HF	815 HF	
MC	65	21 - 22	783 RSI	783 RSI	
TXT	80 Rookie	02 - 03	815 HF	815 HF	
MC	85	21 - 22	671 RSI	791 RSI	
	125 Delta	91 - 91	559 HF		
	125 Enducross	93 - 93	694 SI	586 SI	
	125 Pampera	96 - 03	559 RSI	559 RSI	
	125 Pampera	04 - 13	774 HF	815 HF	
	125 Trial	91 - 91	559 RSI		
EC	125	97 - 99	671 SI	675 SI	
EC	125	00 - 06	694 SI	604 SI	
MC	125	03 - 13	694 RSI	604 RSI	
MC	125	21 - 22	671 RSI	791 RSI	
SM	125	02 - 13	566 HF	604 HF	
TX	125 Randone	12 - 13	802 RSI	803 RSI	
TXT	125	04 - 13	802 RSI	803 RSI	
TXT	125 (Formula cal.)	12 - 13	885 RSI	803 RSI	
TXT	125 GP	19 - 22	963 RSI	803 RSI	
TXT	125 Pro Racing	14 - 14	939 RSI	803 RSI	
TXT	125 Pro Replica	13 - 13	939 RSI	803 RSI	
TXT	125 Racing	19 - 22	963 RSI	803 RSI	
	200 Pampera	99 - 08	559 RSI	559 RSI	
	200 Wild HP	08 - 09	671 SI*	671 SI	
EC	200	99 - 99	671 SI	675 SI	
EC	200	00 - 09	694 SI	604 SI	
EC	200	17 - 17	694 SI	790 SI	
EC	200 Hobby	07 - 16	694 SI	604 SI	
EC	200 Ranger Enduro	19 - 19	671 SI	791 SI	
TX	200	97 - 98	559 RSI	559 RSI	
TXT	200	04 - 10	802 RSI	803 RSI	
XC	200	18 - 19	694 SI	790 SI	
	240 Wild HP	04 - 06	671 SI*	671 SI	
	250 Pampera	96 - 99	559 RSI	559 RSI	
	250 Pampera	02 - 13	774 HF	815 HF	
	250 Trial	89 - 96	559 RSI	559 RSI	
	250 Wild HP	08 - 08	671 SI*	671 SI	
EC	250	97 - 99	671 SI	675 SI	
EC	250	00 - 11	694 SI	604 SI	
EC	250	12 - 20	694 SI	790 SI	
EC	250	21 - 22	671 SI	791 SI	
EC	250 Enduro GP 18	18 - 19	694 SI	790 SI	
EC	250 F	21 - 22	671 SI	791 SI	

**GAS GAS**

EC	250 fse	02 - 11	694 SI	604 SI
GT	250 Contact	92 - 93	559 RSI	559 RSI
MC	250	97 - 99	671 RSI	675 RSI
MC	250	00 - 13	694 SI	604 SI
MC	250	21 - 22	671 RSI	791 RSI
MC	250 F	21 - 22	671 RSI	791 RSI
SM	250	02 - 13	566 HF	604 HF
TXT	250	04 - 07	802 RSI	803 RSI
TXT	250 (Formula cal.)	12 - 13	885 RSI	803 RSI
TXT	250 GP	19 - 22	963 RSI	803 RSI
TXT	250 Pro Racing	14 - 19	939 RSI	803 RSI
TXT	250 Pro Replica	13 - 14	939 RSI	803 RSI
TXT	250 Racing	19 - 22	963 RSI	803 RSI
XC	250	17 - 19	694 SI	790 SI
TX	270	97 - 98	559 RSI	559 RSI
	280 Pampera	04 - 08	774 HF	815 HF
TXT	280	04 - 04	802 RSI	803 RSI
TXT	280 (Formula cal.)	12 - 12	885 RSI	803 RSI
TXT	280 GP	19 - 22	963 RSI	803 RSI
TXT	280 Pro Racing	14 - 19	939 RSI	803 RSI
TXT	280 Pro Replica	13 - 13	939 RSI	803 RSI
TXT	280 Racing	19 - 22	963 RSI	803 RSI
	300 Wild HP	03 - 05	671 SI*	671 SI
EC	300	99 - 99	671 SI	675 SI
EC	300	00 - 11	694 SI	604 SI
EC	300	12 - 20	694 SI	790 SI
EC	300	21 - 22	671 SI	791 SI
EC	300 Enduro GP 18	18 - 19	694 SI	790 SI
EC	300 Ranger Enduro	19 - 19	671 SI	791 SI
TXT	300	04 - 06	802 RSI	803 RSI
TXT	300 (Formula cal.)	12 - 12	885 RSI	803 RSI
TXT	300 GP	19 - 22	963 RSI	803 RSI
TXT	300 Pro	07 - 11	802 RSI	803 RSI
TXT	300 Pro Racing	14 - 19	939 RSI	803 RSI
TXT	300 Pro Replica	13 - 13	939 RSI	803 RSI
TXT	300 Racing	19 - 22	963 RSI	803 RSI
XC	300	18 - 19	694 SI	790 SI
TX	320	97 - 99	559 RSI	559 RSI
	325 Halley PXC	86 - 86	559 RSI	559 RSI
	327 Trial	89 - 90	559 RSI	559 RSI
GT	327 Contact	89 - 90	559 RSI	559 RSI
EC	350 F	21 - 22	671 SI	791 SI
MC	350 F	22 - 22	671 RSI	791 RSI
	370 Pampera	96 - 00	559 RSI	559 RSI
	400 Pampera	06 - 09	694 SI	604 SI
EC	400 fse	02 - 02	694 SI	604 SI
SM	400 fse	02 - 02	566 HF	604 HF
	450 Wild HP	03 - 09	671 SI*	671 SI
EC	450 fse	03 - 15	694 SI	604 SI
EC	450 FSR	07 - 16	694 SI	604 SI
MC	450 F	21 - 22	671 RSI	791 RSI
SM	450 fse	03 - 06	566 HF	604 HF
SM	450 FSR	07 - 13	566 HF	604 HF
	515 Wild HP	09 - 09	671 SI*	671 SI
EC	515 fsr	08 - 16	694 SI	604 SI

**GILERA**

	50 AJP Caliper incl. pin/spring	90 - 19	188 HF	
	50 Sioux	92 - 92	519 HF	519 HF
	80 TG 1, 2, 3	77 - 82	560 HF	
	125 Apache	91 - 94	608 HF	575 HF
	125 Arizona Hawk	86 - 89	519 HF	
	125 Crono	92 - 95	601 HF	519 HF
	125 Fast Bike	88 - 89	588 HF	
	125 Freestyle	92 - 95	601 HF	519 HF
	125 HX, HE	83 - 83	519 HF	
	125 KK, KR, KZ	86 - 91	588 HF	519 HF

\* = 2 sets required / 2 jeux pour l'Avant.

Full compound selection, see under "Brake pad 1:1 Drawings" / Sélection complète de composés, voir "1:1 Schémas Plaquettes de frein".



**RECOMMENDED**

1xx - 2xx = Scooter Pads  
5xx - 9xx = Street, Off Road & Racing Pads  
2xxx = Brake Shoes



**RECOMMENDED**

1xx - 2xx = Scooter Pads  
5xx - 9xx = Street, Off Road & Racing Pads  
2xxx = Brake Shoes



GILERA			
125 MX1, MRX, SP01	89 - 93	601 HF	519 HF
125 R1, R1S	90 - 92	588 HF	519 HF
125 SP02	90 - 94	601 HF	519 HF
125 TG 1, 2, 3 (alu wheels)	77 - 85	560 HF	
125 TG1, GR1, RTX	77 - 85	560 HF	
CX 125	91 - 95	601 HF	519 HF
ER 125 Rally	87 - 87	588 HF	
MXR 125	90 - 90	588 HF	519 HF
RC 125 Top Rally	90 - 93	608 HF	575 HF
RRT 125 Nebraska	87 - 87	588 HF	
RX 125 Arizona Hawk	85 - 85	588 HF	
200 Arizona Hawk	85 - 85	588 HF	
200 ER	87 - 87	588 HF	
200 RX	83 - 83	519 HF	
250 Arizona Hawk	86 - 91	519 HF	
250 Arizona Rally	86 - 91	519 HF	
250 Arizona Rally	08 - 08	588 HF	519 HF
NGR 250	85 - 85	574 HF*	519 HF
350 Dakota	85 - 85	588 HF	
350 Dakota	86 - 89	594 HF	
350 Saturno Bialbero	90 - 90	566 HF	519 HF
XRT 350	90 - 90	588 HF	519 HF
500 Dakota	86 - 86	588 HF	
500 Saturno Bialbero	90 - 90	566 HF	519 HF
500 Saturno Piuma	90 - 94	566 HF	519 HF
600 Northwest	91 - 94	601 HF*	519 HF
600 Supersport	02 - 02	762 HS*	730 LS
RC 600	88 - 88	588 HF	519 HF
RC 600 Top Rally	90 - 94	608 HF	575 HF
XRT 600	89 - 89	588 HF	519 HF

GOES			
360 Max	08 - 14	914 SI*	
520 Max	07 - 12	914 SI*	799 SI
G 520	07 - 12	914 SI*	799 SI
G 525	12 - 14	914 SI*	799 SI
G 620	11 - 14	914 SI*	799 SI
G 625 A	12 - 14	914 SI*	799 SI

HARLEY DAVIDSON			
Livewire	19 - 21	900 H.HS*	730 LS
FLT Series	88 - 99	579 H.HS*	668 H.LS
FXB Series	74 - 77	679 H.HF	
FXE Series	74 - 77	679 H.HF	513 H.HF
XL Series	74 - 77	679 H.HF	
XLH Series	88 - 99	579 H.HS*	669 H.LS
XG 500 Street	14 - 15	924 H.HF	924 H.HF
XG 500 Street	16 - 18	674 H.HF	671 H.HF
XG 750 Street	14 - 15	924 H.HF	924 H.HF
XG 750 Street	16 - 17	674 H.HF	671 H.HF
XG 750 Street Rod	18 - 20	674 H.HF*	671 H.HF
XL 883 C Sportster Custom	04 - 13	807 H.HS	808 H.LS
XL 883 L Sportster Low	06 - 13	807 H.HS	808 H.LS
XL 883 L Super Low	11 - 13	807 H.HS	808 H.LS
XL 883 L Super Low	14 - 18	934 H.HS	715 H.LS
XL 883 N Iron	13 - 13	807 H.HS	808 H.LS
XL 883 N Iron	14 - 18	934 H.HS	715 H.LS
XL 883 R Roadster	10 - 13	807 H.HS*	808 H.LS
XL 883 R Roadster	14 - 15	934 H.HS	715 H.LS
XL 883 R Sportster	00 - 03	826 H.HS	826 H.LS
XL 883 Sportster	04 - 13	807 H.HS	808 H.LS
XL 883 Sportster Custom	00 - 03	826 H.HS	826 H.LS
XL 883 Sportster R	05 - 13	807 H.HS*	808 H.LS
XLH 883	70 - 83	537 H.HF	
XLH 883 Sportster	85 - 86	579 H.HF	549 H.HF
XLH 883 Sportster	87 - 99	579 H.HF	669 H.HF
XLH 883 Sportster	00 - 03	826 H.HS	826 H.LS
XLH 883 Sportster Hugger	00 - 03	826 H.HS	826 H.LS



HARLEY DAVIDSON			
975 Bronx	20 - 21	900 H.HS*	675 H.LS
XL 1000	78 - 78	537 H.HF	543 H.HF
XLCH 1000	73 - 73	513 H.HF	
XLCH 1000	78 - 80	537 H.HF	543 H.HF
XLH 1000 Sportster	79 - 82	537 H.HF*	543 H.HF
XLH 1000 Sportster	83 - 85	537 H.HF*	549 H.HF
XLS 1000 Anniversary	82 - 82	537 H.HF*	549 H.HF
XLS 1000 Roadster	79 - 82	537 H.HF*	543 H.HF
XLS 1000 Sportster	83 - 83	537 H.HF*	549 H.HF
XLX 1000 61	83 - 84	537 H.HF	549 H.HF
XR 1000	85 - 85	537 H.HF*	549 H.HF
XLH 1100	87 - 88	579 H.HS	669 H.LS
XLH 1100 Sportster	85 - 86	579 H.HF	549 H.HF
XLX 1100	86 - 86	579 H.HF	549 H.HF
VRSCA 1130 V-Rod	02 - 05	826 H.HS*	826 H.LS
VRSCA 1130 V-Rod	06 - 10	830 H.HS*	830 H.LS
VRSCB 1130 V-Rod	04 - 04	826 H.HS*	826 H.LS
VRSCD 1130 Night Rod	06 - 08	830 H.HS*	830 H.LS
VRSCR 1130 Street Rod	06 - 07	830 H.HS*	830 H.LS
FL 1200 FLH Police	75 - 79	513 H.HF	513 H.HF
FLH 1200	74 - 76	513 H.HF	513 H.HF
FLH 1200	80 - 80	513 H.HF	553 H.HF
FLH 1200 Anniversary	78 - 78	513 H.HF	513 H.HF
FLH 1200 Touring	77 - 78	513 H.HF	513 H.HF
FLHS 1200	77 - 80	513 H.HF	513 H.HF
FX 1200	74 - 80	537 H.HF	513 H.HF
FXE 1200	74 - 80	537 H.HF	513 H.HF
FXS 1200	78 - 79	537 H.HF	513 H.HF
XL 1200 C Sportster Custom	04 - 13	807 H.HS	808 H.LS
XL 1200 C, CA, CB, CP Custom	14 - 19	934 H.HS	715 H.LS
XL 1200 CX	17 - 17	934 H.HS*	715 H.LS
XL 1200 Iron	18 - 20	934 H.HS*	715 H.LS
XL 1200 L Sportster Low	07 - 10	807 H.HS	808 H.LS
XL 1200 N Nightster	07 - 12	807 H.HS	808 H.LS
XL 1200 R Sportster Roadster	04 - 09	807 H.HS*	808 H.LS
XL 1200 Roadster	18 - 20	934 H.HS*	715 H.LS
XL 1200 Sportster Custom	00 - 03	826 H.HS	826 H.LS
XL 1200 Sportster Sport	00 - 03	826 H.HS*	826 H.LS
XL 1200 T Super Low	15 - 17	934 H.HS	715 H.LS
XL 1200 V Seventy-Two	11 - 13	807 H.HS	808 H.LS
XL 1200 V Seventy-Two	14 - 16	934 H.HS	715 H.LS
XL 1200 X Forty-Eight	11 - 13	807 H.HS	808 H.LS
XL 1200 X Forty-Eight	14 - 18	934 H.HS	715 H.LS
XL 1200 X Forty-Eight Spec.	19 - 20	934 H.HS	715 H.LS
XLH 1200 Sportster	90 - 99	579 H.HS	669 H.LS
XLH 1200 Sportster	00 - 03	826 H.HS	826 H.LS
XR 1200	08 - 10	860 H.HS*	808 H.LS
XR 1200 X	10 - 13	860 H.HS*	808 H.LS
1250 Pan America	21 - 22	900 SP*	675 LS
VRSCAW 1250 V-Rod	08 - 10	830 H.HS*	830 H.LS
VRSCDX 1250 Night Rod Special	08 - 17	830 H.HS*	830 H.LS
VRSCF 1250 Muscle	09 - 17	830 H.HS	830 H.LS
VRSCX 1250 V-Rod	08 - 10	830 H.HS*	830 H.LS
FLH 1340 80	78 - 80	513 H.HF	513 H.HF
FLH 1340 80	81 - 81	513 H.HF	553 H.HF
FLH 1340 Classic	82 - 83	543 H.HF*	553 H.HF
FLH 1340 Electra Glide	82 - 83	543 H.HF*	513 H.HF
FLH 1340 Electra Glide Spec.	84 - 84	513 H.HF	553 H.HF
FLH 1340 Heritage	81 - 81	543 H.HF*	553 H.HF
FLHS 1340 Electra Glide Sport	90 - 90	579 H.HS*	668 H.LS
FLHT 1340 Electra Glide	85 - 86	579 H.HF*	549 H.HF
FLHT 1340 Electra Glide Classic	87 - 99	579 H.HS*	669 H.LS
FLHT 1340 Tour Glide	84 - 84	537 H.HF*	553 H.HF
FLHTC 1340 Electra Glide Classic	85 - 86	579 H.HF*	549 H.HF
FLHTC 1340 Electra Glide Classic	90 - 99	579 H.HS*	668 H.LS
FLHTC 1340 Ultra Classic	90 - 99	579 H.HS*	668 H.LS
FLST 1340 Heritage Softail	86 - 87	579 H.HF	549 H.HF
FLST 1340 Heritage Softail	88 - 99	579 H.HS	668 H.LS

\* = 2 sets required / 2 jeux pour l'Avant.

Full compound selection, see under "Brake pad 1:1 Drawings" / Sélection complète de composés, voir "1:1 Schémas Plaquettes de frein".

**RECOMMENDED**1xx - 2xx = Scooter Pads  
5xx - 9xx = Street, Off Road & Racing Pads  
2xxx = Brake Shoes**HARLEY DAVIDSON**

FLSTC	1340 Heritage Softail Cl.	90 - 99	579 H.HS	669 H.LS
FLSTF	1340 Fat Boy	90 - 99	579 H.HS	669 H.LS
FLSTN	1340 Heritage Softail Nost.	93 - 99	579 H.HS*	669 H.LS
FLT	1340	84 - 85	579 H.HF	553 H.HF
FLT	1340 80	80 - 81	543 H.HF*	553 H.HF
FLT	1340 80 Classic	81 - 81	543 H.HF*	553 H.HF
FLT	1340 Classic	82 - 83	543 H.HF*	553 H.HF
FLT	1340 Tour Glide	82 - 82	543 H.HF*	553 H.HF
FLT/H	1340 Series	86 - 87	579 H.HS*	668 H.LS
FLTC	1340 Tour Glide Classic	85 - 86	579 H.HF	549 H.HF
FLTC	1340 Tour Glide Classic	90 - 90	579 H.HS*	668 H.LS
FXB	1340 80	80 - 81	537 H.HF	513 H.HF
FXB	1340 Sturgis	82 - 82	537 H.HF*	513 H.HF
FXDB	1340 Dyna Glide Daytona	91 - 99	579 H.HS*	669 H.LS
FXDB	1340 Dyna Glide Sturgis	91 - 99	579 H.HF	669 H.LS
FXDB	1340 Sturgis	91 - 99	579 H.HS	669 H.LS
FXDL	1340 Dyna Low Rider	93 - 99	579 H.HS*	669 H.LS
FXDWG	1340 Dyna Wide Glide	93 - 99	579 H.HS	669 H.LS
FXE	1340	82 - 82	537 H.HF	669 H.HF
FXE	1340	85 - 86	579 H.HF	549 H.HF
FXE	1340 80	78 - 81	537 H.HF	513 H.HF
FXE	1340 Super Glide	83 - 84	537 H.HF*	513 H.HF
FXEF	1340 80 Fat Bob	79 - 81	537 H.HF	513 H.HF
FXLR	1340 Low Rider Custom	87 - 99	579 H.HS	669 H.LS
FXR	1340	78 - 81	537 H.HF	513 H.HF
FXR	1340	87 - 88	579 H.HS	669 H.LS
FXR	1340 Super Glide	82 - 83	537 H.HF	549 H.HF
FXR	1340 Super Glide	85 - 86	579 H.HF	549 H.HF
FXR	1340 Super Glide	90 - 99	579 H.HS	669 H.LS
FXRD	1340 Sport Glide GTE	85 - 86	579 H.HF*	549 H.HF
FXRS	1340 Low Glide	82 - 84	537 H.HF*	549 H.HF
FXRS	1340 Low Rider	85 - 86	579 H.HF*	549 H.HF
FXRS	1340 Low Rider Sport	87 - 99	579 H.HS*	669 H.LS
FXRS	1340 Low Rider Sport Ed.	90 - 99	579 H.HS*	669 H.LS
FXRS	1340 Low Rider, Convert.	90 - 99	579 H.HS*	669 H.LS
FXRS	1340 Super Glide II	82 - 83	537 H.HF*	549 H.HF
FXRT	1340 Sport Glide	85 - 86	579 H.HF*	549 H.HF
FXRT	1340 Sport Glide	90 - 99	579 H.HS*	669 H.LS
FXRT	1340 Super Glide II	83 - 83	537 H.HF	549 H.HF
FXS	1340 80	79 - 81	537 H.HF	513 H.HF
FXS	1340 Low Rider	82 - 82	537 H.HF*	513 H.HF
FXSB	1340 Low Rider	83 - 83	537 H.HF*	549 H.HF
FXST	1340 Softail	84 - 86	579 H.HF	549 H.HF
FXSTC	1340 Softail Custom	85 - 86	579 H.HF	549 H.HF
FXSTC	1340 Softail Custom	88 - 99	579 H.HS	669 H.LS
FXSTS	1340 Springer Softail	90 - 99	579 H.HS	669 H.LS
FXWG	1340	87 - 88	579 H.HS	669 H.LS
FXWG	1340 80	80 - 81	537 H.HF	513 H.HF
FXWG	1340 Wide Glide	82 - 82	537 H.HF*	513 H.HF
FXWG	1340 Wide Glide	83 - 84	537 H.HF	549 H.HF
FXWG	1340 Wide Glide	85 - 86	579 H.HF	549 H.HF
FLHR/I	1450 Road King	00 - 06	826 H.HS*	826 H.LS
FLHRCI	1450 Road King Classic	00 - 06	826 H.HS*	826 H.LS
FLHRS/I	1450 Road King Custom	04 - 06	826 H.HS*	826 H.LS
FLHT/I	1450 Electra Glide Standard	00 - 06	826 H.HS*	826 H.LS
FLHTC/I	1450 Electra Glide Classic	00 - 06	826 H.HS*	826 H.LS
FLHTCUI	1450 Ultra Classic Electra Glide	00 - 06	826 H.HS*	826 H.LS
FLHXI	1450 Street Glide	06 - 06	826 H.HS*	826 H.LS
FLSTC	1450 Softail	06 - 07	826 H.HS	826 H.LS
FLSTC/I	1450 Heritage Softail Classic	00 - 04	826 H.HS	826 H.LS
FLSTCI	1450 Softail	06 - 06	826 H.HS	826 H.LS
FLSTF	1450 Fat Boy	06 - 07	826 H.HS	826 H.LS
FLSTF/I	1450 Fat Boy	00 - 04	826 H.HS	826 H.LS
FLSTFI	1450 Fat Boy	06 - 06	826 H.HS	826 H.LS
FLSTI	1450 Heritage Softail	06 - 06	826 H.HS	846 H.LS
FLSTN/I	1450 Softail Deluxe	06 - 06	826 H.HS	826 H.LS
FLSTS/I	1450 Heritage Springer	00 - 03	579 H.HS	826 H.LS

\* = 2 sets required / 2 jeux pour l'Avant.

Full compound selection, see under "Brake pad 1:1 Drawings" / Sélection complète de composés, voir "1:1 Schémas Plaquettes de frein".

**RECOMMENDED**1xx - 2xx = Scooter Pads  
5xx - 9xx = Street, Off Road & Racing Pads  
2xxx = Brake Shoes**HARLEY DAVIDSON**

FLSTSC/I	1450 Springer Softail Classic	06 - 06	579 H.HS	826 H.LS
FLTR/I	1450 Road Glide Classic	00 - 06	826 H.HS*	826 H.LS
FXD	1450 Dyna Super Glide	00 - 03	826 H.HS	826 H.LS
FXDBI	1450 Dyna Street Bob	06 - 06	826 H.HS	826 H.LS
FXDC/I	1450 Dyna Super Glide Custom	05 - 06	826 H.HS	826 H.LS
FXDI	1450 35th Anniversary Super Glide	06 - 06	826 H.HS	846 H.LS
FXDI	1450 Dyna Super Glide	04 - 07	826 H.HS	826 H.LS
FXDL	1450 Dyna Low Rider	00 - 03	826 H.HS*	826 H.LS
FXDLI	1450 Dyna Low Rider	04 - 06	826 H.HS	826 H.LS
FXDS	1450 Dyna Convertible	00 - 02	826 H.HS*	826 H.LS
FXDWG	1450 Dyna Wide Glide	00 - 03	826 H.HS	826 H.LS
FXDWGI	1450 Dyna Wide Glide	04 - 06	826 H.HS	826 H.LS
FXDX	1450 Dyna Super Glide Sport	00 - 03	826 H.HS*	826 H.LS
FXDXI	1450 Dyna Super Glide Sport	04 - 06	826 H.HS	826 H.LS
FXDXT	1450 Dyna Super Glide T-Sport	00 - 03	826 H.HS*	826 H.LS
FXST/I	1450 Softail Standard	00 - 05	826 H.HS	826 H.LS
FXST/I	1450 Softail Standard	06 - 06	826 H.HS	846 H.LS
FXSTB/I	1450 Night Train	00 - 05	826 H.HS	826 H.LS
FXSTB/I	1450 Night Train	06 - 06	826 H.HS	846 H.LS
FXSTD/I	1450 Softail Deuce	00 - 05	826 H.HS	826 H.LS
FXSTD/I	1450 Softail Deuce	06 - 06	826 H.HS	846 H.LS
FXSTS/I	1450 Softail	05 - 05	579 H.HS	826 H.LS
FXSTS/I	1450 Softail	06 - 06	579 H.HS	846 H.LS
FXSTS/I	1450 Springer Softail	00 - 04	579 H.HS	826 H.LS
FLHR	1584 Road King	07 - 07	826 H.HS*	826 H.LS
FLHR	1584 Road King	08 - 10	830 H.HS*	830 H.LS
FLHRC	1584 Road King Classic	07 - 07	826 H.HS*	826 H.LS
FLHRC	1584 Road King Classic	08 - 10	830 H.HS*	830 H.LS
FLHRS	1584 Road King Custom	07 - 07	826 H.HS*	826 H.LS
FLHT	1584 Electra Glide Standard	07 - 07	826 H.HS*	826 H.LS
FLHT	1584 Electra Glide Standard	08 - 10	830 H.HS*	830 H.LS
FLHTC	1584 Electra Glide Classic	07 - 07	826 H.HS*	826 H.LS
FLHTC	1584 Electra Glide Classic	08 - 10	830 H.HS*	830 H.LS
FLHTCi	1584 Ultra Electra Glide Classic	08 - 10	830 H.HS*	830 H.LS
FLHTCU	1584 Ultra Classic Electra Glide	07 - 08	826 H.HS*	826 H.LS
FLHTCU	1584 Ultra Classic Electra Glide	09 - 10	830 H.HS*	830 H.LS
FLHTK	1584 Electra Glide Ultra LTD	10 - 10	830 H.HS*	830 H.LS
FLHX	1584 Street Glide	07 - 07	826 H.HS*	826 H.LS
FLHX	1584 Street Glide	08 - 10	830 H.HS*	830 H.LS
FLSTC	1584 Heritage Softail Classic	07 - 07	826 H.HS	846 H.LS
FLSTC	1584 Heritage Softail Classic	08 - 11	853 H.HS	854 H.LS
FLSTF	1584 Fat Boy	07 - 07	826 H.HS	846 H.LS
FLSTF	1584 Fat Boy	08 - 11	853 H.HS	854 H.LS
FLSTFB	1584 Fat Boy Special	10 - 11	853 H.HS	854 H.LS
FLSTN	1584 Softail Deluxe	07 - 07	826 H.HS	846 H.LS
FLSTN	1584 Softail Deluxe	08 - 11	853 H.HS	854 H.LS
FLSTSC/I	1584 Softail	07 - 07	579 H.HS	846 H.LS
FLTR	1584 Road Glide	08 - 10	830 H.HS*	830 H.LS
FLTRU	1584 Road Glide Ultra	11 - 16	830 H.HS*	830 H.LS
FLTRX	1584 Road Glide Custom	10 - 10	830 H.HS*	830 H.LS
FXCW	1584 Rocker	08 - 09	853 H.HS	854 H.LS
FXCWC	1584 Rocker C	08 - 13	853 H.HS	854 H.LS
FXD	1584 Dyna Super Glide	07 - 07	826 H.HS	826 H.LS
FXD	1584 Dyna Super Glide	08 - 10	853 H.HS	854 H.LS
FXDB	1584 Dyna Street Bob	07 - 07	826 H.HS	826 H.LS
FXDB	1584 Dyna Street Bob	08 - 13	853 H.HS	854 H.LS
FXDC	1584 Dyna Super Glide Custom	07 - 07	826 H.HS	826 H.LS
FXDC	1584 Dyna Super Glide Custom	08 - 13	853 H.HS	854 H.LS
FXDF	1584 Fat Bob	08 - 11	853 H.HS	854 H.LS
FXDL	1584 Dyna Low Rider	07 - 07	826 H.HS	826 H.LS





**RECOMMENDED**

1xx - 2xx = Scooter Pads  
5xx - 9xx = Street, Off Road & Racing Pads  
2xxx = Brake Shoes



HARLEY DAVIDSON					
FXDL	1584 Dyna Low Rider	08 - 13	853 H.HS	854 H.LS	
FXDWG	1584 Dyna Wide Glide	07 - 07	826 H.HS	826 H.LS	
FXDWG	1584 Dyna Wide Glide	08 - 10	853 H.HS	854 H.LS	
FXST	1584 Softail Standard	07 - 07	826 H.HS	846 H.LS	
FXST	1584 Softail Standard	08 - 14	853 H.HS	854 H.LS	
FXST	1584 Softail Standard	15 - 17	860 H.HS	854 H.LS	
FXSTB	1584 Night Train	07 - 07	826 H.HS	846 H.LS	
FXSTB	1584 Night Train	08 - 09	853 H.HS	854 H.LS	
FXSTC	1584 Softail Custom	07 - 07	826 H.HS	846 H.LS	
FXSTC	1584 Softail Custom	08 - 10	853 H.HS	854 H.LS	
FXSTD	1584 Softail Deuce	07 - 07	826 H.HS	846 H.LS	
FLD	1690 Switchback	12 - 16	853 H.HS	854 H.LS	
FLHR	1690 Road King	11 - 16	830 H.HS*	830 H.LS	
FLHRC	1690 Road King Classic	11 - 16	830 H.HS	830 H.LS	
FLHTC	1690 Electra Glide Classic	11 - 16	853 H.HS	854 H.LS	
FLHTCU	1690 Ultra Classic				
	Electra Glide	11 - 16	830 H.HS*	830 H.LS	
FLHTCUL	1690 Electra Glide Ultra				
	Classic Low	15 - 16	830 H.HS*	830 H.LS	
FLHTCUTG	1690 Tri Glide Ultra	14 - 16	922 H.HS*	923 H.LS	
FLHTCUTG	1690 Tri Glide Ultra				
	Classic Trike	09 - 13	830 H.HS*	904 H.LS	
FLHTK	1690 Ultra Classic				
	Electra Glide	10 - 16	830 H.HS*	830 H.LS	
FLHTK	1690 Ultra Electra Glide	11 - 16	853 H.HS	854 H.LS	
FLHTKL	1690 Ultra Limited Low	15 - 16	830 H.HS*	830 H.LS	
FLHX	1690 Street Glide	11 - 16	830 H.HS*	830 H.LS	
FLHXS	1690 Street Glide Special	14 - 16	830 H.HS*	830 H.LS	
FLHXXX	1690 Street Glide Trike	10 - 11	830 H.HS*	904 H.LS	
FLRT	1690 Freewheeler	15 - 16	922 H.HS*	923 H.LS	
FLS	1690 Softail Slim	12 - 14	853 H.HS	854 H.LS	
FLS	1690 Softail Slim	15 - 17	860 H.HS	854 H.LS	
FLSTC	1690 Heritage Softail				
	Classic	12 - 14	853 H.HS	854 H.LS	
FLSTC	1690 Heritage Softail				
	Classic	15 - 17	860 H.HS	854 H.LS	
FLSTF	1690 Fat Boy	12 - 14	853 H.HS	854 H.LS	
FLSTF	1690 Fat Boy	15 - 17	860 H.HS	854 H.LS	
FLSTF	1690 Fat Boy Special	12 - 14	853 H.HS	854 H.LS	
FLSTFB	1690 Fat Boy	12 - 14	853 H.HS	854 H.LS	
FLSTFB	1690 Fat Boy	15 - 17	860 H.HS	854 H.LS	
FLSTN	1690 Softail Deluxe	12 - 14	853 H.HS	854 H.LS	
FLSTN	1690 Softail Deluxe	15 - 17	860 H.HS	854 H.LS	
FLTRX	1690 Road Glide	15 - 16	830 H.HS*	830 H.LS	
FLTRXS	1690 Road Glide Special	15 - 16	830 H.HS*	830 H.LS	
FXDB	1690 Dyna Street Bob	14 - 17	853 H.HS	854 H.LS	
FXDBA	1690 Dyna Street Bob	13 - 17	853 H.HS	854 H.LS	
FXDBB	1690 Dyna Street Bob	14 - 17	853 H.HS	854 H.LS	
FXDBP	1690 Dyna Street Bob	13 - 17	853 H.HS	854 H.LS	
FXDC	1690 Dyna Super Glide				
	Custom	14 - 14	853 H.HS	854 H.LS	
FXDF	1690 Dyna Wide Glide	12 - 17	853 H.HS	854 H.LS	
FXDF	1690 Fat Bob	12 - 17	853 H.HS*	854 H.LS	
FXDL	1690 Dyna Low Rider	14 - 17	853 H.HS*	854 H.LS	
FXDLS	1690 Dyna Low Rider S	17 - 17	853 H.HS*	854 H.LS	
FXS	1690 Blackline	13 - 17	853 H.HS	854 H.LS	
FXSB	1690 Breakout	14 - 14	853 H.HS	854 H.LS	
FXSB	1690 Breakout	15 - 17	860 H.HS	854 H.LS	
FLDE	1750 Softail Deluxe	18 - 19	860 H.HS	949 H.LS	
FLFB	1750 Fat Boy	18 - 20	860 H.HS	949 H.LS	
FLHC	1750 Heritage Classic	18 - 19	860 H.HS	949 H.LS	
FLHR	1750 Road King	17 - 20	830 H.HS*	830 H.LS	
FLHRC	1750 Road King Classic	17 - 17	830 H.HS*	830 H.LS	
FLHRXS	1750 Road King Special	18 - 20	830 H.HS	949 H.LS	
FLHTCU	1750 Ultra Classic Electra				
	Glide	17 - 19	830 H.HS*	830 H.LS	
FLHTCUTG	1750 Tri Glide Ultra	17 - 19	922 H.HS*	923 H.LS	
FLHTK	1750 Ultra Limited	17 - 19	830 H.HS*	830 H.LS	



**RECOMMENDED**

1xx - 2xx = Scooter Pads  
5xx - 9xx = Street, Off Road & Racing Pads  
2xxx = Brake Shoes



HARLEY DAVIDSON				
FLHTKL	1750 Ultra Limited Low	17 - 19	830 H.HS*	830 H.LS
FLHX	1750 Street Glide	17 - 19	830 H.HS*	830 H.LS
FLHX	1750 Street Glide Special	17 - 19	830 H.HS*	830 H.LS
FLHXS	1750 Street Glide Special	17 - 19	830 H.HS*	830 H.LS
FLRT	1750 Freewheeler	17 - 19	922 H.HS*	923 H.LS
FLSB	1750 Sport Glide	18 - 20	860 H.HS*	949 H.LS
FLSL	1750 Softail Slim	18 - 20	860 H.HS	949 H.LS
FLTRU	1750 Road Glide Ultra	17 - 19	830 H.HS*	830 H.LS
FLTRX	1750 Road Glide	17 - 19	830 H.HS*	830 H.LS
FLTRXS	1750 Road Glide Special	17 - 20	830 H.HS*	830 H.LS
FXBB	1750 Street Bob	18 - 20	860 H.HS	949 H.LS
FXBR	1750 Breakout	18 - 19	860 H.HS	949 H.LS
FXFB	1750 Fat Bob	18 - 20	860 H.HS	949 H.LS
FXLR	1750 Low Rider	18 - 20	860 H.HS	949 H.LS
FLHRSE5	1802 CVO Road King	14 - 15	830 H.HS*	830 H.LS
FLHTKSE	1802 CVO Limited	14 - 16	830 H.HS*	830 H.LS
FLHXSE	1802 CVO Street Glide	10 - 16	830 H.HS*	830 H.LS
FLSS	1802 Softail Slim S	16 - 17	860 H.HS	854 H.LS
FLSTFBS	1802 Fat Boy S	16 - 17	860 H.HS	854 H.LS
FLSTNSE	1802 CVO Softail Deluxe	14 - 14	853 H.HS*	854 H.LS
FLSTNSE	1802 CVO Softail Deluxe	15 - 17	860 H.HS*	854 H.LS
FLTRUSE	1802 CVO Road Glide Ultra	11 - 16	830 H.HS	830 H.LS
FXSBSE	1802 CVO Breakout	13 - 14	853 H.HS	854 H.LS
FLFBS	1870 Fat Boy	18 - 19	860 H.HS	949 H.LS
FLHCS	1870 Heritage Classic	18 - 19	860 H.HS	949 H.LS
FLHTKSE	1870 CVO Limited	17 - 17	830 H.HS*	830 H.LS
FLHXSE	1870 CVO Street Glide	17 - 17	830 H.HS*	830 H.LS
FXBRS	1870 Breakout	18 - 20	860 H.HS	949 H.LS
FXDR	1870	19 - 20	860 H.HS	949 H.LS
FXFBS	1870 Fat Bob	18 - 21	860 H.HS*	949 H.LS
FLHTKSE	1917 CVO Limited	18 - 19	830 H.HS*	830 H.LS
FLHXSE	1917 CVO Street Glide	18 - 19	830 H.HS*	830 H.LS
FLTRXSE	1917 CVO Road Glide	18 - 19	830 H.HS*	830 H.LS
<b>HIGHLAND</b>				
	450 MX	06 - 09	671 RSI	675 RSI
	950 V2 Motard	00 - 08	671 HF	675 HF
	950 V2 Outback	99 - 08	671 HF	675 HF
<b>HISUN</b>				
HS	400 UTV Left	15 - 17	638 SI	767 SI
HS	400 UTV Right	15 - 17	611 SI	
HS	500 UTV Left	15 - 17	638 SI	767 SI
HS	500 UTV Right	15 - 17	611 SI	
HS	700 UTV Left	15 - 17	638 SI	767 SI
HS	700 UTV Right	15 - 17	611 SI	
HS	700 UTV (2 cal.rear) Left	15 - 17	638 SI	638 SI
HS	700 UTV (2 cal.rear) Right	15 - 17	611 SI	611 SI
HS	800 UTV (2 cal.rear) Left	15 - 17	638 SI	638 SI
HS	800 UTV (2 cal.rear) Right	15 - 17	611 SI	611 SI
<b>HONDA</b>				
	50 Formula	94 - 98	123 HF	
CB	50 all models	80 - 81	2013	2013
CH	50 P Metropolitan II	02 - 06	2057	2057
CHF	50 Metropolitan	02 - 05	2057	2057
CR	50 RE, RF	84 - 85	2057	2057
CRF	50 F	04 - 21	2010	2010
MB	50 S	80 - 82	100 HF	2013
MBX	50	80 - 82	100 HF	2013
MT	50 S	80 - 93	2013	2013
NA	50 Express	79 - 81	2010	2011
NB	50 ME, Aero	83 - 87	2010	2011
NC	50 Express	77 - 80	2010	2010
NC	50 Express	81 - 83	2010	2011
NH	50 Lead	83 - 83	2012	2011
NH	50 Lead	86 - 93	110 HF	2011
NH	50 Lead	94 - 94	121 HF	2011

\* = 2 sets required / 2 jeux pour l'Avant.

Full compound selection, see under "Brake pad 1:1 Drawings" / Sélection complète de composés, voir "1:1 Schémas Plaquettes de frein".

**RECOMMENDED**1xx - 2xx = Scooter Pads  
5xx - 9xx = Street, Off Road & Racing Pads  
2xxx = Brake Shoes

HONDA					
NH	50 Lead (Drum vers.)	94 - 94	2012		2011
NH	50 Lead SS,MR,MSE	84 - 85	112 HF		2011
NN	50 MD Gyro	84 - 84	2010		2010
NPS	50 Zoomer	01 - 12	2057		2057
NQ	50 D, Spree	84 - 87	2010		2010
NS-1	50	91 - 94	103 HF		2011
NSC	50 Vision	10 - 18	205 HF		
NSR	50	89 - 90	103 HF		2013
PA	50	78 - 81	2010		2074
PA	50	82 - 83	2010		2010
PK	50 Walaroo DX-STD	90 - 01	2057		2012
PX	50	82 - 83	2074		2011
PX	50	84 - 84	2074		
QA	50 K1-K3	87 - 89	2074		2074
QR	50	93 - 03	2010		2057
QR	50 ED, EF	82 - 92	2010		2011
R	50 Monkey	88 - 88	618 HF		2012
SA	50 Elite LX, SR	88 - 93	2010		2011
SA	50 J Vision	88 - 94	2057		2057
SB	50	88 - 89	2010		2010
TG	50 M Gyro S	85 - 86	2010		2010
XR	50 R	00 - 03	2010		2010
Z	50 R, RD	80 - 99	2010		2010
CR	60 RF, RG	85 - 86	2057		2057
ATC	70 all models	78 - 85			2069
ATC	70 K1	76 - 77			2012
C	70 all models	75 - 83	2012		2012
CRF	70 F	04 - 14	2057		2057
CT	70	91 - 94	2010		2010
TRX	70	86 - 87	2048*		2041
XR	70	97 - 12	2057		2057
NS-1	75	92 - 00	119 HF		121 HF
ATC	80	76 - 78			2019
CB	80	80 - 81	100 HF		
CH	80 Elite	85 - 88	2012		2057
CR	80 R	86 - 91	584 SI		2043
CR	80 R, RB	92 - 02	584 RSI		604 RSI
CR	80 R2	85 - 85	2013		2013
CR	80 RA, RB	80 - 81	2013		2013
CR	80 RC	82 - 82	2013		2057
CR	80 RD, RE	83 - 84	2057		2057
CR	80 RF	85 - 85	2057		2043
CRF	80 F	04 - 14	2057		2057
NH	80 Aero	85 - 85	2012		2057
NH	80 MD Lead, Aero	83 - 84	2012		2011
NSR	80 R	87 - 92	103 HF		121 HF
NSR	80 R	93 - 95	119 HF		121 HF
XR	80	79 - 84	2013		2013
XR	80 R	85 - 88	2057		2057
CR	85 R, R Expert	03 - 12	592 RSI		604 RSI
ATC	90 K1, K2, K3	73 - 78			2019
C	90	93 - 02	2013		2013
EZ	90 Cub	90 - 95	2012		2012
NH	90 Yupy	90 - 94	121 HF		2013
TRX	90	93 - 01	2012*		2019
CRF	100 F	04 - 14	2057		2057
NH	100 Lead	00 - 08	104 HF		
NSF	100	06 - 06	688 DC		604 HF
XL	100 all models	78 - 85	2013		2013
XR	100	81 - 84	2013		2013
XR	100 R	85 - 03	2057		2057
AFS	110 Wave	12 - 19	216 HF		
ATC	110 all models	79 - 85			2019
CRF	110 F	13 - 21	2057		2057
NHX	110	08 - 09	125 HF		
NHX	110	10 - 12	104 CT		
NSC	110 Vision	10 - 12	205 HF		
NSC	110 Vision	17 - 20	236 HF		

**RECOMMENDED**1xx - 2xx = Scooter Pads  
5xx - 9xx = Street, Off Road & Racing Pads  
2xxx = Brake Shoes

HONDA					
	125 Monkey	19 - 21	797 HF		784 HF
ANF	125 i Innova	07 - 11	180 CT		2012
ANF	125 Innova	03 - 06	180 CT		2012
ATC	125 ME, MF, MG, MH	84 - 87	2012		2019
C	125 Super Cub	19 - 21	216 CT		
CB	125 R	18 - 20	940 HS		915 HF
CBR	125 R	03 - 10	797 HF		784 HF
CBR	125 R	11 - 18	797 HF		915 HF
CH	125 D, E, Spacy, Elite	83 - 84	2012		2012
CR	125 M2, M3, M4	76 - 78	2013		2013
CR	125 R	79 - 81	2031		2041
CR	125 R	95 - 01	694 RSI		604 RSI
CR	125 R	02 - 07	694 RSI		777 RSI
CR	125 RC	82 - 82	2041		2041
CR	125 RD	83 - 83	2042		2042
CR	125 RE, RF	84 - 85	558 SI		2042
CR	125 RG	86 - 86	558 SI		2047
CR	125 RH, RJ, RK	87 - 94	603 RSI		604 RSI
CRE	125	02 - 07	694 SI		777 SI
CRE	125 RR	11 - 11	859 SI		777 SI
CRF	125 F	14 - 21	694 SI		2057
CT	125 Trail	21 - 21	797 HF		784 HF
MSX	125	14 - 21	797 HF		915 HF
MSX	125 Grom	14 - 21	797 HF		915 HF
MT	125 R	77 - 77	525 HF		2013
MT	125 R	78 - 78	517 HF		2013
NES	125 @	01 - 06	104 CT		2208
NH	125 Lead Scooter	86 - 87	112 CT		2012
NSS	125 Forza	15 - 19	183 CT		193 CT
PCX	125	09 - 17	205 MS		2208
PCX	125	18 - 20	228 CT		2208
PCX	125 (Nissin cal.)	18 - 20	233 CT		2208
PS	125 i	07 - 13	125 CT		2208
RS	125	95 - 03	566 DC		618 RQ
RS	125 R	91 - 94	627 HF*		618 HF
SES	125 Dylan	02 - 07	125 CT		2208
SH	125	02 - 08	125 CT		2208
SH	125	13 - 20	183 CT		193 HF
SH	125 i	09 - 12	192 HF		193 HF
TRX	125	85 - 88	2012*		2019
XL	125 K2	78 - 78	2013		2013
XL	125 K3	79 - 79	2012		2013
XL	125 S	79 - 84	2013		2013
XLR	125 R	98 - 01	694 HF		2013
XR	125 L	03 - 07	694 HF		2013
CBR	150 R	00 - 10	797 HF		784 HF
CH	150 D Elite	85 - 87	2012		2012
CRF	150 F	03 - 06	694 SI		2013
CRF	150 R	07 - 21	592 RSI		777 RSI
NES	150 @	01 - 06	104 CT		2208
NS	150	92 - 95	121 HF		
NSR	150	02 - 02	688 HF		611 HF
PCX	150	12 - 17	205 MS		2208
PCX	150	18 - 20	233 CT		2208
PS	150 i	07 - 11	125 CT		2208
SES	150 Dylan	02 - 06	125 CT		2208
SH	150	02 - 08	125 CT		2208
SH	150	13 - 18	183 CT		193 HF
SH	150 i	09 - 12	192 HF		193 HF
CB	175 K3-K7	74 - 76			2068
CD	175 all models	71 - 78	2019		
ATC	185 A, S, SB	80 - 83	2012		2019
CM	185 T	78 - 79	2023		2069
XL	185 S	79 - 83	2013		2013
ATC	200	81 - 83	2012		2019
ATC	200 E Big Red	82 - 83	2012		2019
ATC	200 ES Big Red	84 - 84	2012		2019
ATC	200 M	84 - 85	2012		2019

\* = 2 sets required / 2 jeux pour l'Avant.



**RECOMMENDED**

1xx - 2xx = Scooter Pads  
5xx - 9xx = Street, Off Road & Racing Pads  
2xxx = Brake Shoes



HONDA					
ATC	200 S	84 - 86	2012	2019	
ATC	200 X	83 - 85	592 SI	562 SI	
ATC	200 X	86 - 87	592 SI	592 SI	
CM	200 TA, TB	80 - 82	2023	2069	
CTX	200	04 - 06	694 SI	2013	
TLR	200 Fatcat	86 - 87	2013	2013	
TLR	200 G, H	86 - 87	2013	2057	
TR	200	86 - 87	2013	2013	
TRX	200	84 - 84	2044*	2019	
TRX	200	90 - 91	2083*	2019	
TRX	200 D Type II	91 - 97	2083*	2019	
TRX	200 SX	86 - 88	2083*	2019	
XL	200 R	83 - 84	2013	2013	
XR	200	80 - 84	2013	2013	
XR	200 R	84 - 02	2013	2013	
XR	200 R, Pro Link	81 - 83	2013	2013	
CRF	230	04 - 09	694 SI	2013	
CRF	230 L	08 - 10	694 SI	604 SI	
CRF	230 M	09 - 12	694 SI	604 SI	
SL	230	97 - 01	694 HF	604 HF	
	250 Cota 4RT	04 - 16	802 RSI	803 RSI	
ATC	250 ES, SX	85 - 87	2019	2024	
ATC	250 R	81 - 81	536 SI	2014	
ATC	250 R	82 - 84	584 SI	562 SI	
ATC	250 R	85 - 86	558 SI	558 SI	
ATC	250 X	85 - 85	558 SI	562 SI	
CA	250 Rebel	90 - 95	638 HF	2058	
CB	250 Nighthawk	91 - 02	2023	2069	
CBF	250	04 - 08	688 HF		
CBR	250 R (Bybre cal)	11 - 11	674 HS	675 LS	
CBR	250 R (Nissin cal)	11 - 13	627 HS	881 LS	
CBR	250 R ABS (Nissin cal)	11 - 13	828 HS	881 LS	
CBR	250 RR	17 - 21	700 HS	881 LS	
CH	250 Elite	85 - 86	2041	2082	
CH	250 Elite	87 - 90	2041	2041	
CM	250 C	82 - 83	2023	2069	
CMX	250 C Rebel	96 - 00	713 HF	2069	
CMX	250 Rebel	85 - 12	551 HF	2069	
CN	250	93 - 04	127 CT	2041	
CN	250 Helix	86 - 87	160 CT	2189	
CR	250 R	81 - 82	2030	2041	
CR	250 R	83 - 83		2042	
CR	250 R	87 - 94	603 RSI	604 RSI	
CR	250 R	95 - 01	694 RSI	604 RSI	
CR	250 R	02 - 07	694 RSI	777 RSI	
CR	250 RE, RF	84 - 85	558 SI	2042	
CR	250 RG	86 - 86	558 SI	2047	
CR	250 RZ, RA	79 - 80	2031	2075	
CRE	250	02 - 07	694 SI	777 SI	
CRF	250 L	13 - 15	859 SI	915 SI	
CRF	250 L ABS	17 - 21	859 SI	915 SI	
CRF	250 M	14 - 18	859 SI	915 SI	
CRF	250 R	04 - 22	694 RSI	777 RSI	
CRF	250 Rally	17 - 19	859 SI	915 SI	
CRF	250 X	04 - 19	694 SI	777 SI	
FL	250 Odyssey	77 - 84	525 HF	2019	
MT	250 K1	74 - 76	2023	2023	
MTX	250 R	86 - 86	558 SI		
NSS	250 Reflex	01 - 07	156 MS	158 MS	
NX	250	88 - 90	603 HF	2029	
PS	250	05 - 06	192 MS		
RS	250 R	91 - 92	622 DC*	614 HF	
RS	250 R	93 - 93	566 DC*	618 RQ	
TL	250	75 - 76	2013	2013	
TRX	250	85 - 87	2044*	2024	
TRX	250 EX Sportrax	01 - 08	592 SI*	2055	
TRX	250 R	86 - 89	603 SI*	558 SI	
TRX	250 R Fourtrax	88 - 88	603 SI*	558 SI	



**RECOMMENDED**

1xx - 2xx = Scooter Pads  
5xx - 9xx = Street, Off Road & Racing Pads  
2xxx = Brake Shoes



HONDA					
TRX	250 Recon	97 - 21	2083*	2055	
TRX	250 X	08 - 13	592 SI*	2055	
TRX	250 X Fourtrax	87 - 87	603 SI*	558 SI	
TRX	250 X Fourtrax	88 - 92	584 SI*	584 SI	
VTR	250	88 - 89	552 HF	2068	
VTR	250	90 - 90	593 HS	2068	
VTR	250	98 - 02	654 HF	614 HF	
XL	250	78 - 79	2070	2023	
XL	250 R	82 - 83	2041	2029	
XL	250 R	84 - 87	558 HF	2013	
XL	250 S	78 - 80	2023	2029	
XL	250 S	81 - 81	2023	2026	
XR	250	79 - 80	2023	2029	
XR	250 L	91 - 92	603 HF	604 HF	
XR	250 L	93 - 97	694 HF	604 HF	
XR	250 R	81 - 83	2030	2029	
XR	250 R	84 - 87	558 SI	2013	
XR	250 R	88 - 89	603 SI	2013	
XR	250 R	90 - 95	603 SI	604 SI	
XR	250 S	96 - 00	694 HF	604 HF	
	Cota 260 4Ride	16 - 19	939 RSI	803 RSI	
	Cota 260 4RT	04 - 16	802 RSI	803 RSI	
	Cota 260 4RT Race Replica	15 - 19	939 RSI	803 RSI	
CB	300	10 - 10	688 HF		
CB	300 R	18 - 21	940 HS	915 HF	
CB	300 R Neo Sports Cafe	19 - 19	940 HS	915 HF	
CBR	300 F	14 - 16	700 HS	881 LS	
CBR	300 F ABS	14 - 17	700 HS	881 LS	
CBR	300 R	14 - 21	700 HS	881 LS	
CMX	300 Rebel	17 - 18	700 HS	881 LS	
	Cota 300 RR	16 - 19	939 RSI	803 RSI	
CRF	300 L	21 - 21	859 SI	915 SI	
CRF	300 Rally	21 - 21	859 SI	915 SI	
SH	300 i	07 - 19	192 MS	193 MS	
SH	300 i SH30	15 - 18	183 MS	193 MS	
TRX	300	88 - 00		2024	
TRX	300 4WD	88 - 00	2085*	2024	
TRX	300 EX	93 - 00	592 SI*	562 SI	
TRX	300 EX Sportrax	01 - 08	592 SI*	592 SI	
TRX	300 X	09 - 09	592 SI*	592 SI	
ADV	350	22 - 22	183 MS	193 MS	
ATC	350 Odyssey	85 - 85	558 SI	562 SI	
ATC	350 X	85 - 85	558 SI	562 SI	
ATC	350 X	86 - 89	603 SI	562 SI	
CB	350 F, F1	73 - 76	501 HF	2024	
CB	350 K4	74 - 74	2071	2024	
FL	350 R Odyssey	85 - 87	2044*	610 HF	
TRX	350 all models	86 - 89	2045	2046	
TRX	350 Rancher /ES 2x4, 4x4	00 - 09	2085*	2207	
XL	350	76 - 78	2070	2023	
XL	350 R	84 - 87	558 HF	2029	
XR	350 R	83 - 83	2042	2013	
XR	350 R	84 - 85	558 SI	2013	
CB	360 G, T	73 - 76	501 HF	2024	
CB	400	81 - 82	542 HF	542 HF	
CB	400 A	77 - 81	526 HF	2058	
CB	400 F, F1, F2	75 - 79	501 HF	2024	
CB	400 Hawk	81 - 85	542 HF	542 HF	
CB	400 N, T, Hawk	78 - 82	526 HF	2058	
CB	400 T1, T2	77 - 78	526 HF	2058	
CB-1	400 (CB 400 F)	89 - 90	627 HS	614 LS	
CM	400 A, T, TZ	79 - 79	526 HF	2058	
CM	400 C	81 - 81	572 HF	2058	
CM	400 E	80 - 81	2071	2058	
CM	400 T	79 - 81	526 HF	2058	
CM	400 T	82 - 84	542 HF	2058	
FJS	400 Silverwing	06 - 08	156 MS	184 MS	

\* = 2 sets required / 2 jeux pour l'Avant.

Full compound selection, see under "Brake pad 1:1 Drawings" / Sélection complète de composés, voir "1:1 Schémas Plaquettes de frein".

**RECOMMENDED**1xx - 2xx = Scooter Pads  
5xx - 9xx = Street, Off Road & Racing Pads  
2xxx = Brake Shoes

HONDA				
FJS	400 Silverwing			
	(Parking Brake)	06 - 08		209 HF
FL	400 R Pilot	89 - 90	2044*	610 HF
RVF	400 RR (NC35)	90 - 96	622 HF*	623 HF
SW-T	400	09 - 13	192 MS	184 MS
SW-T	400 ABS	09 - 14	192 MS	184 MS
TRX	400 AT	04 - 11	2085*	2207
TRX	400 EX Sportrax	01 - 08	592 SI*	592 SI
TRX	400 Fourtrax EX	99 - 00	592 SI*	592 SI
TRX	400 FW Fourtrax Foreman	95 - 02	2085*	2207
TRX	400 X	09 - 12	592 SI*	592 SI
XR	400 R	96 - 04	694 SI	604 SI
TRX	420 FA / FPA	09 - 13	592 SI*	813 SI
TRX	420 FPE / FPM 4x4	09 - 14	592 SI*	
XR	440 R	00 - 03	694 SI	604 SI
CB	450 K5, K6, K7	72 - 77	501 HF	2072
CB	450 SC Nighthawk	82 - 82	561 HF	2058
CB	450 SC Nighthawk	83 - 86	572 HF	2058
CM	450 A, C	82 - 86	542 HF	2058
CMX	450 Rebel	86 - 88	542 HF	2058
CR	450 R	81 - 81	2030	
CRE	450 F	02 - 06	694 SI	777 SI
CRF	450 L	19 - 21	694 RSI	777 RSI
CRF	450 R	02 - 22	694 RSI	777 RSI
CRF	450 R-S	22 - 22	694 RSI	777 RSI
CRF	450 RWE	19 - 22	694 RSI	777 RSI
CRF	450 RX	17 - 22	694 SI	777 SI
CRF	450 X	05 - 22	694 SI	777 SI
TRX	450 EX Sportrax	01 - 05	592 SI*	592 SI
TRX	450 Foreman ES, Foreman S	98 - 04	2085*	2207
TRX	450 R	04 - 09	694 SI*	813 SI
CR	480 R	82 - 82	2030	2041
CR	480 R	83 - 83		2042
	500 Pioneer	15 - 20	982 PSI*	976 PSI
CB	500 F	72 - 75	501 HF	2072
CB	500 F	13 - 21	700 HS	881 LS
CB	500 T	75 - 78	501 HF	2072
CB	500 X	13 - 21	700 HS	881 LS
CBR	500 R	13 - 21	700 HS	881 LS
CMX	500 Rebel	17 - 21	700 HS	881 LS
CMX	500 Rebel S	20 - 20	700 HS	881 LS
CR	500 R	87 - 94	603 RSI	604 RSI
CR	500 R	95 - 01	694 RSI	604 RSI
CR	500 RE, RF	84 - 85	558 SI	2042
CR	500 RG	86 - 86	558 SI	2047
CX	500	78 - 80	517 HF*	2059
CX	500	81 - 81	572 HF*	
CX	500 C	81 - 82	542 HF*	2059
CX	500 Silver W., Turbo	83 - 85	542 HF*	542 HF
CX	500 Turbo	82 - 83	542 HF*	572 HF
CX	500 Z, A, B	79 - 81		2059
FT	500	82 - 84	542 HF*	542 HF
GB	500 T.T.	88 - 92	542 HF	2059
GL	500	82 - 82	572 HF*	542 HF
GL	500 D	81 - 82	542 HF*	2059
GL	500 I	81 - 82	572 HF*	2059
TRX	500 all models	05 - 14	829 SI*	2046
TRX	500 Foreman, Rubicon	00 - 09	2085*	2072
VF	500 F, FII	84 - 86	542 HF*	542 HF
VT	500 C Shadow	83 - 86	542 HF	2058
VT	500 ED	82 - 82	552 HF	2058
XL	500 R	83 - 87	558 HF	2026
XL	500 RC	82 - 82	2077	2026
XL	500 SB	81 - 81	2075	2068
XL	500 SZ	80 - 80	2023	2026
XR	500 R Pro Link	81 - 82	2030	2026
XR	500 R, Pro Link	83 - 84	558 HF	2013

**RECOMMENDED**1xx - 2xx = Scooter Pads  
5xx - 9xx = Street, Off Road & Racing Pads  
2xxx = Brake Shoes

HONDA				
XR	500 SZ, SA	79 - 80		
CB	550 F	75 - 79		2031
CB	550 K	74 - 78		501 HF
CB	550 SC	83 - 84		2072
CBX	550 F, F2	82 - 86		542 HF
CB	599	04 - 04		2058
CB	600 Hornet ABS	07 - 12		552 HF*
CBR	600 F	11 - 13		571 HF
CBR	600 F ABS	11 - 13		627 HS*
CBR	600 F Hurricane	87 - 90		657 LS
CBR	600 F, Super Sport	91 - 94		828 HS*
CBR	600 F3	95 - 98		657 LS
CBR	600 F4, F4 Sport	99 - 06		627 HS*
CBR	600 RR	03 - 04		657 LS
CBR	600 RR	05 - 06		734 HS*
CBR	600 RR	07 - 17		809 HS*
CBR	600 RR	18 - 21		657 LS
FSC	600 Silverwing	01 - 08		809 HS*
FSC	600 Silverwing	09 - 18		834 LS
FSC	600 Silverwing (Parking Brake)	01 - 18		947 SP*
SW-T	600	11 - 13		834 LS
VT	600 C, Shadow	88 - 93		156 MS
VT	600 C, Shadow	94 - 00		184 MS
VT	600 CD Shadow VLX	94 - 00		192 MS
XL	600 R	83 - 86		647 HS
XL	600 V, Transalp	87 - 90		2059
XR	600 R	83 - 87		627 HS*
XR	600 R	88 - 90		2059
XR	600 R	91 - 92		558 HF
XR	600 R	93 - 00		2026
CB	650	79 - 81		558 SI
CB	650	85 - 85		2013
CB	650 C	80 - 85		2013
CB	650 F	14 - 19		603 SI
CB	650 R Neo Sports Cafe	19 - 21		604 SI
CB	650 SC Nighthawk	83 - 85		694 SI
CB	650 SCC Nighthawk	82 - 82		526 HF
CB	650 Z	78 - 81		2027
CBR	650 F	14 - 20		542 HF*
CBR	650 F ABS	14 - 20		2027
CBR	650 R	19 - 21		627 HS*
CX	650 C	83 - 86		881 LS
CX	650 E	83 - 86		881 LS
CX	650 Turbo	83 - 86		940 HS*
FMX	650 Rally	05 - 08		881 LS
GL	650 D	83 - 84		561 HF*
NT	650 Hawk GT	88 - 91		2027
NT	650 V Deauville	98 - 00		526 HF
NT	650 V Deauville	01 - 01		2027
NT	650 V Deauville	02 - 05		627 HS*
NX	650 Dominator J-K	88 - 92		881 LS
TRX	650 FA Rincon	03 - 05		700 HS*
TRX	650 FGA Rincon	04 - 05		881 LS
XR	650 L	93 - 18		940 HS
XR	650 R	00 - 11		542 HF*
DN-01	680	08 - 11		2059
DN-01	680 (Parking Brake)	08 - 11		572 HF*
TRX	680 FA6 Rincon	06 - 15		542 HF
TRX	680 FGA6 Rincon	06 - 15		542 HF
	700 Pioneer	14 - 21		627 HS
CB	700 SC	84 - 86		657 LS
CTX	700	14 - 18		657 LS
CTX	700 D ABS w/DCT	13 - 15		674 HS*
CTX	700 D ABS w/DCT (Parking Brake)	13 - 15		674 HS*
CTX	700 N	14 - 18		735 HS*
CTX	700 ND ABS w/DCT	14 - 15		647 HS

\* = 2 sets required / 2 jeux pour l'Avant.



**RECOMMENDED**

1xx - 2xx = Scooter Pads  
 5xx - 9xx = Street, Off Road & Racing Pads  
 2xxx = Brake Shoes



HONDA				
CTX	700 ND ABS w/DCT (Parking Brake)	14 - 15		879 HF
NC	700 D Integra	12 - 13	828 HS	657 LS
NC	700 D Integra w/DCT (Parking Brake)	12 - 13		879 HF
NC	700 S	12 - 13	627 HS	614 LS
NC	700 SA ABS	12 - 13	828 HS	657 LS
NC	700 SD ABS	12 - 13	828 HS	657 LS
NC	700 SD ABS w/DCT (Parking Brake)	12 - 13		879 HF
NC	700 X	12 - 13	627 HS	614 LS
NC	700 XA ABS	12 - 13	828 HS	657 LS
NC	700 XD ABS	12 - 13	828 HS	657 LS
NC	700 XD ABS w/DCT (Parking Brake)	12 - 13		879 HF
NM4	700 Vultus ABS w/DCT	15 - 15	700 HS	881 LS
NM4	700 Vultus ABS w/DCT (Parking Brake)	15 - 15		879 HF
NT	700 Deauville ABS	06 - 12	828 HS*	736 LS
NT	700 V Varadero, ABS	10 - 13	828 HS*	736 LS
TRX	700 XX	08 - 12	694 SI*	829 SI
VF	700 C Magna	84 - 84	542 HF*	2059
VF	700 C Magna	85 - 86	572 HF*	2046
VF	700 C Magna	87 - 87	542 HF	2046
VF	700 F Interceptor	84 - 85	572 HF*	542 HF
VF	700 S	84 - 85	542 HF*	2059
VFR	700 F Interceptor	88 - 89	627 HS*	614 LS
VFR	700 F, F2	86 - 87	600 HS*	542 LS
VT	700 C Shadow	84 - 85	561 HF*	2059
VT	700 C Shadow	86 - 86	561 HF*	2046
VT	700 C, Shadow	87 - 87	542 HF	2046
ADV	750 X-ADV	17 - 21	940 SP	881 LS
ADV	750 X-ADV (Parking Brake)	17 - 21		879 HF
CB	750 A	76 - 78	501 HF	2027
CB	750 C	80 - 81	526 HF*	2027
CB	750 C	82 - 84	542 HF*	2027
CB	750 C, F, FI, K	85 - 86	542 HF*	2027
CB	750 F	77 - 80	517 HF*	517 HF
CB	750 F	81 - 82	542 HF*	542 HF
CB	750 F1	75 - 76	501 HF	509 HF
CB	750 K	81 - 82	542 HF*	542 HF
CB	750 K Four	77 - 78	501 HF	2027
CB	750 K, L	79 - 80	526 HF*	2027
CB	750 K0-K6 Four	70 - 76	502 HF	2027
CB	750 KZ	82 - 82	542 HF	2027
CB	750 N, F, Seven Fifty	92 - 95	627 HS*	657 LS
CB	750 Nighthawk	91 - 02	627 HS	2059
CB	750 PZ	81 - 84	526 HF	2027
CB	750 SC	82 - 83	572 HF*	2027
CB	750 SS	77 - 79	508 HF*	517 HF
NC	750 D Integra	14 - 19	700 HS	881 LS
NC	750 D Integra w/DCT (Parking Brake)	14 - 19		879 HF
NC	750 S w/DCT	14 - 19	700 HS	881 LS
NC	750 S w/DCT (Parking Brake)	14 - 19		879 HF
NC	750 X w/DCT	14 - 19	700 HS	881 LS
NC	750 X w/DCT (Parking Brake)	14 - 19		879 HF
NC	750 XAE	14 - 19	700 HS	881 LS
VF	750 C	82 - 84	542 HF*	2059
VF	750 C, CD Magna	94 - 98	630 HS	2046
VF	750 C, Magna	88 - 93	542 HF	2046
VF	750 F	83 - 84	542 HF*	542 HF
VF	750 Sport	82 - 83	542 HF*	2059
VFR	750 F	86 - 87	600 HS*	542 LS
VFR	750 F	88 - 98	627 HS*	630 LS
VFR	750 R	88 - 93	622 HS*	623 LS



**RECOMMENDED**

1xx - 2xx = Scooter Pads  
 5xx - 9xx = Street, Off Road & Racing Pads  
 2xxx = Brake Shoes



HONDA				
VT	750 Black Widow	01 - 03	700 HS	2046
VT	750 C	83 - 85	561 HF	2059
VT	750 C, Shadow	86 - 96	542 HF	2046
VT	750 C2 Shadow A.C.E.	97 - 03	700 HS	2046
VT	750 C2 Shadow Spirit	07 - 11	700 HS	2046
VT	750 C2B	11 - 18	700 HS	
VT	750 C2B Phantom	10 - 18	700 HS	2046
VT	750 C2S ABS	13 - 14	828 HS	715 LS
VT	750 C4 Shadow	04 - 05	700 HS	2046
VT	750 CS ABS	13 - 14	828 HS	715 LS
VT	750 RS	11 - 13	700 HS	
VT	750 S	11 - 12	700 HS	
VT	750 Shadow Aero	13 - 18	700 HS	715 LS
PC	800 Pacific Coast	89 - 97	627 HS*	2046
VFR	800 Crossrunner	11 - 13	828 HS*	862 LS
VFR	800 F	14 - 16	809 HS*	862 LS
VFR	800 F	17 - 19	947 HS*	862 LS
VFR	800 FI Interceptor, ABS	02 - 05	735 HS*	736 LS
VFR	800 Interceptor	98 - 01	735 HS*	736 LS
VFR	800 Interceptor	06 - 18	828 HS*	736 LS
VFR	800 Interceptor ABS	06 - 18	828 HS*	736 LS
VFR	800 X Crossrunner	15 - 16	809 HS*	862 LS
VFR	800 X Crossrunner	17 - 18	947 HS*	862 LS
VT	800 C	88 - 94	542 HF	2046
CB	900 C	82 - 82	542 HF*	542 HF
CB	900 F	78 - 80	517 HF*	517 HF
CB	900 F, F2	81 - 84	572 HF*	542 HF
CBR	900 RR Fireblade	92 - 97	622 HS*	657 LS
CBR	900 RR Fireblade	98 - 03	734 HS*	657 LS
	919	02 - 02	622 HS*	657 LS
CBR	929 RR	00 - 01	734 HS*	657 LS
CBR	954 RR	02 - 03	734 HS*	657 LS
	1000 Pioneer	16 - 21	981 PSI*	975 PSI*
	1000 Talon	21 - 21	981 PSI*	975 PSI*
	1000 Talon R	19 - 21	981 PSI*	975 PSI*
	1000 Talon X	19 - 21	981 PSI*	975 PSI*
	1000 Talon X-4	20 - 20	981 PSI*	975 PSI*
CB	1000 C	83 - 84	542 HF*	542 HF
CB	1000 F (Big One)	93 - 97	622 HS*	657 LS
CB	1000 R	08 - 16	809 HS*	862 LS
CB	1000 R	18 - 21	947 HS*	862 LS
CB	1000 R ABS	08 - 16	828 HS*	862 LS
CB	1000 R+ Neo Sports Cafe	18 - 18	947 HS*	862 LS
CBR	1000 F	87 - 88	600 HS*	542 LS
CBR	1000 F	89 - 92	627 HS*	630 LS
CBR	1000 F, FP	93 - 99	685 HS*	685 LS
CBR	1000 RR Fireblade	04 - 05	809 HS*	657 LS
CBR	1000 RR Fireblade	06 - 08	809 HS*	834 LS
CBR	1000 RR Fireblade	09 - 16	809 SP*	834 LS
CBR	1000 RR Fireblade	17 - 22	947 SP*	834 LS
CBR	1000 RR SP	14 - 22	901 SP*	834 LS
CBR	1000 RR SP2	17 - 19	901 SP*	834 LS
CBR	1000 RR-R Fireblade	20 - 22	985 SP*	730 LS
CBR	1000 RR-R SP Fireblade	20 - 21	901 SP*	730 LS
CBR	1000 RR-R SP Fireblade	22 - 22	841 SP*	730 LS
CBX	1000	78 - 80	517 HF*	517 HF
CBX	1000	81 - 82	572 HF*	542 HF
CRF	1000 L Africa Twin	16 - 19	940 SP*	657 LS
CRF	1000 L Africa Twin (Parking Brake)	16 - 19		879 HF
CRF	1000 L Africa Twin Adventure Sports	18 - 19	940 SP*	657 LS
CRF	1000 L Africa Twin Adventure Sports (Parking Brake)	18 - 19		879 HF
GL	1000 Gold Wing	81 - 81	517 HF*	517 HF
GL	1000 Gr. Tour. Gold Wing	81 - 82	517 HF*	517 HF
GL	1000 K1, K2 Gold Wing	75 - 77	508 HF*	509 HF

\* = 2 sets required / 2 jeux pour l'Avant.

Full compound selection, see under "Brake pad 1:1 Drawings" / Sélection complète de composés, voir "1:1 Schémas Plaquettes de frein".

**RECOMMENDED**1xx - 2xx = Scooter Pads  
5xx - 9xx = Street, Off Road & Racing Pads  
2xxx = Brake Shoes

HONDA					
GL	1000 K3 Gold Wing	78 - 79	517 HF*	509 HF	
RC213V-S	1000	16 - 18	901 SP*	730 LS	
RVT	1000 RC51	00 - 06	734 HS*	657 LS	
VF	1000 F, FII	84 - 86	542 HF*	542 HF	
VF	1000 R	84 - 87	542 HF*	542 HF	
VTR	1000 SP-1, SP-2	00 - 06	734 HS*	657 LS	
VTR	1000 Super Hawk	97 - 07	622 HS*	657 LS	
CB	1100	13 - 13	828 HS*	657 LS	
CB	1100 , EX	14 - 19	734 HS*	657 LS	
CB	1100 EX ABS	17 - 19	734 HS*	657 LS	
CB	1100 F	83 - 85	542 HF*	542 HF	
CB	1100 RS ABS	17 - 19	947 HS*	657 LS	
CB	1100 X-11	00 - 03	735 HS*	736 LS	
CBR	1100 XX Super Blackbird	96 - 07	735 HS*	736 LS	
CMX	1100 Rebel	21 - 22	947 SP	881 LS	
CRF	1100 L Africa Twin	20 - 21	940 SP*	657 LS	
CRF	1100 L Africa Twin				
	Adventure Sports	20 - 21	940 SP*	657 LS	
GL	1100 -1, DLX Gold Wing	81 - 87	542 HF*	542 HF	
GL	1100 A Gold Wing	79 - 83	517 HF*	517 HF	
GL	1100 Gold Wing	82 - 83	572 HF*	542 HF	
NT	1100	22 - 22	940 SP*	657 LS	
ST	1100 A6 ABS-TCS-CBS	96 - 01	721 HS*	722 LS	
ST	1100 ABS-TCS	92 - 95	627 HS*	654 LS	
VF	1100 C	83 - 86	572 HF*	542 HF	
VF	1100 S	84 - 85	572 HF*	542 HF	
VT	1100 C Shadow	87 - 93	542 HF	2046	
VT	1100 C Shadow	94 - 96	627 HS*	2046	
VT	1100 C2 Shadow A.C.E.	95 - 04	627 HS	657 LS	
VT	1100 C2 Shadow Sabre	00 - 05	627 HS	657 LS	
VT	1100 C3 Shadow Aero	98 - 04	627 HS	657 LS	
VT	1100 T Shadow	98 - 04	627 HS*	657 LS	
GL	1200 A, I Gold Wing	84 - 86	572 HF*	542 HF	
GL	1200 DX Gold Wing	86 - 87	572 HF*	542 HF	
GL	1200 Gold Wing	84 - 86	572 HF*	542 HF	
VFR	1200 F	10 - 19	869 HS*	862 LS	
VFR	1200 F w/DCT	10 - 19	869 HS*	892 LS	
VFR	1200 F w/DCT				
	(Parking Brake)	10 - 19		879 HF	
VFR	1200 XC Crosstourer	12 - 19	828 SP*	892 LS	
VFR	1200 XDC Crosstourer				
	w/DCT	12 - 19	828 SP*	892 LS	
VFR	1200 XDC Crosstourer				
	w/DCT (Parking Brake)	12 - 19		879 HF	
CB	1300	05 - 13	734 HS*	657 LS	
CB	1300 R	02 - 04	734 HS*	715 LS	
CB	1300 S	11 - 15	828 HS*	657 LS	
CTX	1300	14 - 18	828 HS*	630 LS	
ST	1300 , ABS	02 - 07	735 HS*	722 LS	
ST	1300 , ABS	08 - 13	828 HS*	722 LS	
VT	1300 CX A Fury	10 - 18	627 HS	657 LS	
VT	1300 CX A Fury ABS	10 - 18	828 HS	736 LS	
VT	1300 Interstate	11 - 15	627 HS	657 LS	
VT	1300 Sabre	11 - 13	627 HS	657 LS	
VT	1300 Stateline	11 - 16	627 HS	657 LS	
VTX	1300 C	04 - 09	627 HS	657 LS	
VTX	1300 S	03 - 07	627 HS	657 LS	
GL	1500 Gold Wing Aspencade,				
	Interstate, SE	94 - 00	647 HS*	542 LS	
GL	1500 Gold Wing,				
	Gold Wing SE	88 - 99	647 HS*	542 LS	
GL	1500 Valkyrie	96 - 03	627 HS*	630 LS	
GL	1800 C Valkyrie	14 - 15	734 HS*	880 LS	
GL	1800 Gold Wing	01 - 17	735 HS*	880 LS	
GL	1800 Gold Wing	18 - 21	952 HS*	953 LS	
GL	1800 Gold Wing				
	(Parking Brake)	18 - 20		879 HF	
GL	1800 Gold Wing F6B	13 - 16	735 HS*	880 LS	

**RECOMMENDED**1xx - 2xx = Scooter Pads  
5xx - 9xx = Street, Off Road & Racing Pads  
2xxx = Brake Shoes

HONDA					
NRX	1800 Valkyrie Rune	04 - 05	735 HS*	736 LS	
VTX	1800	01 - 12	735 HS*	736 LS	
HUSABERG					
	all models	89 - 92	608 SI	586 SI	
	all models	93 - 98	671 SI	586 SI	
TE	125	13 - 13	671 SI	791 SI	
FE	250	13 - 13	671 SI	791 SI	
TE	250	11 - 13	671 SI	791 SI	
TE	300	11 - 13	671 SI	791 SI	
	350	91 - 92	608 SI	586 SI	
FE	350	13 - 13	671 SI	791 SI	
FE	390	10 - 13	671 SI	791 SI	
FC	400	99 - 02	671 RSI	675 RSI	
FE	400 ,S,E	99 - 03	671 SI	675 SI	
FS	400 e, c	01 - 03	631 RSI	675 RSI	
FC	450	03 - 08	671 RSI	675 RSI	
FE	450	09 - 13	671 SI	791 SI	
FE	450 e	04 - 08	671 SI	675 SI	
FS	450 c	06 - 08	842 RSI	675 RSI	
FS	450 e, c	03 - 05	631 RSI	675 RSI	
FX	450 e	03 - 08	671 RSI	675 RSI	
FC	470 , e	01 - 02	671 RSI	675 RSI	
FX	470 e	01 - 02	671 RSI	675 RSI	
	500	91 - 98	608 SI	586 SI	
	501 Enduro	91 - 94	608 SI	586 SI	
FC	501	99 - 01	671 RSI	675 RSI	
FE	501	13 - 13	671 SI	791 SI	
FE	501 ,S,E	99 - 04	671 SI	675 SI	
FC	550	01 - 05	671 RSI	675 RSI	
FE	550 e	04 - 08	671 SI	675 SI	
FE	570	09 - 13	671 SI	791 SI	
	600 Enduro	91 - 94	608 SI	586 SI	
FC	600	99 - 01	671 RSI	675 RSI	
FE	600 ,S,E	99 - 02	671 SI	675 SI	
FE	650 e	01 - 08	671 SI	675 SI	
FS	650 e, c	01 - 05	631 RSI	675 RSI	
FS	650 e, c	06 - 08	842 RSI	675 RSI	
FX	650 e	01 - 05	671 RSI	675 RSI	
HUSQVARNA					
	all models	72 - 79	2116	2116	
	all models	87 - 88		2116	
	all models CR,TC,TE,				
	WR	92 - 94	611 SI	536 SI	
	all models TE,TC,WR,				
	CR,AE	89 - 89	608 SI	2116	
	all rear drum models	86 - 86		2117	
EE	5	19 - 22	794 RSI	794 RSI	
	50 Husky Boy J, R, S	01 - 10	559 RSI		
	50 Racing	98 - 98	105 HF		
CR	50 Junior	06 - 06	803 RSI		
CR	50 Pro Senior	06 - 06	803 RSI	794 RSI	
CR	50 Senior	06 - 06	803 RSI	794 RSI	
SM	50	02 - 02	148 HF	105 HF	
TC	50	17 - 22	794 RSI	794 RSI	
TC	50 Mini	22 - 22	794 RSI	794 RSI	
CR	65	12 - 13	783 RSI	872 RSI	
TC	65	17 - 22	783 RSI	783 RSI	
TC	85	14 - 20	885 RSI	872 RSI	
TC	85	21 - 22	671 RSI	791 RSI	
CR	125	83 - 84	2118	2116	
CR	125	85 - 90	519 SI	2117	
CR	125	96 - 04	671 RSI	675 RSI	
CR	125	05 - 13	671 RSI	791 RSI	
CR/RL	125	81 - 82	2117	2116	
CR/WR	125	91 - 91	608 SI	692 SI	
CX	125	84 - 85	519 SI		

\* = 2 sets required / 2 jeux pour l'Avant.



**RECOMMENDED**

1xx - 2xx = Scooter Pads  
5xx - 9xx = Street, Off Road & Racing Pads  
2xxx = Brake Shoes



HUSQVARNA					
SM	125 S	09 - 13	671 HF	675 HF	
SM	125 S 4T	11 - 13	671 HF	675 HF	
SM	125 Supermotard, S	99 - 13	671 HF	675 HF	
TC	125	14 - 22	671 RSI	791 RSI	
TE	125	14 - 16	671 SI	791 SI	
TE	125 4T	11 - 13	671 HF	675 HF	
TX	125	17 - 19	671 SI	791 SI	
WR	125	80 - 80	2117	2116	
WR	125	85 - 90	608 SI	2117	
WR	125	96 - 13	671 SI	675 SI	
WR/XC	125	82 - 82	2117	2117	
WR/XC	125	83 - 84	2118	2117	
WRE	125	96 - 13	671 SI	675 SI	
WRK	125	90 - 90	608 SI	586 SI	
XC	125	85 - 85		2116	
TE	150 i	20 - 22	671 SI	791 SI	
	200 Prof	86 - 86	519 SI*	519 SI	
CR	240	84 - 85	519 SI		
WR	240	87 - 91	608 SI	692 SI	
WRK	240	90 - 90	608 SI	586 SI	
CR	250	81 - 82	2117	2116	
CR	250	83 - 84	2118	2116	
CR	250	85 - 87	519 SI	2117	
CR	250	91 - 91	608 SI	692 SI	
CR	250	96 - 04	671 RSI	675 RSI	
CR	250	05 - 05	671 RSI	791 RSI	
CX	250	84 - 85	519 SI		
FC	250	14 - 22	671 RSI	791 RSI	
FE	250	14 - 22	671 SI	791 SI	
TC	250	02 - 03	671 RSI	675 RSI	
TC	250	04 - 22	671 RSI	791 RSI	
TE	250	02 - 13	671 SI	675 SI	
TE	250	14 - 18	671 SI	791 SI	
TE	250 4T	10 - 13	671 SI	791 SI	
TE	250 i	20 - 22	671 SI	791 SI	
WR	250	96 - 13	671 SI	675 SI	
WR/OR	250	80 - 80	2117	2116	
WR/XC	250	81 - 82	2117	2117	
WR/XC	250	83 - 84	2118	2117	
WR/XC	250	87 - 90	608 SI		
WR	260	90 - 93	608 SI	692 SI	
TC	300	14 - 15	671 RSI	791 RSI	
TE	300	14 - 19	671 SI	791 SI	
TE	300 i	18 - 22	671 SI	791 SI	
WR	300	09 - 13	671 SI	791 SI	
TE	310 4T	10 - 13	671 SI	791 SI	
FC	350	14 - 22	671 RSI	791 RSI	
FE	350	14 - 22	671 SI	791 SI	
TE	350	96 - 13	671 SI	675 SI	
TE	350 Enduro	90 - 90	608 SI	586 SI	
WR	360	98 - 13	671 SI	675 SI	
WR/OR	390	80 - 80	2117	2116	
WR/XC	390	82 - 82	2117	2117	
	400 Enduro	85 - 88	519 SI	2117	
SM	400 R	02 - 02	566 HF	675 HF	
TE	400	01 - 13	671 SI	675 SI	
WR	400	87 - 88	608 SI	2117	
WRX	400	85 - 85	2118	2116	
	401 Svartpilen	17 - 20	877 HS	675 LS	
	401 Vitpilen	17 - 20	877 HS	675 LS	
TE	410	96 - 13	671 SI	675 SI	
	430 Auto	87 - 87	608 SI	2117	
	430 Enduro	85 - 88	519 SI	2116	
CR	430	82 - 82	2117	2116	
CR	430	87 - 89	608 SI	2117	
CR/WR/CS	430	81 - 81	2117	2117	
WR	430	87 - 89	608 SI	2116	
XC	430	87 - 88	608 SI	2117	



**RECOMMENDED**

1xx - 2xx = Scooter Pads  
5xx - 9xx = Street, Off Road & Racing Pads  
2xxx = Brake Shoes



HUSQVARNA					
SMR	449	11 - 13	762 RST	791 RSI	
TC	449	11 - 13	671 RSI	791 RSI	
TE	449	11 - 13	671 SI	791 SI	
FC	450	14 - 22	671 RSI	791 RSI	
FE	450	14 - 22	671 SI	791 SI	
FS	450	15 - 22	841 RST	791 RSI	
SM	450 R	03 - 04	566 HF	675 HF	
SM	450 R	05 - 05	762 RST	675 RSI	
SM	450 R	06 - 13	762 RST	791 RSI	
SM	450 RR	06 - 10	762 RST	791 RSI	
TC	450	02 - 03	671 RSI	675 RSI	
TC	450	04 - 10	671 RSI	791 RSI	
TE	450	02 - 10	671 SI	675 SI	
TE	450	14 - 14	671 SI	791 SI	
CR	500	83 - 84	2118	2116	
CR	500	86 - 87	519 SI	2117	
CX/CR	500	84 - 85	519 SI	2116	
TC	500	86 - 86	519 SI	2117	
WR/XC/AE	500	83 - 84	2118	2117	
XC	500	87 - 88	608 SI	2117	
FE	501	14 - 22	671 SI	791 SI	
	504	83 - 83	519 SI	2117	
	510	87 - 89	608 SI	2117	
	510	90 - 90	608 SI	586 SI	
SM	510 Centennial	06 - 06	762 RST	791 RSI	
SM	510 R	05 - 05	762 RST	675 RSI	
SM	510 R	06 - 10	762 RST	791 RSI	
TC	510	02 - 03	671 RSI	675 RSI	
TC	510	04 - 10	671 RSI	791 RSI	
TE	510	86 - 87	519 SI	2117	
TE	510	02 - 10	671 SI	675 SI	
TE	510 Centennial	04 - 05	671 SI	675 SI	
SMR	511	11 - 13	762 RST	791 RSI	
TE	511	11 - 14	671 SI	791 SI	
	570 Nox	01 - 03	706 HF	675 HF	
SM	570 R	01 - 08	566 HF	675 HF	
TC	570	01 - 13	671 RSI	675 RSI	
TE	570	01 - 13	671 SI	675 SI	
LT	610	00 - 02	706 HF	675 HF	
SM	610 ie	07 - 10	762 RST	791 RSI	
SM	610 Super Motard, S	98 - 00	706 HF	675 HF	
TC	610	96 - 13	671 RSI	675 RSI	
TC	610 Cross	91 - 91	608 SI	692 SI	
TE	610	91 - 95	608 SI	692 SI	
TE	610 Rallye	96 - 13	671 RSI	675 RSI	
SM	630	10 - 10	762 HS	791 HF	
SMR	630	04 - 08	706 RST	675 RSI	
TE	630	10 - 13	671 HS	791 HF	
TE	630	14 - 14	671 SI	791 SI	
STR	650 CRC	07 - 07	762 HF	791 HF	
TR	650 Strada	13 - 13	674 HS	675 LS	
TR	650 Terra	13 - 13	674 HS	675 LS	
	701 Enduro LR	20 - 20	674 HS	675 LS	
	701 Svartpilen	18 - 19	706 HS	675 LS	
	701 Vitpilen	18 - 20	706 HS	675 LS	
FE	701 Enduro	17 - 20	674 HS	675 LS	
SM	701 Supermoto	15 - 20	762 HS	675 LS	
	900 Nuda	12 - 13	706 HS*	675 LS	
	900 Nuda R, ABS	12 - 13	841 HS*	675 LS	
	901 Norden	22 - 22	706 SP*	671 LS	
HYOSUNG					
	50 Avanti	99 - 02	101 HF		
	50 Rush	97 - 01	101 HF		
	50 Sense	98 - 07	101 HF		
	50 Super Cab	95 - 98	101 HF		
	50 Super Cab Plus	98 - 98	101 HF		
SB	50	00 - 03	101 HF		

\* = 2 sets required / 2 jeux pour l'Avant.

Full compound selection, see under "Brake pad 1:1 Drawings" / Sélection complète de composés, voir "1:1 Schémas Plaquettes de frein".

**RECOMMENDED**1xx - 2xx = Scooter Pads  
5xx - 9xx = Street, Off Road & Racing Pads  
2xxx = Brake Shoes

HYOSUNG					
SB	50 P	00 - 03	101 HF		
SD	50	00 - 06	101 HF		
SF	50	99 - 06	101 HF		
	100 Cab	98 - 01	101 HF		
EZ	100	00 - 05	101 HF		
	110 Midas Plus	98 - 04	101 HF	2015	
FX	110 110	02 - 04	101 HF	2015	
KR	110 Master	04 - 05	101 HF	2015	
	125 Aquila	00 - 04	611 HF		
	125 Boomer	03 - 03	123 CT	103 CT	
	125 Cruise II	99 - 06	524 HF		
	125 Cruise II Classic	99 - 06	524 HF		
	125 Cruiser	92 - 06	524 HF		
	125 Exceed	02 - 06	123 CT	103 CT	
	125 GA-4	99 - 99	557 HF		
	125 Grand Prix	98 - 04	123 CT		
	125 Grand Prix Plus	02 - 05	551 HF		
	125 Hyper	99 - 09	123 CT		
	125 V2	99 - 11	627 HF		
GA	125	98 - 06	524 HF		
GA	125 F	00 - 06	524 HF		
GD	125 EXIV	12 - 16	734 HF	544 HF	
GF	125	98 - 04	524 HF		
GPS	125 D	00 - 03	123 CT		
GS	125	99 - 99	524 HF		
GT	125	07 - 10	814 HF*	814 HF	
GT	125 Comet	02 - 03	551 HF		
GT	125 Comet	04 - 06	814 HF	814 HF	
GT	125 Naked	13 - 13	814 HF*	814 HF	
GT	125 R Supersport	07 - 16	814 HF*	814 HF	
GV	125 Aquila	02 - 04	551 HF		
GV	125 Aquila	05 - 11	814 HF		
RT	125 Karion	02 - 06	551 HF		
RT	125 Karion	07 - 09	814 HF*	814 HF	
RX	125	00 - 07	551 HF		
RX	125 SM	07 - 11	814 HF*	814 HF	
TN	125	92 - 95	524 HF		
XRX	125	07 - 09	814 HF*	814 HF	
XRX	125 Offroad	99 - 06	551 HF		
	150 Exceed	02 - 04	123 CT	103 CT	
	150 Grand Prix	98 - 01	123 CT		
	250 Aquila	00 - 09	627 HF		
GD	250 EXIV-R	15 - 17	734 HS	747 HF	
GT	250 Comet	02 - 02	597 HS	556 LS	
GT	250 Comet	03 - 08	814 HF	814 HF	
GT	250 iR	13 - 14	814 HS*	814 LS	
GT	250 iR	15 - 15	734 HS*	747 HF	
GT	250 P	13 - 13	814 HF	814 HF	
GT	250 R	07 - 12	814 HF*	814 HF	
GV	250	02 - 09	551 HF	2014	
GV	250	17 - 18	734 HS	638 HF	
GA	300	98 - 01	557 HF		
GT	300 R	16 - 17	734 HS	747 HF	
GV	300	16 - 17	734 HS	638 HF	
TE	400	05 - 06	536 SI*	649 SI	
XRX	400	05 - 08	551 HF	604 HF	
RX	450 SM	08 - 11	762 HS	675 LS	
TE	450	07 - 11	536 SI*	649 SI	
	600 Comet	02 - 02	597 HS	556 LS	
	600 Comet	03 - 03	551 HF*		
GT	650	04 - 12	814 HS*	814 LS	
GT	650 i	13 - 13	734 HS*	814 LS	
GT	650 i Naked	15 - 15	734 HS*	814 LS	
GT	650 iR	13 - 14	734 HS*	814 LS	
GT	650 iR	15 - 15	734 HS*	747 HF	
GT	650 P	16 - 16	814 HS*	814 LS	
GT	650 R	05 - 13	814 HS*	814 LS	
GT	650 S	05 - 13	814 HS*	814 LS	

**RECOMMENDED**1xx - 2xx = Scooter Pads  
5xx - 9xx = Street, Off Road & Racing Pads  
2xxx = Brake Shoes

HYOSUNG					
GT	650 TTC	07 - 11	814 HS*	814 LS	
GT	650 TTC / Custom Trendkiller	07 - 11	814 HS*	814 LS	
GT	650 X	07 - 11	814 HS*	814 LS	
GV	650 Aquila	04 - 05	551 HF*	769 HF	
GV	650 Aquila	06 - 11	814 HS*	814 LS	
ST	700	11 - 13	734 HS	814 LS	
ST	700 i Deluxe	13 - 13	734 HS	814 LS	
INDIAN					
	Chief	01 - 08	678 H.HS	678 H.LS	
	Scout	01 - 08	678 H.HS	678 H.LS	
	1000 Scout Sixty	16 - 16	929 H.HS	930 H.LS	
	1000 Scout Sixty	17 - 18	674 H.HS	675 H.LS	
	1130 Scout	15 - 16	929 H.HS	930 H.LS	
	1200 Scout	17 - 20	674 H.HS	675 H.LS	
	1200 Scout Bobber	17 - 20	674 H.HS	675 H.LS	
FTR	1200	19 - 20	900 H.HS*	730 LS	
FTR	1200 S	19 - 20	900 H.HS*	730 LS	
	1700 Chief Blackhawk	11 - 13	566 H.HS*	506 H.LS	
	1700 Chief Bomber	10 - 13	566 H.HS*	506 H.LS	
	1700 Chief Classic	10 - 13	566 H.HS*	506 H.LS	
	1700 Chief Dark Horse	10 - 13	566 H.HS*	506 H.LS	
	1700 Chief Deluxe	09 - 13	566 H.HS*	506 H.LS	
	1700 Chief Roadmaster	09 - 13	566 H.HS*	506 H.LS	
	1700 Chief Standard	09 - 13	566 H.HS*	506 H.LS	
	1700 Chief Vintage	09 - 13	566 H.HS*	506 H.LS	
	1800 Challenger	20 - 20	900 H.HS*	630 H.LS	
	1800 Challenger Dark Horse	20 - 20	900 H.HS*	630 H.LS	
	1800 Challenger Limited	20 - 20	900 H.HS*	630 H.LS	
	1800 Chief	15 - 18	782 H.HS*	630 H.LS	
	1800 Chief Classic	14 - 18	782 H.HS*	630 H.LS	
	1800 Chief Dark Horse	15 - 19	782 H.HS*	630 H.LS	
	1800 Chief Vintage	14 - 19	782 H.HS*	630 H.LS	
	1800 Chieftain	14 - 18	782 H.HS*	630 H.LS	
	1800 Chieftain Classic	15 - 18	782 H.HS*	630 H.LS	
	1800 Chieftain Dark Horse	15 - 18	782 H.HS*	630 H.LS	
	1800 Chieftain Limited	15 - 18	782 H.HS*	630 H.LS	
	1800 Dark Horse	16 - 18	782 H.HS*	630 H.LS	
	1800 Roadmaster	15 - 19	782 H.HS*	630 H.LS	
	1800 Roadmaster Classic	15 - 18	782 H.HS*	630 H.LS	
	1800 Roadmaster Elite	15 - 18	782 H.HS*	630 H.LS	
	1800 Springfield	16 - 19	782 H.HS*	630 H.LS	
	1800 Springfield Dark Horse	15 - 20	782 H.HS*	630 H.LS	
ITALJET					
	50 AJP Caliper				
	incl. pin/spring	90 - 19	188 HF		
	50 Bazooka	93 - 02	111 HF		
	50 Cruise	95 - 97	111 HF		
	50 Dragster	99 - 06	105 HF	105 HF	
	50 Formula	94 - 00	117 HF	123 HF	
	50 Formula Air	99 - 00	105 HF		
	50 Formula L.C.	98 - 00	105 HF	105 HF	
	50 Jet-Set	02 - 03	167 HF		
	50 Pista 2	92 - 97	111 HF		
	50 Rollercraft	08 - 12	200 HF	119 HF	
	50 Scoop	93 - 97	111 HF		
	50 Torpedo	98 - 99	105 HF		
	50 Torpedo 4T	01 - 03	105 HF		
	50 Yankee 8	94 - 02	111 HF	111 HF	
SM	50	02 - 05	148 HF		
SX1	50	08 - 10	141 HF		
	80 Formula	94 - 97	117 HF	123 HF	
	100 Millennium 2T	01 - 01	101 HF		
	100 Millennium 2T	01 - 01	167 HF		
	125 Amarcord	08 - 16	121 HF		
	125 Dragster	99 - 03	105 CT	105 CT	
	125 Dragster	20 - 20	151 CT	157 CT	

\* = 2 sets required / 2 jeux pour l'Avant.





**RECOMMENDED**

1xx - 2xx = Scooter Pads  
5xx - 9xx = Street, Off Road & Racing Pads  
2xxx = Brake Shoes



ITALJET				
125 Formula	94 - 03	117 CT	123 CT	
125 Formula L.C.	99 - 03	105 CT	105 CT	
125 Jet-Set	02 - 03	167 CT		
125 Jupiter	02 - 03	128 CT	105 CT	
125 Millennium	00 - 03	101 CT		
125 Millennium	00 - 03	167 CT		
125 Torpedo	99 - 06	105 CT		
125 Torpedo	08 - 11	200 CT	119 CT	
125 Twin	98 - 01	105 CT	105 CT	
SM 125	02 - 05	652 HF		
150 Jet-Set	02 - 03	167 CT		
150 Jupiter	02 - 03	128 CT	105 CT	
150 Millennium	00 - 03	101 CT		
150 Millennium	00 - 03	167 CT		
150 Torpedo	08 - 12	200 CT	119 CT	
150 Torpedo 4T	01 - 01	105 CT		
180 Dragster	99 - 03	105 CT	105 CT	
200 Dragster	20 - 20	151 CT	157 CT	
250 Jupiter	01 - 03	128 CT	173 CT	
350	83 - 83	519 HF*		
650 Bazooka	06 - 06	814 HS*	814 LS	
650 Grifon	06 - 07	814 HS*	814 LS	
900 Grifon	00 - 00	566 HF		
<b>JAWA</b>				
CZ 125 2T	95 - 00	506 HF		
CZ 125 MX	95 - 00	506 HF		
CZ 180	92 - 92	506 HF		
300 Trail	93 - 93	506 HF		
350	93 - 95	699 HF		
<b>JOHN DEERE</b>				
HPX 350 Gator	10 - 14	908 SI*	908 SI*	
500 Buck Left	05 - 05	754 SI	767 SI	
500 Buck Right	05 - 05	767 SI		
500 Buck EX, EXT Left	05 - 05	754 SI	767 SI	
500 Buck EX, EXT Right	05 - 05	767 SI		
500 Trail Buck Left	05 - 05	754 SI	767 SI	
500 Trail Buck Right	05 - 05	767 SI		
XUV 625 Gator	11 - 11	912 ATS*		
650 Trail Buck Left	05 - 05	754 SI	767 SI	
650 Trail Buck Right	05 - 05	767 SI		
650 Trail Buck EX, EXT Left	05 - 05	754 SI	767 SI	
650 Trail Buck EX, EXT Right	05 - 05	767 SI		
XUV 825 Gator	11 - 11	912 ATS*		
XUV 855 D Gator	11 - 11	912 ATS*		
<b>JOTAGAS</b>				
JT 125	14 - 19	939 RSI	803 RSI	
JT 250	14 - 19	939 RSI	803 RSI	
JT 280	14 - 19	939 RSI	803 RSI	
JT 300	14 - 19	939 RSI	803 RSI	
<b>KAWASAKI</b>				
AE 50	81 - 82	2015	2015	
AR 50	81 - 82	544 HF	2015	
KX 60	83 - 03	2093	2093	
KX 65	00 - 21	752 RSI	536 RSI	
KD 80	80 - 87	2015	2015	
KD 80	88 - 90	544 HF	2015	
KX 80	79 - 82	2087	2087	
KX 80	83 - 83	2092	2093	
KX 80	84 - 87	544 SI	2093	
KX 80	88 - 96	544 RSI	592 RSI	
KX 80	97 - 00	726 RSI	592 RSI	
KX 85	01 - 22	726 RSI	592 RSI	
KX 85 II	01 - 22	726 RSI	592 RSI	



**RECOMMENDED**

1xx - 2xx = Scooter Pads  
5xx - 9xx = Street, Off Road & Racing Pads  
2xxx = Brake Shoes



KAWASAKI				
KE 100	79 - 97	2015	2015	
KH 100	76 - 77	2015	2015	
KH 100	78 - 81	2014	2015	
KM 100	78 - 81	2015	2015	
KX 100	88 - 96	544 RSI	592 RSI	
KX 100	97 - 21	726 RSI	592 RSI	
KLF 110 Mojave	87 - 88	2015*	2183	
KLT 110	84 - 86	2015	2183	
KLX 110	02 - 21	2093	2015	
KX 112	22 - 22	726 RSI	592 RSI	
125 Ninja	19 - 19	638 HF	638 HF	
J 125	15 - 19	183 CT	204 CT	
KE 125	76 - 85	2039	2183	
KE 125	86 - 91	546 HF	2014	
KLX 125	10 - 14	611 HF	536 HF	
KLX 125 D-Tracker	10 - 14	611 HF	536 HF	
KLX 125 L	03 - 06	702 SI		
KX 125	74 - 81	2039	2183	
KX 125	82 - 82	544 SI	2183	
KX 125	83 - 85	546 SI	2025	
KX 125	86 - 86	546 RSI	586 RSI	
KX 125	87 - 88	602 HF	586 SI	
KX 125	89 - 93	611 RSI	632 RSI	
KX 125	94 - 94	694 RSI	632 RSI	
KX 125	95 - 08	694 RSI	604 RSI	
Z 125	19 - 19	638 HF	638 HF	
Z 125 Pro	17 - 18	925 HF	536 HF	
Z 125 Pro KRT Ed.	18 - 18	925 HF	536 HF	
Z 125 Pro KRT SE	18 - 18	925 HF	536 HF	
KLX 140 , L	08 - 21	611 SI	592 SI	
KLX 150 D-Tracker	16 - 18	611 HF	536 HF	
KLX 150 L	14 - 15	611 HF	536 HF	
KLT 160	85 - 85	2015	2183	
KDX 175	80 - 82	2039	2183	
KE 175	76 - 78	2039	2183	
KE 175	79 - 83	2039	2056	
KLF 185 Bayou	85 - 85		2038	
KLF 185 Bayou	86 - 88	2040*	2038	
KLT 185	86 - 87	2015	2183	
KDX 200	83 - 85	2056	2025	
KDX 200	93 - 93	611 SI	632 SI	
KDX 200	94 - 99	694 SI	632 SI	
KDX 200 C	86 - 88	546 SI	2025	
KDX 200 SR	89 - 92	546 SI	632 SI	
KLT 200	81 - 84	2015	2040	
KZ 200	78 - 79	516 HF	2014	
KDX 220 R	97 - 05	694 SI	632 SI	
KLF 220 Bayou	88 - 02	2040*	2038	
KLX 230	19 - 22	611 HF	536 HF	
KLX 230 R	22 - 22	611 HF	536 HF	
KLX 230 SE	22 - 22	611 HF	536 HF	
EL 250	91 - 94	557 HF	2038	
EL 250 Eliminator	88 - 89	557 HF	2038	
EX 250 R Ninja	86 - 87	557 HF	557 HF	
EX 250 R Ninja	88 - 07	597 HF	615 HF	
EX 250 R Ninja	08 - 17	638 HS	638 LS	
EX 250 R Ninja	18 - 20	955 HS	638 LS	
EX 250 SL Ninja	15 - 17	638 HS	638 LS	
KDX 250	80 - 82	2040	2016	
KDX 250	83 - 84	2040	2183	
KDX 250 SR	91 - 94	611 SI	632 SI	
KH 250	76 - 80	510 HF	2088	
KL 250	78 - 79	2040	2016	
KL 250	80 - 84	2039	2056	
KL 250 (KLR 250)	85 - 97	546 HF	2056	
KL 250 Super Sherpa	00 - 02	726 SI	586 SI	
KLF 250 Bayou	03 - 11	2040*	2038	
KLR 250	84 - 05	546 HF	2038	

\* = 2 sets required / 2 jeux pour l'Avant.

Full compound selection, see under "Brake pad 1:1 Drawings" / Sélection complète de composés, voir "1:1 Schémas Plaquettes de frein".

**RECOMMENDED**1xx - 2xx = Scooter Pads  
5xx - 9xx = Street, Off Road & Racing Pads  
2xxx = Brake Shoes

KAWASAKI					
KLT	250	82 - 83	2015	2040	
KLT	250 Police	84 - 84	2015	2040	
KLT	250 Prairie	83 - 85	2015	2040	
KLX	250	79 - 80	2039	2183	
KLX	250	93 - 96	694 SI	632 SI	
KLX	250	98 - 07	694 SI	604 SI	
KLX	250	14 - 18	611 HF	604 HF	
KLX	250 Camo	18 - 18	611 HF	604 HF	
KLX	250 S	09 - 14	611 HF	604 HF	
KLX	250 SF	09 - 10	611 HF	604 HF	
KSF	250 Mojave	87 - 02	591 SI*	592 SI	
KT	250 all models	75 - 80	2039	2183	
KX	250	75 - 81	2040	2016	
KX	250	82 - 82	544 SI	2183	
KX	250	83 - 85	546 SI	2183	
KX	250	86 - 86	546 RSI	586 RSI	
KX	250	87 - 88	602 HF	586 SI	
KX	250	89 - 93	611 RSI	632 RSI	
KX	250	94 - 94	694 RSI	632 RSI	
KX	250	95 - 08	694 RSI	604 RSI	
KX	250	19 - 22	694 RSI	790 RSI	
KX	250 F	04 - 18	694 RSI	790 RSI	
KX	250 X	21 - 22	694 SI	790 SI	
KXF	250 Tecate	87 - 88	591 SI*	592 SI	
KXT	250 Tecate	84 - 84		544 HF	
KXT	250 Tecate	85 - 86	546 SI	586 SI	
KXT	250 Tecate	87 - 88	591 SI	592 SI	
KZ	250	80 - 83	2016	2014	
SC	250 Epsilon	02 - 06	146 MS*	174 MS	
Z	250 SL	15 - 17	638 HF	638 HF	
ZX-25R	250	20 - 20	806 HS	657 LS	
EX	300 R Ninja, ABS	13 - 17	638 HS	638 LS	
J	300	14 - 19	183 MS	204 MS	
KAF	300 Mule 500	92 - 95	2053*		
KAF	300 Mule 550	03 - 05	2053*		
KEF	300 Lakota	95 - 04	591 SI*	592 SI	
KLE	300 Versys-X	17 - 20	627 HS	638 LS	
KLF	300 Bayou	86 - 87	2054*	2038*	
KLF	300 Bayou	88 - 04	546 SI*	2038*	
KLF	300 Bayou 4x4 Left	89 - 05	611 SI	2197	
KLF	300 Bayou 4x4 Right	89 - 05	638 SI		
KLX	300 R	97 - 07	694 SI	604 SI	
KVF	300 Brute Force	13 - 17	810 SI*	810 SI	
KVF	300 Prairie	99 - 02	536 SI*		
KVF	300 Prairie 4x4	99 - 05	536 SI*		
Z	300	15 - 16	638 HS	638 LS	
EX	305	83 - 83	557 HF	2038	
KZ	305	81 - 88	540 HF	2038	
S2A	350	73 - 73	503 HF	2088	
KVF	360 Prairie 2x4, 4x4	03 - 08	536 SI*		
	400 Ninja R Left	11 - 11	705 HS	687 LS	
	400 Ninja R Right	11 - 11	704 HS		
EX	400 Ninja	18 - 22	955 HS*	638 LS	
EX	400 Ninja KRT	18 - 18	638 HS*	638 LS	
EX	400 Ninja SE	18 - 19	955 HS*	638 LS	
KFX	400	02 - 05	592 SI*	649 SI	
KH	400	76 - 78	510 HF	2088	
KLF	400 Bayou Left	93 - 99	611 SI	2197	
KLF	400 Bayou Right	93 - 99	638 SI		
KLX	400 R	03 - 04	694 SI	604 SI	
KLX	400 SR	03 - 04	694 HF	604 HF	
KVF	400 Prairie	97 - 98	536 SI*	2197	
KVF	400 Prairie 2x4	99 - 01	536 SI*		
KVF	400 Prairie 4x4	99 - 02	536 SI*		
KZ	400	74 - 77	510 HF	2088	
KZ	400	78 - 79	522 HF	2038	
KZ	400 H1 (LTD)	79 - 79	510 HF	2038	
ZR	400 Zephyr	97 - 01	631 HS*	687 LS	

**RECOMMENDED**1xx - 2xx = Scooter Pads  
5xx - 9xx = Street, Off Road & Racing Pads  
2xxx = Brake Shoes

KAWASAKI					
KX	420	80 - 81	2040	2016	
KZ	440	80 - 82	510 HF	2038	
KZ	440	83 - 83	540 HF	2038	
KZ	440 , LTD	83 - 85	540 HF	2038	
KZ	440 C	80 - 81	510 HF	2038	
KZ	440 C, Twin	81 - 83	540 HF	2038	
KZ	440 H	82 - 84	539 HF	540 HF	
KZ	440 LTD	80 - 82	510 HF	2038	
EN	450	85 - 90	557 HF	2060	
KFX	450 Left	07 - 15	801 SI	592 SI	
KFX	450 Right	07 - 15	798 SI		
KLX	450 R	07 - 19	694 SI	790 SI	
KX	450	19 - 22	694 RSI	790 RSI	
KX	450 F	06 - 18	694 RSI	790 RSI	
KX	450 X	21 - 22	694 SI	790 SI	
EN	500	90 - 04	557 HS	2060	
EN	500 Vulcan	96 - 97	557 HS	2060	
EX	500	87 - 89	597 HF	2038	
EX	500	90 - 93	597 HS	2038	
EX	500	94 - 96	615 HS	586 LS	
EX	500 Ninja	94 - 97	597 HS	586 LS	
KH	500	76 - 79	510 HF		
KH	500 H1	74 - 75	503 HF		
KX	500	83 - 85	546 SI	2183	
KX	500	86 - 86	546 RSI	586 RSI	
KX	500	87 - 88	602 HF	586 SI	
KX	500	89 - 93	611 RSI	632 RSI	
KX	500	94 - 95	694 RSI	632 RSI	
KX	500	96 - 04	694 RSI	604 RSI	
GPZ	550	84 - 87	557 HF*	557 HF	
KZ	550	81 - 83	540 HF*	540 HF	
KZ	550 A1	80 - 80	510 HF	2060	
ZR	550 A1, GP	83 - 84	546 HF*	2038	
ZR	550 Zephyr	90 - 92	597 HS*	615 LS	
ZR	550 Zephyr	93 - 99	597 HS*	687 LS	
ZX	550	84 - 89	557 HF*	557 HF	
	600 R, Ninja	89 - 96	631 HF*	556 HF	
KL	600	84 - 86	546 HF	2183	
KLR	600	84 - 86	546 HF	2183	
KLR	600 E	85 - 94	546 HF	2183	
ZL	600	85 - 91	557 HF	2060	
ZL	600 B2 Eliminator	95 - 98	597 HS	2060	
ZX	600 Ninja	85 - 87	557 HF*	557 HF	
ZX	600 Ninja	90 - 93	631 HS*	597 LS	
ZX	600 Ninja R	88 - 97	597 HS*	597 LS	
ZX-6R	600 (Ninja ZX6)	93 - 97	631 HS*	687 LS	
ZX-6R	600 (Ninja ZX6R)	95 - 97	631 HS*	687 LS	
ZX-6R	600 (ZX6)	90 - 93	631 HS*	597 LS	
ZX-6R	600 Ninja	98 - 01	686 HS*	687 LS	
ZX-6R	600 Ninja	07 - 17	838 HS*	687 LS	
ZX-6RR	600 Ninja	03 - 06	788 HS*	687 LS	
ZX-6R	636 Ninja	02 - 02	686 HS*	687 LS	
ZX-6R	636 Ninja	03 - 06	788 HS*	687 LS	
ZX-6R	636 Ninja	13 - 18	894 HS*	834 LS	
ZX-6R	636 Ninja KRT ABS	13 - 18	894 HS*	834 LS	
ZX-6R	636 Ninja Upgrade DS	13 - 22	860 SP*	834 LS	
	650 R Ninja Left	06 - 08	705 HS	687 LS	
	650 R Ninja Right	06 - 08	704 HS		
EN	650 Vulcan S	15 - 19	735 HS	657 LS	
EN	650 Vulcan S Cafe	17 - 19	735 HS	657 LS	
EN	650 Vulcan S SE	17 - 18	735 HS	657 LS	
EX	650 Ninja KRT ABS	17 - 20	627 HS	657 LS	
EX	650 Ninja Performance ABS	17 - 20	627 HS*	657 LS	
EX	650 Ninja Tourer ABS	17 - 20	627 HS*	657 LS	
KLE	650 Versys Left	07 - 14	705 HS	687 LS	
KLE	650 Versys Right	07 - 14	704 HS		
KLE	650 Versys	15 - 15	627 HS*	881 LS	
KLE	650 Versys	16 - 21	627 HS*	657 LS	

\* = 2 sets required / 2 jeux pour l'Avant.



**RECOMMENDED**

1xx - 2xx = Scooter Pads  
 5xx - 9xx = Street, Off Road & Racing Pads  
 2xxx = Brake Shoes



KAWASAKI				
KLE	650 Versys LT	15 - 16	627 HS*	881 LS
KLR	650	87 - 94	602 HF	586 SI
KLR	650	95 - 04	705 HS	586 LS
KLR	650	08 - 18	611 HS	638 LS
KLR	650 Camo	08 - 18	611 HS	638 LS
KLR	650 Tengai	89 - 92	597 HS	586 LS
KLX	650	93 - 96	694 SI	632 SI
KLX	650 R	93 - 95	694 SI	632 SI
KLX	650 R D1	96 - 96	694 SI	604 SI
KVF	650 Brute Force 4x4 Left	05 - 11	801 SI	
KVF	650 Brute Force 4x4 Right	05 - 11	798 SI	
KVF	650 Brute Force 4x4i Left	05 - 11	611 SI	
KVF	650 Brute Force 4x4i Right	05 - 11	638 SI	
KVF	650 Prairie Left	01 - 03	801 SI	
KVF	650 Prairie Right	01 - 03	798 SI	
KZ	650	78 - 82	510 HF*	512 HF
KZ	650	81 - 84	539 HF	2060
KZ	650 , CSR	81 - 82	540 HF	
KZ	650 C	78 - 79	510 HF*	514 HF
KZ	650 F	81 - 84	539 HF*	2060
W	650	99 - 05	704 HF	2038
Z	650 ABS	17 - 19	627 HS*	657 LS
KFX	700 V-Force Left	04 - 13	801 SI	
KFX	700 V-Force Right	04 - 13	798 SI	
KSV	700 V-Force Left	04 - 11	801 SI	
KSV	700 V-Force Right	04 - 11	798 SI	
KVF	700 Prairie Left	04 - 13	801 SI	
KVF	700 Prairie Right	04 - 13	798 SI	
KZ	700	83 - 88	539 HF*	540 HF
VN	700 Vulcan	85 - 85	557 HF*	2060
ZN	700	84 - 89	557 HF*	557 HF
	750 Vulcan	93 - 94	557 HF	2060
GPZ	750	82 - 82	539 HF	540 HF
GPZ	750	83 - 87	557 HF*	557 HF
GPZ	750 R	85 - 86	557 HF*	557 HF
GPZ	750 T	83 - 85	557 HF*	557 HF
KRF	750 Teryx 4x4 Left	08 - 13	611 SI	
KRF	750 Teryx 4x4 Left	08 - 13	638 SI	
KVF	750 Brute Force 4x4i Left	05 - 15	611 SI	
KVF	750 Brute Force 4x4i Right	05 - 15	638 SI	
KZ	750	83 - 84	557 HF*	2060
KZ	750	84 - 86	539 HF*	540 HF
KZ	750 , LTD	80 - 81	539 HF*	540 HF
KZ	750 , Turbo	84 - 86	557 HF*	557 HF
KZ	750 B	76 - 79	510 HF	514 HF
KZ	750 E	80 - 81	539 HF*	540 HF
KZ	750 Eliminator	88 - 88	557 HF*	557 HF
KZ	750 GT	82 - 85	539 HF*	540 HF
KZ	750 H	72 - 75	503 HF	2091
KZ	750 L	80 - 82	539 HF*	540 HF
KZ	750 L	84 - 86	540 HF*	540 HF
KZ	750 L3	83 - 83	540 HF*	540 HF
KZ	750 LTD	80 - 81	510 HF*	2060
KZ	750 LTD Belt Drive	83 - 85	539 HF*	540 HF
KZ	750 LTD Twin	82 - 82	539 HF*	540 HF
KZ	750 LTD Twin	83 - 85	557 HF	557 HF
KZ	750 M1	82 - 85	540 HF	2060
KZ	750 R1	82 - 82	540 HF*	540 HF
KZ	750 Sp.	83 - 84	539 HF*	540 HF
KZ	750 Y1, N, LTD	82 - 85	539 HF*	540 HF
VN	750 Twin	88 - 88	557 HS*	
VN	750 Vulcan	86 - 94	557 HF*	2060
Z	750	83 - 83	557 HF*	2060
Z	750	84 - 86		540 HF
Z	750 Left	04 - 06	705 HS	687 LS
Z	750 Right	04 - 06	704 HS	
Z	750 , ABS	07 - 12	627 HS*	657 LS
Z	750 R	11 - 12	838 HS*	881 LS



**RECOMMENDED**

1xx - 2xx = Scooter Pads  
 5xx - 9xx = Street, Off Road & Racing Pads  
 2xxx = Brake Shoes



KAWASAKI				
Z	750 S Left	05 - 06	705 HS	687 LS
Z	750 S Right	05 - 06	704 HS	
ZR	750 Zephyr	91 - 95	597 HS*	597 LS
ZR	750 Zephyr Left	96 - 97	705 HS	597 LS
ZR	750 Zephyr Right	96 - 97	704 HS	
ZR-7S	750 Left	01 - 04	705 HS	704 LS
ZR-7S	750 Right	01 - 04	704 HS	
ZX	750 E, GP	83 - 85	557 HF*	557 HF
ZX-7R	750 Ninja	89 - 95	631 HS*	556 LS
ZX-7R	750 Ninja	96 - 03	686 HS*	556 LS
ZX-7RR	750 Ninja	96 - 02	676 HS*	715 LS
	800 Mule Pro FX Left	15 - 17	611 SI	
	800 Mule Pro FX Right	15 - 17	638 SI	
KRF	800 Teryx BEF/CEF/DEF Left	14 - 17	611 SI	
KRF	800 Teryx BEF/CEF/DEF Right	14 - 17	638 SI	
KRT	800 Teryx 4 BEF/CEF/DEF Left	14 - 17	611 SI	
KRT	800 Teryx 4 BEF/CEF/DEF Right	14 - 17	638 SI	
VN	800 Vulcan Classic	96 - 06	705 HS	2060
VN	800 Vulcan Drifter	99 - 03	705 HS	704 LS
VN	800 Vulcan, Classic	95 - 97	557 HS	2060
W	800	11 - 16	704 HS	
W	800 Cafe	19 - 19	704 HS	
W	800 Street	19 - 19	704 HS	
Z	800	13 - 16	782 HS*	881 LS
Z	800 ABS	13 - 16	782 HS*	881 LS
Z	800 e	13 - 16	627 HS*	881 LS
Z	800 e ABS	13 - 16	782 HS*	881 LS
KZ	900	76 - 76	510 HF*	514 HF
KZ	900	76 - 77	510 HF	2091
KZ	900 A	76 - 77	510 HF*	2091
VN	900 Vulcan Classic	06 - 16	705 HS	886 LS
VN	900 Vulcan Classic SE	11 - 16	705 HS	886 LS
VN	900 Vulcan Custom	07 - 16	705 HS	886 LS
Z	900	17 - 21	782 HS*	881 LS
Z	900 Performance	22 - 22	782 SP*	881 LS
Z	900 RS	18 - 21	806 HS*	657 LS
Z	900 RS Cafe	18 - 21	806 HS*	657 LS
ZL	900 Eliminator	85 - 86	557 HF*	557 HF
ZX	900	83 - 84	557 HF*	557 HF
ZX-9R	900 Ninja	94 - 95	631 HS*	687 LS
ZX-9R	900 Ninja	96 - 01	686 HS*	687 LS
ZX-9R	900 Ninja	02 - 03	782 HS*	687 LS
	1000 Ninja sx	20 - 20	806 SP*	687 LS
KLE	1000 Versys	12 - 18	631 SP*	657 LS
KLE	1000 Versys ABS	15 - 18	631 SP*	657 LS
KLE	1000 Versys ABS	19 - 20	806 SP*	657 LS
KLE	1000 Versys LT	15 - 16	631 SP*	657 LS
KLE	1000 Versys SE	19 - 20	806 SP*	657 LS
KLV	1000 Left	04 - 07	705 HS	657 LS
KLV	1000 Right	04 - 07	704 HS	
KZ	1000	76 - 81	510 HF*	512 HF
KZ	1000	87 - 01	539 HF*	540 HF
KZ	1000 F1	80 - 82	539 HF*	512 HF
KZ	1000 GL	80 - 82	510 HF*	512 HF
KZ	1000 H1	80 - 83	510 HF*	512 HF
KZ	1000 J	79 - 83	539 HF*	540 HF
KZ	1000 K, M, CSR	81 - 84	539 HF*	540 HF
KZ	1000 LTD	81 - 84	539 HF*	540 HF
KZ	1000 MKII	79 - 80	539 HF*	512 HF
KZ	1000 Police	82 - 01	539 HF	540 HF
KZ	1000 Police Left	02 - 03	705 HS	886 LS
KZ	1000 Police Right	02 - 03	704 HS	
KZ	1000 R Ninja	86 - 88	557 HF*	557 HF
KZ	1000 RE1, R2	82 - 84	540 HF*	540 HF

\* = 2 sets required / 2 jeux pour l'Avant.

Full compound selection, see under "Brake pad 1:1 Drawings" / Sélection complète de composés, voir "1:1 Schémas Plaquettes de frein".

**RECOMMENDED**1xx - 2xx = Scooter Pads  
5xx - 9xx = Street, Off Road & Racing Pads  
2xxx = Brake Shoes

KAWASAKI					
KZ	1000 ST	79 - 81	539 HF*	512 HF	
Z	1000 ABS	15 - 19	806 HS*	687 LS	
Z	1000 H2	20 - 21	900 SP*	657 LS	
Z	1000 H2 SE	21 - 21	841 SP*	657 LS	
Z	1000 Ninja	14 - 16	806 HS*	687 LS	
Z	1000 SE	14 - 16	806 HS*	687 LS	
Z	1000 SX	11 - 19	806 HS*	687 LS	
ZG	1000 Concours	86 - 93	557 HF*	557 HF	
ZG	1000 Concours	94 - 03	597 HS*	557 LS	
ZL	1000	86 - 87	557 HF*	557 HF	
ZX	1000 H2 Carbon Ninja	17 - 20	841 SP*	730 LS	
ZX	1000 H2 Ninja	15 - 21	841 SP*	730 LS	
ZX	1000 H2 SX	18 - 19	806 HS*	611 LS	
ZX	1000 H2 SX SE	18 - 19	806 HS*	611 LS	
ZX	1000 H2 SX SE+	19 - 21	841 SP*	611 LS	
ZX	1000 H2R Ninja	15 - 20	841 SP*	730 LS	
ZX-10	1000	88 - 90	597 HS*	597 LS	
ZX-10R	1000 Ninja	04 - 07	788 HS*	687 LS	
ZX-10R	1000 Ninja	08 - 10	806 SP*	687 LS	
ZX-10R	1000 Ninja	11 - 15	806 SP*	834 LS	
ZX-10R	1000 Ninja	16 - 22	841 SP*	834 LS	
ZX-10R	1000 Ninja ABS	12 - 15	806 SP*	834 LS	
ZX-10R	1000 Ninja KRT	16 - 18	841 SP*	834 LS	
ZX-10R	1000 Ninja SE	18 - 22	841 SP*	834 LS	
ZX-10RR	1000 Ninja	17 - 22	841 SP*	834 LS	
GPZ	1100	81 - 82	539 HF*	540 HF	
GPZ	1100	83 - 86	557 HF*	557 HF	
GPZ	1100 (ZX 1100) Left	95 - 99	705 HS	687 LS	
GPZ	1100 (ZX 1100) Right	95 - 99	704 HS		
KZ	1100 , Spectre	82 - 83	539 HF*	540 HF	
KZ	1100 GP	81 - 81	539 HF	540 HF	
KZ	1100 GP	83 - 86	557 HF*	557 HF	
KZ	1100 L1, LTD	83 - 83	539 HF*	540 HF	
KZ	1100 R, LTD	84 - 84	557 HF*	557 HF	
ZN	1100 LTD	84 - 84	557 HF*	557 HF	
ZR	1100 Zephyr	92 - 95	631 HS*	597 LS	
ZRX	1100	96 - 00	686 HS*	556 LS	
ZX	1100	93 - 97	631 HS*	556 LS	
ZX	1100 GP	83 - 83	557 HF*	557 HF	
ZZR	1100	90 - 93	631 HS*	597 LS	
ZZR	1100	94 - 01	631 HS*	556 LS	
ZG	1200 Voyager XII	86 - 93	557 HS*	557 LS	
ZRX	1200	01 - 04	686 HS*	556 LS	
ZRX	1200 R	01 - 08	686 HS*	556 LS	
ZRX	1200 S	01 - 07	686 HS*	556 LS	
ZX-12R	1200 Ninja	00 - 03	686 HS*	556 LS	
ZX-12R	1200 Ninja	04 - 06	788 HS*	556 LS	
ZZR	1200	02 - 04	631 HS*	556 LS	
KZ	1300	79 - 81	530 HF*	512 HF	
ZN	1300	83 - 84	557 HF*	557 HF	
ZN	1300 Voy.	85 - 86	557 HF*	557 HF	
ZG	1400 Concours	07 - 10	838 HS*	715 LS	
ZX-14R	1400 Ninja	06 - 15	838 HS*	715 LS	
ZX-14R	1400 Ninja ABS	07 - 15	838 HS*	715 LS	
ZX-14R	1400 SE	16 - 18	841 HS*	715 LS	
VN	1500 Mean Streak	02 - 03	686 HS	886 LS	
VN	1500 Vulcan	87 - 92	557 HS	557 LS	
VN	1500 Vulcan Classic	97 - 99	705 HS	557 LS	
VN	1500 Vulcan Classic Fi	00 - 04	705 HS	886 LS	
VN	1500 Vulcan Drifter	99 - 02	705 HS	704 LS	
VN	1500 Vulcan Nomad Left	98 - 01	705 HS	557 LS	
VN	1500 Vulcan Nomad Right	98 - 01	704 HS		
VN	1500 Vulcan Nomad Fi Left	00 - 04	705 HS	886 LS	
VN	1500 Vulcan Nomad Fi Right	00 - 04	704 HS		
VN	1500 Vulcan, SE	87 - 92	557 HS	557 LS	
VN	1600 Mean Streak	04 - 04	686 HS*	886 LS	
VN	1600 Mean Streak	05 - 05	788 HS*	886 LS	
VN	1600 Nomad Left	05 - 05	705 HS	886 LS	

**RECOMMENDED**1xx - 2xx = Scooter Pads  
5xx - 9xx = Street, Off Road & Racing Pads  
2xxx = Brake Shoes

KAWASAKI					
VN	1600 Nomad Right	05 - 05	704 HS		
VN	1600 Vulcan Classic Left	03 - 08	705 HS	886 LS	
VN	1600 Vulcan Classic Right	03 - 08	704 HS		
VN	1700 Voyager Vaquero Left	09 - 14	705 HS	886 LS	
VN	1700 Voyager Vaquero Right	09 - 14	704 HS		
VN	1700 Vulcan Classic Left	09 - 14	705 HS	886 LS	
VN	1700 Vulcan Classic Right	09 - 14	704 HS		
VN	1700 Vulcan Nomad Left	09 - 16	705 HS	886 LS	
VN	1700 Vulcan Nomad Right	09 - 16	704 HS		
VN	1700 Vulcan Voyager	09 - 16	631 HS*	886 LS	
VN	2000 Vulcan	04 - 10	631 HS*	886 LS	

KEEWAY					
	50 Flash	07 - 12	101 HF	2028	
	50 Flash Electric	10 - 12	141 HF	2028	
	50 Focus	06 - 15	141 HF		
	50 Hurricane	06 - 16	101 HF	2028	
	50 Matrix	06 - 15	141 HF	2028	
	50 Matrix Electric	10 - 15	141 HF		
	50 Matrix Racing Sport	10 - 16	141 HF		
F-NKD	50	10 - 11	141 HF	2028	
RY8	50	07 - 09	141 HF	2028	
RY8	50	10 - 16	141 HF	200 HF	
TX	50 SM	10 - 12	173 HF		
	90 Hurricane	06 - 09	101 HF		
	100 Partner	06 - 10	119 HF		
	110 Partner	06 - 07	119 HF		
	125 Arn	06 - 08	123 CT		
	125 Cityblade	17 - 19	232 HF	152 HF	
	125 Enduro	07 - 08	774 HF	519 HF	
	125 Focus	06 - 08	141 CT		
	125 Logik	17 - 19	232 HF		
	125 Matrix	06 - 08	141 CT		
	125 Matrix Racing Sport	10 - 16	141 CT		
	125 Speed	06 - 12	132 CT	119 CT	
	125 Superlight	06 - 16	713 HF		
	125 Superlight	17 - 19	961 HF		
	125 X-Ray	07 - 08	774 HF	519 HF	
TX	125 SM	10 - 16	780 HF		
	150 Arn	06 - 08	123 CT		
	150 Focus	06 - 09	141 CT		
	150 Matrix	06 - 08	141 CT		
	150 Matrix Racing Sport	10 - 12	141 CT		
	150 Speed	06 - 09	132 CT	119 CT	
	150 Superlight	06 - 16	713 HF		
	250 Land Cruiser	06 - 14	713 HF		
	250 Supershadow	06 - 09	691 HF		

KTM					
	Freeride Electric	12 - 14	885 RSI	872 RSI	
E-SM	Freeride	15 - 16	885 RSI	872 RSI	
E-SX	Freeride	15 - 16	885 RSI	872 RSI	
E-XC	Freeride	15 - 22	885 RSI	872 RSI	
SX-E	5	19 - 22	794 RSI	794 RSI	
SM	50 Supermoto	06 - 06	794 RSI	794 RSI	
SX	50	09 - 22	794 RSI	794 RSI	
SX	50 Adventure	98 - 03	2074	2074	
SX	50 Mini	09 - 22	794 RSI	794 RSI	
SX	50 Pro Junior LC	02 - 05	794 RSI	2074	
SX	50 Pro Senior LC	02 - 03	794 RSI	2074	
SX	50 Pro Senior LC	04 - 09	794 RSI	794 RSI	
SX	50 Senior Adventure	04 - 07	794 RSI	2074	
SX	60	99 - 99	559 RSI		
SX	65	00 - 01	559 RSI	574 RSI	
SX	65	02 - 03	783 RSI	574 RSI	
SX	65	04 - 08	783 RSI	794 RSI	
SX	65	09 - 22	783 RSI	783 RSI	
SX	85	04 - 10	783 RSI	783 RSI	

\* = 2 sets required / 2 jeux pour l'Avant.



**RECOMMENDED**

1xx - 2xx = Scooter Pads  
 5xx - 9xx = Street, Off Road & Racing Pads  
 2xxx = Brake Shoes



KTM				
SX	85	11 - 11	783 RSI	872 RSI
SX	85	12 - 20	885 RSI	872 RSI
SX	85	21 - 22	671 RSI	791 RSI
SX	85 (19"/16" wheels)	13 - 20	885 RSI	872 RSI
SX	85 (19"/16" wheels)	21 - 22	671 RSI	791 RSI
	125	83 - 83	2120	2120
	125 Duke	11 - 19	877 HS	675 LS
	125 Sting	99 - 99	566 HF	675 HF
	125 SuperMoto	00 - 03	671 HF	675 HF
EXC	125	90 - 90	621 HF	621 HF
EXC	125 Enduro	99 - 03	671 SI	675 SI
EXC	125 Enduro	04 - 15	671 SI	791 SI
EXE	125	00 - 00	671 HF	675 HF
GS	125	83 - 83	2122	2120
GS	125	84 - 85	2122	2122
GS	125	88 - 88	621 HF	621 HF
GS	125	89 - 90	546 SI	586 SI
GS	125	92 - 97	671 SI	586 SI
LC	125	85 - 85	519 SI	
LC	125	86 - 86	519 SI	519 SI
LC2	125	99 - 99	671 HF	675 HF
LL	125	83 - 83	2122	2120
MX	125	84 - 84	2122	2122
MX	125	85 - 85	519 SI	2122
MX	125	86 - 86	519 SI	519 SI
MX	125	88 - 88	621 HF	621 HF
MX	125	89 - 90	546 SI	692 SI
MX	125	92 - 93	671 SI	692 SI
RC	125	14 - 22	877 HS	675 LS
SX	125	96 - 03	671 RSI	675 RSI
SX	125	04 - 22	671 RSI	791 RSI
XC	125	85 - 85	519 SI	2122
XC	125	86 - 89	519 SI	519 SI
XC	125	19 - 22	671 RSI	791 RSI
SX	144	07 - 08	671 RSI	791 RSI
EXC	150 TPI	20 - 22	671 SI	791 SI
SX	150	09 - 22	671 RSI	791 RSI
XC	150	10 - 19	671 RSI	791 RSI
XC	150 TPI	20 - 22	671 RSI	791 RSI
	175	79 - 82	2120	2121
	200 Duke	12 - 17	877 HS	675 LS
EXC	200 Enduro	99 - 03	671 SI	675 SI
EXC	200 Enduro	04 - 16	671 SI	791 SI
RC	200	14 - 22	877 HS	675 LS
SX	200	03 - 04	671 RSI	791 RSI
XC	200	06 - 09	671 RSI	791 RSI
XC-W	200	06 - 16	671 RSI	791 RSI
	250 Baja	86 - 89	519 SI	2122
	250 Country,Baja	85 - 85	519 SI	2122
	250 Cross	80 - 81	2120	2120
	250 Cross	82 - 82	2121	2121
	250 Cross	83 - 83	2118	2121
	250 Duke	14 - 15	877 HS	675 LS
	250 Freeride R	14 - 19	885 RSI	872 RSI
	250 GS,EXC,			
	Enduro Models	91 - 91	621 HF	586 SI
EXC	250	90 - 90	621 HF	621 HF
EXC	250 Enduro	99 - 03	671 SI	675 SI
EXC	250 Enduro	04 - 08	671 SI	791 SI
EXC	250 Enduro 4T	99 - 03	671 SI	675 SI
EXC	250 Enduro 4T	04 - 06	671 SI	791 SI
EXC	250 TPI	18 - 22	671 SI	791 SI
EXC-F	250	07 - 22	671 SI	791 SI
GS	250	83 - 85	2122	2122
GS	250	88 - 88	621 HF	621 HF
GS	250	89 - 90	546 SI	586 SI
LC	250	85 - 85	519 SI	
LC	250	86 - 86	519 SI	519 SI



**RECOMMENDED**

1xx - 2xx = Scooter Pads  
 5xx - 9xx = Street, Off Road & Racing Pads  
 2xxx = Brake Shoes



KTM				
MC	250	83 - 84	519 SI	519 SI
MX	250	84 - 84	2122	2122
MX	250	85 - 85	519 SI	2122
MX	250	88 - 88	621 HF	621 HF
MX	250	89 - 90	546 SI	692 SI
MX	250	92 - 93	671 SI	692 SI
MX	250 VC, Enduro	87 - 90	601 HF	601 HF
RC	250	14 - 15	877 HS	675 LS
RC	250 Upgrade DS	14 - 15	634 RST	675 LS
SX	250	96 - 02	671 RSI	675 RSI
SX	250	03 - 22	671 RSI	791 RSI
SX-F	250	06 - 22	671 RSI	791 RSI
XC	250	85 - 85	519 SI	
XC	250	86 - 89	519 SI	519 SI
XC	250	06 - 14	671 RSI	791 RSI
XC	250 TPI	19 - 22	671 RSI	791 RSI
XC-F	250	10 - 22	671 RSI	791 RSI
XC-W	250	08 - 17	671 RSI	791 RSI
EXC	300	90 - 90	621 HF	621 HF
EXC	300	93 - 96	671 SI	586 SI
EXC	300 Enduro	99 - 03	671 SI	675 SI
EXC	300 Enduro	04 - 08	671 SI	791 SI
EXC	300 TPI	18 - 22	671 SI	791 SI
GS	300	85 - 85	2122	2122
MX	300	85 - 89		2122
MX	300	90 - 90	546 SI	586 SI
MX	300	92 - 92	671 SI	586 SI
XC	300	85 - 85	519 SI	2122
XC	300	86 - 90	519 SI	519 SI
XC	300	06 - 14	671 RSI	791 RSI
XC	300 (Drum vers.)	85 - 85	2122	2122
XC	300 TPI	19 - 22	671 RSI	791 RSI
XC-W	300	06 - 08	671 RSI	791 RSI
	350 Country Cross	85 - 85	519 SI	2122
	350 Freeride	12 - 17	885 RSI	872 RSI
	350 GS	83 - 85	519 SI	2121
	350 GS (Drum vers.)	83 - 85	2122	2122
EXC	350	87 - 87	601 HF	601 HF
EXC	350	88 - 90	621 HF	621 HF
EXC-F	350	11 - 22	671 SI	791 SI
GS	350	87 - 87	601 HF	601 HF
GS	350	88 - 92	621 HF	621 HF
GS4	350 500 K4	82 - 83	519 SI	
K4	350 500 K4	82 - 83	519 SI	
LC4	350	92 - 95	546 SI	586 SI
MX	350	87 - 87	601 HF	601 HF
MX	350	88 - 88	621 HF	621 HF
SX-F	350	11 - 22	671 RSI	791 RSI
XC	350 , MC	81 - 83	519 SI	
XC-F	350	12 - 22	671 RSI	791 RSI
XCF-W	350	13 - 17	671 RSI	791 RSI
MX	360	96 - 97	671 SI	675 SI
SX	360	96 - 97	671 RSI	675 RSI
XC	360	96 - 97	671 SI	675 SI
EXC	380 Enduro	99 - 99	671 SI	675 SI
MX	380	98 - 98	671 SI	675 SI
SX	380	98 - 02	671 RSI	675 RSI
XC	380	98 - 03	671 SI	675 SI
	390 Adventure	20 - 20	877 HS	675 LS
	390 Duke	13 - 20	877 HS	675 LS
	390 GS	83 - 83	519 SI	2121
	390 GS (Drum vers.)	83 - 83	2122	2122
RC	390	14 - 22	877 HS	675 LS
RC	390 Upgrade DS	14 - 22	634 RST	675 LS
XC	390 , MC	81 - 83	519 SI	
	400 Enduro	87 - 90	601 HF	601 HF
EXC	400 Racing	00 - 03	671 SI	675 SI
EXC	400 Racing	04 - 07	671 SI	791 SI

\* = 2 sets required / 2 jeux pour l'Avant.

Full compound selection, see under "Brake pad 1:1 Drawings" / Sélection complète de composés, voir "1:1 Schémas Plaquettes de frein".

**RECOMMENDED**1xx - 2xx = Scooter Pads  
5xx - 9xx = Street, Off Road & Racing Pads  
2xxx = Brake Shoes

			<b>RECOMMENDED</b>	
<b>KTM</b>				
LC4	400	93 - 02	671 SI	586 SI
LC4-E	400 Enduro	99 - 02	671 SI	675 SI
SC	400	99 - 00	671 SI	675 SI
SX	400 Racing	00 - 02	671 RSI	675 RSI
SXC	400 Tiainen Replica	99 - 00	671 SI	675 SI
XC-W	400	07 - 10	671 RSI	791 RSI
GS	420	84 - 87	2122	2122
XC	420 , MC	81 - 83	519 SI	
	450 Rally	11 - 17	674 SI	675 SI
	450 Rally	19 - 22	674 SI	791 SI
EXC-F	450	04 - 22	671 SI	791 SI
SX	450 ATV	08 - 10	866 RSI*	867 RSI
SX	450 SM Factory Replica	04 - 07	566 RSI	791 RSI
SX	450 SMR	04 - 06	842 RSI	791 RSI
SX	450 SMR	07 - 12	843 RSI	791 RSI
SX	450 SMR	13 - 15	841 RST	791 RSI
SX	450 SMR	21 - 22	841 RST	791 RSI
SX-F	450	03 - 22	671 RSI	791 RSI
XC	450 ATV	08 - 10	866 SI*	867 SI
XC-F	450	06 - 22	671 RSI	791 RSI
XCF-W	450	07 - 15	671 RSI	791 RSI
MC	495 Leleu	82 - 83	519 SI	2121
MX	495	84 - 84	2122	2122
MX	495 Leleu	82 - 83	519 SI	2121
	500 Cross	82 - 82	2118	2121
EXC-F	500	12 - 22	671 SI	791 SI
GS	500 500 K4 Enduro	83 - 83	519 SI	2121
LC	500	85 - 85	519 SI	2122
LC	500	86 - 89	519 SI	519 SI
MX	500	83 - 84	2122	2122
MX	500	85 - 85	519 SI	2122
MX	500	86 - 86	519 SI	519 SI
MX	500	87 - 87	601 HF	601 HF
MX	500	88 - 88	621 HF	621 HF
MX	500	89 - 91	546 SI	692 SI
MX	500	92 - 93	671 SI	692 SI
XC	500 , MC	81 - 83	519 SI	
XCF-W	500	12 - 17	671 RSI	791 RSI
SX	505 ATV	08 - 12	866 RSI*	867 RSI
SX	505 Racing	07 - 09	671 RSI	791 RSI
XC	505 ATV	08 - 12	866 SI*	867 SI
XC-F	505	08 - 09	671 RSI	791 RSI
EXC	520 Racing	00 - 02	671 SI	675 SI
SX-F	520 Racing	00 - 02	671 RSI	675 RSI
EXC	525 Racing	03 - 03	671 SI	675 SI
EXC	525 Racing	04 - 06	671 SI	791 SI
SX	525 SMR	04 - 07	842 RSI	791 RSI
SX-F	525 Racing	03 - 03	671 RSI	675 RSI
SX-F	525 Racing	04 - 06	671 RSI	791 RSI
XC-F	525	07 - 07	671 RSI	791 RSI
XCF-W	525	07 - 07	671 RSI	791 RSI
EXC	530 Racing	08 - 11	671 SI	791 SI
XCF-W	530	09 - 11	671 RSI	791 RSI
SXC	540 Tiainen Replica	99 - 00	671 SI	675 SI
LC4	550	87 - 89	601 HF	601 HF
MX	550	87 - 90	601 HF	601 HF
SX	560 SMR	06 - 07	843 RSI	791 RSI
	600 Duke	93 - 94	566 HF	
4T	600 Enduro	84 - 86	519 SI	
EXC	600	87 - 87	601 HF	601 HF
EXC	600	88 - 88	621 HF	621 HF
GS	600	84 - 84	2122	2122
GS	600	85 - 85	519 SI	2122
LC4	600	88 - 91	601 HF	601 HF
LC4	600 Enduro	88 - 91	601 HF	601 HF
LC4	600 Six Days	92 - 92	671 SI	586 SI
MC	600	88 - 88	601 HF	601 HF
MX	600	87 - 87	601 HF	601 HF

**RECOMMENDED**1xx - 2xx = Scooter Pads  
5xx - 9xx = Street, Off Road & Racing Pads  
2xxx = Brake Shoes

			<b>RECOMMENDED</b>	
<b>KTM</b>				
MX	600	88 - 89	621 HF	621 HF
XC	600 Cross	85 - 85	519 SI	
XCE	600 Cross	85 - 85	519 SI	
	620 Duke	96 - 98	566 HF	519 HF
LC4	620 Competition	99 - 02	671 SI	675 SI
LC4	620 Competition SuperMoto	00 - 01	671 HF	675 HF
LC4	620 RXC	95 - 95	671 SI	675 SI
LC4	620 Supercompetition	01 - 01	671 HF	675 HF
SC	620	99 - 00	671 SI	675 SI
SX	620	95 - 99	671 RSI	675 RSI
LC4	625 SC Supermoto	02 - 04	671 HF	675 HF
SMC	625	05 - 06	706 HF	675 HF
SXC	625	03 - 04	671 HF	675 HF
	640 Duke	99 - 02	566 HF	519 HF
	640 Duke	03 - 06	706 HF	675 HF
LC4	640 Adventure	99 - 04	671 HF	675 HF
LC4	640 Adventure	05 - 07	674 HF	675 HF
LC4	640 Supermoto	03 - 03	566 HF	675 HF
LC4	640 Supermoto	04 - 04	706 HF	675 HF
LC4-E	640 Enduro	99 - 04	671 HF	675 HF
LC4-E	640 Supermoto	99 - 02	671 HF	675 HF
LC4	660 Rallye	01 - 03	671 HF	675 HF
LC4	660 SM Factory Replica	02 - 02	566 RSI	675 RSI
SMC	660 Supermoto	03 - 03	566 HF	675 HF
SMC	660 Supermoto	04 - 07	706 HF	675 HF
	690 Duke	08 - 11	762 HS	675 LS
	690 Duke ABS	12 - 19	706 HS	675 LS
	690 Duke R	10 - 11	762 HS	675 LS
	690 Duke R	14 - 17	841 HS	675 LS
	690 Enduro	08 - 14	674 HS	675 LS
	690 Enduro R	09 - 21	674 HS	675 LS
	690 SM	07 - 11	762 HS	675 LS
	690 SMC	08 - 10	762 HS	675 LS
	690 SMC R	14 - 20	762 HS	675 LS
	690 Supermoto R	08 - 09	762 HS	675 LS
	790 Adventure	19 - 20	706 HS*	671 LS
	790 Adventure R	19 - 20	706 HS*	671 LS
	790 Adventure R Rally	20 - 20	706 HS*	671 LS
	790 Duke	18 - 20	706 HS*	675 LS
	890 Adventure R	21 - 21	706 SP*	671 LS
	890 Duke R	20 - 20	901 SP*	675 LS
RC8	890 C	22 - 22	841 RST*	730 LS
	950 R Superenduro	06 - 08	674 HS	671 LS
	950 SM	05 - 07	762 HS*	671 LS
	950 SM R	07 - 09	762 HS*	671 LS
LC8	950 Adventure	02 - 07	674 HS*	671 LS
	990 Adventure R	10 - 12	674 HS*	671 LS
	990 Adventure, Adventure S, ABS	06 - 11	674 HS	671 LS
	990 Super Duke	04 - 13	762 HS*	675 LS
	990 Super Duke R	09 - 13	762 HS*	675 LS
	990 Supermoto	07 - 11	762 HS*	671 LS
	990 Supermoto R	10 - 10	841 HS*	671 LS
	990 Supermoto T	09 - 13	762 HS*	671 LS
	1050 Adventure	15 - 16	706 SP*	671 LS
	1090 Super Adventure	17 - 19	706 SP*	671 LS
	1090 Super Adventure R	17 - 20	706 SP*	671 LS
	1190 Adventure	13 - 16	706 SP*	671 LS
RC8	1190	08 - 11	841 SP*	730 LS
RC8	1190 R	09 - 15	841 SP*	730 LS
RC8	1190 R Track	11 - 15	841 SP*	730 LS
	1290 Super Adventure	15 - 16	706 SP*	671 LS
	1290 Super Adventure R	17 - 20	706 SP*	671 LS
	1290 Super Adventure S	17 - 20	706 SP*	671 LS
	1290 Super Adventure T	17 - 19	706 SP*	671 LS
	1290 Super Duke GT	16 - 20	901 SP*	730 LS
	1290 Super Duke R	14 - 22	841 HS*	730 LS

\* = 2 sets required / 2 jeux pour l'Avant.



**RECOMMENDED**

1xx - 2xx = Scooter Pads  
5xx - 9xx = Street, Off Road & Racing Pads  
2xxx = Brake Shoes



KTM				
	1290 Super Duke R EVO	22 - 22	841 SP*	730 LS
	1290 Superduke R Black	20 - 20	841 SP*	730 LS
KYMCO				
	50 Agility	05 - 08	163 HF	2012
	50 Agility (4T) R10	06 - 14	163 HF	2012
	50 Agility (4T) R12	06 - 15	163 HF	2012
	50 Agility (4T) R16	06 - 15	154 HF	2203
	50 Agility Basic	07 - 07	2012	2012
	50 MXU	05 - 10	2012*	749 HF
	50 People	99 - 06	154 HF	2203
	50 Super-8	08 - 16	154 HF	2203
	50 Super-9	00 - 01	144 HF	
	50 Super-9 A/C	02 - 07	119 HF	
	50 Super-9 L/C	02 - 07	119 HF	154 HF
CX	50 Curio Super	94 - 97	121 HF	2057
RS	50 Agility Naked	10 - 15	163 HF	
ZX	50 Super Fever	02 - 06	144 HF	
	125 Agility	06 - 11	163 CT	2012
	125 Agility 16+	14 - 16	154 CT	119 CT
	125 Agility City	11 - 17	163 CT	113 CT
	125 Dink X	22 - 22	159 CT	204 CT
	125 Downtown i	10 - 14	183 CT	204 CT
	125 K-Pipe	13 - 15	688 HF	
	125 Like	11 - 16	163 CT	
	125 New Downtown	16 - 17	159 CT	204 CT
	125 People	01 - 09	154 CT	2203
	125 People GTi	12 - 15	159 CT	204 CT
	125 People One i	14 - 16	154 CT	
	125 Super Dink	10 - 15	183 CT	204 CT
	125 Super-8	08 - 15	154 CT	
	125 Super-9	00 - 01	144 CT	154 CT
	125 X-Town CT	20 - 20	159 CT	204 CT
DT	125 X360	22 - 22	159 CT	204 CT
S	125 People	05 - 08	154 CT	195 CT
	150 MXU	05 - 17	2012*	749 HF
	150 People	01 - 06	154 CT	2203
	150 Quannon	10 - 14	119 CT	119 CT
	200 Agility 16+	14 - 17	154 CT	119 CT
	200 Agility R16	11 - 15	154 CT	119 CT
	200 Downtown i	10 - 15	183 CT	204 CT
	200 Like i	10 - 16	119 CT	119 CT
	200 People GTi	12 - 15	159 CT	204 CT
S	200 People	05 - 07	154 CT	195 CT
	250 MXU	06 - 14	810 SI*	775 SI
	250 People	03 - 12	119 MS	
	250 Super-9	00 - 05	144 CT	154 CT
	250 Urban Quad	06 - 06	810 SI*	775 SI
	250 Venox	01 - 14	627 HF	627 HF
	250 Xciting	04 - 05	183 MS	183 MS
	250 Xciting	06 - 09	183 MS	195 MS
KXR	250	04 - 14	810 SI*	775 SI
	300 Agility+	20 - 20	204 MS	204 MS
	300 Downtown i	10 - 15	183 MS	204 MS
	300 Maxxer	06 - 13	810 SI*	775 SI
	300 Maxxer Supermoto	15 - 15	810 SI*	775 SI
	300 MXU	06 - 17	810 SI*	810 SI*
	300 People GTi	10 - 11	183 MS	
	300 People GTi	12 - 15	159 MS	204 MS
	300 People S	20 - 20	159 MS	204 MS
	300 Xciting Ri	08 - 14	183 MS*	195 MS
	300 X-Town CT	20 - 20	159 MS	204 MS
	350 New Downtown	16 - 17	159 MS	204 MS
	400 Maxxer	08 - 10	822 ATS*	822 ATS
	400 Maxxer (Parking Brake)	08 - 10		921 HF
	400 MXU	08 - 11	822 ATS*	822 ATS
	400 MXU (Parking Brake)	08 - 11		921 HF
	400 Xciting i	12 - 14	214 MS*	212 MS



**RECOMMENDED**

1xx - 2xx = Scooter Pads  
5xx - 9xx = Street, Off Road & Racing Pads  
2xxx = Brake Shoes



KYMCO				
S	400 Xciting i TCS	22 - 22	214 MS	212 CT
	450 i Maxxer	10 - 14	822 ATS*	822 ATS
	450 i Maxxer (Parking Brake)	10 - 14		921 HF
	450 i MXU	11 - 14	822 ATS*	822 ATS
	450 i MXU (Parking Brake)	11 - 14		921 HF
	500 MXU	06 - 08	810 SI*	810 SI*
	500 MXU	09 - 14	945 SI*	
	500 MXU DX	11 - 13	945 SI*	
	500 UXV 4x4	08 - 14	810 SI*	810 SI
	500 Xciting	04 - 15	183 MS*	212 MS
	500 Xciting i Evo ABS	11 - 13	183 MS*	212 MS
	500 Xciting R ABS	09 - 13	183 MS*	212 MS
	550 MXU	12 - 20	945 SI*	810 SI
AK	550 ST	22 - 22	900 HS*	
	700 MXU	13 - 20	945 SI*	810 SI
UXV	700	14 - 16	945 SI*	
LAVERDA				
HP	125 Quasar	04 - 04		758 ATS
HP	180 Quasar	04 - 04		758 ATS
GS	350 Lesmo	86 - 89	519 HF*	519 HF
	400 Quasar 4x4	04 - 04	758 ATS*	758 ATS
	500 Alpino, S	77 - 83	519 HF*	519 HF
	500 Quasar 4x4	04 - 04	758 ATS*	758 ATS
	500 Quasar 4x4 C	04 - 04	758 ATS*	758 ATS
OR	600 Atlas	86 - 90	594 HF	519 HF
SFC	600	86 - 89	506 HF*	506 HF
	650	92 - 92	566 HF*	519 HF
	650 V-Six	93 - 93	506 HS*	506 LS
	668 668	96 - 97	566 HF	519 HF
	668 Ghost, Diamante	97 - 97	566 HF*	519 HF
	700 El Cid	90 - 90	546 HF	586 HF
	750 Cup	98 - 01	566 HF*	519 HF
	750 Diamante	97 - 01	566 HF*	519 HF
	750 Ghost Strike	97 - 01	566 HF*	519 HF
	750 S Formula	97 - 01	566 HF*	519 HF
	750 S, S Carenata	97 - 01	566 HF*	519 HF
	750 Sport	99 - 01	566 HF*	519 HF
	750 Strike/Black Strike	99 - 01	566 HF*	519 HF
	750 T8	98 - 01	566 HF*	519 HF
TTS	800	99 - 99	566 HF*	730 HF
	1000 Jota	76 - 79	506 HF*	506 HF
3C	1000 3CE, 3CL	74 - 75	506 HF*	506 HF
JOTA	1000	95 - 95	566 HF	519 HF
RGS	1000	83 - 83	506 HF*	506 HF
RGS	1000 Jota	86 - 86	506 HF*	506 HF
SFC	1000	85 - 86	506 HF*	506 HF
SFC	1000	04 - 04	762 HS*	730 LS
TGA	1000 Executive	84 - 84	506 HF*	506 HF
	1200 Mirage	78 - 80	506 HF*	506 HF
LEM				
	50 CX2, CX3, RX2, RX3	03 - 06	794 RSI	794 RSI
	50 R2, R3, R3 XC	03 - 06	794 RSI	794 RSI
RX	65	05 - 10	794 RSI	794 RSI
RX	150	11 - 11		794 RSI
MAICO				
	all models	89 - 89	621 HF	621 HF
	all models	91 - 91	621 HF	586 SI
	250 Motocross/Enduro	99 - 01	671 SI	675 SI
GM	250 LC	85 - 85	519 SI	
GM	250 Star	86 - 86	581 HF	581 HF
GP	250 all models	89 - 89	621 HF	621 HF
GP	250 E	87 - 87	581 HF	581 HF
GP	250 Motocross	87 - 87	581 HF	581 HF
MD	250	83 - 85	519 SI	519 SI
	350	93 - 95	621 HF	621 HF

\* = 2 sets required / 2 jeux pour l'Avant.

Full compound selection, see under "Brake pad 1:1 Drawings" / Sélection complète de composés, voir "1:1 Schémas Plaquettes de frein".

**RECOMMENDED**1xx - 2xx = Scooter Pads  
5xx - 9xx = Street, Off Road & Racing Pads  
2xxx = Brake Shoes

<b>MAICO</b>					
GP	400 all models	89 - 89	621 HF	621 HF	
GP	400 E	87 - 88	581 HF	581 HF	
GP	400 Motocross	87 - 88	581 HF	581 HF	
	500	93 - 94	621 HF	621 HF	
	500 Motocross/Enduro	99 - 99	671 SI	675 SI	
	500 Supermotard	99 - 99	671 HF	675 HF	
GM	500 LC	85 - 86	519 SI		
GM	500 Star	86 - 86	581 HF	581 HF	
GP	500 all models	89 - 89	621 HF	621 HF	
GP	500 E	87 - 87	581 HF	581 HF	
GP	500 Motocross	87 - 87	581 HF	581 HF	
GP	550	87 - 87	581 HF	581 HF	

**MALAGUTI**

	50 AJP Caliper incl. pin/spring	91 - 19	188 HF		
	50 Centro	93 - 96	109 HF	2012	
	50 Chopper 25, 40, 80, Fifty	83 - 83	532 HF		
	50 Chopper HF, Watercooled	83 - 83	532 HF		
	50 Enduro	85 - 87	519 HF		
	50 Enduro Dune	87 - 88	132 HF	132 HF	
	50 Evolution	91 - 91	574 HF		
	50 Fifty Evolution	91 - 91	559 HF		
	50 Fifty Full, CX, Top	85 - 85	595 HF		
	50 Fifty Mistral	90 - 95	595 HF		
	50 Yesterday	97 - 02	123 HF	2012	
CH	50	86 - 86	595 HF		
CR-1	50 Crosser	95 - 96	132 HF		
EL	50 Crosser	97 - 00	123 HF		
ES	50 Dune	89 - 89	574 HF	574 HF	
F-10	50	92 - 93	113 HF	2012	
F-10	50 Jet-Line	94 - 98	123 HF	2012	
F-12	50 Phantom	94 - 98	132 HF	2012	
F-12	50 Phantom A.C.	99 - 03	123 HF	2012	
F-15	50 Fire Fox	96 - 08	132 HF	2012	
F-15	50 Fire Fox L.C.	96 - 08	109 HF	2012	
MDX	50	86 - 87	574 HF		
MDX	50 Gold Enduro	87 - 87	607 HF	596 HF	
MEX	50	86 - 87	541 HF		
MFX	50	86 - 87	541 HF		
MLX	50 Enduro	87 - 87	607 HF	596 HF	
MRX	50	89 - 89	519 HF		
RCW	50 Ronco	83 - 83	532 HF		
RST	50	90 - 90	519 HF	519 HF	
RST	50 Sport	87 - 87	574 HF	574 HF	
SL	50 Centro	96 - 00	123 HF	2012	
V4	50 Olympique	83 - 83	532 HF		
XL	50 Sport	83 - 85	532 HF		
	125 Monte	20 - 20	205 CT	102 CT	
	125 Runner	86 - 86	532 HF		
	125 Runner	87 - 87	108 CT		
R	125 Madison	99 - 09	120 CT	152 CT	
	250 Madison	99 - 04	159 MS	152 MS	
MGX	425 Ronco	87 - 11	541 HF		
MGX	450 Ronco	87 - 11	595 HF		

**MONDIAL**

	1000 EVO	04 - 04	762 HS*	730 LS	
	1000 Piega	03 - 04	762 HS*	730 LS	
	1000 RZ Nuda	04 - 04	762 HS*	730 LS	
	1000 Starfighter	04 - 04	762 HS*	730 LS	

**MONTESA**

	250 Cota 4RT	04 - 16	802 RSI	803 RSI	
Cota	260 4Ride	16 - 19	939 RSI	803 RSI	
Cota	260 4RT	04 - 16	802 RSI	803 RSI	

**RECOMMENDED**1xx - 2xx = Scooter Pads  
5xx - 9xx = Street, Off Road & Racing Pads  
2xxx = Brake Shoes

<b>MONTESA</b>					
Cota	260 4RT Race Replica	15 - 19	939 RSI	803 RSI	
Cota	300 RR	16 - 19	939 RSI	803 RSI	
	360 315R	01 - 04	802 RSI	803 RSI	

**MORIWAKI**

MD	250	09 - 09	782 DC	618 RQ	
----	-----	---------	--------	--------	--

**MOTO-GUZZI**

	125 Custom	85 - 85	519 HF		
	125 Enduro TT	85 - 85	519 HF		
BX	125	92 - 92	519 HF	519 HF	
	240 /4	77 - 77	519 HF		
	250 TS	75 - 76	519 HF		
	350	77 - 81	519 HF*	519 HF	
	350 Falco	88 - 88	519 HF	519 HF	
	350 Imola	78 - 84	519 HF*	519 HF	
	350 Nevada	92 - 97	519 HF*		
NTX	350	88 - 88	519 HF	519 HF	
NTX	350	90 - 90	519 HF	506 HF	
V35	350 C	82 - 86	506 HF*	519 HF	
V35	350 Florida	85 - 86	506 HF*	519 HF	
V35	350 GT	77 - 77	519 HF		
V35	350 GT	90 - 90	506 HF	519 HF	
V35	350 II, Imola, Imola II	77 - 77	519 HF*	519 HF	
V35	350 III	87 - 87	506 HF*	506 HF	
V35	350 TT	86 - 86	506 HF*	506 HF	
	400	77 - 84	519 HF*	519 HF	
	500	77 - 80	519 HF*	519 HF	
	500 Monza	78 - 85	519 HF*	519 HF	
V50	500 1,2,3, Monza Chopper	77 - 77	519 HF*	519 HF	
	650	80 - 84	519 HF*	519 HF	
	650 Florida	85 - 84	519 HF*	519 HF	
GT	650 Sessantacinque	89 - 89	519 HF*	519 HF	
NTX	650	90 - 02	519 HF	506 HF	
V65	650 Florida	86 - 94	506 HF*	506 HF	
V65	650 GT	90 - 94	506 HF	598 HF	
V65	650 Lario	86 - 94	519 HF*	519 HF	
V65	650 NTX	87 - 02	519 HF	519 HF	
V65	650 SP, Chopper	80 - 84	519 HF*	519 HF	
V65	650 TT	86 - 94	519 HF*	519 HF	
	750 Brevia	03 - 09	706 HS	730 LS	
	750 Ippogrifo	97 - 97	566 HF	519 HF	
	750 Nevada	92 - 96	519 HF*		
	750 Nevada Classic ie	06 - 11	706 HF	730 HF	
	750 Nevada, Club/Base	97 - 02	519 HF*	519 HF	
	750 Nevada, Nevada Club	03 - 16	706 HF	730 HF	
	750 Targa	89 - 89	519 HF*	519 HF	
NTX	750	89 - 89	519 HF	519 HF	
NTX	750	90 - 93	596 HS	506 LS	
S3	750	75 - 76	506 HF*		
SP	750	91 - 92	506 HS	506 LS	
V7	750 Cafe Classic	10 - 13	706 HS	730 LS	
V7	750 Classic	09 - 12	706 HS*	730 LS	
V7	750 Clubman Racer	10 - 10	706 HS*	730 LS	
V7	750 Racer	11 - 11	706 HS	730 LS	
V7	750 Racer	12 - 14	706 HS	588 HF	
V7	750 Stone	12 - 14	706 HS	588 HF	
V7 II	750 Racer	15 - 16	706 HS	588 HF	
V7 II	750 Scrambler	16 - 16	706 HS	588 HF	
V7 II	750 Special	15 - 16	706 HS	588 HF	
V7 II	750 Stone	15 - 16	706 HS	588 HF	
V7 II	750 Stornello	16 - 16	706 HS	588 HF	
V7 II	750 Stornello Ltd. Edition	17 - 18	706 HS	588 HF	
V7 III	750 Anniversario	17 - 18	706 HS	588 HF	
V7 III	750 Carbon	18 - 19	706 HS	588 HF	
V7 III	750 Euro 4	17 - 19	706 HS	588 HF	
V7 III	750 Limited	19 - 19	706 HS	588 HF	
V7 III	750 Milano	18 - 20	706 HS	588 HF	

\* = 2 sets required / 2 jeux pour l'Avant.





**RECOMMENDED**

1xx - 2xx = Scooter Pads  
5xx - 9xx = Street, Off Road & Racing Pads  
2xxx = Brake Shoes



MOTO-GUZZI					
V7 III	750 Racer	17 - 20	706 HS	588 HF	
V7 III	750 Rough	18 - 20	706 HS	588 HF	
V7 III	750 Special	17 - 19	706 HS	588 HF	
V7 III	750 Stone	17 - 20	706 HS	588 HF	
V75	750	86 - 88	506 HF*	506 HF	
V75	750 Duna	86 - 90	506 HF	506 HF	
V75	750 TT Paris-Dakar	86 - 86	506 HF	506 HF	
	850 Brevia	06 - 09	706 HS*	730 LS	
	850 Le Mans	76 - 79	506 HF*	506 HF	
	850 V7 Special	22 - 22	706 SP	588 HF	
	850 V7 Stone	22 - 22	706 SP	588 HF	
	850 V7 Stone Fast				
	Endurance	22 - 22	706 SP	588 HF	
T	850	74 - 76	506 HF		
T3	850	75 - 80	506 HF*	506 HF	
T4	850	75 - 82	506 HF*	506 HF	
T5	850	75 - 88	506 HF*	506 HF	
T5	850 N.T.	86 - 88	506 HF*	506 HF	
V85	850 TT	19 - 19	706 HS*	588 HF	
V85	850 TT Guardia d'Onore	22 - 22	706 SP*	588 HF	
V85	850 TT travel	20 - 20	706 HS*	588 HF	
V9	850 Bobber	16 - 17	706 HS	588 HF	
V9	850 Bobber Sports	19 - 20	706 HS	588 HF	
V9	850 Roamer	16 - 17	706 HS	588 HF	
V9	850 X-Track	17 - 17	706 HS	588 HF	
	940 Custom	07 - 07	706 HS*	674 LS	
	1000	81 - 83	554 HF*	554 HF	
	1000 California II	85 - 88	506 HF*	506 HF	
	1000 California III C	91 - 95	506 HS*	506 LS	
	1000 California III,				
	Fuel Injection	89 - 89	506 HF*	506 HF	
	1000 Daytona	91 - 02	566 HF*	506 HF	
	1000 Le Mans IV	85 - 89	506 HF*	506 HF	
	1000 Le Mans, V	90 - 98	506 HS*	506 LS	
	1000 Quota	92 - 92	566 HF*	614 HF	
GT	1000 V	91 - 91	506 HS*	506 LS	
RS	1000 Daytona	97 - 00	566 HF*	519 HF	
S	1000	90 - 90	506 HS*	506 LS	
SP	1000 III	91 - 94	506 HS*	506 LS	
SP	1000 Le Mans	79 - 83	506 HF*	554 HF	
V	1000 Strada	93 - 94	506 HF*	519 HF	
V10	1000 Centauro	96 - 00	566 HF*	519 HF	
V100	1042 Mandello	22 - 22	900 SP*	671 LS	
	1100 California	96 - 99	506 HS*	506 LS	
	1100 California EV	06 - 06	706 HS	674 LS	
	1100 California EV Touring	06 - 06	706 HS	674 LS	
	1100 California Jackal	00 - 00	566 HF*	674 HF	
	1100 California Jackal	01 - 06	706 HS*	674 LS	
	1100 California Jackal Basic	00 - 00	566 HF	674 HF	
	1100 California Jackal Basic	01 - 06	706 HS	674 LS	
	1100 California Special	99 - 00	566 HF*	674 HF	
	1100 California Special	01 - 01	706 HS*	674 LS	
	1100 California Special				
	Sport Alloy	02 - 06	706 HS*	674 LS	
	1100 California Stone Metal	02 - 03	706 HS	674 LS	
	1100 California Stone,				
	Stone Touring	02 - 05	706 HS	674 LS	
	1100 California Titanium	03 - 05	706 HS*	674 LS	
	1100 California Vintage	06 - 13	706 HS*	674 LS	
	1100 Griso	05 - 10	706 HS	674 LS	
	1100 Sport	96 - 04	566 HF*	519 HF	
ES	1100 Quota	99 - 03	674 HF*	671 HF	
EV	1100 California	97 - 00	566 HF*	519 HF	
EV	1100 California, 80,				
	Touring	01 - 01	706 HS*	519 LS	
V	1100 Brevia	04 - 04	706 HS	730 LS	
V	1100 Brevia, ABS	05 - 07	706 HS	671 LS	
V11	1100 , Scura, Sport Scura	02 - 05	706 HS*	519 LS	



**RECOMMENDED**

1xx - 2xx = Scooter Pads  
5xx - 9xx = Street, Off Road & Racing Pads  
2xxx = Brake Shoes



MOTO-GUZZI					
V11	1100 Lemans,				
	Lemans Tenni,				
	Lemans Rosso Corsa	01 - 06	706 HS*	519 LS	
V11	1100 Sport	97 - 00	566 HF*	519 HF	
V11	1100 Sport Rosso Mandell	01 - 06	706 HS*	519 LS	
V11	1100 Sport, Sport Naked	01 - 05	706 HS*	519 LS	
	1200 Griso 8V	07 - 13	706 HS*	671 LS	
	1200 Griso 8V SE	18 - 18	706 HS*	671 LS	
	1200 MGS-01 Corsa	05 - 13	762 SP*	730 LS	
	1200 Norge	06 - 14	706 HS*	671 LS	
	1200 Norge GT 8V	10 - 13	706 HS*	671 LS	
	1200 Sport	07 - 08	706 HS*	671 LS	
	1200 Sport 4V	09 - 11	706 HS*	730 LS	
	1200 Sport 8V	12 - 13	706 HS*	671 LS	
	1200 Sport 8V SE	12 - 15	706 HS*	671 LS	
	1200 Stelvio	08 - 11	706 SP*	671 LS	
	1200 Stelvio 8V SE	12 - 16	706 SP*	671 LS	
	1200 Stelvio NTX	09 - 11	706 SP*	671 LS	
V	1200 Brevia	08 - 13	706 HS	671 LS	
	1400 Audace	15 - 17	706 HS*	674 LS	
	1400 California Custom	13 - 15	706 HS*	674 LS	
	1400 California Touring	13 - 15	706 HS*	674 LS	
	1400 California Touring SE	16 - 17	706 HS*	674 LS	
	1400 Eldorado	15 - 17	706 HS*	674 LS	
MGX-21	1400 Flying Fortress	15 - 17	706 HS*	674 LS	
<b>MOTO-MORINI</b>					
	125 KJ	84 - 88	606 HF		
	125 Strada	80 - 80	560 HF		
	250 Strada	80 - 80	560 HF		
XE	250 Country	88 - 88	519 HF		
	350 Coguaro	90 - 95	608 HF	519 HF	
	350 Coguaro, New York	90 - 94	608 HF	519 HF	
	350 Dart	88 - 88	608 HF	519 HF	
	350 Dart	90 - 92	641 HF	519 HF	
	350 Excalibur	86 - 86	594 HF	594 HF	
	350 Excalibur	87 - 89	588 HF	606 HF	
	350 Indiana	88 - 88	594 HF	519 HF	
	350 K2	84 - 87	560 HF	606 HF	
	350 Kanguro	88 - 88	588 HF	519 HF	
	350 Strada	76 - 81	560 HF		
RLX	350 Excalibur	90 - 92	608 HF	519 HF	
	400 Dart	89 - 89	608 HF	519 HF	
	400 Dart	90 - 92	641 HF	519 HF	
	400 S	82 - 82	519 HF*	519 HF	
	500 Sei V Classic	89 - 89	519 HF*		
	500 Strada	80 - 82	560 HF		
	501 Camel	88 - 88	588 HF	519 HF	
	501 Coguaro	89 - 89	608 HF	519 HF	
	501 New York	89 - 89	594 HF	519 HF	
RLX	501 Excalibur	86 - 86	594 HF	594 HF	
RLX	501 Excalibur	87 - 87	588 HF	606 HF	
RLX	501 Excalibur	88 - 89	594 HF	519 HF	
RLX	501 Excalibur	90 - 90	608 HF	519 HF	
	649 X-Cape	22 - 22	674 HS*	730 LS	
	650 Indiana	88 - 88	594 HF	519 HF	
	650 Seiemmezzo	20 - 20	674 HS*	671 LS	
	650 X-Cape	20 - 20	674 HS*	671 LS	
	750 Indiana	88 - 88	594 HF	519 HF	
	1200 11 1/2	18 - 18	706 HS*	730 LS	
	1200 9 1/2	06 - 09	706 HS*	730 LS	
	1200 Corsaro	06 - 13	706 HS*	730 LS	
	1200 Corsaro ZT	20 - 20	901 SP*	730 LS	
	1200 Corsaro ZZ	18 - 20	901 HS*	730 LS	
	1200 Granferro	10 - 10	762 HS*	671 LS	
	1200 Granpasso	08 - 13	674 HS*	671 LS	
	1200 GT	10 - 10	674 HS*	671 LS	
	1200 Milano	18 - 19	901 HS*	730 LS	

\* = 2 sets required / 2 jeux pour l'Avant.

Full compound selection, see under "Brake pad 1:1 Drawings" / Sélection complète de composés, voir "1:1 Schémas Plaquettes de frein".

**RECOMMENDED**1xx - 2xx = Scooter Pads  
5xx - 9xx = Street, Off Road & Racing Pads  
2xxx = Brake Shoes

<b>MOTO-MORINI</b>				
	1200 Scrambler	09 - 10	674 HS*	671 LS
	1200 Scrambler	18 - 18	901 HS*	730 LS
	1200 Sport	08 - 13	706 HS*	730 LS
	1200 Super Scrambler	20 - 20	901 SP*	730 LS
<b>MOTUS</b>				
MST	1650	14 - 17	706 HS*	730 LS
MST-R	1650	14 - 17	841 HS*	730 LS
<b>MV AGUSTA</b>				
	675 Brutale	12 - 15	706 HS*	730 LS
F3	675	11 - 12	706 HS*	763 LS
F3	675	13 - 14	706 HS*	730 LS
F3	675	15 - 20	901 HS*	730 LS
F3	675 RC	16 - 20	901 HS*	730 LS
	750 Brutale, Brutale S	01 - 05	676 HS*	763 LS
F4	750	99 - 02	676 HS*	763 LS
F4	750 SPR	01 - 03	676 HS*	763 LS
	800 Brutale	13 - 20	706 HS*	730 LS
	800 Brutale Dragster	15 - 19	706 HS*	730 LS
	800 Brutale Dragster RC	17 - 20	706 HS*	730 LS
	800 Brutale Dragster RR	15 - 19	706 HS*	730 LS
	800 Brutale Dragster RR LH44	18 - 20	706 HS*	730 LS
	800 Brutale Dragster RR Pirelli	18 - 20	706 HS*	730 LS
	800 Brutale RC	18 - 20	706 HS*	730 LS
	800 Brutale RR	16 - 20	706 HS*	730 LS
	800 Rivale	13 - 17	900 HS*	730 LS
	800 RVS#1	18 - 20	706 HS*	730 LS
	800 Stradale	15 - 16	900 HS*	730 LS
	800 Superverloce	19 - 19	841 SP*	730 LS
	800 Superverloce	20 - 20	901 SP*	730 LS
	800 Turismo Veloce	14 - 19	900 HS*	730 LS
	800 Turismo Veloce Lusso	14 - 20	900 HS*	730 LS
	800 Turismo Veloce RC	17 - 20	900 HS*	730 LS
F3	800	14 - 20	901 HS*	763 LS
F3	800 RC	16 - 20	901 HS*	730 LS
F3	800 RR	21 - 22	841 SP*	730 LS
	910 Brutale	06 - 08	676 HS*	763 LS
	910 Brutale R	06 - 08	762 HS*	763 LS
	910 Brutale S	06 - 08	676 HS*	763 LS
	920 Brutale	12 - 14	706 HS*	763 LS
	989 Brutale R	09 - 09	706 HS*	763 LS
	990 Brutale R	10 - 11	706 HS*	763 LS
	1000 Brutale RR	20 - 20	841 SP*	730 LS
	1000 Rush	20 - 20	841 SP*	
F4	1000 LH44	18 - 20	841 SP*	763 LS
F4	1000 Mamba	04 - 06	676 HS*	763 LS
F4	1000 R	06 - 07	762 HS*	763 LS
F4	1000 R	12 - 19	841 SP*	763 LS
F4	1000 RC	15 - 20	841 SP*	763 LS
F4	1000 RR	12 - 20	841 SP*	763 LS
F4	1000 S	04 - 06	676 HS*	763 LS
F4	1000 Tamburini	04 - 06	676 HS*	763 LS
	1078 Brutale RR	09 - 09	841 HS*	763 LS
F4	1078 CC	08 - 11	841 SP*	763 LS
F4	1078 RR	08 - 11	841 SP*	763 LS
	1090 Brutale Corse	14 - 16	841 HS*	763 LS
	1090 Brutale R	12 - 15	706 HS*	763 LS
	1090 Brutale RR	10 - 17	841 HS*	763 LS
<b>MZ</b>				
	660 (MUZ) Baghira	96 - 00	681 HF	684 HF
	660 (MUZ) Black Panther	00 - 06	681 HF	684 HF
	660 (MUZ) Mastiff	96 - 06	681 HF	684 HF
	660 (MUZ) Skorpion Cup	99 - 99	566 HF	519 HF
	660 (MUZ) Skorpion Replica	97 - 99	566 HF*	519 HF

**RECOMMENDED**1xx - 2xx = Scooter Pads  
5xx - 9xx = Street, Off Road & Racing Pads  
2xxx = Brake Shoes

<b>MZ</b>				
	660 (MUZ) Skorpion Sport	95 - 99	566 HF	519 HF
	660 (MUZ) Skorpion Tour	95 - 00	566 HF	519 HF
	660 (MUZ) Skorpion Traveller	99 - 00	566 HF	519 HF
	660 (MUZ) Street Moto	00 - 06	681 HF	684 HF
	660 (MUZ) Super Moto	07 - 07	681 HF	684 HF
	1000 (MUZ) S	01 - 02	706 HS*	691 HF
	1000 (MUZ) S	03 - 10	624 HS*	715 LS
	1000 (MUZ) SF	05 - 10	624 HS*	715 LS
	1000 (MUZ) SFX	07 - 07	624 HS*	715 LS
	1000 (MUZ) SN	05 - 05	624 HS*	715 LS
	1000 (MUZ) ST	07 - 10	624 HS*	715 LS
<b>NORTON</b>				
	600 Commander	90 - 90	506 HF*	506 HF
	600 Interpol	83 - 88	506 HF*	506 HF
	600 Wankel Classic	88 - 89	506 HF*	506 HF
F-1	600	90 - 90	566 HF*	506 HF
TT	600	92 - 92	566 HF*	
MK2	850 Commando	73 - 75	505 HF	
MK3	850 Commando	75 - 77	505 HF	505 HF
	961 Commando Cafe Racer	11 - 14	762 HS*	730 LS
	961 Commando Cafe Racer MKII	18 - 19	900 HS*	730 LS
	961 Commando SE	10 - 11	706 HS*	730 LS
	961 Commando SE	12 - 14	762 HS*	730 LS
	961 Commando SF	13 - 15	762 HS*	730 LS
	961 Commando SF Sport	11 - 15	706 HS*	730 LS
	961 Commando Sport	18 - 19	900 HS*	730 LS
	961 Dominator Naked	17 - 19	900 HS*	730 LS
	1200 V4 RR	18 - 19	841 HS*	730 LS
<b>OHVALE</b>				
GP-01	110	17 - 19	885 RST	872 RQ
GP-01	160	17 - 19	885 RST	872 RQ
GP-01	190	17 - 19	885 RST	872 RQ
GP-2	190	21 - 21	962 RST	548 HF
GP-01	212	17 - 19	872 RST*	872 RQ
<b>OSSA</b>				
TR	125 i	15 - 15	802 RSI	803 RSI
TR	250 i	15 - 15	802 RSI	803 RSI
TR	280 i	10 - 15	802 RSI	803 RSI
TR	280 i Explorer	12 - 15	802 RSI	803 RSI
TR	300 Factory R	15 - 15	939 RSI	803 RSI
TR	300 i	15 - 15	802 RSI	803 RSI
<b>PEUGEOT</b>				
	e-Vivacity	11 - 15		2012
	50 Elyseo	02 - 05	105 HF	105 HF
	50 Elyseo (A.J.P. cal.)	99 - 01	105 HF	2012
	50 Elystar	03 - 05	105 HF	167 HF*
	50 Looxor	02 - 05	105 HF	2012
	50 Looxor	06 - 06	105 HF	105 HF
	50 Speedake (A.J.P. cal.)	94 - 01	105 HF	2012
	50 Speedake (Brembo cal.)	94 - 01	123 HF	2012
	50 Speedake (Hengtong cal.)	94 - 01	102 HF	2012
	50 Speedfight 2 A/C	01 - 08	105 HF	
	50 Speedfight 2 L/C	01 - 08	105 HF	105 HF
	50 Speedfight 2 X-Race, Furious, 206 WRC	01 - 02	105 HF	105 HF
	50 Speedfight 3 (AC)	10 - 16	200 HF	2012
	50 Speedfight 3 (LC)	10 - 16	200 HF	157 HF
	50 Speedfight 3 RS (LC)	10 - 16	200 HF	157 HF
	50 Speedfight 4 (AC)	15 - 16	200 HF	

\* = 2 sets required / 2 jeux pour l'Avant.



**RECOMMENDED**

1xx - 2xx = Scooter Pads  
5xx - 9xx = Street, Off Road & Racing Pads  
2xxx = Brake Shoes



**RECOMMENDED**

1xx - 2xx = Scooter Pads  
5xx - 9xx = Street, Off Road & Racing Pads  
2xxx = Brake Shoes



PEUGEOT			
50 Speedfight 4 (LC)	15 - 16	200 HF	157 HF
50 Speedfight LBD/LBDP	00 - 00	105 HF	105 HF
50 Speedfight LC, (A.J.P. cal.)	96 - 15	105 HF	2012
50 Speedfight LC, (Brembo cal.)	96 - 15	123 HF	2012
50 Speedfight LC, (Hengtong cal.)	96 - 15	102 HF	2012
50 Speedfight Lemans	11 - 11	105 HF	105 HF
50 Trekker Metal-X	01 - 08	105 HF	
50 Trekker Offroad	99 - 01	102 HF	
50 Trekker Road	99 - 00	105 HF	2012
50 Trekker Streetboard	00 - 02	105 HF	
50 Trekker Urban Black	00 - 00	105 HF	
50 Vivacity	08 - 14	100 HF	
50 Vivacity (A.J.P. cal.)	99 - 07	105 HF	
50 Vivacity (Hengtong cal.)	05 - 07	102 HF	
50 Vivacity Sportline	11 - 11	141 HF	
100 Elyseo	02 - 05	105 HF	105 HF
100 Elyseo (A.J.P. cal.)	99 - 01	105 HF	2012
100 Looxor	02 - 07	105 HF	105 HF
100 Speedfight	00 - 07	105 HF	105 HF
100 Speedfight 2, X-Race	01 - 07	105 HF	105 HF
100 Trekker Road	99 - 04	105 HF	
100 Vivacity (A.J.P. cal.)	99 - 07	105 HF	
100 Vivacity (Hengtong cal.)	05 - 07	102 HF	
125 Elyseo	00 - 07	168 CT	167 CT
125 Elyseo (A.J.P. cal.)	99 - 99	105 CT	
125 Elystar	03 - 07	168 CT	167 CT
125 Looxor	03 - 07	156 CT	167 CT
125 Vivacity	10 - 16	197 CT	
150 Elyseo	00 - 04	168 CT	167 CT
150 Elystar	03 - 04	168 CT	167 CT
PIAGGIO VESPA			
50 Typhoon	18 - 22	237 HF	
100 Fly	07 - 15		2205
100 Zip	07 - 10		2205
125 Liberty iGet 4T 3V	17 - 19	228 CT	
125 Medley	16 - 19	228 CT	187 CT
125 Medley S	17 - 19	228 CT	187 CT
125 MP3	06 - 07	202 CT*	191 CT
125 MP3 (Parking Brake)	06 - 07		209 HF
125 MP3 Efi	08 - 11	202 CT*	187 CT
125 MP3 Efi (Parking Brake)	08 - 11		209 HF
125 MP3 Hybrid	09 - 12	202 CT*	187 CT
125 MP3 Hybrid (Parking Brake)	09 - 12		209 HF
125 MP3 Yourban	11 - 12	202 CT*	187 CT
125 MP3 Yourban (Parking Brake)	11 - 12		209 HF
125 New Liberty	16 - 19	228 CT	
150 Fly	06 - 07		2205
150 Medley	16 - 19	228 CT	187 CT
250 MP3	06 - 07	202 MS*	191 MS
250 MP3 (Parking Brake)	06 - 07		209 HF
250 MP3 Efi	08 - 09	202 MS*	187 MS
250 MP3 Efi (Parking Brake)	08 - 09		209 HF
250 MP3 LT iE	09 - 09	202 MS*	187 MS
250 MP3 LT iE (Parking Brake)	09 - 09		209 HF
300 Beverly hpe	22 - 22	177 MS	134 MS
300 MP3 Hybrid	11 - 12	202 MS*	187 MS
300 MP3 Hybrid (Parking Brake)	11 - 12		209 HF
300 MP3 Hybrid iE	11 - 19	202 MS*	187 MS
300 MP3 Hybrid iE (Parking Brake)	11 - 19		209 HF



PIAGGIO VESPA			
300 MP3 iE	10 - 19	202 MS*	187 MS
300 MP3 iE (Parking Brake)	10 - 19		209 HF
300 MP3 LT	13 - 19	202 MS*	187 MS
300 MP3 LT (Parking Brake)	13 - 19		209 HF
300 MP3 LT Business	13 - 19	202 MS*	187 MS
300 MP3 LT Business (Parking Brake)	13 - 19		209 HF
300 MP3 LT iE ABS	14 - 19	224 MS*	187 MS
300 MP3 LT iE ABS (Parking Brake)	14 - 19		209 HF
300 MP3 LT Sport ABS	14 - 19	224 MS*	187 MS
300 MP3 LT Sport ABS (Parking Brake)	14 - 19		209 HF
300 MP3 LT Touring	11 - 12	202 MS*	187 MS
300 MP3 LT Touring (Parking Brake)	11 - 12		209 HF
300 MP3 Touring	11 - 12	202 MS*	187 MS
300 MP3 Touring (Parking Brake)	11 - 12		209 HF
300 MP3 Yourban iE	11 - 19	202 MS*	187 MS
300 MP3 Yourban iE (Parking Brake)	11 - 19		209 HF
400 Beverly hpe S	22 - 22	177 MS	187 MS
400 MP3 iE	07 - 10	202 MS*	177 MS
400 MP3 iE (Parking Brake)	07 - 10		209 HF
400 MP3 LT iE	09 - 10	202 MS*	177 MS
400 MP3 LT iE (Parking Brake)	09 - 10		209 HF
400 MP3 LT Touring	11 - 12	202 MS*	177 MS
400 MP3 LT Touring (Parking Brake)	11 - 12		209 HF
400 MP3 Touring	11 - 12	202 MS*	177 MS
400 MP3 Touring (Parking Brake)	11 - 12		209 HF
500 MP3	10 - 10	202 MS*	177 MS
500 MP3 (Parking Brake)	10 - 10		209 HF
500 MP3 LT Touring Business	11 - 13	202 MS*	177 MS
500 MP3 LT Touring Business (Parking Brake)	11 - 13		209 HF
500 MP3 LT Touring Business ABS	14 - 15	224 MS*	177 MS
500 MP3 LT Touring Business ABS (Parking Brake)	14 - 15		209 HF
500 MP3 LT Touring Sport	11 - 13	202 MS*	177 MS
500 MP3 LT Touring Sport (Parking Brake)	11 - 13		209 HF
500 MP3 LT Touring Sport ABS	14 - 15	224 MS*	177 MS
500 MP3 LT Touring Sport ABS (Parking Brake)	14 - 15		209 HF
500 MP3 Touring Business	11 - 12	202 MS*	177 MS
500 MP3 Touring Business (Parking Brake)	11 - 12		209 HF
500 MP3 Touring Sport	11 - 12	202 MS*	177 MS
500 MP3 Touring Sport (Parking Brake)	11 - 12		209 HF
POLARIS			
EV-LSV	10 - 11	897 ATS*	800 ATS
LSV 4x4	11 - 12	897 ATS*	800 ATS
Ranger 48v EV	13 - 18	897 ATS*	800 ATS
50 Predator	04 - 14	2048*	
50 Scrambler	01 - 03	2048*	
90 Predator	03 - 14	2043*	
90 Scrambler	01 - 03	2048*	

\* = 2 sets required / 2 jeux pour l'Avant.

Full compound selection, see under "Brake pad 1:1 Drawings" / Sélection complète de composés, voir "1:1 Schémas Plaquettes de frein".

**RECOMMENDED**1xx - 2xx = Scooter Pads  
5xx - 9xx = Street, Off Road & Racing Pads  
2xxx = Brake Shoes

POLARIS				
90 Sportsman	01 - 15	2048*		
170 Ranger RZR	09 - 18	905 SI*	906 SI	
200 Phoenix	05 - 09	544 ATS*	546 SI	
200 Phoenix	10 - 14	905 SI*	546 SI	
200 Sawtooth	06 - 07	544 ATS*	544 ATS	
250 2x4, 4x4	90 - 93	716 ATS*	717 ATS	
250 Big Boss 4x6, 6x6	89 - 93	716 ATS*	717 ATS	
250 Big Boss 4x6, 6x6				
Middle Axle Brake	89 - 93	717 ATS		
250 Cyclone	87 - 87	2028*	643 HF	
250 Trail Blazer	90 - 98	716 ATS*	717 ATS	
250 Trail Blazer	99 - 07	716 ATS*	755 ATS	
250 Trail Boss	88 - 90	642 ATS*	643 HF	
250 Trail Boss	91 - 99	716 ATS*	717 ATS	
250 Trail Boss 2x4, 4x4	91 - 92	716 ATS*	717 ATS	
250 Xplorer 4x4	00 - 02	716 ATS*	755 ATS	
300 2x4, 4x4	94 - 95	716 ATS*	717 ATS	
300 Big Boss 6x6	94 - 94	716 ATS*	717 ATS	
300 Big Boss 6x6				
Middle Axle Brake	94 - 94	717 ATS		
300 Hawkeye 2x4, 4x4	06 - 06	822 ATS*	822 ATS	
300 Hawkeye 2x4, 4x4	07 - 11	716 ATS*	716 ATS	
300 Sportsman 4x4	08 - 11	642 ATS*	642 ATS	
300 Xplorer 4x4	96 - 99	716 ATS*	717 ATS	
300 Xpress 2x4	98 - 99	716 ATS*	717 ATS	
300 Xpress L	96 - 97	716 ATS*	717 ATS	
325 Magnum 2x4, 4x4	00 - 02	716 ATS*	755 ATS	
325 Trail Boss	00 - 02	716 ATS*	755 ATS	
325 Xpedition	00 - 01	642 ATS*	755 ATS	
325 Xpedition	02 - 02	642 ATS*	787 ATS	
330 ATP	04 - 05	716 ATS*	716 ATS*	
330 ATP	06 - 05	716 ATS*	787 ATS*	
330 E Trail Blazer	08 - 12	642 ATS*	787 ATS	
330 Magnum 2x4, 4x4	03 - 13	716 ATS*	787 ATS	
330 Trail Boss	03 - 14	716 ATS*	755 ATS	
335 Sportsman 4x4	99 - 02	716 ATS*	755 ATS	
350 Big Boss	93 - 93	716 ATS*	717 ATS	
350 Big Boss				
Middle Axle Brake	93 - 93	717 ATS		
350 L 2x4, 4x4	90 - 90	716 ATS*	717 ATS	
350 L 4x4	93 - 93	716 ATS*	717 ATS	
350 Sportsman 4x4	93 - 93	716 ATS*	717 ATS	
350 Trail Boss 2x4	85 - 87	2028*		
350 Trail Boss 2x4, 4x4	88 - 89	716 ATS*	717 ATS	
350 Trail Boss L 2x4	91 - 93	716 ATS*	717 ATS	
350 Trail Boss L 4x4	91 - 91	716 ATS*	717 ATS	
400 Big Boss L 6x6	96 - 96	716 ATS*	717 ATS	
400 Big Boss L 6x6				
Middle Axle Brake	96 - 96	756 ATS		
400 L 2x4	94 - 95	716 ATS*	717 ATS	
400 L 4x4	94 - 94	716 ATS*	717 ATS	
400 Scrambler 2x4, 4x4	00 - 03	716 ATS*	755 ATS	
400 Scrambler 4x4	98 - 98	716 ATS*	717 ATS	
400 Scrambler 4x4	99 - 03	716 ATS*	755 ATS	
400 Scrambler L 4x4	95 - 97	716 ATS*	717 ATS	
400 Sport	99 - 00	716 ATS*	755 ATS	
400 Sport L	94 - 98	716 ATS*	717 ATS	
400 Sportsman	01 - 13	716 ATS*	755 ATS	
400 Sportsman L 4x4	94 - 97	716 ATS*	717 ATS	
400 Trail Blazer	03 - 04	716 ATS*	755 ATS	
400 Xplorer L 4x4	95 - 99	716 ATS*	717 ATS	
400 Xplorer L 4x4	00 - 02	716 ATS*	755 ATS	
400 Xpress L	96 - 97	716 ATS*	717 ATS	
425 2x4, 4x4 Magnum	95 - 98	716 ATS*	717 ATS	
425 Magnum 6x6	96 - 96	716 ATS*	717 ATS	
425 Magnum 6x6				
Middle Axle Brake	96 - 96	756 ATS		
425 Xpedition 4x4	00 - 03	716 ATS*	755 ATS	

**RECOMMENDED**1xx - 2xx = Scooter Pads  
5xx - 9xx = Street, Off Road & Racing Pads  
2xxx = Brake Shoes

POLARIS				
450 Outlaw MXR	09 - 11	898 ATS*	642 ATS	
450 Outlaw S	08 - 08	898 ATS*	642 ATS	
450 Sportsman	06 - 09	716 ATS*	787 ATS	
455 Diesel EBS 4x4	99 - 01	716 ATS*	755 ATS	
500 ATP HO	04 - 05	716 ATS*	716 ATS*	
500 Big Boss 6x6	98 - 99	716 ATS*	717 ATS	
500 Big Boss 6x6				
Middle Axle Brake	98 - 99	717 ATS		
500 E Scrambler 2x4, 4x4	08 - 11	642 ATS*	787 ATS	
500 Magnum 2x4, 4x4	02 - 07	716 ATS*	787 ATS	
500 Magnum 4x4	00 - 01	716 ATS*	755 ATS	
500 Outlaw	06 - 09	716 ATS*	716 ATS	
500 Predator	03 - 13	716 ATS*	716 ATS	
500 Predator e	06 - 13	716 ATS*	787 ATS	
500 Ranger 2x4	08 - 07	897 ATS*	800 ATS	
500 Ranger 2x4 EFI	08 - 13	897 ATS*	800 ATS	
500 Ranger 2x4, 4x4, 6x6	02 - 13	800 ATS*	800 ATS*	
500 Ranger 4x4	12 - 13	897 ATS*	800 ATS	
500 Ranger 6x6	00 - 02	716 ATS*		
500 Ranger XP	06 - 09	800 ATS*	800 ATS	
500 Revolver	06 - 06	642 ATS*	642 ATS	
500 Scrambler 2x4	01 - 02	716 ATS*	755 ATS	
500 Scrambler 4x4	97 - 97	716 ATS*	717 ATS	
500 Scrambler 4x4	98 - 13	716 ATS*	755 ATS	
500 Sportsman 4x4	96 - 14	716 ATS*	717 ATS	
500 Sportsman 6x6	00 - 11	716 ATS*	757 ATS	
500 Sportsman EBS 4x4	98 - 02	716 ATS*	755 ATS	
500 Sportsman HO				
(from 16.12.2008)	09 - 14	642 ATS*	899 ATS	
500 Sportsman HO				
(to 15.12.2008)	03 - 08	642 ATS*	787 ATS	
500 Xplorer 4x4	97 - 97	716 ATS*	717 ATS	
525 Outlaw	07 - 13	898 ATS*	642 ATS	
525 Outlaw IRS	08 - 13	898 ATS*	642 ATS	
525 Outlaw S	08 - 11	898 ATS*	642 ATS	
550 Sportsman	11 - 14	899 ATS*	899 ATS	
550 Sportsman EPS	10 - 14	899 ATS*	899 ATS	
550 Sportsman EPS X2	14 - 14	899 ATS*	899 ATS	
550 Sportsman Touring EPS	10 - 12	899 ATS*	899 ATS	
550 Sportsman X2	10 - 14	899 ATS*	899 ATS	
550 Sportsman XP	09 - 12	899 ATS*	899 ATS	
550 Sportsman XP EPS	09 - 14	899 ATS*	899 ATS	
550 Sportsman XP Touring				
EPS	12 - 14	899 ATS*	899 ATS	
570 Ranger RZR EFI	12 - 13	898 ATS*	642 ATS	
600 Sportsman	03 - 06	642 ATS*	787 ATS*	
700 MVRS 4x4	08 - 08	897 ATS*	897 ATS	
700 Ranger 4x4 EFI	08 - 08	897 ATS*	800 ATS	
700 Ranger 6x6 EFI	12 - 13	897 ATS*	800 ATS	
700 Sportsman	02 - 09	642 ATS*	787 ATS*	
700 Sportsman MV 700	05 - 06	642 ATS*	787 ATS	
800 MVRS 4x4	08 - 08	897 ATS*	897 ATS	
800 Ranger 4x4 EFI	10 - 10	897 ATS*	897 ATS	
800 Ranger 6x6 EFI	12 - 15	897 ATS*	897 ATS	
800 Ranger Crew	12 - 15	897 ATS*	897 ATS	
800 Ranger RZR EFI	08 - 14	898 ATS*	642 ATS	
800 Ranger RZR S EFI	09 - 15	898 ATS*	642 ATS	
800 Ranger RZR4 EFI	12 - 14	897 ATS*	800 ATS	
800 Ranger XP	12 - 13	897 ATS*	800 ATS	
800 RZR	08 - 15	898 ATS*	642 ATS	
800 RZR-4	10 - 14	897 ATS*	800 ATS	
800 Sportsman				
(from 16.12.2008)	09 - 14	642 ATS*	899 ATS	
800 Sportsman				
(to 15.12.2008)	05 - 08	642 ATS*	787 ATS	
850 Forest	15 - 15	899 ATS*	899 ATS	
850 Scrambler	15 - 15	899 ATS*	899 ATS	
850 Scrambler HO EPS	13 - 15	899 ATS*	899 ATS	

\* = 2 sets required / 2 jeux pour l'Avant.



**RECOMMENDED**

1xx - 2xx = Scooter Pads  
5xx - 9xx = Street, Off Road & Racing Pads  
2xxx = Brake Shoes



<b>POLARIS</b>			
850 Scrambler MD	15 - 15	899 ATS*	899 ATS
850 Scrambler XP HO EPS	14 - 15	899 ATS*	899 ATS
850 Sportsman	11 - 13	899 ATS*	899 ATS
850 Sportsman MV	12 - 12	899 ATS*	899 ATS
850 Sportsman Touring	14 - 15	899 ATS*	899 ATS
850 Sportsman Touring EPS	10 - 13	899 ATS*	899 ATS
850 Sportsman Touring HO			
EPS	13 - 14	899 ATS*	899 ATS
850 Sportsman Touring MD	15 - 15	899 ATS*	899 ATS
850 Sportsman X2	11 - 11	899 ATS*	899 ATS
850 Sportsman XP	09 - 14	899 ATS*	899 ATS
850 Sportsman XP EPS	09 - 14	899 ATS*	899 ATS
850 Sportsman XP HO EPS	13 - 14	899 ATS*	899 ATS
850 Sportsman XP HO EPS			
MD	15 - 15	899 ATS*	899 ATS
850 Sportsman XP Touring			
EPS	15 - 15	899 ATS*	899 ATS
900 Ranger 4x4 Diesel	10 - 14	897 ATS*	897 ATS
900 Ranger RZR4 XP EFi	12 - 15	897 ATS*	897 ATS
900 Ranger RZR4 XP4 EFi	12 - 14	897 ATS*	897 ATS
RZR	900 50/55/60 Inch	15 - 20	970 PSI* 898 PSI
RZR-S	900 60 Inch	20 - 20	970 PSI* 898 PSI
	925 RZR XP Turbo	16 - 19	954 SI* 897 SI
	925 RZR XP Turbo	20 - 20	954 SI* 978 SI*
	925 RZR XP4 Turbo	16 - 19	954 SI* 897 SI
	925 RZR XP4 Turbo	20 - 20	954 SI* 978 SI*
	925 RZR XP4 Turbo S	19 - 20	977 SI* 897 SI*
	925 RZR XP4 Turbo S		
	Velocity	19 - 20	977 SI* 897 SI*
	1000 Forest	15 - 15	899 ATS* 899 ATS
	1000 General EPS	16 - 18	897 ATS* 898 ATS
	1000 Ranger RZR XP	14 - 14	897 ATS* 897 ATS
	1000 Scrambler MD	15 - 18	899 ATS* 899 ATS
	1000 Scrambler XP	15 - 18	899 ATS* 899 ATS
	1000 Scrambler XP HO EPS	14 - 14	899 ATS* 899 ATS
	1000 Sportsman MD	15 - 18	899 ATS* 899 ATS
	1000 Sportsman Touring	15 - 18	899 ATS* 899 ATS
	1000 Sportsman XP	15 - 18	899 ATS* 899 ATS
RZR	1000 60 Inch	16 - 20	970 PSI* 898 PSI
RZR-S	1000 60 Inch	20 - 20	970 PSI* 898 PSI
	1050 MV Diesel Crew	13 - 18	897 ATS* 897 ATS
<b>POLINI</b>			
X1	50 R	04 - 06	794 RSI 794 RSI
X3	50 R	04 - 06	794 RSI 794 RSI
X5	65 RP	05 - 06	794 RSI 794 RSI
<b>REWACO</b>			
	FX4	07 - 07	519 HF
	FX5	07 - 07	519 HF
	FX6	07 - 07	519 HF
	HS4	01 - 01	519 HF
	HS5	01 - 01	519 HF
	HS6	01 - 01	519 HF
	RF1	07 - 14	519 HF
<b>ROYAL ENFIELD</b>			
	411 Himalayan	19 - 20	671 HF 675 HF
	500 Bullet	20 - 20	671 HS 675 LS
	500 Bullet Trials	20 - 20	671 HS 675 LS
	500 Classic	19 - 19	671 HF 675 HF
	535 Continental GT	14 - 17	674 HS 675 LS
	650 Continental GT	20 - 20	674 HS 675 LS
	650 Interceptor	19 - 20	674 HS 675 LS
<b>SACHS</b>			
	50 MadAss	04 - 05	200 HF
	50 MadAss 4T	05 - 09	200 HF 100 HF



**RECOMMENDED**

1xx - 2xx = Scooter Pads  
5xx - 9xx = Street, Off Road & Racing Pads  
2xxx = Brake Shoes



<b>SACHS</b>			
	125 MadAss	09 - 09	200 HF 100 HF
	500 MadAss	05 - 08	566 HF* 684 HF
<b>SCORPA</b>			
SY	115 F Trial	06 - 06	802 RSI 803 RSI
TY-S	115 F Trial	06 - 06	559 HF 803 RSI
	125 Twenty Trial	16 - 18	802 RSI 803 RSI
SY	125 F Trial	06 - 11	802 RSI 803 RSI
TY-S	125 F Trial	06 - 08	559 HF 803 RSI
	250 T-Ride	08 - 11	859 HF 773 HF
	250 Twenty Trial	16 - 18	802 RSI 803 RSI
SY	250 F Trial	06 - 11	802 RSI 803 RSI
SY	250 Trial	00 - 01	802 RSI 803 RSI
	300 Twenty Trial	16 - 18	802 RSI 803 RSI
<b>SHERCO</b>			
	50 AJP Caliper		
	incl. pin/spring	91 - 19	188 HF
	80 0,8	01 - 03	559 HF 559 HF
ST	80 (Formula cal.)	13 - 14	885 RSI 803 RSI
SE-R	125	17 - 19	671 SI 791 SI
ST	125 (Formula cal.)	13 - 14	885 RSI 803 RSI
ST	125 1,25	01 - 05	559 HF 559 HF
ST	125 1,25	06 - 11	802 RSI 803 RSI
ST	200 2	01 - 01	559 HF 559 HF
SE	250 , R	14 - 14	671 SI 791 SI
SE	250 2.5i Enduro	06 - 11	671 SI 790 SI
SE	250 F, F-R	14 - 19	671 SI 791 SI
SE	250 i/iR	12 - 13	671 SI 791 SI
SE	250 i-F	13 - 13	671 SI 791 SI
ST	250	99 - 00	559 RSI 559 RSI
ST	250 (Formula cal.)	13 - 14	885 RSI 803 RSI
ST	250 2,5	01 - 01	802 RSI 803 RSI
SX	250 2.5i-F	09 - 11	671 RSI 790 RSI
ST	290 (Formula cal.)	13 - 14	885 RSI 803 RSI
ST	290 2,9	01 - 01	802 RSI 803 RSI
SCF-R	300	16 - 19	671 SI 791 SI
SE	300 , R	14 - 19	671 SI 791 SI
SE	300 3.0i-F	10 - 11	671 SI 790 SI
SE	300 F, F-R	14 - 19	671 SI 791 SI
SE	300 i/iR	12 - 13	671 SI 791 SI
SE	300 i-F	13 - 13	671 SI 791 SI
ST	300	16 - 19	802 RSI 803 RSI
ST	305 (Formula cal.)	13 - 14	885 RSI 803 RSI
ST	320 3.2F	05 - 05	802 RSI 803 RSI
SE	450 4.5i Enduro	04 - 04	671 SI 604 SI
SE	450 4.5i Enduro	05 - 11	671 SI 790 SI
SE	450 F, F-R	14 - 19	671 SI 791 SI
SE	450 iR	12 - 13	671 SI 791 SI
SM	450 4.5i Supermotard	06 - 06	762 RST 790 RSI
SE	510 5.1i Enduro	06 - 11	671 SI 790 SI
SE	510 iR	12 - 13	671 SI 791 SI
<b>SUZUKI</b>			
RE	5M, A	75 - 77	503 HF 2098
	50 AJP Caliper		
	incl. pin/spring	91 - 19	188 HF
AH	50 Adress	92 - 95	101 HF 2181
ALT	50	83 - 84	2020
DR-Z	50	19 - 21	2010 2010
FA	50	80 - 91	2101 2101
GSXR	50	87 - 87	135 HF 2017
JR	50	89 - 07	2020 2020
LT	50	84 - 02	2020
LT-A	50 Quadmaster	01 - 05	2101 2017
LT-Z	50 Quadspport	06 - 20	2101* 2017
OR	50	79 - 79	2015 2015
OR	50	80 - 80	2017 2017

\* = 2 sets required / 2 jeux pour l'Avant.

Full compound selection, see under "Brake pad 1:1 Drawings" / Sélection complète de composés, voir "1:1 Schémas Plaquettes de frein".

**RECOMMENDED**1xx - 2xx = Scooter Pads  
5xx - 9xx = Street, Off Road & Racing Pads  
2xxx = Brake Shoes

SUZUKI					
OR	50 E	80 - 80	135 HF	2017	
RG	50 GAG	87 - 92	135 HF	2103	
RG	50 Gamma	90 - 96	135 HF	2103	
ZR	50	81 - 87	135 HF	2017	
ZZ	50 Scooter	92 - 92	101 HF	2181	
RM	60	03 - 03	2093	2093	
RM	65	03 - 06	752 RSI	536 RSI	
DR-Z	70	08 - 20	2010	2010	
AH	80 Adress, V, Tune	88 - 91	101 HF	2181	
AH	80 Scooter	92 - 94	102 HF	2181	
DS	80	80 - 96	2017	2017	
JR	80	01 - 07	2017	2017	
LT	80	87 - 06	2101*	2104	
RM	80	77 - 79	2015	2015	
RM	80	80 - 81	2017	2017	
RM	80	82 - 82	2022	2182	
RM	80	83 - 85	2014	2017	
RM	80	86 - 89	548 HF	2182	
RM	80	90 - 95	548 HF	544 SI	
RM	80	96 - 01	702 RSI	544 RSI	
RM	85	02 - 04	702 RSI	544 RSI	
RM	85	05 - 21	726 RSI	820 RSI	
LT-Z	90 QuadSport	07 - 20	2017*	2104	
RV	90	73 - 81	2015	2015	
TS	90	71 - 73	2015	2014	
AH	100 V Adress	91 - 94	101 HF	2181	
DR	100	83 - 90	2017	2017	
RM	100	76 - 78	2015	2014	
RM	100	79 - 81	2015	2103	
RM	100	03 - 03	726 RSI	592 RSI	
	110 Smash	03 - 06	2015	2015	
DR-Z	110	02 - 06	2093	2015	
FX	110 Shogun	98 - 02	2015	2015	
UK	110 Adress	15 - 19	122 HF	2181	
ALT	125	84 - 86		2016	
ALT	125 D	83 - 83		2107	
DR	125	82 - 84	2014	2014	
DR	125	86 - 02	536 HF	2014	
DR-Z	125 K	03 - 12	2017	2017	
DR-Z	125 L	03 - 20	702 SI	2017	
GN	125	91 - 04	546 HF	2014	
GS	125 ESD	83 - 94	585 HF	2014	
GSX-R	125 RL	17 - 21	951 HF	915 HF	
GSX-R	125 RLX	17 - 21	951 HF	915 HF	
GSX-S	125 ML	17 - 19	951 HF	915 HF	
GSX-S	125 MLX	17 - 19	951 HF	915 HF	
GT	125	75 - 77	503 HF	2014	
GT	125	78 - 79	515 HF	2014	
GT	125	80 - 82	546 HF	2014	
LT	125 D	83 - 83		2107	
LT	125 E-H	84 - 87		2016	
RH	125 X	87 - 87	536 HF		
RM	125	75 - 78	2014	2014	
RM	125	79 - 80	2014	2103	
RM	125	81 - 83	2014	2102	
RM	125	84 - 84	2108	2102	
RM	125	85 - 86	581 HF	2102	
RM	125	87 - 87	611 SI	2102	
RM	125	88 - 88	611 RSI	584 RSI	
RM	125	89 - 90	611 RSI	632 RSI	
RM	125	91 - 95	611 RSI	648 RSI	
RM	125	96 - 09	694 RSI	604 RSI	
RV	125 VanVan	03 - 18	704 HF		
SP	125	82 - 83	2014	2014	
SP	125	86 - 88	536 HF	2014	
TS	125	72 - 72	2015	2014	
TS	125	82 - 82	2014	2017	
TS	125	84 - 84	2014		

**RECOMMENDED**1xx - 2xx = Scooter Pads  
5xx - 9xx = Street, Off Road & Racing Pads  
2xxx = Brake Shoes

SUZUKI					
TS	125	85 - 86	536 HF	2103	
TS	125	89 - 96	611 HF	632 HF	
UC	125 Epicuro	99 - 02	122 CT	2202	
UE	125	01 - 03	101 CT		
UH	125 Burgman	07 - 14	192 CT	196 CT	
UE	150 CT	02 - 03	101 CT		
LT	160	89 - 92	2181*	2016	
LT-F	160	91 - 04	2181*	2016	
PE	175	82 - 82	2104		
ALT	185	85 - 87		2016	
GT	185	75 - 77	503 HF	2014	
LT	185	84 - 87		2016	
TS	185	74 - 81	2014	2014	
DR	200	86 - 88	536 SI	2014	
DR	200 S	15 - 17	536 SI	2014	
DR	200 SE	96 - 13	536 SI	2014	
DR	200 T	96 - 96	536 SI	2014	
RV	200 VanVan	16 - 19	704 HF		
SP	200	86 - 88	536 HF	2014	
UH	200	07 - 07	192 CT		
UH	200 Burgman	07 - 13	192 CT	196 CT	
UH	200 Burgman	14 - 18	134 CT	196 CT	
LT	230	86 - 93	591 SI*	592 SI	
LT-F	230	86 - 87	2051*	2016	
AN	250 Burgman	98 - 03	146 MS	104 MS	
AN	250 Burgman	04 - 06	146 MS	174 MS	
DL	250 V-Strom	17 - 19	627 HF	657 HF	
DR	250	82 - 83	2014	2014	
DR	250	85 - 89	536 HF	2014	
DR	250	90 - 95	611 HF	632 HF	
DR-Z	250	01 - 07	694 SI	648 SI	
GN	250	86 - 97	533 HF	2014	
GS	250	80 - 82	533 HF	2018	
GT	250	73 - 77	503 HF	2097	
GT	250	78 - 81	515 HF	2018	
GW	250 Inazuma	12 - 19	627 HS	657 LS	
GW	250 Inazuma F	15 - 19	627 HS	881 LS	
LT	250	85 - 86	2051*	2098	
LT	250	85 - 87	591 SI*	584 SI	
LT	250	88 - 94	591 SI*	649 SI	
LT	250	89 - 90	591 SI*	592 SI	
LT	250 4WD	87 - 98	2053*	2110	
LT-F	250	88 - 01	2053*	2110	
LT-F	250 4WD V, W Quadrunner	97 - 98	2053*	2098	
LT-F	250 Ozark	03 - 13	536 SI*		
LT-Z	250 Quad Sport	04 - 11	536 SI*		
RH	250	85 - 87	536 HF		
RM	250	76 - 78	2014	2016	
RM	250	79 - 79	2016		
RM	250	80 - 80	2104		
RM	250	81 - 82	2107	2102	
RM	250	83 - 83	2108	2102	
RM	250	84 - 84	2108	2104	
RM	250	85 - 85	581 HF	2104	
RM	250	86 - 86	582 HF	2104	
RM	250	87 - 88	611 RSI	584 RSI	
RM	250	89 - 90	611 RSI	632 RSI	
RM	250	91 - 95	611 RSI	648 RSI	
RM	250	96 - 09	694 RSI	604 RSI	
RMX	250	89 - 95	611 RSI	648 RSI	
RMX	250	96 - 98	694 RSI	648 RSI	
RMX	250 X-K1	99 - 99	694 SI	604 SI	
RM-Z	250	04 - 22	694 RSI	790 RSI	
SP	250	85 - 85	536 HF	2014	
TS	250	74 - 82	2016	2016	
TU	250 X	09 - 19	705 HF		
LT-F	280 4WD	91 - 98		2052	
GS	300	82 - 85		2018	

\* = 2 sets required / 2 jeux pour l'Avant.



**RECOMMENDED**

1xx - 2xx = Scooter Pads  
5xx - 9xx = Street, Off Road & Racing Pads  
2xxx = Brake Shoes



SUZUKI				
LT	300	87 - 89	2051*	2098
LT-F	300	88 - 90	2051	2052
LT-F	300 King Quad	91 - 01		2052
LT-F	300 King Quad Left	02 - 02	611 SI	
LT-F	300 King Quad Right	02 - 02	638 SI	
DR	350	90 - 99	611 HF	648 HF
DR	350 V, W, X	97 - 99	694 SI	648 SI
SP	370	77 - 79	2016	2016
GT	380	73 - 77	503 HF	2097
GT	380 Asco	77 - 77	515 HF	2097
AN	400 Burgman	99 - 00	146 MS	104 MS
AN	400 Burgman	01 - 06	146 MS	174 MS
DR-Z	400 S/E	00 - 12	694 HF	604 HF
DR-Z	400 SM	05 - 10	694 RSI	604 RSI
GN	400	80 - 80	533 HF	2018
GS	400	77 - 78	511 HF	2097
GS	400	79 - 82	515 HF	2097
GSF	400 Bandit	91 - 92	597 HS*	556 LS
GSF	400 Bandit	93 - 97	631 HS*	556 LS
KLT-A	400 King Quad Left	08 - 14	835 SI	
KLT-A	400 King Quad Right	08 - 14	836 SI	
KLT-F	400 King Quad Left	08 - 14	835 SI	
KLT-F	400 King Quad Right	08 - 14	836 SI	
LT-A	400 Eiger 2WD/4WD	02 - 07	536 SI*	2018
LT-A	400 King Quad Left	08 - 14	835 SI	
LT-A	400 King Quad Right	08 - 14	836 SI	
LT-F	400 Eiger 2WD/4WD	02 - 07	536 SI*	2018
LT-F	400 King Quad Left	08 - 14	835 SI	
LT-F	400 King Quad Right	08 - 14	836 SI	
LT-Z	400 Quad Sport	02 - 19	592 SI*	649 SI
PE	400	79 - 81	2016	2016
RM	400	78 - 78	2014	2016
RM	400	79 - 79	2016	
RM	400	80 - 80	2104	
SP	400	80 - 82	2016	2016
GS	425	79 - 79	511 HF	2018
GS	425	80 - 80	515 HF	2018
GS	450	80 - 83	533 HF	2018
GS	450	85 - 85	534 HF	2018
GS	450	86 - 86	546 HF*	512 HF
GS	450	90 - 90	597 HS	597 LS
LT-A	450 King Quad Left	08 - 14	835 SI	
LT-A	450 King Quad Right	08 - 14	836 SI	
LT-R	450 Left	06 - 12	611 SI	649 SI
LT-R	450 Right	06 - 12	638 SI	
RMX	450 Z	10 - 18	694 SI	790 SI
RM-Z	450	05 - 22	694 RSI	790 RSI
RM	465	81 - 82	2107	2014
GS	500 F	04 - 08	704 HS	556 HF
GT	500	73 - 75	515 HF	2098
GT	500	75 - 77	503 HF	2098
LT	500	87 - 95	591 SI*	649 SI
LT-A	500 F Vinson	02 - 02	536 SI*	
LT-A	500 FY Quadmaster Left	00 - 08	611 SI	
LT-A	500 FY Quadmaster Right	00 - 08	638 SI	
LT-A	500 King Quad Left	11 - 14	835 SI	
LT-A	500 King Quad Right	11 - 14	836 SI	
LT-F	500 F Left	98 - 07	638 SI	
LT-F	500 F Right	98 - 07	611 SI	
RM	500	83 - 84	2108	2014
RM	500	85 - 87	581 HF	2014
RM	500	88 - 89	611 RSI	592 RSI
GS	550	77 - 77	515 HF*	2099
GS	550	78 - 79	515 HF*	
GS	550	80 - 82	534 HF*	512 HF
GS	550	83 - 86	556 HF	556 HF
GT	550	73 - 77	503 HF	2098
GT	550	78 - 78	515 HF	2099



**RECOMMENDED**

1xx - 2xx = Scooter Pads  
5xx - 9xx = Street, Off Road & Racing Pads  
2xxx = Brake Shoes



SUZUKI				
GSF	600 Bandit	95 - 99	627 HS*	556 LS
GSF	600 Bandit / S Bandit Left	00 - 04	705 HS	556 LS
GSF	600 Bandit / S Bandit Right	00 - 04	704 HS	
GSR	600	06 - 10	631 HS*	833 LS
GSX	600 FW Left	98 - 04	705 HS	556 LS
GSX	600 FW Right	98 - 04	704 HS	
GSX	600 Katana	88 - 89	620 HF*	556 HF
GSX	600 Katana	90 - 97	620 HS*	556 LS
GSX-R	600	92 - 93	624 HS*	556 LS
GSX-R	600	97 - 03	631 HS*	556 LS
GSX-R	600	04 - 05	806 HS*	765 LS
GSX-R	600	06 - 10	806 HS*	833 LS
GSX-R	600	11 - 21	841 HS*	834 LS
RF	600 R	93 - 96	627 HS*	556 LS
SP	600 F	85 - 87	582 HF	2014
AN	650 A Burgman Executive	04 - 20	183 MS*	182 MS
AN	650 Burgman	02 - 19	183 MS*	182 MS
AN	650 Z Burgman Executive	13 - 19	183 MS*	182 MS
DL	650 V-Strom Left	04 - 20	705 HS	657 LS
DL	650 V-Strom Right	04 - 20	704 HS	
DL	650 V-Strom XT	15 - 20	705 HS	657 LS
DL	650 V-Strom XT Right	15 - 20	704 HS	
DR	650	90 - 95	626 HS	635 LS
DR	650 R	92 - 92	626 HS	635 LS
DR	650 SE T-W	96 - 99	694 HF	648 HF
GR	650	83 - 84	534 HF*	512 HF
GR	650 X	83 - 84	534 HF	2018
GS	650	81 - 83	534 HF*	512 HF
GS	650 G	83 - 87	534 HF*	512 HF
GS	650 Turbo, XN	83 - 85	534 HF*	512 HF
GSF	650 Bandit	07 - 11	631 HS*	657 LS
GSF	650 Bandit / S Bandit Left	05 - 05	705 HS	765 LS
GSF	650 Bandit / S Bandit Right	05 - 05	704 HS	
GSF	650 Bandit / S Bandit ABS			
	Left	06 - 06	705 HS	657 LS
GSF	650 Bandit / S Bandit ABS			
	Right	06 - 06	704 HS	
GSF	650 Bandit ABS	07 - 12	631 HS*	657 LS
GSF	650 S Bandit	07 - 11	631 HS*	657 LS
GSF	650 S Bandit ABS	07 - 13	631 HS*	657 LS
GSX	650 F	08 - 18	631 HS*	657 HF
LS	650 P	86 - 88	581 HF	2018
LS	650 P Savage	95 - 04	581 HF	2018
S40	650 Boulevard	05 - 18	581 HF	2018
SFV	650 Gladius Left	09 - 16	705 HS	881 LS
SFV	650 Gladius Right	09 - 16	704 HS	
SV	650 Left	16 - 18	705 HS	881 LS
SV	650 Right	16 - 18	704 HS	
SV	650	19 - 20	631 HS*	881 LS
SV	650 ,S Left	99 - 02	704 HS	
SV	650 ,S Right	99 - 02	705 HS	556 LS
SV	650 ,S Left	03 - 12	705 HS	657 LS
SV	650 ,S Right	03 - 12	704 HS	
SV	650 ,S ABS	07 - 18	705 HS	657 LS
SV	650 X Left	18 - 18	705 HS	881 LS
SV	650 X Right	18 - 18	704 HS	
SV	650 X	19 - 20	631 HS*	881 LS
GS	700	85 - 85	533 HF*	512 HF
GV	700 GLG Madura	86 - 86	533 HF*	2052
LT-A	700 King Quad Left	05 - 11	835 SI	
LT-A	700 King Quad Right	05 - 11	836 SI	
LT-V	700 Quadranner Twin Peaks			
	Left	04 - 06	801 SI	
LT-V	700 Quadranner Twin Peaks			
	Right	04 - 06	798 SI	
VS	700 GLFG	86 - 87	577 HF	2052
GS	750	76 - 77	511 HF	512 HF
GS	750	78 - 79	515 HF*	512 HF

\* = 2 sets required / 2 jeux pour l'Avant.

Full compound selection, see under "Brake pad 1:1 Drawings" / Sélection complète de composés, voir "1:1 Schémas Plaquettes de frein".

**RECOMMENDED**1xx - 2xx = Scooter Pads  
5xx - 9xx = Street, Off Road & Racing Pads  
2xxx = Brake Shoes

SUZUKI					
GS	750 D	77 - 79	511 HF*	512 HF	
GS	750 E	77 - 79	511 HF*	512 HF	
GS	750 Katana	85 - 86	556 HF*	556 HF	
GS	750 RF	85 - 85	577 HF*	556 HF	
GS	750 SD	83 - 83	534 HF*	512 HF	
GSR	750 Left	11 - 16	705 HS	657 LS	
GSR	750 Right	11 - 16	704 HS		
GSX	750 Left	98 - 08	705 HS	556 LS	
GSX	750 Right	98 - 08	704 HS		
GSX	750 FW Left	98 - 02	705 HS	556 LS	
GSX	750 FW Right	98 - 02	704 HS		
GSX	750 Katana	89 - 96	620 HS*	556 LS	
GSX-R	750	85 - 87	577 HF*	556 HF	
GSX-R	750	88 - 93	624 HS*	556 LS	
GSX-R	750	94 - 99	686 HS*	556 LS	
GSX-R	750	00 - 03	631 HS*	556 LS	
GSX-R	750	04 - 05	806 HS*	765 LS	
GSX-R	750	06 - 10	806 HS*	833 LS	
GSX-R	750	11 - 18	841 HS*	834 LS	
GSX-S	750 Left	15 - 16	705 HS	657 LS	
GSX-S	750 Right	15 - 16	704 HS		
GSX-S	750	17 - 19	782 HS*	657 LS	
GSX-S	750 Z Left	15 - 16	705 HS	657 LS	
GSX-S	750 Z Right	15 - 16	704 HS		
GT	750	73 - 77	503 HF*	2098	
LT-A	750 King Quad Left	08 - 14	835 SI		
LT-A	750 King Quad Right	08 - 14	836 SI		
VS	750 Intruder	86 - 91	577 HF*	2052	
C50	800 Boulevard	05 - 18	704 HS	2052	
M50	800 Boulevard	05 - 18	704 HS	2052	
S50	800 Boulevard	05 - 18	577 HS	2052	
VL	800 Intruder LC Volusia	01 - 04	704 HS	2052	
VS	800 Intruder	91 - 99	577 HS	2052	
VX	800 L-P	90 - 93	597 HS	620 LS	
VZ	800 Marauder	97 - 04	704 HS	2052	
GS	850	79 - 80	511 HF*	512 HF	
GS	850	81 - 82	533 HF*	512 HF	
GS	850 G	83 - 86	533 HF*	512 HF	
RF	900 RR,RS,RS2,T,V	94 - 97	714 HS*	701 LS	
GSX-S	950	22 - 22	806 SP*	657 LS	
DL	1000 V-Strom Left	02 - 13	705 HS	657 LS	
DL	1000 V-Strom Right	02 - 13	704 HS		
DL	1000 V-Strom	14 - 19	806 SP*	833 LS	
DL	1000 V-Strom XT	17 - 19	806 SP*	833 LS	
DL	1000 V-Strom XT Adventure	19 - 19	806 SP*	833 LS	
G	1000 SZ	82 - 82	534 HF*	512 HF	
GS	1000	78 - 79	515 HF*	512 HF	
GS	1000	80 - 81	533 HF*	512 HF	
GS	1000 ET	81 - 81	534 HF*	512 HF	
GS	1000 EX	81 - 81	534 HF*	512 HF	
GSX-R	1000	01 - 02	686 HS*	765 LS	
GSX-R	1000	03 - 03	788 HS*	765 LS	
GSX-R	1000	04 - 06	806 HS*	765 LS	
GSX-R	1000	07 - 08	806 HS*	833 LS	
GSX-R	1000	09 - 11	806 SP*	834 LS	
GSX-R	1000	12 - 22	841 SP*	834 LS	
GSX-R	1000 R	17 - 22	841 SP*	834 LS	
GSX-S	1000	15 - 19	841 HS*	657 LS	
GSX-S	1000 F	15 - 19	841 HS*	657 LS	
GSX-S	1000 Katana	19 - 21	841 HS*	657 LS	
SV	1000 ,S	03 - 07	631 HS*	657 LS	
TL	1000 RW	98 - 02	686 HS*	556 LS	
TL	1000 S V-Twin	97 - 01	631 HS*	556 LS	
DL	1050 V-Strom	20 - 20	806 SP*	833 LS	
DL	1050 V-Strom XT	20 - 20	806 SP*	833 LS	
GS	1100	81 - 81	534 HF*	512 HF	
GS	1100	82 - 83	533 HF	512 HF	
GS	1100 ED, ESD, GD	83 - 83	534 HF*	512 HF	

**RECOMMENDED**1xx - 2xx = Scooter Pads  
5xx - 9xx = Street, Off Road & Racing Pads  
2xxx = Brake Shoes

SUZUKI					
GS	1100 G	86 - 88	534 HF*	512 HF	
GS	1100 GKD, SD, GLD	83 - 83	534 HF*	512 HF	
GS	1100 L	79 - 79	534 HF*	512 HF	
GSX	1100 F	93 - 96	620 HS*	556 LS	
GSX	1100 G	94 - 95	597 HS*	615 LS	
GSX	1100 G Left	96 - 98	705 HS	556 LS	
GSX	1100 G Right	96 - 98	704 HS		
GSX	1100 Katana	93 - 93	624 HS*	556 LS	
GSX-R	1100	86 - 88	577 HF*	556 HF	
GSX-R	1100	89 - 92	624 HS*	556 LS	
GSX-R	1100	93 - 97	686 HS*	556 LS	
GT	1100	80 - 80	534 HF*	512 HF	
GS	1150 EG	86 - 87	577 HF*	577 HF	
GS	1150 ES	84 - 85	577 HF*	577 HF	
GSF	1200 Bandit	95 - 96	624 HS*	556 LS	
GSF	1200 Bandit	97 - 00	714 HS*	556 LS	
GSF	1200 Bandit	01 - 05	686 HS*	556 LS	
GSF	1200 S Bandit	01 - 05	686 HS*	556 LS	
GSF	1200 S Bandit	06 - 06	631 HS*	657 LS	
GV	1200 GLG Madura	86 - 86	533 HF*	512 HF	
GSF	1250 A Bandit	07 - 18	631 HS*	657 LS	
GSF	1250 Bandit	06 - 18	631 HS*	657 LS	
GSF	1250 F Bandit	12 - 18	631 HS*	657 LS	
GSF	1250 S Bandit	06 - 18	631 HS*	657 LS	
GSF	1250 SA Bandit	07 - 18	631 HS*	657 LS	
GSX	1250 FA Bandit	16 - 18	631 HS*	657 LS	
GSX	1250 FA Traveller	15 - 16	631 HS*	657 LS	
	1300 B-King	07 - 07	838 HS*	657 LS	
GSX-R	1300 Hayabusa	99 - 07	686 HS*	556 LS	
GSX-R	1300 Hayabusa	08 - 12	806 HS*	833 LS	
GSX-R	1300 Hayabusa	13 - 21	841 HS*	833 LS	
	1340 B-King	08 - 14	782 HS*	833 LS	
GL	1400 Cavalcade	87 - 88	620 HF*	577 HF	
GSX	1400	02 - 07	686 HS*	765 LS	
GV	1400 Cavalcade	85 - 86	534 HF*	512 HF	
GV	1400 Cavalcade LXE	87 - 90	577 HS*	577 LS	
S83	1400 Boulevard	05 - 10	577 HS	577 LS	
C	1500 T Intruder	13 - 18	627 HS	886 LS	
C90	1500 Boulevard Left	05 - 18	705 HS	789 LS	
C90	1500 Boulevard Right	05 - 18	704 HS		
C90	1500 Boulevard B.O.S.S.	13 - 18	627 HS	886 LS	
M90	1500 Left	09 - 18	705 HS	886 LS	
M90	1500 Right	09 - 18	704 HS		
VL	1500 Intruder LC	98 - 01	577 HS	577 LS	
VL	1500 Intruder LC Left	02 - 02	705 HS	789 LS	
VL	1500 Intruder LC Right	02 - 02	704 HS		
M95	1600 Boulevard	05 - 07	788 HS*	886 LS	
VZ	1600 Marauder	04 - 04	686 HS*	886 LS	
C109R	1800	08 - 12	828 HS*	920 LS	
M	1800 R Intruder	06 - 16	806 HS*	920 LS	
M109R	1800	06 - 18	806 HS*	920 LS	
M109R	1800 BOSS	14 - 14	806 HS*	920 LS	
M109R2	1800	08 - 16	806 HS*	920 LS	
SWM					
	125 Ace of Spades	20 - 20	873 HF		
	125 Gran Milano Outlaw	20 - 20	873 HF	791 HF	
	125 Outlaw	20 - 20	873 HF		
	125 Varez	20 - 20	873 HF	791 HF	
RS	125 R	20 - 20	873 HF	791 HF	
SM	125 R	20 - 20	873 HF	791 HF	
RS	300 R	15 - 20	671 SI	791 SI	
	400 Varez	20 - 20	900 HS	791 HF	
	440 Gran Milano	15 - 17	627 HS		
	440 Gran Milano	18 - 18	762 HS		
	440 Gran Turismo	15 - 17	627 HS		
	440 Silver Vase	15 - 17	627 HS		

\* = 2 sets required / 2 jeux pour l'Avant.





**RECOMMENDED**

1xx - 2xx = Scooter Pads  
5xx - 9xx = Street, Off Road & Racing Pads  
2xxx = Brake Shoes



SWM				
SM	450 R	15 - 17	762 HS	791 HF
	500 Ace of Spades	20 - 20	762 HS	791 HF
	500 Gran Milano Outlaw	20 - 20	762 HS	791 HF
RS	500 R	15 - 20	671 SI	791 SI
SM	500 R	18 - 20	762 HS	791 HF
	600 Superdual GT Pack	18 - 18	674 HS	675 LS
	600 Superdual T	18 - 20	674 HS	675 LS
	600 Superdual X	18 - 20	674 HS	675 LS
	650 Superdual	15 - 18	762 HS	675 LS
SYM				
	50 Allo	11 - 15	140 HF	
	50 Bullet	93 - 93	110 HF	
	50 Cinderella	01 - 00	110 HF	
	50 Crox	14 - 15	140 CT	
	50 Feel-big	98 - 98	618 HF	
	50 Fiddle	09 - 14	140 HF	2012
	50 Fiddle III	16 - 19	140 CT	202 CT
	50 Jet 4 Naked	11 - 13	140 HF	
	50 Jet 4 R	11 - 13	140 HF	
	50 Jet BasiX	07 - 09	140 HF	
	50 Jet Euro X	05 - 12	140 HF	
	50 Jet Sport X	06 - 14	140 HF	
	50 Jet Sport X SR	06 - 14	140 HF	129 HF
	50 Jet, Alpha	95 - 97	140 HF	2012
	50 Jungle	96 - 02	140 HF	2012
	50 Mask	00 - 05	140 HF	2012
	50 Mask LC	00 - 05	140 HF	2012
	50 Mio	05 - 16	110 HF	2057
	50 Orbit II	12 - 13	140 HF	
	50 Pure	98 - 98	618 HF	
	50 Red Devil	97 - 09	140 HF	2012
	50 Super Fancy	95 - 97	140 HF	2012
	50 Super Fancy	98 - 06	115 HF	
	50 Symphony	09 - 15	140 HF	
	50 Symphony SR	11 - 15	140 HF	
	50 Symphony ST	15 - 15	140 CT	
	50 Symply	08 - 14	140 HF	
	50 X'Pro	13 - 17	140 HF	
DD	50	02 - 12	110 HF	2057
RS	50	05 - 09	178 HF	2012
RS21	50	02 - 09	178 HF	
	100 Cinderella	01 - 01	110 HF	
	100 Jet	00 - 00	140 HF	
	100 Jet Euro X	05 - 05	140 HF	
	100 Jet Sport X	05 - 05	140 HF	
	100 Mio	05 - 16	110 HF	
	100 Party	97 - 00	140 HF	
	100 Super Fancy	95 - 00	140 HF	2012
	110 Bullet	93 - 93	542 HF	
	110 Star	03 - 03	140 HF	
	125 Aero Wolf	02 - 02	542 HF	
	125 Allo	11 - 15	140 CT	
	125 Attila	95 - 02	708 HF	2012
	125 Citycom	09 - 14	140 CT	
	125 Crox	14 - 15	140 CT	
	125 Euro MX	03 - 04	178 CT	
	125 Fiddle	09 - 16	140 CT	
	125 Fiddle III	16 - 19	140 CT	202 CT
	125 GTS	07 - 11	146 CT	
	125 Husky	96 - 98	135 CT	2188
	125 Husky	99 - 05	150 CT	
	125 Jet 14	17 - 19	140 CT	202 CT
	125 Jet 4	11 - 13	140 HF	
	125 Joymax Sport	16 - 16	146 CT	201 CT
	125 Joyride	01 - 06	178 CT	154 CT
	125 Joyride	07 - 09	178 CT	201 CT
	125 Joyride Evo	10 - 12	178 CT	201 CT



**RECOMMENDED**

1xx - 2xx = Scooter Pads  
5xx - 9xx = Street, Off Road & Racing Pads  
2xxx = Brake Shoes



SYM				
	125 Joyride S	16 - 17	178 CT	201 CT
	125 Megalo	02 - 05	140 CT	
	125 New Duke	02 - 07	140 CT	
	125 Super Duke	95 - 01	140 CT	2188
	125 Symphony	09 - 15	140 CT	
	125 Symphony EX	17 - 17	140 CT	
	125 Symphony S	11 - 17	140 CT	202 CT
	125 Symphony SR	11 - 17	140 CT	202 CT
	125 Symphony ST	15 - 19	140 CT	202 CT
	125 Symply	08 - 14	140 CT	
	125 Voyager	05 - 05	171 CT	
	125 Wolf Classic	05 - 05	551 HF	
	125 Wolf Legend	02 - 05	103 CT	
	125 X'Pro	14 - 16	140 CT	
HD	125	04 - 10	154 CT	
HD	125 Evo DT	10 - 10	140 CT	201 CT
HD2	125 Evo	14 - 14	140 CT	201 CT
NH	125 T	19 - 19	663 HF	
NH	125 X	19 - 19	663 HF	
RS	125	05 - 06	178 CT	119 CT
RS21	125 , R	02 - 02	178 CT	
SB	125 Wolf Ni	11 - 13	847 HF	810 HF
VS	125	07 - 08	792 HF	
VS	125	09 - 13	178 CT	
	150 Attila	00 - 03	140 CT	
	150 Crox	14 - 16	140 CT	
	150 Euro MX	03 - 06	178 CT	
	150 Husky	99 - 02	150 CT	2188
	150 Husky ADV	22 - 22	178 CT	
	150 Jet 4	11 - 14	140 HF	
	150 Joyride	01 - 06	178 CT	154 CT
	150 Super Duke	96 - 01	140 CT	2012
	150 Symphony S	11 - 15	140 CT	202 CT
	150 Symphony SR	11 - 15	140 CT	202 CT
H01	150	95 - 00	708 HF	
RS	150	05 - 06	178 CT	119 CT
VS	150	07 - 15	792 HF	
MF	180	03 - 03	551 HF	
	200 Fiddle II	11 - 13	140 CT	
	200 Fiddle III	16 - 19	140 CT	202 CT
	200 Joyride	01 - 08	178 CT	154 CT
	200 Joyride Evo	09 - 15	140 CT	
	200 Joyride S	16 - 17	178 CT	201 CT
	200 Quadlander	12 - 13	810 SI*	847 SI
	200 Trackrunner	05 - 08	810 SI*	847 SI
HD	200	04 - 06	154 CT	
HD	200 Evo	07 - 13	140 CT	201 CT
HD2	200 Evo	14 - 14	140 CT	201 CT
	250 GTS	07 - 11	146 MS	201 MS
	250 Joymax	07 - 10	171 MS	201 MS
	250 Joymax Sport	16 - 17	146 MS	201 MS
	250 Quadlander	06 - 07	810 SI*	847 SI
	250 Voyager	05 - 05	171 MS	
RV	250 Efi	10 - 10	171 MS	201 MS
SN	250 Ni Wolf	14 - 15	893 HF	810 HF
SN	250 T2 Wolf	12 - 15	893 HF	
	300 City Max	06 - 07	810 SI*	847 SI
	300 Citycom	09 - 15	140 CT	140 CT
	300 Citycom S	15 - 17	140 CT	140 CT
	300 Cruisym	17 - 17	215 MS	201 MS
	300 Joymax Evo	10 - 12	171 MS	201 MS
	300 Joymax Sport	16 - 17	171 MS	201 MS
	300 Joyride	22 - 22	178 CT	
	300 Joyride Evo i	10 - 10	146 MS	201 MS
	300 Quadlander	06 - 13	810 SI*	810 SI
	300 Wolf Cafe Racer	15 - 15	893 HF	810 HF
	300 Wolf Classic	15 - 15	893 HF	810 HF
GTS	300	09 - 13	171 MS	201 MS

\* = 2 sets required / 2 jeux pour l'Avant.

Full compound selection, see under "Brake pad 1:1 Drawings" / Sélection complète de composés, voir "1:1 Schémas Plaquettes de frein".

Applications  
Motorcycles, Off Road, ATV/UTV, Scooters

**RECOMMENDED**1xx - 2xx = Scooter Pads  
5xx - 9xx = Street, Off Road & Racing Pads  
2xxx = Brake Shoes

<b>SYM</b>					
GTS	300 Evo i	11 - 15	146 MS	201 MS	
SB	300 Cafe Racer	16 - 17	893 HF	810 HF	
	400 i Maxsym	11 - 11	214 MS*	218 MS	
	400 i Maxsym	12 - 17	215 MS*	218 MS	
	465 Maxsym TL	20 - 20	215 MS*	218 MS	
TL	500 GT	07 - 04	146 MS	154 MS	
	508 Maxsym TCS	22 - 22	215 MS*	218 MS	
	600 i Maxsym	14 - 19	215 MS*	218 MS	
	600 i Maxsym Sport	18 - 19	215 MS*	218 MS	
	600 Quad Raider	08 - 15	810 SI*	810 SI	
<b>TGB</b>					
	50 101R	05 - 09	101 HF		
	50 101S	99 - 02	101 HF		
	50 202T	99 - 02	101 HF	2188	
	50 203	05 - 08	163 HF		
	50 303R	99 - 14	101 HF		
	50 309 Racing	05 - 05	101 HF		
	50 507	05 - 05	101 HF		
	50 Akros	99 - 04	101 HF		
	50 Akros tec 5	99 - 04	163 HF		
	50 Apollo	99 - 03	163 HF		
	50 Buffalo	03 - 03		688 HF	
	50 Bull&t RS/RR	11 - 17	203 HF	101 HF	
	50 Bullet	09 - 09	101 HF	101 HF	
	50 Bullet	10 - 12	203 HF		
	50 Bunny	97 - 00	101 HF		
	50 Corona	03 - 05	132 HF		
	50 Double X	05 - 05	101 HF		
	50 Ergon	96 - 00	101 HF		
	50 Fire, Sky	03 - 05	163 HF		
	50 Hawk	09 - 14	101 HF		
	50 Hiw's	99 - 99	101 HF		
	50 Hook	10 - 12	101 HF		
	50 J409	00 - 03	101 HF		
	50 Tapo RS	11 - 12	101 HF		
	50 Trigger	99 - 03	101 HF		
GT	50 Veloce	09 - 12	141 HF		
R	50 X	06 - 14	132 HF	101 HF	
	90 101S	99 - 02	101 HF		
	90 202T	99 - 02	101 HF		
	90 Akros	99 - 99	101 HF		
	90 Apollo	99 - 02	163 HF		
	90 Ergon	99 - 02	101 HF		
	90 Hiw's	99 - 99	101 HF		
	90 Trigger	99 - 02	101 HF		
	125 101S	99 - 03	101 CT		
	125 202T	99 - 99	101 CT		
	125 303R	99 - 08	101 CT		
	125 309 RS	00 - 00	101 HF		
	125 Bull&t RS/RR	11 - 14	203 HF	101 HF	
	125 Hook	10 - 10	101 HF		
	125 X-Large	11 - 11	210 CT	201 CT	
	125 X-Motion	08 - 12	210 CT	201 CT	
	250 Dynasty	06 - 06	163 CT	111 CT	
	250 X-Motion	08 - 09	210 MS	201 CT	
	300 X-Motion	10 - 12	210 MS	201 CT	
<b>TM</b>					
	80 Cross	96 - 00	671 RSI	675 RSI	
	80 Junior	96 - 00	544 RSI	592 RSI	
MX	85	01 - 12	671 RSI	604 RSI	
MX	85	13 - 20	777 RSI	777 RSI	
SM	85	18 - 19	777 RSI	777 RSI	
EN	125 Enduro	01 - 04	671 SI	604 SI	
EN	125 Enduro	05 - 17	671 SI	790 SI	
MX	125	96 - 00	671 RSI	675 RSI	
MX	125	01 - 04	671 RSI	604 RSI	

**RECOMMENDED**1xx - 2xx = Scooter Pads  
5xx - 9xx = Street, Off Road & Racing Pads  
2xxx = Brake Shoes

<b>TM</b>					
MX	125	05 - 20	671 RSI	790 RSI	
SMR	125	05 - 05	566 RSI	604 RSI	
	250 E	95 - 00	671 RSI	675 RSI	
EN	250 Enduro	01 - 04	671 SI	604 SI	
EN	250 Enduro	05 - 15	671 SI	790 SI	
EN	250 F Enduro	00 - 00	671 SI	675 SI	
EN	250 F Enduro	01 - 04	671 SI	604 SI	
EN	250 F Enduro	05 - 17	671 SI	790 SI	
MX	250	01 - 04	671 RSI	604 RSI	
MX	250	05 - 20	671 RSI	790 RSI	
MX	250 F	01 - 04	671 RSI	604 RSI	
MX	250 F	05 - 20	671 RSI	790 RSI	
EN	300 Enduro	01 - 04	671 SI	604 SI	
EN	300 Enduro	05 - 05	671 SI	790 SI	
FT	300	17 - 19	671 RSI	790 RSI	
MX	300	98 - 00	671 RSI	675 RSI	
MX	300	01 - 04	671 RSI	604 RSI	
MX	300	05 - 20	671 RSI	790 RSI	
	320	96 - 97	671 RSI	675 RSI	
	400 F	00 - 00	671 RSI	675 RSI	
	400 F	01 - 01	671 RSI	604 RSI	
	400 F Enduro	01 - 01	671 SI	604 SI	
SMF	400 F	02 - 02	566 RSI	604 RSI	
SMR	400 F	03 - 03	566 RSI	604 RSI	
EN	450 F Enduro	02 - 04	671 SI	604 SI	
EN	450 F Enduro	05 - 17	671 SI	790 SI	
FT	450 Fi	17 - 19	671 RSI	790 RSI	
MX	450 F	02 - 04	671 RSI	604 RSI	
MX	450 F	05 - 20	671 RSI	790 RSI	
SMR	450 F	04 - 04	566 RSI	604 RSI	
SMX	450 F	03 - 03	566 RSI	604 RSI	
SMX	450 F	04 - 04	762 RST	604 RSI	
EN	530 F Enduro	01 - 04	671 SI	604 SI	
EN	530 F Enduro	05 - 05	671 SI	790 SI	
FT	530 Fi	17 - 19	671 RSI	790 RSI	
MX	530 F	01 - 04	671 RSI	604 RSI	
MX	530 F	05 - 20	671 RSI	790 RSI	
SMR	530 F	03 - 03	566 RSI	604 RSI	
SMX	600 F	03 - 03	566 RSI	604 RSI	
SMX	660 F	04 - 04	762 RST	604 RSI	
<b>TOMOS</b>					
	50 Hip Hop	06 - 08	105 HF		
	50 Racing	06 - 08	105 HF		
	50 Revival	02 - 04	123 HF		
	50 Street Soul	06 - 08	105 HF		
	50 Streetmate	03 - 05	123 HF		
	50 Youngst'r	06 - 08	105 HF		
BT	50 S	89 - 89	595 HF		
MC	50 Senior Pro	04 - 06	667 HF	667 HF	
N	50 AT, BT	91 - 95	595 HF		
SE	50	05 - 06	148 HF	105 HF	
CTX	80	89 - 89	595 HF		
MC	125 T	06 - 08	817 HF	559 HF	
SE	125	05 - 08	817 HF	559 HF	
SM	125 F	06 - 08	821 HS	559 HF	
<b>TRIUMPH</b>					
	600 Daytona	03 - 04	624 HS*	614 LS	
	600 Speed Four	03 - 06	624 HS*	614 LS	
TT	600	00 - 03	624 HS*	614 LS	
	650 Daytona	05 - 06	624 HS*	614 LS	
	660 Street Triple S	17 - 20	627 HS*	675 LS	
	660 Tiger Sport	22 - 22	627 SP*		
	660 Tiger Sport	22 - 22	627 SP*	614 LS	
	660 Trident	21 - 22	627 SP*	614 LS	
	675 Daytona	06 - 08	782 HS*	614 LS	
	675 Daytona R Triple	11 - 12	901 HS*	614 LS	

\* = 2 sets required / 2 jeux pour l'Avant.



**RECOMMENDED**

1xx - 2xx = Scooter Pads  
5xx - 9xx = Street, Off Road & Racing Pads  
2xxx = Brake Shoes



TRIUMPH				
	675 Daytona R Triple	13 - 18	901 HS*	675 LS
	675 Daytona Triple	09 - 12	864 HS*	614 LS
	675 Daytona Triple	13 - 18	864 HS*	675 LS
	675 Street Triple	08 - 12	627 HS*	614 LS
	675 Street Triple	13 - 17	627 HS*	675 LS
	675 Street Triple R	09 - 12	782 HS*	614 LS
	675 Street Triple R	13 - 17	782 HS*	675 LS
	675 Street Triple RX	15 - 16	782 HS*	675 LS
	750 Bonneville	84 - 84	554 HF	
	750 Bonneville U.K.	87 - 87	506 HF*	506 HF
	750 Daytona	91 - 92	624 HS*	633 LS
	750 Trident Left	91 - 98	611 HS	611 LS
	750 Trident Right	91 - 98	638 HS	
	750 Trident T160V	75 - 77	523 HF	523 HF
T140	750 D,E,F,V Bonneville	76 - 81	523 HF	523 HF
T140	750 ES Bonneville	81 - 83	523 HF*	523 HF
TR65	750 Thunderbird	81 - 83	523 HF	
TR7T	750 Tiger Trail	81 - 83	523 HF	
TR7V	750 Tiger	73 - 81	523 HF	523 HF
TSS	750	83 - 83	523 HF*	523 HF
TSS	750 Electro Eight Valve	84 - 84	523 HF	
TSX	750	83 - 83	523 HF	523 HF
	765 Daytona Moto2	20 - 22	901 SP*	675 LS
	765 Street Triple R	17 - 20	900 HS*	675 LS
	765 Street Triple R Low	17 - 18	900 HS*	675 LS
	765 Street Triple RS	17 - 20	901 HS*	675 LS
	765 Street Triple S	17 - 20	627 HS*	675 LS
	800 America	03 - 06	627 HS	611 LS
	800 Bonneville	01 - 04	627 HS	611 LS
	800 Bonneville America	02 - 06	627 HS	611 LS
	800 Bonneville T100			
	Centennial Edition	02 - 04	627 HS	611 LS
	800 Bonneville T100			
	Paul Smith	06 - 08	627 HS	611 LS
	800 Speedmaster	03 - 04	627 HS*	611 LS
	800 Tiger	11 - 14	627 HS*	614 LS
	800 Tiger XC	11 - 17	627 HS*	614 LS
	800 Tiger XC ABS	12 - 14	627 HS*	614 LS
	800 Tiger XCA	15 - 17	627 HS*	614 LS
	800 Tiger XCA	18 - 18	671 HS*	614 LS
	800 Tiger XCR	15 - 17	627 HS*	614 LS
	800 Tiger XCX	18 - 20	671 HS*	614 LS
	800 Tiger XR	15 - 18	627 HS*	614 LS
	800 Tiger XRT	15 - 17	627 HS*	614 LS
	800 Tiger XRT	18 - 18	671 HS*	614 LS
	800 Tiger XRX	15 - 17	627 HS*	614 LS
	800 Tiger XRX	18 - 18	671 HS*	614 LS
	800 Tiger XRX Low	18 - 20	671 HS*	614 LS
	850 Tiger Sport	21 - 21	901 SP*	675 LS
	900 Adventurer	96 - 02	627 HS	630 LS
	900 America	07 - 16	627 HS	611 LS
	900 Bonneville	05 - 08	627 HS	638 LS
	900 Bonneville	09 - 11	627 HS	611 LS
	900 Bonneville Newchurch	15 - 15	627 HS	611 LS
	900 Bonneville SE	09 - 13	627 HS	611 LS
	900 Bonneville Spirit	15 - 15	627 HS	611 LS
	900 Bonneville Street Cup	17 - 18	627 HS	611 LS
	900 Bonneville T100	05 - 20	627 HS	611 LS
	900 Bonneville T100 Black	16 - 20	627 HS	611 LS
	900 Bonneville T214	15 - 15	627 HS	611 LS
	900 Daytona	91 - 93	624 HS*	633 LS
	900 Daytona	94 - 98	624 HS*	638 LS
	900 Daytona Super III	94 - 98	683 HS*	633 LS
	900 Daytona, Sprint Left	93 - 93	611 HS	611 LS
	900 Daytona, Sprint Right	93 - 93	638 HS	
	900 Legend TT	99 - 01	627 HS	630 LS
	900 Scrambler	06 - 16	627 HS	611 LS
	900 Speed Triple	94 - 96	624 HS*	638 LS



**RECOMMENDED**

1xx - 2xx = Scooter Pads  
5xx - 9xx = Street, Off Road & Racing Pads  
2xxx = Brake Shoes



TRIUMPH				
	900 Speedmaster	05 - 15	627 HS*	611 LS
	900 Sprint	94 - 98	624 HS*	638 LS
	900 Street Cup	17 - 20	627 HS	611 LS
	900 Street Scrambler	17 - 18	627 HS	611 LS
	900 Street Scrambler	19 - 20	762 HS	611 LS
	900 Street Twin	16 - 18	627 HS	611 LS
	900 Street Twin	19 - 20	762 HS	611 LS
	900 T100 Bud Ekins	20 - 20	627 HS	611 LS
	900 Thruxton	04 - 05	627 HS	611 LS
	900 Thruxton Ace	15 - 15	627 HS	611 LS
	900 Thunderbird	96 - 05	627 HS	630 LS
	900 Thunderbird Sport	03 - 04	627 HS*	630 LS
	900 Tiger Left	93 - 98	611 HS	611 LS
	900 Tiger Right	93 - 98	638 HS	
	900 Tiger	99 - 00	627 HS*	630 LS
	900 Tiger	20 - 21	901 SP*	675 LS
	900 Tiger GT	20 - 21	901 SP*	675 LS
	900 Tiger Rally	20 - 21	901 SP*	675 LS
	900 Trident Left	91 - 98	611 HS	611 LS
	900 Trident Right	91 - 98	638 HS	
	900 Trophy Left	91 - 95	611 HS	611 LS
	900 Trophy Right	91 - 95	638 HS	
	900 Trophy	96 - 03	624 HS*	633 LS
T509	900 Speed Triple	97 - 01	624 HS*	611 LS
T595	950 Daytona	96 - 98	624 HS*	611 LS
	955 Daytona Centennial	02 - 04	624 HS*	611 LS
	955 Daytona from			
	VIN 132513	99 - 01	624 HS*	614 LS
	955 Daytona to VIN 132512	99 - 06	624 HS*	611 LS
	955 Speed Triple	99 - 06	624 HS*	611 LS
	955 Sprint RS	00 - 05	624 HS*	611 LS
	955 Sprint ST	99 - 04	624 HS*	611 LS
	955 Tiger	01 - 03	627 HS*	627 LS
	955 Tiger	04 - 06	627 HS*	638 LS
	1000 Daytona	92 - 92	624 HS*	633 LS
	1000 Trophy Left	91 - 95	611 HS	611 LS
	1000 Trophy Right	91 - 95	638 HS	
	1050 Speed 94	15 - 16	762 HS*	611 LS
	1050 Speed 94R	15 - 16	901 HS*	611 LS
	1050 Speed Triple	05 - 07	782 HS*	611 LS
	1050 Speed Triple	08 - 15	762 HS*	611 LS
	1050 Speed Triple	16 - 17	901 HS*	611 LS
	1050 Speed Triple R	12 - 18	901 HS*	611 LS
	1050 Speed Triple RS	16 - 20	901 HS*	611 LS
	1050 Speed Triple S	16 - 20	901 HS*	611 LS
	1050 Sprint GT ABS	10 - 15	624 HS*	611 LS
	1050 Sprint GT SE ABS	10 - 15	624 HS*	611 LS
	1050 Sprint ST	05 - 11	624 HS*	611 LS
	1050 Tiger	07 - 13	782 HS*	638 LS
	1050 Tiger SE	09 - 13	782 HS*	638 LS
	1050 Tiger Sport	15 - 19	782 HS*	611 LS
	1200 Bonneville Bobber	17 - 20	627 HS	614 LS
	1200 Bonneville Bobber Black	18 - 19	671 HS*	614 LS
	1200 Bonneville T120	16 - 20	627 HS	611 LS
	1200 Bonneville T120 Ace	19 - 20	627 HS	611 LS
	1200 Bonneville T120 Black	16 - 20	627 HS	611 LS
	1200 Bonneville T120			
	Diamond Ed.	19 - 20	627 HS	611 LS
	1200 Daytona	91 - 97	624 HS*	633 LS
	1200 Scrambler XC	19 - 20	901 HS*	674 LS
	1200 Scrambler XE	19 - 20	901 HS*	674 LS
	1200 Speed Triple RR	22 - 22	901 SP*	730 LS
	1200 Speed Triple RS	21 - 22	901 SP*	730 LS
	1200 Speed Twin	20 - 20	762 SP*	611 LS
	1200 Speedmaster	18 - 19	671 HS*	614 LS
	1200 T120 Bud Ekins	20 - 20	627 HS	611 LS
	1200 Thruxton	16 - 19	627 HS*	611 LS
	1200 Thruxton R	16 - 19	901 HS*	611 LS

\* = 2 sets required / 2 jeux pour l'Avant.

Full compound selection, see under "Brake pad 1:1 Drawings" / Sélection complète de composés, voir "1:1 Schémas Plaquettes de frein".

**RECOMMENDED**1xx - 2xx = Scooter Pads  
5xx - 9xx = Street, Off Road & Racing Pads  
2xxx = Brake Shoes

<b>TRIUMPH</b>				
1200 Thruxton RS	20 - 20	901 SP*	611 LS	
1200 Tiger Explorer	12 - 15	624 SP*	611 LS	
1200 Tiger Explorer	16 - 17	900 SP*	611 LS	
1200 Tiger XCA	18 - 20	900 SP*	611 LS	
1200 Tiger XCX	18 - 20	900 SP*	611 LS	
1200 Tiger XR	18 - 19	900 SP*	611 LS	
1200 Tiger XRT	18 - 20	900 SP*	611 LS	
1200 Tiger XRX	18 - 20	900 SP*	611 LS	
1200 Tiger XRX Low	18 - 20	900 SP*	611 LS	
1200 Trophy Left	91 - 95	611 HS	611 LS	
1200 Trophy Right	91 - 95	638 HS		
1200 Trophy	96 - 03	624 HS*	633 LS	
1200 Trophy SE	13 - 18	740 HS*	611 LS	
1600 Thunderbird	09 - 18	624 HS*	674 LS	
1700 Thunderbird				
Commander	14 - 18	624 HS*	674 LS	
1700 Thunderbird LT	14 - 18	624 HS*	674 LS	
1700 Thunderbird				
Nightstorm	14 - 18	624 HS*	674 LS	
1700 Thunderbird Storm	11 - 18	624 HS*	674 LS	
2300 Rocket III	04 - 13	624 HS*	674 LS	
2300 Rocket III Classic	07 - 13	624 HS*	674 LS	
2300 Rocket III Roadster	10 - 18	624 HS*	674 LS	
2300 Rocket III Touring	13 - 14	624 HS*	674 LS	
2300 Rocket X	15 - 15	624 HS*	674 LS	
2500 Rocket III GT	19 - 22	841 SP*	900 SP	
2500 Rocket III R	19 - 22	841 SP*	900 SP	

**TRS**

125 ONE	19 - 20	963 RSI	803 RSI	
125 RR ONE	19 - 20	963 RSI	803 RSI	
250 ONE	16 - 19	802 RSI	803 RSI	
250 RR ONE	19 - 20	963 RSI	803 RSI	
280 ONE	16 - 19	802 RSI	803 RSI	
280 RR ONE	19 - 20	963 RSI	803 RSI	
300 ONE	16 - 19	802 RSI	803 RSI	
300 RR ONE	19 - 20	963 RSI	803 RSI	

**VERTEMATI**

C	500 Cross	02 - 04	671 RSI	675 RSI
E	501 Enduro	02 - 04	671 SI	675 SI
S	501 Supermotard	02 - 04	671 HF	675 HF

**VERTIGO**

300 Combat Camo Works	15 - 19	939 RSI	803 RSI	
300 Combat Ice Hell	15 - 19	939 RSI	803 RSI	
300 Combat RR	15 - 19	939 RSI	803 RSI	

**VICTORY**

Empulse TT	16 - 17	706 H.HS*	730 LS	
1200 Octane	17 - 17	674 H.HS	675 H.LS	
1500 Kingpin	04 - 05	706 H.HS	674 H.LS	
1500 Touring Cruiser	03 - 06	706 H.HS*	674 H.LS	
1500 V92C Cruiser	98 - 02	706 H.HS	674 H.LS	
1500 V92C Deluxe	01 - 02	706 H.HS	674 H.LS	
1500 V92SC Sport Cruiser	00 - 02	706 H.HS*	674 H.LS	
1500 Vegas	03 - 05	706 H.HS	674 H.LS	
1500 Vegas 8-Ball	05 - 05	706 H.HS	674 H.LS	
1634 Hammer	05 - 07	706 H.HS	674 H.LS	
1634 Hammer	08 - 08	782 H.HS*	630 H.LS	
1634 Hammer S	06 - 08	706 H.HS	674 H.LS	
1634 Kingpin	06 - 07	706 H.HS	674 H.LS	
1634 Kingpin all models	08 - 12	782 H.HS	630 H.LS	
1634 Kingpin Tour	06 - 07	706 H.HS	674 H.LS	
1634 Vegas	06 - 07	706 H.HS	674 H.LS	
1634 Vegas	08 - 17	782 H.HS	630 H.LS	
1634 Vegas 8-Ball	06 - 07	706 H.HS	674 H.LS	
1634 Vegas 8-Ball	08 - 17	782 H.HS	630 H.LS	

**VICTORY**

1634 Vegas Jackpot	06 - 07	706 H.HS	674 H.LS	
1634 Vegas Jackpot	08 - 08	782 H.HS	630 H.LS	
1731 Boardwalk	13 - 15	782 H.HS	630 H.LS	
1731 Cross Country	10 - 17	782 H.HS*	630 H.LS	
1731 Cross Country 8-Ball	14 - 16	782 H.HS*	630 H.LS	
1731 Cross Country Tour	12 - 17	782 H.HS*	630 H.LS	
1731 Cross Roads	10 - 12	782 H.HS*	630 H.LS	
1731 Cross Roads 8-Ball	14 - 14	782 H.HS*	630 H.LS	
1731 Cross Roads Classic	14 - 14	782 H.HS*	630 H.LS	
1731 Gunner	15 - 17	782 H.HS	630 H.LS	
1731 Hammer	09 - 11	782 H.HS*	630 H.LS	
1731 Hammer 8-Ball	10 - 16	782 H.HS*	630 H.LS	
1731 Hammer S	09 - 17	782 H.HS*	630 H.LS	
1731 Hard-Ball	12 - 13	782 H.HS*	630 H.LS	
1731 High-Ball	12 - 17	782 H.HS	630 H.LS	
1731 Jackpot	10 - 16	782 H.HS	630 H.LS	
1731 Judge	13 - 17	782 H.HS	630 H.LS	
1731 Kingpin	10 - 12	782 H.HS	630 H.LS	
1731 Kingpin 8-Ball	10 - 11	782 H.HS	630 H.LS	
1731 Magnum	15 - 17	782 H.HS*	630 H.LS	
1731 Magnum X-1	15 - 17	782 H.HS*	630 H.LS	
1731 Vegas	10 - 17	782 H.HS	630 H.LS	
1731 Vegas 8-Ball	10 - 17	782 H.HS	630 H.LS	
1731 Vegas Jackpot	09 - 09	782 H.HS	630 H.LS	
1731 Vision all models	08 - 17	735 H.HS*	630 H.LS	

**VOR**

400 Cross	00 - 01	671 RSI	675 RSI	
400 Enduro	00 - 01	671 SI	675 SI	
EN 400	02 - 03	671 SI	675 SI	
MX 400	02 - 02	671 RSI	675 RSI	
SM 400	02 - 02	566 RSI	675 RSI	
EN 450	02 - 04	671 SI	675 SI	
MX 450	02 - 04	671 RSI	675 RSI	
SM 450	02 - 04	566 RSI	675 RSI	
500 492 Enduro	99 - 99	671 SI	675 SI	
500 492 Super Motard	00 - 01	566 HF	675 HF	
500 495 Cross	99 - 99	671 RSI	675 RSI	
EN 530	02 - 04	671 SI	675 SI	
MX 530	02 - 04	671 RSI	675 RSI	
SM 530	02 - 04	566 RSI	675 RSI	

**YAMAHA**

50 AJP Caliper				
incl. pin/spring	91 - 19	188 HF		
50 Axis Pro Foot	92 - 99	111 HF	2012	
BW 50	91 - 94	2050	2050	
BW 50	03 - 05	619 HF		
BW 50 Bump	97 - 02	123 HF	2050	
BW 50 Next Generation	96 - 07	123 HF	2050	
BW 50 Sports Spec R	02 - 06	123 HF		
BW 50 Spy	95 - 03	123 HF	2050	
CA 50 Riva Salient	83 - 86	2112	2021	
CG 50 A, B Riva Jog	90 - 91	2112	2021	
CR 50 Target	91 - 95	111 HF	2028	
CR 50 Z	91 - 95	111 HF	2050	
CV 50 A/R Jog	03 - 08	206 HF		
CV 50 Jog, Jog ZR	01 - 06	165 HF		
CW 50 TA Zuma	90 - 90	2050	2050	
CY 50 F Jog	94 - 94	2021	2028	
DT 50 R	89 - 97	107 HF	2050	
JOG 50 CY	90 - 92	2021	2050	
JOG 50 E	88 - 90	2112	2021	
JOG 50 R	02 - 07	111 HF	2050	
JOG-Z 50	90 - 91	114 HF	2021	
LB 50 Chappy	80 - 83	2032	2032	
LC 50 M, Bop, G,H Champ	80 - 81	2021	2021	
PW 50	80 - 95	2112	2112	

\* = 2 sets required / 2 jeux pour l'Avant.

Full compound selection, see under "Brake pad 1:1 Drawings" / Sélection complète de composés, voir "1:1 Schémas Plaquettes de frein".



**RECOMMENDED**

1xx - 2xx = Scooter Pads  
5xx - 9xx = Street, Off Road & Racing Pads  
2xxx = Brake Shoes



YAMAHA				
PW	50 H1	96 - 20	2112	2112
QT	50 Yamahopper	79 - 87	2112	2112
RD	50 MX	81 - 87	547 HF	2032
SG	50 Sting	84 - 91	2021	2021
SH	50 E, F Razz	93 - 95	2112	2021
SH	50 Mint	93 - 96	2112	2021
SH	50 T,EMT,U,MU,W,MW,A, MA,B,D,MD	87 - 93	2112	2021
TDR	50	90 - 92	107 HF	107 HF
TRAFIC	50 M	83 - 83	2050	2050
TT-R	50	06 - 21	2010	2010
TZM	50 R	94 - 97	134 HF	107 HF
TZR	50	90 - 92	134 HF	107 HF
TZR	50	93 - 02	134 HF	137 HF
TZR	50	03 - 04	168 HF	105 HF
YE	50 Zest (Italy)	92 - 95	114 HF	2028
YFM	50 Raptor	04 - 11	2028*	2034
YM	50 Breeze, Fizz	95 - 95	114 HF	2050
YN	50 Neo's, LC	97 - 16	123 HF	2050
YSR	50	87 - 91	575 HF	2028
YSR	50	92 - 92	575 HF	2032
YW	50 Zuma	02 - 11	111 HF	
YW	50 Zuma	12 - 17	206 HF	
YZ	50	80 - 83	2182	2182
RD	60	73 - 75	2032	2032
YF	60 S Moto 4	86 - 86		2050
YT	60 Tri Zinger	84 - 85		2050
YZ	60	85 - 85	2182	2182
YZ	65	19 - 21	589 RSI	592 RSI
BW	80	86 - 90	2182	2182
YE	80 Zest (Italy)	93 - 94	114 HF	
YFM	80	87 - 88	2050*	2034
YFM	80	92 - 94	2028*	2034
YFM	80 Badger	95 - 07	2028*	2034
YFM	80 Grizzly	05 - 08	2028*	2034
YFM	80 N, S Moto 4	85 - 86		2034
YFM	80 Raptor	02 - 08	2028*	2034
YZ	80	74 - 79	2182	2032
YZ	80	80 - 85	2182	2182
YZ	80	86 - 92	589 SI	2182
YZ	80	93 - 01	589 RSI	592 RSI
YZ	85 , LW	02 - 21	589 RSI	592 RSI
JOG	90	90 - 91	111 HF	2021
TT-R	90	00 - 10	2182	2028
YFM	90 RY Raptor	09 - 15	2028*	586 SI
	100 Aerox	00 - 06	123 HF	2034
DT	100	76 - 80	2032	2034
RS	100	75 - 80	2032	2032
RT	100 A-H	90 - 96	2028	2028
YFM	100 Champ	87 - 88	2050*	2034
YFM	100 Champ	89 - 91	2028*	2034
YZ	100	78 - 81	2032	2034
YZ	100	82 - 83	2028	2034
	110 Mio	05 - 07	165 HF	
	110 Mio Sporty	05 - 07	165 HF	
	110 Nouvo	06 - 07	165 HF	
TT-R	110	08 - 21	2182	2028
	115 D'elight	14 - 20	227 HF	
	125 Xenter	12 - 18	208 CT	2209
BWs	125	10 - 11	208 CT	2209
GPD	125 N-Max	15 - 19	226 CT	227 CT
MW	125 Tricity Left	14 - 19	222 CT	225 CT
MW	125 Tricity Right	14 - 19	223 CT	
NXC	125 Cygnus	10 - 11	207 CT	2209
NXC	125 Cygnus X	05 - 09	190 CT	2209
TT-R	125	00 - 13	2028	2028
TT-R	125 LW	00 - 20	589 SI	2028
TW	125	99 - 07	728 HF	2028



**RECOMMENDED**

1xx - 2xx = Scooter Pads  
5xx - 9xx = Street, Off Road & Racing Pads  
2xxx = Brake Shoes



YAMAHA				
TY	125	80 - 82	2032	2034
TZ	125	97 - 00	624 DC	659 RQ
WR	125	91 - 97	611 SI	632 SI
WR	125	98 - 02	694 SI	604 SI
WR	125 R, XY	09 - 16	627 HF	675 HF
XC	125 Beluga	85 - 85	2034	2034
XC	125 Beluga, Riva	87 - 92	2115	2034
XC	125 Cygnus F	00 - 08	107 CT	2034
XC	125 F	00 - 08	107 CT	2034
XC	125 TR Cygnus, R	96 - 98	107 CT	2034
XC	125 Vity	08 - 13	858 HF	
XQ	125 Maxter	01 - 05	151 CT*	157 CT
XSR	125	22 - 22	858 HF	632 HF
XT	125	82 - 86	2034	2028
YBR	125	06 - 07	575 HF	2034
YBR	125	08 - 16	858 HF	2199
YFA	125 1 D, E Breeze	92 - 93	2028*	2034
YFA	125 1 F Breeze	94 - 94	2028*	2034
YFA	125 1 G-M Breeze	95 - 07	2028*	2034
YFA	125 1 W, A, B Breeze	89 - 91	2028*	2034
YFM	125 Grizzly	04 - 13	2028*	2034
YP	125 Majesty	01 - 11	151 CT	157 CT
YP	125 RA XMAX ABS	17 - 19	229 CT	230 CT
YP	125 XMAX	06 - 09	194 CT	157 CT
YP	125 XMAX	10 - 18	181 CT	157 CT
YP	125 XMAX ABS	11 - 16	181 CT	155 CT
YP	125 XMAX Business ABS	11 - 13	181 CT	155 CT
YP	125 XMAX Sport Ed.	11 - 13	181 CT	157 CT
YT	125 Tri Moto	80 - 81		617 HF
YT	125 Tri Moto	82 - 85		576 HF
YW	125 Z	10 - 11	208 CT	2209
YW	125 Zuma	09 - 11	208 CT	
YZ	125	74 - 75	2032	2034
YZ	125	76 - 82	2033	2034
YZ	125	83 - 83	2033	2049
YZ	125	84 - 84	2036	2049
YZ	125	85 - 87	580 SI	2049
YZ	125	88 - 88	580 RSI	575 RSI
YZ	125	89 - 89	611 RSI	584 RSI
YZ	125	90 - 95	611 RSI	632 RSI
YZ	125	96 - 97	611 RSI	648 RSI
YZ	125	98 - 02	694 RSI	604 RSI
YZ	125	03 - 07	694 RSI	790 RSI
YZ	125	08 - 21	840 RSI	790 RSI
YZ	125	22 - 22	965 RSI	790 RSI
	135 Crypton X	08 - 14	858 HF	2034
	150 Xenter	12 - 18	208 CT	2209
XC	150 Fly One R	98 - 02	107 CT	2028
XQ	150 Maxter	01 - 02	151 CT*	157 CT
YP	150 Majesty	01 - 02	151 CT	157 CT
GPD	155 N-Max	15 - 19	226 CT	227 CT
XC	155 S-Max	15 - 18	181 CT	175 CT
DT	175	95 - 99	2034	2034
DT	175	00 - 00	728 HF	2034
DT	175 all models	74 - 83	2034	2034
IT	175	80 - 82	2033	2034
TY	175	77 - 80	2032	2034
YT	175 Tri Moto	82 - 83		576 HF
RT	180	90 - 93	596 HF	2034
RT	180	95 - 96	575 SI	2034
XC	180 Cygnus, Riva	83 - 85	2115	2037
SR	185 Exiter, H, J	81 - 82	2034	2028
BW	200	85 - 88	2028	2028
IT	200	84 - 84	2049	2049
IT	200	85 - 85	575 SI	2049
IT	200	86 - 86	580 HF	2049
RD	200 A, B	74 - 75	2113	2037
TT	200	86 - 89	575 HF	2028

\* = 2 sets required / 2 jeux pour l'Avant.

Full compound selection, see under "Brake pad 1:1 Drawings" / Sélection complète de composés, voir "1:1 Schémas Plaquettes de frein".

**RECOMMENDED**1xx - 2xx = Scooter Pads  
5xx - 9xx = Street, Off Road & Racing Pads  
2xxx = Brake Shoes

YAMAHA			RECOMMENDED	
TW	200	87 - 00	2034	2028
TW	200	01 - 21	728 HF	2028
WR	200	91 - 92	611 SI	632 SI
XC	200 Riva	87 - 91	2115	2034
XT	200	85 - 95	2034	2028
YFM	200 DXS-DXW Moto 4	86 - 87	2028*	576 HF
YFM	200 N Moto 4	85 - 89	2028*	576 HF
YFS	200 R Blaster	03 - 06	536 SI*	592 SI
YFS	200 U-P Blaster	88 - 02		637 SI
YTM	200 EK, EL Tri Moto	83 - 84		576 HF
YTM	200 ERN Tri Moto	85 - 85		576 HF
YTM	200 K-N Tri Moto	83 - 85		576 HF
TT	225 S,T	86 - 00	575 HF	2028
TT-R	225	01 - 04	575 SI	2028
XT	225	92 - 00	575 HF	2028
XT	225	01 - 01	728 HF	2028
XT	225 Serow	86 - 86	575 HF	2028
YFM	225 Moto 4	86 - 88	2028*	576 HF
YTM	225 DRN, DRS Tri Moto	85 - 86		576 HF
YTM	225 DXK, DXN Tri Moto	83 - 85		576 HF
TT-R	230	05 - 05	611 SI	2034
	250 Morphus	06 - 06	170 MS	169 MS
DT	250 all models	75 - 80	2035	2037
FZ	250 Phazer N, S	85 - 86	555 HF*	2034
FZ	250 R	85 - 85	570 HF	
FZ25	250	19 - 19	671 HF	632 HF
IT	250	80 - 82	2033	2037
IT	250	84 - 84	2036	2037
IT	250	85 - 86	575 SI	2037
RD	250	73 - 76	504 HF	2064
RD	250	77 - 77	504 HF	504 HF
RD	250	78 - 79	528 HF	528 HF
SR	250 SE	80 - 82	2035	2034
SRX	250 T, TC	87 - 87	570 HF	2037
TT	250	87 - 92	580 HF	2034
TT	250	93 - 03	611 SI	632 SI
TY	250	77 - 78	2032	2034
TY	250	81 - 81	2033	2037
TY	250	84 - 90	2049	2032
TY	250 R	91 - 92	559 HF	2032
TY	250 Z	93 - 96	559 HF	559 HF
TZ	250	82 - 85	504 HF	
TZ	250	90 - 05	624 DC*	659 RQ
WR	250	90 - 97	611 SI	632 SI
WR	250	98 - 02	694 SI	604 SI
WR	250 F	01 - 02	694 SI	604 SI
WR	250 F	03 - 13	694 SI	790 SI
WR	250 F Efi	15 - 17	694 SI	790 SI
WR	250 F Efi	18 - 21	840 SI	790 SI
WR	250 F Enduro GP	18 - 18	840 SI	790 SI
WR	250 R	08 - 15	694 HS	790 LS
WR	250 X	08 - 16	627 HS	790 LS
XG	250 Tricker	05 - 11	728 HF	632 HF
XS	250 C	77 - 78	507 HF	507 HF
XS	250 C	81 - 81	2113	2066
XS	250 D, E	79 - 80	507 HF	2066
XS	250 SE, SF	80 - 81	528 HF	2066
XT	250	80 - 81	2034	2034
XT	250	08 - 08	728 HF	632 HF
XV	250 Route 66	88 - 90	550 HF	2034
XV	250 Route 66	95 - 97	691 HF	2034
XV	250 S Virago	95 - 07	691 HS	2034
XV	250 Virago	88 - 88	550 HF	2034
XV	250 Virago	89 - 94	616 HF	2034
XVS	250 V-Star	08 - 12	691 HS	2034
XVS	250 V-Star	13 - 14	691 HS	
YBR	250	07 - 11	638 HF	
YFB	250 Timberwolf	92 - 94	2028*	2035



YAMAHA			RECOMMENDED	
YFB	250 Timberwolf	95 - 96	2035*	2035
YFB	250 Timberwolf 4WD	94 - 03	2035*	2035
YFM	250	89 - 91	2035*	576 SI
YFM	250 AN Bruin 2x4	05 - 07	536 SI*	
YFM	250 Bear Tracker	01 - 04	536 SI*	
YFM	250 Raptor Left	09 - 14	850 SI	592 SI
YFM	250 Raptor Right	09 - 14	849 SI	
YFM	250 Timberwolf (YFB 250 G)	95 - 95	2035*	2035
YFU1TW	250 Pro Hauler	89 - 89	2035*	2177
YFU1W	250 Pro Hauler	89 - 90	2035*	2177
YP	250 D Majesty DX	98 - 00	128 MS	155 MS
YP	250 Majesty	96 - 04	128 MS	2066
YP	250 Majesty DX/ABS	99 - 14	128 MS	155 MS
YP	250 XMAX	05 - 09	194 MS	155 MS
YP	250 XMAX	10 - 13	181 MS	155 MS
YP	250 XMAX	14 - 16	181 MS	221 MS
YTZ	250 Tri Moto	85 - 86	575 SI	575 SI
YZ	250	74 - 79	2033	2035
YZ	250	80 - 80	2033	2034
YZ	250	81 - 81	2033	2037
YZ	250	82 - 84	2036	2034
YZ	250	85 - 87	580 SI	2034
YZ	250	88 - 88	580 RSI	575 RSI
YZ	250	89 - 89	611 RSI	584 RSI
YZ	250	98 - 02	694 RSI	604 RSI
YZ	250	03 - 07	694 RSI	790 RSI
YZ	250	08 - 21	840 RSI	790 RSI
YZ	250	22 - 22	965 RSI	790 RSI
YZ	250 A	90 - 90	611 RSI	632 RSI
YZ	250 B1-J1	91 - 97	611 RSI	648 RSI
YZ	250 F	01 - 02	694 RSI	604 RSI
YZ	250 F	03 - 06	694 RSI	790 RSI
YZ	250 F	07 - 20	840 RSI	790 RSI
YZ	250 F	21 - 22	965 RSI	790 RSI
YZ	250 FX	15 - 21	840 SI	790 SI
YZ	250 WRA,WRB	90 - 91	611 RSI	632 RSI
YZ	250 X	16 - 17	840 SI	790 SI
	300 Tricity Left	20 - 20	222 CT	227 CT
	300 Tricity Right	20 - 20	223 CT	
YFM	300 Grizzly	12 - 13	544 SI*	586 SI
YFM	300 Warrior	89 - 89	536 SI	584 SI
YP	300 XMAX	17 - 20	229 CT	230 CT
YZF	321 R3	15 - 22	931 HS	932 HF
BW	350	87 - 88	2049	2032
RD	350	73 - 79	504 HF	2064
RZ	350	84 - 85	550 HF*	555 HF
RZ	350	86 - 88	570 HS*	570 LS
TT	350	86 - 87	580 SI	2034
TT	350	95 - 00	611 SI	632 SI
TY	350	86 - 86	2049	2032
XT	350	85 - 96	575 HF	2034
YFM	350 Big Bear			
	Special Edition	99 - 99	2178*	2066
YFM	350 Bruin 2x4, 4x4	04 - 07	536 SI*	
YFM	350 ERT, ERU	87 - 88	2028*	576 HF
YFM	350 ERW, ERA-G	89 - 95	2035*	576 HF
YFM	350 FWB L, LC Big Bear	99 - 99	536 SI*	2066
YFM	350 FWH, FWJ, FWK			
	Big Bear	96 - 98	2178*	2066
YFM	350 FWT, FWU Big Bear	87 - 88	2114*	576 HF
YFM	350 FWW, FWA-G Big Bear	89 - 95	2178*	576 HF
YFM	350 FXG-FXM Wolverine	95 - 11	536 SI*	592 SI
YFM	350 R Raptor	04 - 14	592 SI*	592 SI
YFM	350 UH, UJ, UK	96 - 98	2178*	2066
YFM	350 XG,XH Warrior	95 - 96	536 SI*	592 SI
YFM	350 XT, XU Warrior	87 - 88	575 SI*	592 SI
YFM	350 XW, XA-M Warrior	89 - 07	536 SI*	536 SI
YFP	350 U Terrapro	88 - 88	2035*	2177

\* = 2 sets required / 2 jeux pour l'Avant.



**RECOMMENDED**

1xx - 2xx = Scooter Pads  
5xx - 9xx = Street, Off Road & Racing Pads  
2xxx = Brake Shoes



YAMAHA				
YFZ	350 Banshee	87 - 89	575 SI*	592 SI
YFZ	350 Banshee	90 - 06	536 SI*	592 SI
XS	360 B	76 - 76	504 HF	2064
XS	360 C, D	77 - 77	507 HF	507 HF
DT	400 all models	75 - 77	2035	2037
FZR	400 A	90 - 90	613 HS	570 LS
WR	400 F	98 - 98	694 SI	648 SI
WR	400 F	99 - 00	694 SI	604 SI
XJ	400 S Seca II	93 - 93	663 HS	570 LS
XS	400	77 - 77	507 HF	507 HF
XS	400	78 - 81	2113	2066
XS	400	82 - 85	550 HF	2066
XS	400 DOHC	82 - 82	550 HF	2066
XS	400 SE Left	80 - 81	545 HF	2066
XS	400 SE Right	80 - 81	528 HF	
XS	400 SG, SH, SF	80 - 81	528 HF	2066
XS	400 Z	83 - 83	555 HF	555 HF
YFM	400 FAM Kodiak	00 - 02	536 SI*	754 SI
YFM	400 FAR Kodiak Automatic	03 - 03	536 SI*	2066
YFM	400 FWN Big Bear 4WD	00 - 11	536 SI*	754 SI
YFM	400 FWNH Big Bear-Buckmaster 4WD	00 - 11	536 SI*	754 SI
YFM	400 Kodiak	93 - 99	2178*	2066
YFM	400 N Big Bear 2WD	00 - 11	536 SI*	754 SI
YP	400 Majesty	04 - 04	170 MS	185 MS
YP	400 Majesty	05 - 13	128 MS*	185 MS
YP	400 R XMAX	13 - 16	181 MS	195 MS
YP	400 RA XMAX	14 - 16	181 MS	195 MS
YZ	400 F	77 - 79	2033	2035
YZ	400 F	98 - 98	694 RSI	648 RSI
YZ	400 F	99 - 99	694 RSI	604 RSI
IT	425	80 - 80	2033	2035
WR	426 F	01 - 02	694 SI	604 SI
YZ	426 F	00 - 02	694 RSI	604 RSI
WR	450 F	03 - 15	694 SI	790 SI
WR	450 F Efi	16 - 20	840 SI	790 SI
WR	450 F Efi	21 - 21	965 SI	790 SI
WR	450 F Enduro GP	18 - 18	840 SI	790 SI
YFM	450 FA Kodiak	03 - 07	536 SI*	754 SI
YFM	450 Wolverine	06 - 10	536 SI*	754 SI
YFZ	450 S Left	04 - 05	638 SI	592 SI
YFZ	450 S Right	04 - 05	611 SI	
YFZ	450 S Left	06 - 09	638 SI	709 SI
YFZ	450 S Right	06 - 09	611 SI	
YXR	450 Rhino Left	06 - 09	611 SI	816 SI
YXR	450 Rhino Right	06 - 09	638 SI	
YZ	450 F	03 - 07	694 RSI	790 RSI
YZ	450 F	08 - 19	840 RSI	790 RSI
YZ	450 F	20 - 22	965 RSI	790 RSI
YZ	450 FX	16 - 20	840 SI	790 SI
YZ	450 FX	21 - 22	965 SI	790 SI
IT	465	81 - 82	2036	2037
YZ	465	80 - 80	2036	2035
YZ	465	81 - 81	2036	2037
IT	490	84 - 84	2036	2037
YZ	490	81 - 82	2036	2037
YZ	490	83 - 83	2036	2034
YZ	490	84 - 84	2036	2037
YZ	490	85 - 90	580 SI	2037
IT	500 G, H.	80 - 81	2033	2035
SR	500	78 - 91	507 HF	2037
SR	500	92 - 98	2190	2037
TX	500 A, B	74 - 77	504 HF	2063
WR	500 B	91 - 91	611 SI	575 SI
WR	500 ZD,ZE	92 - 93	611 SI	632 SI
XP	500 TMAX	01 - 03	170 MS	169 MS
XP	500 TMAX	04 - 07	128 MS*	185 MS
XP	500 TMAX	08 - 11	198 MS*	185 MS



**RECOMMENDED**

1xx - 2xx = Scooter Pads  
5xx - 9xx = Street, Off Road & Racing Pads  
2xxx = Brake Shoes



YAMAHA				
XP	500 TMAX Tech Max	11 - 11	198 MS*	185 MS
XS	500	75 - 76	504 HF*	2063
XS	500	77 - 81	507 HF	507 HF
XT	500	76 - 80	2035	2037
XT	500	86 - 89	575 HF	2037
XV	500 K, Virago	83 - 83	550 HF	2063
XV	500 SE	83 - 83	550 HF	2063
XP	530 TMAX	12 - 19	198 MS*	169 MS
XP	530 TMAX DX	17 - 19	198 MS*	169 MS
XP	530 TMAX Iron Max	15 - 19	198 MS*	169 MS
XP	530 TMAX SX	17 - 19	198 MS*	169 MS
XV	535 DX Virago	98 - 03	663 HS	2065
XV	535 S Virago	96 - 03	663 HS	2065
XV	535 Virago	87 - 94	616 HF	2065
XV	535 Virago	95 - 97	663 HS	2065
XJ	550 Maxim	81 - 83	547 HF	2063
XJ	550 Seca	81 - 83	547 HF	2066
XT	550	82 - 83	2037	2037
XZ	550	82 - 82	547 HF*	2063
XZ	550	83 - 84	550 HF*	2063
XZ	550 RJ, RK	82 - 83	550 HF	2063
XZ	550 S	83 - 84	550 HF*	2063
YFM	550 FGPW Grizzly Left	09 - 16	850 SI	852 SI
YFM	550 FGPW Grizzly Right	09 - 16	849 SI	851 SI
	560 TMAX	20 - 20	198 MS*	169 MS
	560 TMAX Tech Max	20 - 20	198 MS*	169 MS
FJ	600	84 - 85	555 HF*	555 HF
FZ	600	86 - 87	555 HF*	555 HF
FZ	600 S, SC	86 - 89	555 HF*	570 HF
FZ6	600	04 - 08	691 HS*	657 LS
FZ6	600 Fazer	04 - 08	691 HS*	657 LS
FZ6	600 Fazer S2	07 - 09	634 HS*	657 LS
FZ6	600 Fazer S2 ABS	07 - 09	634 HS*	657 LS
FZ6	600 S2	07 - 09	634 HS*	657 LS
FZ6	600 S2 ABS	07 - 09	634 HS*	657 LS
FZ6R	600	09 - 14	691 HS*	614 LS
FZR	600	89 - 89	555 HF*	555 HF
FZR	600 R	90 - 91	645 HS*	555 LS
FZR	600 R	92 - 95	665 HS*	555 LS
FZS	600 Fazer	98 - 03	634 HS*	570 LS
FZS	600 S Fazer	01 - 03	634 HS*	570 LS
SRX	600	86 - 87	570 HF*	570 HF
SRX	600	88 - 89	590 HF	570 HF
SRX	600	90 - 99	613 HS	570 LS
TT	600	85 - 88	575 HF	2034
TT	600	89 - 89	596 HF	2034
TT	600	90 - 92	580 HF	2034
TT	600 K,L	83 - 84	2036	2034
XJ	600 SECA II	92 - 96	663 HS	570 LS
XT	600	83 - 86	550 HF	2037
YFM	600 4x4 Grizzly	98 - 01	592 SI*	2066
YX	600 Radian	87 - 90	555 HF*	2063
YZF	600 R	94 - 96	645 HS*	555 LS
YZF	600 R Thunder Cat	96 - 03	634 HS*	555 LS
YZF	600 R6	99 - 02	634 HS*	728 LS
YZF	600 R6	03 - 16	634 HS*	657 LS
YZF	600 R6	17 - 22	634 HS*	834 LS
YZF	600 R6 Quick change / Front wheel	17 - 22	966 DS-1*	834 LS
TX	650	72 - 73	504 HF	
XJ	650	80 - 82	507 HF*	2065
XJ	650	83 - 83	550 HF	2065
XJ	650 G, H, SH Left	80 - 83	545 HF	2065
XJ	650 G, H, SH Right	80 - 83	528 HF	
XJ	650 RJ Seca	81 - 83	507 HF*	2065
XJ	650 Turbo	81 - 82	550 HF*	2065
XS	650	75 - 77	504 HF*	2064
XS	650	75 - 85	507 HF*	507 HF

\* = 2 sets required / 2 jeux pour l'Avant.

Full compound selection, see under "Brake pad 1:1 Drawings" / Sélection complète de composés, voir "1:1 Schémas Plaquettes de frein".

**RECOMMENDED**1xx - 2xx = Scooter Pads  
5xx - 9xx = Street, Off Road & Racing Pads  
2xxx = Brake Shoes

YAMAHA					
XS	650	77 - 79	507 HF*	2064	
XS	650	80 - 82	545 HF	507 HF	
XS	650 SE	80 - 82	507 HF	507 HF	
XS	650 SJ, SK	82 - 82	507 HF*	2064	
XS	650 SK, Heritage	83 - 83	507 HF*	507 HF	
XVS	650 V-Star	09 - 14	663 HS	769 LS	
XVS	650 V-Star Classic	98 - 06	663 HS	2065	
XVS	650 V-Star Custom	98 - 06	663 HS	2065	
XVS	650 V-Star Tourer	09 - 14	663 HS	769 LS	
	660 Rhino Left	05 - 08	611 SI	816 SI	
	660 Rhino Right	05 - 08	638 SI		
XT	660 R	04 - 11	674 HS	675 LS	
XT	660 X	04 - 13	706 HS	675 LS	
XT	660 Z Tenere	08 - 15	671 HS*	675 LS	
XT	660 Z Tenere ABS	11 - 15	671 HS*	675 LS	
YFM	660 FWAP 4x4 Grizzly	02 - 08	592 SI*	799 SI	
YFM	660 RN Raptor	01 - 09	592 SI*	592 SI	
FZ	700	87 - 88	555 HF*	555 HF	
FZ-07	700	14 - 17	634 HS*	657 LS	
FZX	700 Fazer	87 - 88	555 HF	555 HF	
MT-07	700	14 - 18	634 HS*	657 LS	
MT-07	700 Moto Cage	15 - 17	634 HS*	657 LS	
MT-07	700 SP	18 - 18	634 HS*	657 LS	
MT-07	700 Tracer	16 - 20	634 HS*	657 LS	
MT-07	700 Tracer GT	19 - 19	634 HS*	657 LS	
XJ	700	86 - 89	555 HF	2065	
XJ	700 Maxim	85 - 89	555 HF	555 HF	
XSR	700	16 - 20	634 HS*	657 LS	
XSR	700 XTribute	19 - 20	634 HS*	657 LS	
XTZ	700 Tenere	19 - 21	671 HS*	675 LS	
XV	700 L, LC	84 - 87	555 HF*	2065	
XV	700 Virago	87 - 87	555 HF	2065	
YFM	700 FGPW Grizzly Left	07 - 17	850 SI	852 SI	
YFM	700 FGPW Grizzly Right	07 - 17	849 SI	851 SI	
YFM	700 R Raptor Left	06 - 08	611 SI	816 SI	
YFM	700 R Raptor Right	06 - 08	638 SI		
YFM	700 Raptor Left	09 - 12	611 SI	816 SI	
YFM	700 Raptor Right	09 - 12	638 SI		
YFM	700 Raptor Left	13 - 14	611 SI	709 SI	
YFM	700 Raptor Right	13 - 14	638 SI		
YXC	700 Viking VI Left	15 - 16	971 PSI	973 PSI	
YXC	700 Viking VI Right	15 - 16	972 PSI	974 PSI	
YXC	700 Viking VI EPS Left	15 - 21	971 PSI	973 PSI	
YXC	700 Viking VI EPS Right	15 - 21	972 PSI	974 PSI	
YXC	700 Viking VI EPS Special Edition Left	16 - 17	971 PSI	973 PSI	
YXC	700 Viking VI EPS Special Edition Right	16 - 17	972 PSI	974 PSI	
YXE	700 Wolverine Left	16 - 18	971 PSI	973 PSI	
YXE	700 Wolverine Right	16 - 18	972 PSI	974 PSI	
YXE	700 Wolverine EPS Left	17 - 17	971 PSI	973 PSI	
YXE	700 Wolverine EPS Right	17 - 17	972 PSI	974 PSI	
YXE	700 Wolverine R-Spec Left	16 - 16	971 PSI	973 PSI	
YXE	700 Wolverine R-Spec Right	16 - 16	972 PSI	974 PSI	
YXE	700 Wolverine R-Spec EPS Left	16 - 18	971 PSI	973 PSI	
YXE	700 Wolverine R-Spec EPS Right	16 - 18	972 PSI	974 PSI	
YXE	700 Wolverine R-Spec EPS SE Left	16 - 16	971 PSI	973 PSI	
YXE	700 Wolverine R-Spec EPS SE Right	16 - 16	972 PSI	974 PSI	
YXE	700 Wolverine R-Spec EPS Special Edition Left	17 - 17	971 PSI	973 PSI	
YXE	700 Wolverine R-Spec EPS Special Edition Right	17 - 17	972 PSI	974 PSI	
YXM	700 Viking Left	14 - 20	971 PSI	973 PSI	
YXM	700 Viking Right	14 - 20	972 PSI	974 PSI	

**RECOMMENDED**1xx - 2xx = Scooter Pads  
5xx - 9xx = Street, Off Road & Racing Pads  
2xxx = Brake Shoes

YAMAHA					
YXM	700 Viking EPS Left	14 - 21	971 PSI	973 PSI	
YXM	700 Viking EPS Right	14 - 21	972 PSI	974 PSI	
YXM	700 Viking EPS SE Left	14 - 17	971 PSI	973 PSI	
YXM	700 Viking EPS SE Right	14 - 17	972 PSI	974 PSI	
YXM	700 Viking EPS Special E Left	19 - 19	971 PSI	973 PSI	
YXM	700 Viking EPS Special E Right	19 - 19	972 PSI	974 PSI	
YXM	700 Viking EPS Special Edition Left	16 - 16	971 PSI	973 PSI	
YXM	700 Viking EPS Special Edition Right	16 - 16	972 PSI	974 PSI	
YXR	700 Rhino Left	08 - 14	638 SI	638 SI	
YXR	700 Rhino Right	08 - 14	611 SI	611 SI	
YZF	700 R7	22 - 22	634 SP*	657 LS	
	750 Maxim	81 - 81	547 HF	555 HF	
FZ	750	85 - 86	555 HF*	555 HF	
FZ	750 Genesis	86 - 86	555 HF*	570 HF	
FZ	750 Genesis	87 - 88	555 HF*	555 HF	
FZ	750 Genesis	89 - 92	590 HS*	555 LS	
FZR	750 R	89 - 92	624 HS*	555 LS	
FZR	750 R Genesis	87 - 88	613 HF*	555 HF	
FZX	750 Fazer	86 - 90	555 HF*	555 HF	
TX	750	73 - 74	504 HF*	2065	
TX	750 A	73 - 76	504 HF*	555 HF	
VF	750 Virago	88 - 88	555 HF	2065	
XJ	750	83 - 87	555 HF*	555 HF	
XJ	750 E	81 - 83	507 HF	2065	
XJ	750 Maxim	82 - 82	550 HF*	2065	
XJ	750 Seca	81 - 83	547 HF*	2065	
XS	750	77 - 80	507 HF*	507 HF	
XS	750 H, J, K	81 - 82	545 HF	507 HF	
XS	750 SE Left	79 - 80	545 HF	507 HF	
XS	750 SE Right	79 - 80	528 HF		
XV	750	89 - 92	555 HS	2065	
XV	750 MK	83 - 83	528 HF	2063	
XV	750 SE	81 - 83	545 HF	2063	
XV	750 Virago	93 - 97	555 HS*	2065	
XV	750 Virago	94 - 97	663 HS*	2065	
YZF	750 R, SP	93 - 97	683 HS*	555 LS	
YZF	750 R7 OW02	99 - 02	634 HS*	733 LS	
YZF	750 R7 OW02 Race kit	99 - 01	729 HS*		
	800 Fazer 8	10 - 15	634 HS*	657 LS	
FZ8	800	10 - 14	634 HS*	657 LS	
FJ-09	850	15 - 17	634 HS*	657 LS	
FZ-09	850	14 - 17	634 HS*	657 LS	
MT-09	850	18 - 18	634 HS*	657 LS	
MXT	850 Niken	18 - 22	634 HS*	991 LS	
MXT	850 Niken GT	19 - 22	634 HS*	991 LS	
TDM	850	91 - 95	590 HS*	555 LS	
TDM	850	96 - 01	645 HS*	555 LS	
XS	850	80 - 80	507 HF*	507 HF	
XS	850 Left	81 - 81	545 HF	507 HF	
XS	850 Right	81 - 81	528 HF		
YXE	850 Wolverine X2 Left	19 - 19	971 PSI	973 PSI	
YXE	850 Wolverine X2 Right	19 - 19	972 PSI	974 PSI	
YXE	850 Wolverine X2 EPS Left	20 - 20	971 PSI	973 PSI	
YXE	850 Wolverine X2 EPS Right	20 - 20	972 PSI	974 PSI	
YXE	850 Wolverine X2 R-Spec Left	19 - 20	971 PSI	973 PSI	
YXE	850 Wolverine X2 R-Spec Right	19 - 20	972 PSI	974 PSI	
YXE	850 Wolverine X2 XTR Left	20 - 20	971 PSI	973 PSI	
YXE	850 Wolverine X2 XTR Right	20 - 20	972 PSI	974 PSI	
YXF	850 Wolverine X4 Left	18 - 20	971 PSI	973 PSI	
YXF	850 Wolverine X4 Right	18 - 20	972 PSI	974 PSI	
YXF	850 Wolverine X4 SE Left	19 - 19	971 PSI	973 PSI	
YXF	850 Wolverine X4 SE Right	19 - 19	972 PSI	974 PSI	

\* = 2 sets required / 2 jeux pour l'Avant.





**RECOMMENDED**  
 1xx - 2xx = Scooter Pads  
 5xx - 9xx = Street, Off Road & Racing Pads  
 2xxx = Brake Shoes



**RECOMMENDED**  
 1xx - 2xx = Scooter Pads  
 5xx - 9xx = Street, Off Road & Racing Pads  
 2xxx = Brake Shoes



YAMAHA					
YXF	850 Wolverine X4				
	Special Left	19 - 19	971 PSI	973 PSI	
YXF	850 Wolverine X4				
	Special Right	19 - 19	972 PSI	974 PSI	
YXF	850 Wolverine X4				
	Special Edition Left	18 - 18	971 PSI	973 PSI	
YXF	850 Wolverine X4				
	Special Edition Right	18 - 18	972 PSI	974 PSI	
YXF	850 Wolverine X4 XTR Left	20 - 20	971 PSI	973 PSI	
YXF	850 Wolverine X4 XTR Right	20 - 20	972 PSI	974 PSI	
MT-09	900	14 - 20	634 HS*	657 LS	
MT-09	900 SP	18 - 20	634 HS*	657 LS	
MT-09	900 Sport Tracker	15 - 16	634 HS*	657 LS	
MT-09	900 Street Rally	14 - 16	634 HS*	657 LS	
MT-09	900 Tracer	15 - 20	634 HS*	657 LS	
MT-09	900 Tracer GT	18 - 20	634 HS*	657 LS	
XJ	900	83 - 93	555 HF*	555 HF	
XSR	900	16 - 22	634 HS*	657 LS	
XSR	900 Abarth	17 - 18	634 HS*	657 LS	
XV	920	81 - 82	507 HF		
XV	920 J	82 - 82	547 HF	2065	
XV	920 K, MK, Virago	83 - 83	545 HF	550 HF	
SCR	950 Scrambler	17 - 19	663 HS	769 LS	
XV	950 Bolt	14 - 18	663 HS	769 LS	
XV	950 Bolt C-Spec	15 - 18	663 HS	769 LS	
XV	950 Bolt Racer	17 - 18	663 HS	769 LS	
XV	950 Bolt R-Spec	14 - 21	663 HS	769 LS	
XVS	950 A Midnight Star	09 - 13	663 HS	769 LS	
	1000 Wolverine RMAX 4	21 - 21	979 PSI*	980 PSI*	
	1000 Wolverine RMAX 4 LE	21 - 21	979 PSI*	980 PSI*	
	1000 Wolverine RMAX 4 SE	21 - 21	979 PSI*	980 PSI*	
FZ1	1000 Fazer	06 - 16	634 HS*	657 LS	
FZ-10	1000	16 - 17	634 HS*	657 LS	
FZR	1000	94 - 95	683 HS*	555 LS	
FZR	1000 EX UP	90 - 91	645 HS*	555 LS	
FZR	1000 EX UP	92 - 93	665 HS*	555 LS	
FZR	1000 Genesis	87 - 89	613 HF*	555 HF	
FZS	1000 Fazer	01 - 05	634 HS*	770 LS	
GTS	1000	93 - 99	682 HF	555 HF	
MT-10	1000	16 - 22	634 HS*	657 LS	
MT-10	1000 SP	17 - 19	634 HS*	657 LS	
XV	1000 L, C	84 - 85	555 HF*	555 HF	
YXE	1000	21 - 21	979 PSI*	980 PSI*	
YXZ	1000 EPS	16 - 20	979 PSI*	980 PSI*	
YXZ	1000 EPS SE	17 - 19	979 PSI*	980 PSI*	
YXZ	1000 EPS Special	20 - 20	979 PSI*	980 PSI*	
YXZ	1000 EPS Special Edition	16 - 17	979 PSI*	980 PSI*	
YXZ	1000 EPS SS	17 - 20	979 PSI*	980 PSI*	
YXZ	1000 SS Special	20 - 20	979 PSI*	980 PSI*	
YXZ	1000 SS XTR	20 - 20	979 PSI*	980 PSI*	
YZF	1000 R Thunder Ace	96 - 99	634 HS*	555 LS	
YZF	1000 R1	98 - 01	634 HS*	733 LS	
YZF	1000 R1	02 - 03	634 HS*	728 LS	
YZF	1000 R1	04 - 06	634 HS*	657 LS	
YZF	1000 R1	15 - 22	634 SP*	834 LS	
YZF	1000 R1 (4-pad)	07 - 14	839 SP*	657 LS	
YZF	1000 R1 (4-pad) ABS	12 - 14	839 SP*	657 LS	
YZF	1000 R1 LE	06 - 06	634 HS*	657 LS	
YZF	1000 R1M	15 - 22	634 SP*	834 LS	
YZF	1000 R1S	16 - 16	634 SP*	834 LS	
	1100 SE, Maxim	81 - 81	547 HF		
BT	1100 Bulldog	02 - 06	634 HS*	555 LS	
FJ	1100	83 - 85	555 HF*	555 HF	
XJ	1100	81 - 81	547 HF*	528 HF	
XS	1100 E,F,G,H	78 - 81	507 HF*	507 HF	
XS	1100 LH Midnight	81 - 81	547 HF*	528 HF	
XS	1100 SF, SG, SH, LG Left	79 - 81	545 HF	507 HF	
XS	1100 SF, SG, SH, LG Right	79 - 81	528 HF		

YAMAHA					
XV	1100	94 - 97	555 HS*	2065	
XV	1100 Virago	86 - 93	555 HF*	2065	
XV	1100 Virago	94 - 98	663 HS*	2065	
XV	1100 Virago	99 - 99	691 HS*	555 LS	
XVS	1100 V-Star	99 - 06	691 HS*	555 LS	
XVS	1100 V-Star Classic	00 - 06	691 HS*	555 LS	
FJ	1200	86 - 87	555 HF*	555 HF	
FJ	1200	88 - 90	613 HF*	555 HF	
FJ	1200 ABS	91 - 93	613 HS*	555 LS	
V-MAX	1200	85 - 89	555 HF*	555 HF	
V-MAX	1200	90 - 92	555 HS*	555 LS	
V-MAX	1200	93 - 03	645 HS*	555 LS	
XT	1200 Z Super Tenere	14 - 19	634 SP*	769 LS	
XT	1200 ZE Super Tenere	14 - 19	634 SP*	769 LS	
	Raid Ed.	18 - 19	634 SP*	769 LS	
XTZ	1200 Super Tenere	10 - 13	634 SP*	769 LS	
XV	1200	84 - 87	555 HF*	555 HF	
XV	1200 Venture Royale	85 - 85	555 HF*	555 HF	
XV	1200 Z12T	84 - 87	555 HF*	555 HF	
XVT	1200 T, Vent. Royale	84 - 85	555 HF*	555 HF	
FJR	1300	01 - 03	634 HS*	769 LS	
FJR	1300 A	13 - 20	740 HS*	769 LS	
FJR	1300 ABS	03 - 05	634 HS*	769 LS	
FJR	1300 ABS	06 - 12	740 HS*	769 LS	
FJR	1300 AE	16 - 19	740 HS*	769 LS	
FJR	1300 AS	13 - 19	740 HS*	769 LS	
XJR	1300 Racer	15 - 19	634 HS*	770 LS	
XJR	1300 SP	01 - 01	634 HS*	555 LS	
XVS	1300 A Midnight Star	07 - 11	691 HS*	769 LS	
XVS	1300 Custom	14 - 16	691 HS	769 LS	
XVS	1300 Stryker	11 - 14	663 HS	769 LS	
XVS	1300 Stryker Bullet Cowl	15 - 15	663 HS	769 LS	
XVS	1300 V-Star	07 - 14	691 HS*	769 LS	
XVS	1300 V-Star Deluxe	07 - 14	691 HS*	769 LS	
XVS	1300 V-Star Tourer	07 - 14	691 HS*	769 LS	
XVZ	1300 A Royal Star	96 - 07	613 HS*	590 LS	
XVZ	1300 AT Royal Star				
	Tour Classic	97 - 07	613 HS*	590 LS	
XVZ	1300 Royal Star Boulevard	99 - 01	613 HS*	590 LS	
XVZ	1300 Royal Star Venture S	08 - 13	663 HS*	590 LS	
XVZ	1300 TF Royal Star Venture	99 - 01	663 HS*	590 LS	
XVZ	1300 Venture Royale	86 - 89	613 HF*	590 HF	
XVZ	1300 Venture Royale	90 - 95	613 HS*	590 LS	
XV	1600 Midnight Star	99 - 07	663 HS*	590 LS	
XV	1600 Road Star	99 - 07	663 HS*	590 LS	
XV	1600 Silverado	99 - 07	663 HS*	590 LS	
VMX	1700 V-Max	09 - 18	839 HS*	769 LS	
XV	1700 PC Road Star Warrior	03 - 07	634 HS*	769 LS	
XV	1700 Road Star S	08 - 14	634 HS*	590 LS	
XV	1700 Road Star Silverado S	11 - 14	634 HS*	590 LS	
XV	1700 Road Star Warrior	02 - 02	634 HS*	590 LS	
XV	1900 Raider	08 - 14	634 HS*	769 LS	
XV	1900 Raider Bullet Cowl	15 - 15	634 HS*	769 LS	
XV	1900 Raider S	08 - 14	634 HS*	769 LS	
XV	1900 Raider SCL	12 - 14	634 HS*	769 LS	
XV	1900 Roadliner	06 - 14	634 HS*	769 LS	
XV	1900 Roadliner S	06 - 14	634 HS*	769 LS	
XV	1900 Stratoliner	06 - 09	634 HS*	769 LS	
XV	1900 Stratoliner Deluxe	11 - 14	634 HS*	769 LS	
XV	1900 Stratoliner S	06 - 14	634 HS*	769 LS	
<b>ZERO</b>					
DS	ZF11.4	13 - 13	694 HS	790 LS	
DS	ZF11.4	14 - 14	694 HS	675 LS	
DS	ZF12.5	15 - 15	674 HS	675 LS	
DS	ZF13.0	16 - 17	674 HS	675 LS	
DS	ZF6.0	10 - 12	708 HF	544 HF	

\* = 2 sets required / 2 jeux pour l'Avant.

Full compound selection, see under "Brake pad 1:1 Drawings" / Sélection complète de composés, voir "1:1 Schémas Plaquettes de frein".

**RECOMMENDED**

1xx - 2xx = Scooter Pads  
5xx - 9xx = Street, Off Road & Racing Pads  
2xxx = Brake Shoes



**RECOMMENDED**

1xx - 2xx = Scooter Pads  
5xx - 9xx = Street, Off Road & Racing Pads  
2xxx = Brake Shoes



ZERO				
DS	ZF8.5	13 - 13	694 HS	790 LS
DS	ZF8.5	14 - 14	694 HS	675 LS
DS	ZF9.0	10 - 12	708 HF	544 HF
DS	ZF9.4	15 - 15	674 HS	675 LS
DS	ZF9.8	16 - 17	674 HS	675 LS
DSR	ZF13.0	16 - 17	674 HS	675 LS
DSRBF	ZF14.4	19 - 21	706 HS	675 LS
FX	ZF2.8	13 - 13	694 HS	790 LS
FX	ZF2.8	14 - 14	694 HS	675 LS
FX	ZF2.8	15 - 15	671 HS	675 LS
FX	ZF3.3	16 - 17	674 HS	675 LS
FX	ZF5.7	13 - 13	694 HS	790 LS
FX	ZF5.7	14 - 14	694 HS	675 LS
FX	ZF5.7	15 - 15	671 HS	675 LS
FX	ZF6.5	16 - 17	674 HS	675 LS
FXS	ZF3.3	16 - 17	674 HS	675 LS
FXS	ZF6.5	16 - 17	674 HS	675 LS
MX		10 - 12	708 HF	544 HF
MX	ZF2.8	13 - 13	694 RSI	790 RSI
MX	ZF5.7	13 - 13	694 RSI	790 RSI
S	ZF11.4	13 - 13	694 HS	790 LS
S	ZF11.4	14 - 14	694 HS	675 LS
S	ZF12.5	15 - 15	674 HS	675 LS
S	ZF13.0	16 - 17	674 HS	675 LS
S	ZF6.0	10 - 12	708 HF	544 HF
S	ZF8.5	13 - 13	694 HS	790 LS
S	ZF8.5	14 - 14	694 HS	675 LS
S	ZF9.4	15 - 15	674 HS	675 LS
S	ZF9.8	16 - 17	674 HS	675 LS
SR	ZF11.4	14 - 14	694 HS	675 LS
SR	ZF12.5	15 - 15	674 HS	675 LS
SR	ZF13.0	16 - 17	674 HS	675 LS
SR/F	ZF14.4	19 - 21	706 HS*	675 LS
SR/S	ZF14.4	19 - 21	706 HS*	675 LS
X		10 - 12	708 HF	544 HF
XU		11 - 12	708 HF	544 HF
XU	ZF2.8	13 - 13	694 HS	790 LS
XU	ZF5.7	13 - 13	694 HS	790 LS

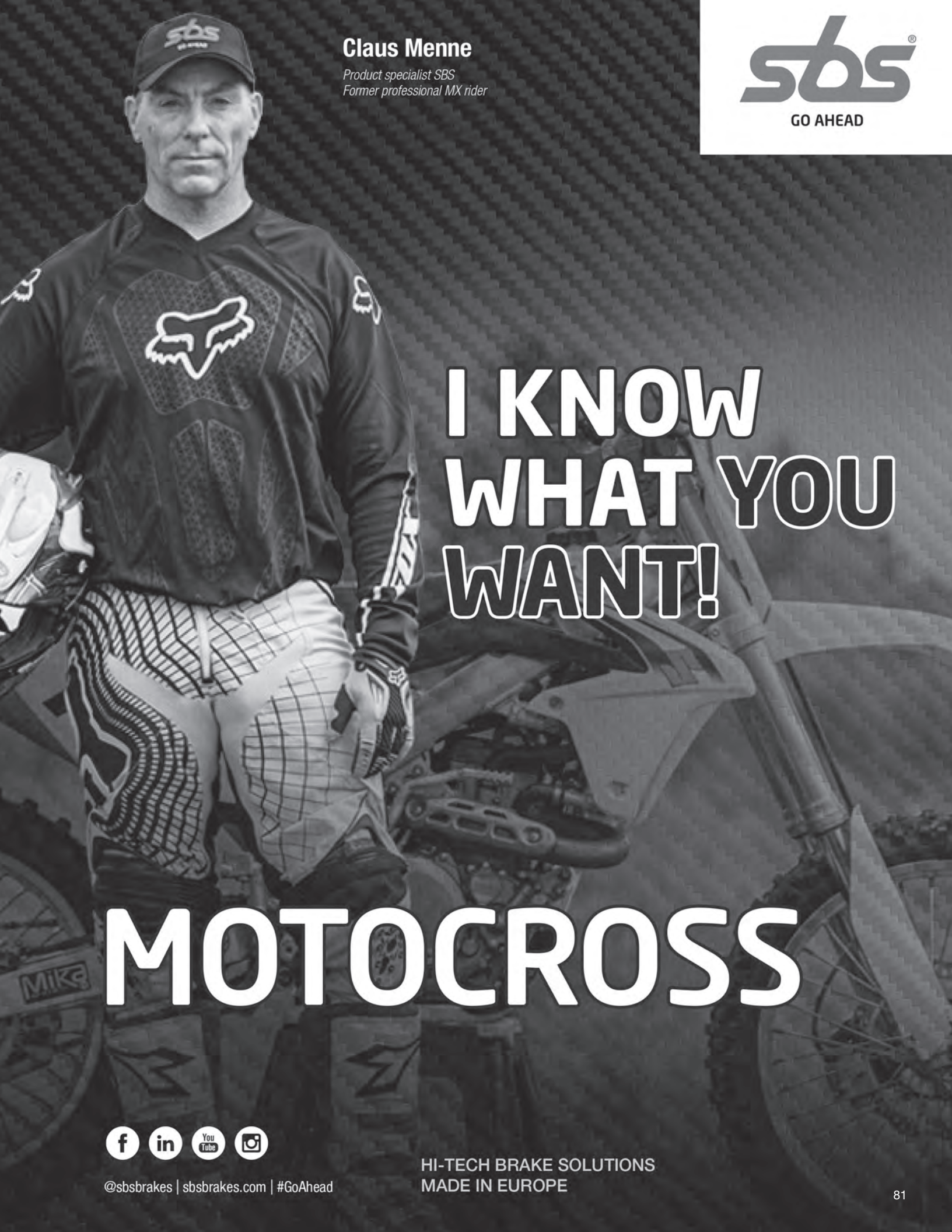

**Claus Menne**

*Product specialist SBS  
Former professional MX rider*

**sbs**<sup>®</sup>

GO AHEAD

**I KNOW  
WHAT YOU  
WANT!**

**MOTOCROSS**



@sbsbrakes | sbsbrakes.com | #GoAhead

HI-TECH BRAKE SOLUTIONS  
MADE IN EUROPE



COMPOUND CHOICE

COMPOUND CHOICE



					RSI	SI	CS		RSI	SI	CS
<b>APRILIA</b>											
MXV	450	09 - 13	694	△	△	△	790	△	△	△	
<b>BENELLI</b>											
BX	449 Cross	07 - 09	671	△	△	△	675	△	△	△	
<b>CCM</b>											
	450 MX	08 - 10	671	△	△	△	790	△	△	△	
<b>FANTIC</b>											
XX	125	20 - 21	840	△	△	△	790	△	△	△	
XX	125	22 - 22	965	△	△		790	△	△	△	
XX	250	22 - 22	965	△	△		790	△	△	△	
XXF	250	22 - 22	965	△	△		790	△	△	△	
XXF	450	22 - 22	965	△	△		790	△	△	△	
<b>GAS GAS</b>											
MC	65	21 - 22	783	△	△	△	783	△	△	△	
MC	85	21 - 22	671	△	△	△	791	△	△	△	
MC	125	03 - 13	694	△	△	△	604	△	△	△	
MC	125	21 - 22	671	△	△	△	791	△	△	△	
MC	250	97 - 99	671	△	△	△	675	△	△	△	
MC	250 F	21 - 22	671	△	△	△	791	△	△	△	
MC	350 F	22 - 22	671	△	△	△	791	△	△	△	
MC	450 F	21 - 22	671	△	△	△	791	△	△	△	
<b>HONDA</b>											
CR	80 R, RB	92 - 02	584	△	△		604	△	△	△	
CR	85 R, R Expert	03 - 12	592	△	△	△	604	△	△	△	
CR	125 R	95 - 01	694	△	△	△	604	△	△	△	
CR	125 R	02 - 07	694	△	△	△	777	△	△	△	
CR	125 RH, RJ, RK	87 - 94	603	△	△		604	△	△	△	
CRF	150 R	07 - 21	592	△	△	△	777	△	△	△	
CR	250 R	87 - 94	603	△	△		604	△	△	△	
CR	250 R	95 - 01	694	△	△	△	604	△	△	△	
CR	250 R	02 - 07	694	△	△	△	777	△	△	△	
CRF	250 R	04 - 22	694	△	△	△	777	△	△	△	
CRF	450 R	02 - 22	694	△	△	△	777	△	△	△	
CRF	450 R-S	22 - 22	694	△	△	△	777	△	△	△	
CRF	450 RWE	19 - 22	694	△	△	△	777	△	△	△	
CRF	450 RX	17 - 22	694	△	△	△	777	△	△	△	
CR	500 R	87 - 94	603	△	△		604	△	△	△	
CR	500 R	95 - 01	694	△	△	△	604	△	△	△	
<b>HUSABERG</b>											
FC	400	99 - 02	671	△	△	△	675	△	△	△	
FC	450	03 - 08	671	△	△	△	675	△	△	△	
FC	470 , e	01 - 02	671	△	△	△	675	△	△	△	
FC	501	99 - 01	671	△	△	△	675	△	△	△	
FC	550	01 - 05	671	△	△	△	675	△	△	△	
FC	600	99 - 01	671	△	△	△	675	△	△	△	
<b>HUSQVARNA</b>											
CR	65	12 - 13	783	△	△	△	872	△	△	△	
TC	65	17 - 22	783	△	△	△	783	△	△	△	
TC	85	14 - 20	885	△	△	△	872	△	△	△	
TC	85	21 - 22	671	△	△	△	791	△	△	△	
CR	125	05 - 13	671	△	△	△	791	△	△	△	
TC	125	14 - 22	671	△	△	△	791	△	△	△	
CR	250	96 - 04	671	△	△	△	675	△	△	△	
CR	250	05 - 05	671	△	△	△	791	△	△	△	
FC	250	14 - 22	671	△	△	△	791	△	△	△	
TC	250	02 - 03	671	△	△	△	675	△	△	△	
TC	250	04 - 22	671	△	△	△	791	△	△	△	
TC	300	14 - 15	671	△	△	△	791	△	△	△	
FC	350	14 - 22	671	△	△	△	791	△	△	△	
TC	449	11 - 13	671	△	△	△	791	△	△	△	
FC	450	14 - 22	671	△	△	△	791	△	△	△	
TC	450	02 - 03	671	△	△	△	675	△	△	△	

△ = Available quality / Qualité disponible.

To select compound for off-road front/rear - see page 21-23 / Pour sélectionner vos plaquettes off-road avant/arrière - voir page 21-23.



COMPOUND CHOICE

COMPOUND CHOICE



HUSQVARNA				RSI	SI	CS		RSI	SI	CS	
TC 450		04 - 10	671	△	△	△	791	△	△	△	
TC 510		02 - 03	671	△	△	△	675	△	△	△	
TC 510		04 - 10	671	△	△	△	791	△	△	△	
TC 570		01 - 13	671	△	△	△	675	△	△	△	
TC 610		96 - 13	671	△	△	△	675	△	△	△	
<b>KAWASAKI</b>											
KX 65		00 - 21	752	△	△	△	536	△	△		
KX 80		88 - 96	544	△	△	△	592	△	△	△	
KX 80		97 - 00	726	△	△	△	592	△	△	△	
KX 85		01 - 22	726	△	△	△	592	△	△	△	
KX 85 II		01 - 22	726	△	△	△	592	△	△	△	
KX 100		88 - 96	544	△	△	△	592	△	△	△	
KX 100		97 - 21	726	△	△	△	592	△	△	△	
KX 112		22 - 22	726	△	△	△	592	△	△	△	
KX 125		86 - 86	546	△	△		586	△	△		
KX 125		89 - 93	611	△	△		632	△	△		
KX 125		94 - 94	694	△	△	△	632	△	△		
KX 125		95 - 08	694	△	△	△	604	△	△	△	
KX 250		86 - 86	546	△	△		586	△	△		
KX 250		89 - 93	611	△	△		632	△	△		
KX 250		94 - 94	694	△	△	△	632	△	△		
KX 250		95 - 08	694	△	△	△	604	△	△	△	
KX 250		19 - 22	694	△	△	△	790	△	△	△	
KX 250 F		04 - 18	694	△	△	△	790	△	△	△	
KX 250 X		21 - 22	694	△	△	△	790	△	△	△	
KX 450		19 - 22	694	△	△	△	790	△	△	△	
KX 450 F		06 - 18	694	△	△	△	790	△	△	△	
KX 450 X		21 - 22	694	△	△	△	790	△	△	△	
KX 500		86 - 86	546	△	△		586	△	△		
KX 500		89 - 93	611	△	△		632	△	△		
KX 500		94 - 95	694	△	△	△	632	△	△		
KX 500		96 - 04	694	△	△	△	604	△	△	△	
<b>KTM</b>											
SX 60		99 - 99	559	△	△	△	-				
SX 65		00 - 01	559	△	△	△	574	△	△	△	
SX 65		02 - 03	783	△	△	△	574	△	△	△	
SX 65		04 - 08	783	△	△	△	794	△	△		
SX 65		09 - 22	783	△	△	△	783	△	△	△	
SX 85		04 - 10	783	△	△	△	783	△	△	△	
SX 85		11 - 11	783	△	△	△	872	△	△	△	
SX 85		12 - 20	885	△	△	△	872	△	△	△	
SX 85		21 - 22	671	△	△	△	791	△	△	△	
SX 85 (19"/16" wheels)		13 - 20	885	△	△	△	872	△	△	△	
SX 85 (19"/16" wheels)		21 - 22	671	△	△	△	791	△	△	△	
SX 125		96 - 03	671	△	△	△	675	△	△	△	
SX 125		04 - 22	671	△	△	△	791	△	△	△	
SX 144		07 - 08	671	△	△	△	791	△	△	△	
SX 150		09 - 22	671	△	△	△	791	△	△	△	
SX 200		03 - 04	671	△	△	△	791	△	△	△	
SX 250		96 - 02	671	△	△	△	675	△	△	△	
SX 250		03 - 22	671	△	△	△	791	△	△	△	
SX-F 250		06 - 22	671	△	△	△	791	△	△	△	
SX-F 350		11 - 22	671	△	△	△	791	△	△	△	
SX 360		96 - 97	671	△	△	△	675	△	△	△	
SX 380		98 - 02	671	△	△	△	675	△	△	△	
SX 400 Racing		00 - 02	671	△	△	△	675	△	△	△	
SX-F 450		03 - 22	671	△	△	△	791	△	△	△	
SX 505 Racing		07 - 09	671	△	△	△	791	△	△	△	
SX-F 520 Racing		00 - 02	671	△	△	△	675	△	△	△	
SX-F 525 Racing		03 - 03	671	△	△	△	675	△	△	△	
SX-F 525 Racing		04 - 06	671	△	△	△	791	△	△	△	
SX 620		95 - 99	671	△	△	△	675	△	△	△	
<b>LEM</b>											
RX 65		05 - 10	794	△	△		794	△	△		

Applications  
Motocross

△ = Available quality / Qualité disponible.

To select compound for off-road front/rear - see page 21-23 / Pour sélectionner vos plaquettes off-road avant/arrière - voir page 21-23.



## COMPOUND CHOICE

## COMPOUND CHOICE



POLINI					RSI	SI	CS		RSI	SI	CS
X5	65 RP	05 - 06	794	△	△			794	△	△	
<b>SHERCO</b>											
SX	250 2.5i-F	09 - 11	671	△	△	△		790	△	△	△
<b>SUZUKI</b>											
RM	65	03 - 06	752	△	△	△		536	△	△	
RM	80	96 - 01	702	△	△	△		544	△	△	△
RM	85	02 - 04	702	△	△	△		544	△	△	△
RM	85	05 - 21	726	△	△	△		820	△	△	△
RM	100	03 - 03	726	△	△	△		592	△	△	△
RM	125	88 - 88	611	△	△			584	△	△	
RM	125	89 - 90	611	△	△			632	△	△	
RM	125	91 - 95	611	△	△			648	△	△	
RM	125	96 - 09	694	△	△	△		604	△	△	△
RM	250	87 - 88	611	△	△			584	△	△	
RM	250	89 - 90	611	△	△			632	△	△	
RM	250	91 - 95	611	△	△			648	△	△	
RM	250	96 - 09	694	△	△	△		604	△	△	△
RMX	250	89 - 95	611	△	△			648	△	△	
RMX	250	96 - 98	694	△	△	△		648	△	△	
RM-Z	250	04 - 22	694	△	△	△		790	△	△	△
RM-Z	450	05 - 22	694	△	△	△		790	△	△	△
RM	500	88 - 89	611	△	△			592	△	△	△
<b>TM</b>											
	80 Cross	96 - 00	671	△	△	△		675	△	△	△
	80 Junior	96 - 00	544	△	△	△		592	△	△	△
MX	85	01 - 12	671	△	△	△		604	△	△	△
MX	85	13 - 20	777	△	△	△		777	△	△	△
MX	125	96 - 00	671	△	△	△		675	△	△	△
MX	125	01 - 04	671	△	△	△		604	△	△	△
MX	125	05 - 20	671	△	△	△		790	△	△	△
	250 E	95 - 00	671	△	△	△		675	△	△	△
MX	250	01 - 04	671	△	△	△		604	△	△	△
MX	250	05 - 20	671	△	△	△		790	△	△	△
MX	250 F	01 - 04	671	△	△	△		604	△	△	△
MX	250 F	05 - 20	671	△	△	△		790	△	△	△
MX	300	98 - 00	671	△	△	△		675	△	△	△
MX	300	01 - 04	671	△	△	△		604	△	△	△
MX	300	05 - 20	671	△	△	△		790	△	△	△
	320	96 - 97	671	△	△	△		675	△	△	△
	400 F	00 - 00	671	△	△	△		675	△	△	△
	400 F	01 - 01	671	△	△	△		604	△	△	△
MX	450 F	02 - 04	671	△	△	△		604	△	△	△
MX	450 F	05 - 20	671	△	△	△		790	△	△	△
MX	530 F	01 - 04	671	△	△	△		604	△	△	△
MX	530 F	05 - 20	671	△	△	△		790	△	△	△
<b>YAMAHA</b>											
YZ	65	19 - 21	589	△	△	△		592	△	△	△
YZ	80	93 - 01	589	△	△	△		592	△	△	△
YZ	85 , LW	02 - 21	589	△	△	△		592	△	△	△
YZ	125	88 - 88	580	△	△			575	△	△	
YZ	125	89 - 89	611	△	△			584	△	△	
YZ	125	90 - 95	611	△	△			632	△	△	
YZ	125	96 - 97	611	△	△			648	△	△	
YZ	125	98 - 02	694	△	△	△		604	△	△	△
YZ	125	03 - 07	694	△	△	△		790	△	△	△
YZ	125	08 - 21	840	△	△	△		790	△	△	△
YZ	125	22 - 22	965	△	△			790	△	△	△
YZ	250	88 - 88	580	△	△			575	△	△	
YZ	250	89 - 89	611	△	△			584	△	△	
YZ	250	98 - 02	694	△	△	△		604	△	△	△
YZ	250	03 - 07	694	△	△	△		790	△	△	△
YZ	250	08 - 21	840	△	△	△		790	△	△	△
YZ	250	22 - 22	965	△	△			790	△	△	△
YZ	250 A	90 - 90	611	△	△			632	△	△	△

△ = Available quality / Qualité disponible.



COMPOUND CHOICE

COMPOUND CHOICE



YAMAHA				COMPOUND CHOICE			COMPOUND CHOICE			
				RSI	SI	CS		RSI	SI	CS
YZ	250 B1-J1	91 - 97	611	△	△		648	△	△	
YZ	250 F	01 - 02	694	△	△	△	604	△	△	△
YZ	250 F	03 - 06	694	△	△	△	790	△	△	△
YZ	250 F	07 - 20	840	△	△	△	790	△	△	△
YZ	250 F	21 - 22	965	△	△		790	△	△	△
YZ	250 WRA,WRB	90 - 91	611	△	△		632	△	△	
YZ	400 F	98 - 98	694	△	△	△	648	△	△	
YZ	400 F	99 - 99	694	△	△	△	604	△	△	△
YZ	426 F	00 - 02	694	△	△	△	604	△	△	△
YZ	450 F	03 - 07	694	△	△	△	790	△	△	△
YZ	450 F	08 - 19	840	△	△	△	790	△	△	△
YZ	450 F	20 - 22	965	△	△		790	△	△	△

Applications Motocross

ALMOST ANY BIKE  
BRAKE PADS, CLUTCH KITS AND BRAKE ROTORS

Find the right part with  
the PRODUCT SELECTOR  
at SBSBRAKES.COM

**sbs**<sup>®</sup>  
GO AHEAD



HI-TECH BRAKE SOLUTIONS  
MADE IN EUROPE

Find the right brake pads, discs or clutches for your bike

Select the fields in any order

Brand\*  CC\*  Model\*  Year\*

SHOW MATCHES >

NEW SEARCH



@sbsbrakes | sbsbrakes.com | #GoAhead



**WE KNOW  
WHAT YOU  
WANT!**



**ATV / UTV**





### COMPOUND CHOICE

5xx - 9xx = ATV/UTV Brake Pads  
2xxx = Brake Shoes



### COMPOUND CHOICE

5xx - 9xx = ATV/UTV Brake Pads  
2xxx = Brake Shoes



				HF	ATS	SI	RSI	PSI		HF	ATS	SI	RSI	PSI
<b>ADLY</b>														
	150 ATV	05 - 07	544*	△		△	△		544	△		△	△	
	150 Interceptor	05 - 07	544*	△		△	△		544	△		△	△	
	300 ATV	05 - 11	544*	△		△	△		544	△		△	△	
	300 Cross X Over	07 - 11	810*	△		△	△							
	300 Cross X Road	07 - 11	810*	△		△	△							
ATV	300 Sport	07 - 13	810*	△		△	△		848	△		△		
	320 S	07 - 13	810*	△		△	△							
	320 U	07 - 13	810*	△		△	△							
<b>ARCTIC CAT</b>														
	50 2WD	04 - 06	2048*											
	50 DVX	06 - 08	2048*						638	△		△	△	△
	90 2WD	02 - 04	2048*											
	90 DVX	06 - 14	2048*						638	△		△	△	△
	250 2x4	05 - 06	822*		△	△	△	△	822		△	△	△	△
	250 2x4 (Man. Hand Brake)	99 - 04							827		△			
	250 2x4/4x4	99 - 04	758*		△	△	△		758		△	△	△	
	250 4x4 (Man. Hand Brake)	00 - 04							827		△			
	250 DVX	06 - 09	810*	△		△	△		775	△		△	△	
	300 2x4	10 - 13	822*		△	△	△	△	822		△	△	△	△
	300 2x4 (Man. Hand Brake)	98 - 04							827		△			
	300 2x4/4x4	98 - 04	758*		△	△	△		758		△	△	△	
	300 4x4	05 - 05	822*		△	△	△	△	822		△	△	△	△
	300 4x4 (Man. Hand Brake)	98 - 05							827		△			
	300 DVX	09 - 16	810*	△		△	△		775	△		△	△	
	375 2x4/4x4	02 - 02	758*		△	△	△		758		△	△	△	
	375 2x4/4x4 (Man. Hand Brake)	02 - 02							827		△			
	400 2x4 (Man. Hand Brake)	98 - 02							827		△			
	400 2x4/4x4	98 - 04	758*		△	△	△		758		△	△	△	
	400 2x4/4x4 (FIS)	02 - 04	758*		△	△	△		758		△	△	△	
	400 2x4/4x4 (FIS)	05 - 07	822*		△	△	△	△	822		△	△	△	△
	400 2x4/4x4 (FIS) Aut. (Man. Hand Brake)	03 - 04							827		△			
	400 2x4/4x4 (FIS)(Man. Hand Brake)	02 - 04							827		△			
	400 2x4/4x4 (FIS)(Man. Hand Brake)	05 - 08							758		△	△	△	
	400 4x4 (Man. Hand Brake)	98 - 04							827		△			
	400 DVX	04 - 08	592*	△		△	△		649	△		△	△	
	400 TBX 4x4	04 - 04	758*		△	△	△		758		△	△	△	
	400 TBX 4x4 (Man. Hand Brake)	04 - 04							827		△			
TRV	400	09 - 13	822*		△	△	△	△	822		△	△	△	△
	440 Bear Cat	96 - 97							758		△	△	△	
	450 H1	10 - 10	822*		△	△	△	△	822		△	△	△	△
XC	450	11 - 14	822*		△	△	△	△	822		△	△	△	△
	454 Arctic Cat 4x4	98 - 98	758*		△	△	△		758		△	△	△	
	454 Bear Cat 2x4/4x4	96 - 98	758*		△	△	△		758		△	△	△	
	454 Bear Cat 2x4/4x4 (Man. Hand Brake)	98 - 98							827		△			
	500 2x4 (FIS)(Man. Hand Brake)	02 - 02							827		△			
	500 2x4 (Man. Hand Brake)	02 - 02							827		△			
	500 2x4/4x4	98 - 04	758*		△	△	△		758		△	△	△	
	500 2x4/4x4 (FIS)	02 - 04	758*		△	△	△		758		△	△	△	
	500 2x4/4x4 (FIS)	05 - 09	822*		△	△	△	△	822		△	△	△	△
	500 4x4 (FIS) Aut.(Man. Hand Brake)	02 - 03							827		△			
	500 4x4 (FIS)(Man. Hand Brake)	02 - 03							827		△			
	500 4x4 (Man. Hand Brake)	98 - 02							827		△			
	500 TBX 4x4	02 - 04	758*		△	△	△		758		△	△	△	
	500 TBX 4x4	05 - 06	822*		△	△	△	△	822		△	△	△	△
	500 TBX 4x4 (Man. Hand Brake)	03 - 04							827		△			
	500 TBX 4x4 Aut.(Man. Hand Brake)	02 - 02							827		△			
	500 TRV 4x4	03 - 04	758*		△	△	△		758		△	△	△	
	500 TRV 4x4	05 - 06	822*		△	△	△	△	822		△	△	△	△
	500 TRV 4x4 (Man. Hand Brake)	03 - 04							827		△			
	550 H1	09 - 13	822*		△	△	△	△	822		△	△	△	△
	550 LTD	09 - 12	822*		△	△	△	△	822		△	△	△	△
	550 Prowler	09 - 14	822*		△	△	△	△	822		△	△	△	△
TRV	550	09 - 14	822*		△	△	△	△	822		△	△	△	△
	650 H1 4x4 Aut.	05 - 11	822*		△	△	△	△	822		△	△	△	△
	650 Prowler	06 - 08	822*		△	△	△	△	822		△	△	△	△

Applications  
ATV/UTV

\* = 2 sets required / 2 jeux pour l'Avant.  
△ = Available quality / Qualité disponible.

To select compound for off-road front/rear - see page 21-23 / Pour sélectionner vos plaquettes off-road avant/arrière - voir page 21-23.

**COMPOUND CHOICE**5xx - 9xx = ATV/UTV Brake Pads  
2xxx = Brake Shoes**COMPOUND CHOICE**5xx - 9xx = ATV/UTV Brake Pads  
2xxx = Brake Shoes

ARCTIC CAT				HF	ATS	SI	RSI	PSI		HF	ATS	SI	RSI	PSI
650 V2 4x4 Aut.	05 - 06	822*		△	△	△	△	822		△	△	△	△	△
650 V2 4x4 Aut. LE	05 - 06	822*		△	△	△	△	822		△	△	△	△	△
700 Diesel	06 - 14	822*		△	△	△	△	822		△	△	△	△	△
700 H1	09 - 10	822*		△	△	△	△	822		△	△	△	△	△
700 Prowler	08 - 08	822*		△	△	△	△	822		△	△	△	△	△
700 Wildcat Sport	15 - 18	946*		△	△	△		822		△	△	△	△	△
700 Wildcat Sport LTD.	16 - 18	946*		△	△	△		822		△	△	△	△	△
700 Wildcat Sport LTD. EPS	17 - 18	946*		△	△	△		822		△	△	△	△	△
700 Wildcat Sport XT	15 - 18	946*		△	△	△		822		△	△	△	△	△
700 Wildcat Sport XT EPS	16 - 18	946*		△	△	△		822		△	△	△	△	△
TBX 700	12 - 14	822*		△	△	△	△	822		△	△	△	△	△
TRV 700	09 - 12	822*		△	△	△	△	822		△	△	△	△	△
1000 Prowler	09 - 09	822*		△	△	△	△	822		△	△	△	△	△
1000 Thundercat	09 - 14	822*		△	△	△	△	822		△	△	△	△	△
1000 Wildcat 4X	16 - 18	912*		△	△	△		822		△	△	△	△	△
1000 Wildcat X	16 - 18	912*		△	△	△		822		△	△	△	△	△
1000 Wildcat X Ltd.	17 - 18	912*		△	△	△		822		△	△	△	△	△
1000 Wildcat X SE	17 - 18	912*		△	△	△		822		△	△	△	△	△
TRV 1000	09 - 14	822*		△	△	△	△	822		△	△	△	△	△
<b>BOMBARDIER</b>														
50 Quest	03 - 04	2048*						2041						
DS 50	02 - 06	2048*						2041						
90 Quest	03 - 04	2048*						2041						
DS 90	02 - 06	2048*						2041						
200 Rally 2x4	03 - 04	544*		△		△								
200 Rally 2x4	05 - 06	544*		△		△		546		△		△	△	
DS 250 Left	06 - 06	754		△		△	△	754		△		△	△	△
DS 250 Right	06 - 06	767				△	△							
330 Outlander Left	03 - 06	754		△		△	△	754		△		△	△	△
330 Outlander Right	03 - 06	767				△	△							
400 Outlander Left	03 - 06	754		△		△	△	754		△		△	△	△
400 Outlander Right	03 - 06	767				△	△							
400 Outlander Max Left	03 - 06	754		△		△	△	754		△		△	△	△
400 Outlander Max Right	03 - 06	767				△	△							
500 Quest Left	02 - 06	754		△		△	△	754		△		△	△	△
500 Quest Right	02 - 06	767				△	△							
500 Traxter 4x4	99 - 00	730*		△				730		△				
500 Traxter 4x4 Left	01 - 06	754		△		△	△	767				△	△	△
500 Traxter 4x4 Right	01 - 06	767				△	△							
500 Traxter Max Left	03 - 05	754		△		△	△	767				△	△	△
500 Traxter Max Right	03 - 05	767				△	△							
650 Quest Left	02 - 06	754		△		△	△	754		△		△	△	△
650 Quest Right	02 - 06	767				△	△							
650 Quest Max Left	03 - 06	754		△		△	△	767				△	△	△
650 Quest Max Right	03 - 06	767				△	△							
650 Traxter Max Left	03 - 05	754		△		△	△	767				△	△	△
650 Traxter Max Right	03 - 05	767				△	△							
DS 650 Left	01 - 06	754		△		△	△	754		△		△	△	△
DS 650 Right	01 - 06	767				△	△							
800 Outlander Left	06 - 06	754		△		△	△	754		△		△	△	△
800 Outlander Right	06 - 06	767				△	△							
800 Outlander XT Left	06 - 06	754		△		△	△	754		△		△	△	△
800 Outlander XT Right	06 - 06	767				△	△							
<b>CAN-AM</b>														
DS 50	07 - 11	2048*						2041						
DS 70	08 - 14	2048*						2041						
DS 90	07 - 18	2048*						2041						
DS 90 X	08 - 18	544*		△		△		544		△		△	△	
DS 250	08 - 18	810*		△		△		810		△		△	△	
400 Outlander EFi Left	09 - 14	754		△		△	△	754		△		△	△	△
400 Outlander EFi Right	09 - 14	767				△	△							
400 Outlander MAX STD Left	07 - 13	754		△		△	△	754		△		△	△	△
400 Outlander MAX STD Right	07 - 13	767				△	△							
400 Outlander MAX XT Left	07 - 13	754		△		△	△	754		△		△	△	△
400 Outlander MAX XT Right	07 - 13	767				△	△							
400 Outlander STD Left	07 - 14	754		△		△	△	754		△		△	△	△

Applications  
ATV/UTV\* = 2 sets required / 2 jeux pour l'Avant.  
△ = Available quality / Qualité disponible.

**COMPOUND CHOICE**5xx - 9xx = ATV/UTV Brake Pads  
2xxx = Brake Shoes**COMPOUND CHOICE**5xx - 9xx = ATV/UTV Brake Pads  
2xxx = Brake Shoes

CAN-AM				HF	ATS	SI	RSI	PSI		HF	ATS	SI	RSI	PSI
400	Outlander STD Right	07 - 14	767			△	△	△						
400	Outlander XT Left	07 - 14	754	△		△	△	△	754	△		△	△	△
400	Outlander XT Right	07 - 14	767			△	△	△						
450	Outlander Left	15 - 18	911			△	△							
450	Outlander Right	15 - 18	910			△	△		910			△	△	
450	Outlander MAX Left	15 - 18	911			△	△							
450	Outlander MAX Right	15 - 18	910			△	△		910			△	△	
DS	450	08 - 12	907*			△	△		908			△	△	
500	Outlander Left	13 - 14	911			△	△							
500	Outlander Right	13 - 14	910			△	△		910			△	△	
500	Outlander MAX Left	13 - 14	911			△	△							
500	Outlander MAX Right	13 - 14	910			△	△		910			△	△	
500	Outlander MAX STD Left	07 - 12	754	△		△	△	△	754	△		△	△	△
500	Outlander MAX STD Right	07 - 12	767			△	△	△						
500	Outlander MAX XT Left	07 - 12	754	△		△	△	△	754	△		△	△	△
500	Outlander MAX XT Right	07 - 12	767			△	△	△						
500	Outlander STD Left	07 - 12	754	△		△	△	△	754	△		△	△	△
500	Outlander STD Right	07 - 12	767			△	△	△						
500	Outlander XT Left	07 - 12	754	△		△	△	△	754	△		△	△	△
500	Outlander XT Right	07 - 12	767			△	△	△						
500	Renegade Left	08 - 11	754	△		△	△	△	754	△		△	△	△
500	Renegade Right	08 - 11	767			△	△	△						
500	Renegade Left	12 - 13	911			△	△							
500	Renegade Right	12 - 13	910			△	△		910			△	△	
500	Renegade Left	14 - 14	911			△	△		911			△	△	
500	Renegade Right	14 - 14	910			△	△		910			△	△	
650	Outlander Left	13 - 15	911			△	△							
650	Outlander Right	13 - 15	910			△	△		910			△	△	
650	Outlander 6x6 Left	14 - 18	911			△	△		911			△	△	
650	Outlander 6x6 Right	14 - 18	910			△	△		910			△	△	
650	Outlander MAX Left	13 - 15	911			△	△							
650	Outlander MAX Right	13 - 15	910			△	△		910			△	△	
650	Outlander MAX STD Left	07 - 12	754	△		△	△	△	754	△		△	△	△
650	Outlander MAX STD Right	07 - 12	767			△	△	△						
650	Outlander MAX XT Left	07 - 12	754	△		△	△	△	754	△		△	△	△
650	Outlander MAX XT Right	07 - 12	767			△	△	△						
650	Outlander STD Left	07 - 12	754	△		△	△	△	754	△		△	△	△
650	Outlander STD Right	07 - 12	767			△	△	△						
650	Outlander XT Left	07 - 12	754	△		△	△	△	754	△		△	△	△
650	Outlander XT Right	07 - 12	767			△	△	△						
800	Commander Left	11 - 14	638	△		△	△	△	611	△		△	△	△
800	Commander Right	11 - 14	611	△		△	△	△						
800	Commander MAX R EFI Left	18 - 20	971			△	△	△	754	△		△	△	△
800	Commander MAX R EFI Right	18 - 20	972			△	△	△						
800	Commander R EFI Left	18 - 18	971			△	△	△	754	△		△	△	△
800	Commander R EFI Right	18 - 18	972			△	△	△						
800	Outlander Left	12 - 15	911			△	△							
800	Outlander Right	12 - 15	910			△	△		910			△	△	
800	Outlander MAX Left	13 - 14	911			△	△							
800	Outlander MAX Right	13 - 14	910			△	△		910			△	△	
800	Outlander MAX LTD Left	07 - 11	754	△		△	△	△	754	△		△	△	△
800	Outlander MAX LTD Right	07 - 11	767			△	△	△						
800	Outlander MAX STD Left	07 - 11	754	△		△	△	△	754	△		△	△	△
800	Outlander MAX STD Right	07 - 11	767			△	△	△						
800	Outlander MAX XT Left	07 - 11	754	△		△	△	△	754	△		△	△	△
800	Outlander MAX XT Right	07 - 11	767			△	△	△						
800	Outlander STD Left	07 - 11	754	△		△	△	△	754	△		△	△	△
800	Outlander STD Right	07 - 11	767			△	△	△						
800	Outlander XT Left	07 - 11	754	△		△	△	△	754	△		△	△	△
800	Outlander XT Right	07 - 11	767			△	△	△						
800	Renegade Left	08 - 11	754	△		△	△	△	754	△		△	△	△
800	Renegade Right	08 - 11	767			△	△	△						
800	Renegade Left	12 - 13	911			△	△							
800	Renegade Right	12 - 13	910			△	△		910			△	△	
800	Renegade Left	14 - 15	911			△	△		911			△	△	
800	Renegade Right	14 - 15	910			△	△		910			△	△	
800	Renegade EFI Left	07 - 11	754	△		△	△	△	754	△		△	△	△
800	Renegade EFI Right	07 - 11	767			△	△	△						

Applications  
ATV/UTV

\* = 2 sets required / 2 jeux pour l'Avant.

△ = Available quality / Qualité disponible.

To select compound for off-road front/rear - see page 21-23 / Pour sélectionner vos plaquettes off-road avant/arrière - voir page 21-23.

**COMPOUND CHOICE**5xx - 9xx = ATV/UTV Brake Pads  
2xxx = Brake Shoes**COMPOUND CHOICE**5xx - 9xx = ATV/UTV Brake Pads  
2xxx = Brake Shoes

CAN-AM				HF	ATS	SI	RSI	PSI	HF	ATS	SI	RSI	PSI
800 Renegade X Left	08 - 11	754	△		△	△	△	754	△		△	△	△
800 Renegade X Right	08 - 11	767			△	△	△						
900 X3 Left	17 - 19	957			△	△	△	957			△	△	△
900 X3 Right	17 - 19	956			△	△	△	956			△	△	△
900 X3 MAX Left	17 - 19	957			△	△	△	957			△	△	△
900 X3 MAX Right	17 - 19	956			△	△	△	956			△	△	△
900 X3 MAX Turbo Left	18 - 19	957			△	△	△	957			△	△	△
900 X3 MAX Turbo Right	18 - 19	956			△	△	△	956			△	△	△
900 X3 MAX Turbo R Left	18 - 19	957			△	△	△	957			△	△	△
900 X3 MAX Turbo R Right	18 - 19	956			△	△	△	956			△	△	△
900 X3 Turbo Left	18 - 19	957			△	△	△	957			△	△	△
900 X3 Turbo Right	18 - 19	956			△	△	△	956			△	△	△
900 X3 Turbo R Left	18 - 19	957			△	△	△	957			△	△	△
900 X3 Turbo R Right	18 - 19	956			△	△	△	956			△	△	△
1000 Commander Left	16 - 17	971			△	△	△	754	△		△	△	△
1000 Commander Right	16 - 17	972			△	△	△						
1000 Commander MAX Left	14 - 17	971			△	△	△	754	△		△	△	△
1000 Commander MAX Right	14 - 17	972			△	△	△						
1000 Commander MAX R EFI Left	18 - 19	971			△	△	△	754	△		△	△	△
1000 Commander MAX R EFI Right	18 - 19	972			△	△	△						
1000 Commander R EFI Left	18 - 20	971			△	△	△	754	△		△	△	△
1000 Commander R EFI Right	18 - 20	972			△	△	△						
1000 Maverick Left	14 - 18	971			△	△	△	754	△		△	△	△
1000 Maverick Right	14 - 18	972			△	△	△						
1000 Maverick MAX Left	14 - 18	971			△	△	△	754	△		△	△	△
1000 Maverick MAX Right	14 - 18	972			△	△	△						
1000 Outlander Left	12 - 15	910			△	△		910			△	△	
1000 Outlander Right	12 - 15	911			△	△							
1000 Outlander 6x6 Left	14 - 18	911			△	△		911			△	△	
1000 Outlander 6x6 Right	14 - 18	910			△	△		910			△	△	
1000 Outlander MAX Left	12 - 18	911			△	△							
1000 Outlander MAX Right	12 - 18	910			△	△		910			△	△	
1000 Renegade Left	12 - 13	911			△	△							
1000 Renegade Right	12 - 13	910			△	△		910			△	△	
1000 Renegade Left	14 - 18	911			△	△		911			△	△	
1000 Renegade Right	14 - 18	910			△	△		910			△	△	
<b>CANNONDALE</b>													
440 Blaze Left	03 - 03	754			△	△	△	754	△		△	△	△
440 Blaze Right	03 - 03	767			△	△	△						
440 Cannibal Left	03 - 03	754			△	△	△	754	△		△	△	△
440 Cannibal Right	03 - 03	767			△	△	△						
440 Glamis Left	03 - 03	754			△	△	△	754	△		△	△	△
440 Glamis Right	03 - 03	767			△	△	△						
440 Moto Left	03 - 03	754			△	△	△	754	△		△	△	△
440 Moto Right	03 - 03	767			△	△	△						
440 Speed Left	03 - 03	754			△	△	△	754	△		△	△	△
440 Speed Right	03 - 03	767			△	△	△						
<b>CECTEK</b>													
500 EFI Gladiator	09 - 13	810*			△	△		544	△		△	△	
500 EFI King Cobra	09 - 13	878*			△	△	△	544	△		△	△	
500 EFI Quadrift	09 - 11	878*			△	△	△	544	△		△	△	
500 i Estoc	10 - 10	878*			△	△	△	544	△		△	△	
<b>CF MOTO</b>													
400 C-Force	18 - 21	986*			△		△	799			△	△	
450 C-Force L	16 - 17	914*			△	△		799			△	△	
450 G-Force L	16 - 17	914*			△	△		799			△	△	
500 C-Force HO	18 - 18	986*			△		△	799			△	△	
500 C-Force S	18 - 21	986*			△		△	799			△	△	
500 U-Force	18 - 20	986*			△		△	987			△		△
500 Z-Force	18 - 21	986*			△		△	987			△		△
CF 500 Terralander	13 - 15	914*			△	△		799			△	△	
550 C-Force	16 - 17	914*			△	△		799			△	△	
550 U-Force Left	15 - 16	638			△	△	△						
550 U-Force Right	15 - 16	611			△	△	△						
550 Z-Force Left	15 - 16	638			△	△	△						

Applications  
ATV/UTV\* = 2 sets required / 2 jeux pour l'Avant.  
△ = Available quality / Qualité disponible.

**COMPOUND CHOICE**5xx - 9xx = ATV/UTV Brake Pads  
2xxx = Brake Shoes**COMPOUND CHOICE**5xx - 9xx = ATV/UTV Brake Pads  
2xxx = Brake Shoes

CF MOTO				HF	ATS	SI	RSI	PSI		HF	ATS	SI	RSI	PSI
	550 Z-Force Right	15 - 16	611	△		△	△	△						
	600 C-Force	19 - 19	986*			△		△	799			△	△	
	600 C-Force	20 - 21	986*			△		△	987			△		△
	600 C-Force Touring	20 - 21	986*			△		△	987			△		△
CF	625 Terralander	11 - 15	914*			△	△		799			△	△	
	800 U-Force	18 - 21	986*			△		△	987			△		△
	800 Z-Force EX Left	15 - 15	638	△		△	△	△						
	800 Z-Force EX Right	15 - 15	611	△		△	△	△						
	800 Z-Force EX	18 - 21	986*			△		△	987			△		△
	800 Z-Force Trail	18 - 21	986*			△		△	987			△		△
CF	800 Terralander	12 - 14	914*			△	△		799			△	△	
	1000 Z-Force	18 - 19	986*			△		△	987			△		△
CPI														
	250 XS ATV	07 - 08	810*	△		△	△							
XS	250 Quad	06 - 08	544*	△		△	△		848	△		△		
DERBI														
DXR	200 Quad (Front disc)	04 - 07	544*	△		△	△		586	△		△	△	
DXR	200 Quad (Front drum)	04 - 05	2028						586	△		△	△	
DXR	200 Quad (Front drum)	04 - 05	2028						611	△		△	△	△
DXR	250 Quad (Front disc)	04 - 07	544*	△		△	△		586	△		△	△	
DXR	250 Quad (Front drum)	04 - 05	2028						586	△		△	△	
DXR	250 Quad (Front drum)	04 - 05	2028						611	△		△	△	△
E-TON														
RXL	150 Viper	07 - 07	2012*						847	△		△	△	
VXL	250 Vector, ST Vector	06 - 07	544*	△		△	△		847	△		△	△	
VTX	300 Vortex, ST Vortex	07 - 07	544*	△		△	△		847	△		△	△	
VXL	300 Vector, ST Vector	07 - 13	544*	△		△	△		847	△		△	△	
GAS GAS														
	50 Wild HP	04 - 07	671*	△		△	△		671	△		△	△	
	200 Wild HP	08 - 09	671*	△		△	△		671	△		△	△	
	240 Wild HP	04 - 06	671*	△		△	△		671	△		△	△	
	250 Wild HP	08 - 08	671*	△		△	△		671	△		△	△	
	300 Wild HP	03 - 05	671*	△		△	△		671	△		△	△	
	450 Wild HP	03 - 09	671*	△		△	△		671	△		△	△	
	515 Wild HP	09 - 09	671*	△		△	△		671	△		△	△	
GOES														
	360 Max	08 - 14	914*			△	△							
	520 Max	07 - 12	914*			△	△		799			△	△	
G	520	07 - 12	914*			△	△		799			△	△	
G	525	12 - 14	914*			△	△		799			△	△	
G	620	11 - 14	914*			△	△		799			△	△	
G	625 A	12 - 14	914*			△	△		799			△	△	
HISUN														
HS	400 UTV Left	15 - 17	638	△		△	△	△	767			△	△	△
HS	400 UTV Right	15 - 17	611	△		△	△	△						
HS	500 UTV Left	15 - 17	638	△		△	△	△	767			△	△	△
HS	500 UTV Right	15 - 17	611	△		△	△	△						
HS	700 UTV Left	15 - 17	638	△		△	△	△	767			△	△	△
HS	700 UTV Right	15 - 17	611	△		△	△	△						
HS	700 UTV (2 cal.rear) Left	15 - 17	638	△		△	△	△	638	△		△	△	△
HS	700 UTV (2 cal.rear) Right	15 - 17	611	△		△	△	△	611	△		△	△	△
HS	800 UTV (2 cal.rear) Left	15 - 17	638	△		△	△	△	638	△		△	△	△
HS	800 UTV (2 cal.rear) Right	15 - 17	611	△		△	△	△	611	△		△	△	△
HONDA														
ATC	70 all models	78 - 85							2069					
ATC	70 K1	76 - 77							2012					
TRX	70	86 - 87	2048*						2041					
ATC	80	76 - 78							2019					
ATC	90 K1, K2, K3	73 - 78							2019					
TRX	90	93 - 01	2012*						2019					
ATC	110 all models	79 - 85							2019					

Applications  
ATV/UTV

\* = 2 sets required / 2 jeux pour l'Avant.

△ = Available quality / Qualité disponible.

To select compound for off-road front/rear - see page 21-23 / Pour sélectionner vos plaquettes off-road avant/arrière - voir page 21-23.

**COMPOUND CHOICE**5xx - 9xx = ATV/UTV Brake Pads  
2xxx = Brake Shoes**COMPOUND CHOICE**5xx - 9xx = ATV/UTV Brake Pads  
2xxx = Brake Shoes

HONDA					HF	ATS	SI	RSI	PSI		HF	ATS	SI	RSI	PSI
ATC	125	ME, MF, MG, MH	84 - 87	2012						2019					
TRX	125		85 - 88	2012*						2019					
ATC	185	A, S, SB	80 - 83	2012						2019					
ATC	200		81 - 83	2012						2019					
ATC	200	E Big Red	82 - 83	2012						2019					
ATC	200	ES Big Red	84 - 84	2012						2019					
ATC	200	M	84 - 85	2012						2019					
ATC	200	S	84 - 86	2012						2019					
ATC	200	X	83 - 85	592	△		△	△		562	△		△	△	
ATC	200	X	86 - 87	592	△		△	△		592	△		△	△	
TLR	200	Fatcat	86 - 87	2013						2013					
TLR	200	G, H	86 - 87	2013						2057					
TR	200		86 - 87	2013						2013					
TRX	200		84 - 84	2044*						2019					
TRX	200		90 - 91	2083*						2019					
TRX	200	D Type II	91 - 97	2083*						2019					
TRX	200	SX	86 - 88	2083*						2019					
ATC	250	ES, SX	85 - 87	2019						2024					
ATC	250	R	81 - 81	536	△		△	△		2014					
ATC	250	R	82 - 84	584	△		△	△		562	△		△	△	
ATC	250	R	85 - 86	558	△		△	△		558	△		△	△	
ATC	250	X	85 - 85	558	△		△	△		562	△		△	△	
FL	250	Odyssey	77 - 84	525	△					2019					
TL	250		75 - 76	2013						2013					
TRX	250		85 - 87	2044*						2024					
TRX	250	EX Sportrax	01 - 08	592*	△		△	△		2055					
TRX	250	R	86 - 89	603*			△	△		558	△		△	△	
TRX	250	R Fourtrax	88 - 88	603*			△	△		558	△		△	△	
TRX	250	Recon	97 - 14	2083*						2055					
TRX	250	X	08 - 13	592*	△		△	△		2055					
TRX	250	X Fourtrax	87 - 87	603*			△	△		558	△		△	△	
TRX	250	X Fourtrax	88 - 92	584*	△		△	△		584	△		△	△	
TRX	300		88 - 00							2024					
TRX	300	4WD	88 - 00	2085*						2024					
TRX	300	EX	93 - 00	592*	△		△	△		562	△		△	△	
TRX	300	EX Sportrax	01 - 08	592*	△		△	△		592	△		△	△	
TRX	300	X	09 - 09	592*	△		△	△		592	△		△	△	
ATC	350	Odyssey	85 - 85	558	△		△	△		562	△		△	△	
ATC	350	X	85 - 85	558	△		△	△		562	△		△	△	
ATC	350	X	86 - 89	603			△	△		562	△		△	△	
FL	350	R Odyssey	85 - 87	2044*						610	△				
TRX	350	all models	86 - 89	2045						2046					
TRX	350	Rancher /ES 2x4, 4x4	00 - 09	2085*						2207					
FL	400	R Pilot	89 - 90	2044*						610	△				
TRX	400	AT	04 - 11	2085*						2207					
TRX	400	EX Sportrax	01 - 08	592*	△		△	△		592	△		△	△	
TRX	400	Fourtrax EX	99 - 00	592*	△		△	△		592	△		△	△	
TRX	400	FW Fourtrax Foreman	95 - 02	2085*						2207					
TRX	400	X	09 - 12	592*	△		△	△		592	△		△	△	
TRX	420	FA / FPA	09 - 13	592*	△		△	△		813			△	△	
TRX	420	FPE / FPM 4x4	09 - 14	592*	△		△	△					△	△	
TRX	450	EX Sportrax	01 - 05	592*	△		△	△		592	△		△	△	
TRX	450	Foreman ES, Foreman S	98 - 04	2085*						2207					
TRX	450	R	04 - 09	694*	△		△	△		813			△	△	
	500	Pioneer	15 - 20	982*			△	△	△	976			△	△	△
TRX	500	all models	05 - 14	829*			△			2046					
TRX	500	Foreman, Rubicon	00 - 09	2085*						2072					
TRX	650	FA Rincon	03 - 05	2085*						813			△	△	
TRX	650	FGA Rincon	04 - 05	2085*						813			△	△	
TRX	680	FA6 Rincon	06 - 15	829*			△			813			△	△	
TRX	680	FGA6 Rincon	06 - 15	829*			△			813			△	△	
	700	Pioneer	14 - 21	982*			△	△	△	976			△	△	△
TRX	700	XX	08 - 12	694*	△		△	△		829			△	△	
	1000	Pioneer	16 - 21	981*			△	△	△	975			△	△	△
	1000	Talon	21 - 21	981*			△	△	△	975			△	△	△
	1000	Talon R	19 - 21	981*			△	△	△	975			△	△	△
	1000	Talon X	19 - 21	981*			△	△	△	975			△	△	△
	1000	Talon X-4	20 - 20	981*			△	△	△	975			△	△	△

Applications  
ATV/UTV

\* = 2 sets required / 2 jeux pour l'Avant.

△ = Available quality / Qualité disponible.

To select compound for off-road front/rear - see page 21-23 / Pour sélectionner vos plaquettes off-road avant/arrière - voir page 21-23.

**COMPOUND CHOICE**5xx - 9xx = ATV/UTV Brake Pads  
2xxx = Brake Shoes**COMPOUND CHOICE**5xx - 9xx = ATV/UTV Brake Pads  
2xxx = Brake Shoes

HYOSUNG				HF	ATS	SI	RSI	PSI		HF	ATS	SI	RSI	PSI
TE	400	05 - 06	536*	△		△	△		649	△		△	△	
TE	450	07 - 11	536*	△		△	△		649	△		△	△	
JOHN DEERE														
HPX	350 Gator	10 - 14	908*			△	△		908			△	△	
	500 Buck Left	05 - 05	754	△		△	△	△	767			△	△	△
	500 Buck Right	05 - 05	767			△	△	△						
	500 Buck EX, EXT Left	05 - 05	754	△		△	△	△	767			△	△	△
	500 Buck EX, EXT Right	05 - 05	767			△	△	△						
	500 Trail Buck Left	05 - 05	754	△		△	△	△	767			△	△	△
	500 Trail Buck Right	05 - 05	767			△	△	△						
XUV	625 Gator	11 - 11	912*		△	△	△							
	650 Trail Buck Left	05 - 05	754	△		△	△	△	767			△	△	△
	650 Trail Buck Right	05 - 05	767			△	△	△						
	650 Trail Buck EX, EXT Left	05 - 05	754	△		△	△	△	767			△	△	△
	650 Trail Buck EX, EXT Right	05 - 05	767			△	△	△						
XUV	825 Gator	11 - 11	912*		△	△	△							
XUV	855 D Gator	11 - 11	912*		△	△	△							
KAWASAKI														
KLF	110 Mojave	87 - 88	2015*						2183					
KLT	110	84 - 86	2015						2183					
KLT	160	85 - 85	2015						2183					
KLF	185 Bayou	85 - 85							2038					
KLF	185 Bayou	86 - 88	2040*						2038					
KLT	185	86 - 87	2015						2183					
KLT	200	81 - 84	2015						2040					
KLF	220 Bayou	88 - 02	2040*						2038					
KLT	250	82 - 83	2015						2040					
KLT	250 Police	84 - 84	2015						2040					
KLT	250 Prairie	83 - 85	2015						2040					
KSF	250 Mojave	87 - 02	591*	△		△	△		592	△		△	△	
KXF	250 Tecate	87 - 88	591*	△		△	△		592	△		△	△	
KXT	250 Tecate	84 - 84	2040						544	△		△	△	
KXT	250 Tecate	85 - 86	546	△		△	△		586	△		△	△	
KXT	250 Tecate	87 - 88	591	△		△	△		592	△		△	△	
KAF	300 Mule 500	92 - 95	2053*											
KAF	300 Mule 550	03 - 05	2053*											
KEF	300 Lakota	95 - 04	591*	△		△	△		592	△		△	△	
KLF	300 Bayou	86 - 87	2054*						2038*		△	△	△	
KLF	300 Bayou	88 - 04	546*	△		△	△		2038*					
KLF	300 Bayou 4x4 Left	89 - 05	611	△		△	△	△	2197					
KLF	300 Bayou 4x4 Right	89 - 05	638	△		△	△	△						
KVF	300 Brute Force	13 - 17	810*	△		△	△		810	△		△	△	
KVF	300 Prairie	99 - 02	536*	△		△	△							
KVF	300 Prairie 4x4	99 - 05	536*	△		△	△							
KVF	360 Prairie 2x4, 4x4	03 - 08	536*	△		△	△							
KFX	400	02 - 05	592*	△		△	△		649	△		△	△	
KLF	400 Bayou Left	93 - 99	611	△		△	△	△	2197					
KLF	400 Bayou Right	93 - 99	638	△		△	△	△						
KVF	400 Prairie	97 - 98	536*	△		△	△		2197					
KVF	400 Prairie 2x4	99 - 01	536*	△		△	△							
KVF	400 Prairie 4x4	99 - 02	536*	△		△	△							
KFX	450 Left	07 - 15	801			△	△		592	△		△	△	
KFX	450 Right	07 - 15	798			△	△							
KVF	650 Brute Force 4x4 Left	05 - 11	801			△	△							
KVF	650 Brute Force 4x4 Right	05 - 11	798			△	△							
KVF	650 Brute Force 4x4i Left	05 - 11	611	△		△	△	△						
KVF	650 Brute Force 4x4i Right	05 - 11	638	△		△	△	△						
KVF	650 Prairie Left	01 - 03	801			△	△							
KVF	650 Prairie Right	01 - 03	798			△	△							
KFX	700 V-Force Left	04 - 13	801			△	△							
KFX	700 V-Force Right	04 - 13	798			△	△							
KSV	700 V-Force Left	04 - 11	801			△	△							
KSV	700 V-Force Right	04 - 11	798			△	△							
KVF	700 Prairie Left	04 - 13	801			△	△							
KVF	700 Prairie Right	04 - 13	798			△	△							
KRF	750 Teryx 4x4 Left	08 - 13	611	△		△	△	△						

Applications  
ATV/UTV

\* = 2 sets required / 2 jeux pour l'Avant.

△ = Available quality / Qualité disponible.

To select compound for off-road front/rear - see page 21-23 / Pour sélectionner vos plaquettes off-road avant/arrière - voir page 21-23.



**COMPOUND CHOICE**5xx - 9xx = ATV/UTV Brake Pads  
2xxx = Brake Shoes**COMPOUND CHOICE**5xx - 9xx = ATV/UTV Brake Pads  
2xxx = Brake Shoes

KAWASAKI					HF	ATS	SI	RSI	PSI		HF	ATS	SI	RSI	PSI	
KRF	750	Teryx 4x4 Left	08 - 13	638	△		△	△	△							
KVF	750	Brute Force 4x4i Left	05 - 15	611	△		△	△	△							
KVF	750	Brute Force 4x4i Right	05 - 15	638	△		△	△	△							
	800	Mule Pro FX Left	15 - 17	611	△		△	△	△							
	800	Mule Pro FX Right	15 - 17	638	△		△	△	△							
KRF	800	Teryx BEF/CEF/DEF Left	14 - 17	611	△		△	△	△							
KRF	800	Teryx BEF/CEF/DEF Right	14 - 17	638	△		△	△	△							
KRT	800	Teryx 4 BEF/CEF/DEF Left	14 - 17	611	△		△	△	△							
KRT	800	Teryx 4 BEF/CEF/DEF Right	14 - 17	638	△		△	△	△							
<b>KTM</b>																
SX	450	ATV	08 - 10	866*			△	△		867			△	△		
XC	450	ATV	08 - 10	866*			△	△		867			△	△		
SX	505	ATV	08 - 12	866*			△	△		867			△	△		
XC	505	ATV	08 - 12	866*			△	△		867			△	△		
<b>KYMCO</b>																
	50	MXU	05 - 10	2012*						749	△					
	150	MXU	05 - 17	2012*						749	△					
	250	MXU	06 - 14	810*	△		△	△		775	△		△	△		
	250	Urban Quad	06 - 06	810*	△		△	△		775	△		△	△		
KXR	250		04 - 14	810*	△		△	△		775	△		△	△		
	300	Maxxer	06 - 13	810*	△		△	△		775	△		△	△		
	300	Maxxer Supermoto	15 - 15	810*	△		△	△		775	△		△	△		
	300	MXU	06 - 17	810*	△		△	△		810	△		△	△		
	400	Maxxer	08 - 10	822*		△	△	△	△	822		△	△	△	△	
	400	Maxxer (Parking Brake)	08 - 10							921	△					
	400	MXU	08 - 11	822*		△	△	△	△	822		△	△	△	△	
	400	MXU (Parking Brake)	08 - 11							921	△					
	450	i Maxxer	10 - 14	822*		△	△	△	△	822		△	△	△	△	
	450	i Maxxer (Parking Brake)	10 - 14							921	△					
	450	i MXU	11 - 14	822*		△	△	△	△	822		△	△	△	△	
	450	i MXU (Parking Brake)	11 - 14							921	△					
	500	MXU	06 - 08	810*	△		△	△		810	△		△	△		
	500	MXU	09 - 14	945*			△	△								
	500	MXU DX	11 - 13	945*			△	△								
	500	UXV 4x4	08 - 14	810*	△		△	△		810	△		△	△		
	550	MXU	12 - 20	945*			△	△		810	△		△	△		
	700	MXU	13 - 20	945*			△	△		810	△		△	△		
UXV	700		14 - 16	945*			△	△								
<b>LAVERDA</b>																
HP	125	Quasar	04 - 04							758		△	△	△		
HP	180	Quasar	04 - 04							758		△	△	△		
	400	Quasar 4x4	04 - 04	758*		△	△	△		758		△	△	△		
	500	Quasar 4x4	04 - 04	758*		△	△	△		758		△	△	△		
	500	Quasar 4x4 C	04 - 04	758*		△	△	△		758		△	△	△		
<b>POLARIS</b>																
	EV-LSV		10 - 11	897*		△	△	△	△	800			△	△	△	
	LSV 4x4		11 - 12	897*		△	△	△	△	800			△	△	△	
	Ranger 48v EV		13 - 18	897*		△	△	△	△	800			△	△	△	
	50 Predator		04 - 14	2048*												
	50 Scrambler		01 - 03	2048*												
	90 Predator		03 - 14	2043*												
	90 Scrambler		01 - 03	2048*												
	90 Sportsman		01 - 15	2048*												
	170 Ranger RZR		09 - 18	905*		△	△	△		906		△	△	△		
	200 Phoenix		05 - 09	544*	△	△	△	△		546	△		△	△		
	200 Phoenix		10 - 14	905*		△	△	△		546	△		△	△		
	200 Sawtooth		06 - 07	544*	△	△	△	△		544	△	△	△	△		
	250 2x4, 4x4		90 - 93	716*	△	△	△	△		717	△	△	△	△		
	250 Big Boss 4x6, 6x6		89 - 93	716*	△	△	△	△		717	△	△	△	△		
	250 Big Boss 4x6, 6x6 Middle Axle Brake		89 - 93	717	△	△	△	△								
	250 Cyclone		87 - 87	2028*						643	△					
	250 Trail Blazer		90 - 98	716*	△	△	△	△		717	△	△	△	△		
	250 Trail Blazer		99 - 07	716*	△	△	△	△		755		△	△	△		

Applications  
ATV/UTV

\* = 2 sets required / 2 jeux pour l'Avant.

△ = Available quality / Qualité disponible.

To select compound for off-road front/rear - see page 21-23 / Pour sélectionner vos plaquettes off-road avant/arrière - voir page 21-23.

**COMPOUND CHOICE**5xx - 9xx = ATV/UTV Brake Pads  
2xxx = Brake Shoes**COMPOUND CHOICE**5xx - 9xx = ATV/UTV Brake Pads  
2xxx = Brake ShoesApplications  
ATV/UTV

<b>POLARIS</b>				<b>HF</b>	<b>ATS</b>	<b>SI</b>	<b>RSI</b>	<b>PSI</b>		<b>HF</b>	<b>ATS</b>	<b>SI</b>	<b>RSI</b>	<b>PSI</b>
250 Trail Boss	88 - 90	642*	Δ	Δ	Δ	Δ	Δ	Δ	643	Δ				
250 Trail Boss	91 - 99	716*	Δ	Δ	Δ	Δ	Δ		717	Δ	Δ	Δ	Δ	
250 Trail Boss 2x4, 4x4	91 - 92	716*	Δ	Δ	Δ	Δ	Δ		717	Δ	Δ	Δ	Δ	
250 Xplorer 4x4	00 - 02	716*	Δ	Δ	Δ	Δ	Δ		755		Δ	Δ	Δ	
300 2x4, 4x4	94 - 95	716*	Δ	Δ	Δ	Δ	Δ		717	Δ	Δ	Δ	Δ	
300 Big Boss 6x6	94 - 94	716*	Δ	Δ	Δ	Δ	Δ		717	Δ	Δ	Δ	Δ	
300 Big Boss 6x6 Middle Axle Brake	94 - 94	717	Δ	Δ	Δ	Δ	Δ							
300 Hawkeye 2x4, 4x4	06 - 06	822*		Δ	Δ	Δ	Δ	Δ	822		Δ	Δ	Δ	Δ
300 Hawkeye 2x4, 4x4	07 - 11	716*	Δ	Δ	Δ	Δ	Δ		716	Δ	Δ	Δ	Δ	
300 Sportsman 4x4	08 - 11	642*	Δ	Δ	Δ	Δ	Δ	Δ	642	Δ	Δ	Δ	Δ	Δ
300 Xplorer 4x4	96 - 99	716*	Δ	Δ	Δ	Δ	Δ		717	Δ	Δ	Δ	Δ	
300 Xpress 2x4	98 - 99	716*	Δ	Δ	Δ	Δ	Δ		717	Δ	Δ	Δ	Δ	
300 Xpress L	96 - 97	716*	Δ	Δ	Δ	Δ	Δ		717	Δ	Δ	Δ	Δ	
325 Magnum 2x4, 4x4	00 - 02	716*	Δ	Δ	Δ	Δ	Δ		755		Δ	Δ	Δ	
325 Trail Boss	00 - 02	716*	Δ	Δ	Δ	Δ	Δ		755		Δ	Δ	Δ	
325 Xpedition	00 - 01	642*	Δ	Δ	Δ	Δ	Δ	Δ	755		Δ	Δ	Δ	
325 Xpedition	02 - 02	642*	Δ	Δ	Δ	Δ	Δ	Δ	787		Δ	Δ	Δ	
330 ATP	04 - 05	716*	Δ	Δ	Δ	Δ	Δ		716	Δ	Δ	Δ	Δ	
330 ATP	06 - 05	716*	Δ	Δ	Δ	Δ	Δ		787		Δ	Δ	Δ	
330 E Trail Blazer	08 - 12	642*	Δ	Δ	Δ	Δ	Δ	Δ	787		Δ	Δ	Δ	
330 Magnum 2x4, 4x4	03 - 13	716*	Δ	Δ	Δ	Δ	Δ		787		Δ	Δ	Δ	
330 Trail Boss	03 - 14	716*	Δ	Δ	Δ	Δ	Δ		755		Δ	Δ	Δ	
335 Sportsman 4x4	99 - 02	716*	Δ	Δ	Δ	Δ	Δ		755		Δ	Δ	Δ	
350 Big Boss	93 - 93	716*	Δ	Δ	Δ	Δ	Δ		717	Δ	Δ	Δ	Δ	
350 Big Boss Middle Axle Brake	93 - 93	717	Δ	Δ	Δ	Δ	Δ							
350 L 2x4, 4x4	90 - 90	716*	Δ	Δ	Δ	Δ	Δ		717	Δ	Δ	Δ	Δ	
350 L 4x4	93 - 93	716*	Δ	Δ	Δ	Δ	Δ		717	Δ	Δ	Δ	Δ	
350 Sportsman 4x4	93 - 93	716*	Δ	Δ	Δ	Δ	Δ		717	Δ	Δ	Δ	Δ	
0 350 Trail Boss 2x4	85 - 87	2028*												
350 Trail Boss 2x4, 4x4	88 - 89	716*	Δ	Δ	Δ	Δ	Δ		717	Δ	Δ	Δ	Δ	
350 Trail Boss L 2x4	91 - 93	716*	Δ	Δ	Δ	Δ	Δ		717	Δ	Δ	Δ	Δ	
350 Trail Boss L 4x4	91 - 91	716*	Δ	Δ	Δ	Δ	Δ		717	Δ	Δ	Δ	Δ	
400 Big Boss L 6x6	96 - 96	716*	Δ	Δ	Δ	Δ	Δ		717	Δ	Δ	Δ	Δ	
400 Big Boss L 6x6 Middle Axle Brake	96 - 96	756		Δ	Δ	Δ	Δ							
400 L 2x4	94 - 95	716*	Δ	Δ	Δ	Δ	Δ		717	Δ	Δ	Δ	Δ	
400 L 4x4	94 - 94	716*	Δ	Δ	Δ	Δ	Δ		717	Δ	Δ	Δ	Δ	
400 Scrambler 2x4, 4x4	00 - 03	716*	Δ	Δ	Δ	Δ	Δ		755		Δ	Δ	Δ	
400 Scrambler 4x4	98 - 98	716*	Δ	Δ	Δ	Δ	Δ		717	Δ	Δ	Δ	Δ	
400 Scrambler 4x4	99 - 03	716*	Δ	Δ	Δ	Δ	Δ		755		Δ	Δ	Δ	
400 Scrambler L 4x4	95 - 97	716*	Δ	Δ	Δ	Δ	Δ		717	Δ	Δ	Δ	Δ	
400 Sport	99 - 00	716*	Δ	Δ	Δ	Δ	Δ		755		Δ	Δ	Δ	
400 Sport L	94 - 98	716*	Δ	Δ	Δ	Δ	Δ		717	Δ	Δ	Δ	Δ	
400 Sportsman	01 - 13	716*	Δ	Δ	Δ	Δ	Δ		755		Δ	Δ	Δ	
400 Sportsman L 4x4	94 - 97	716*	Δ	Δ	Δ	Δ	Δ		717	Δ	Δ	Δ	Δ	
400 Trail Blazer	03 - 04	716*	Δ	Δ	Δ	Δ	Δ		755		Δ	Δ	Δ	
400 Xplorer L 4x4	95 - 99	716*	Δ	Δ	Δ	Δ	Δ		717	Δ	Δ	Δ	Δ	
400 Xplorer L 4x4	00 - 02	716*	Δ	Δ	Δ	Δ	Δ		755		Δ	Δ	Δ	
400 Xpress L	96 - 97	716*	Δ	Δ	Δ	Δ	Δ		717	Δ	Δ	Δ	Δ	
425 2x4, 4x4 Magnum	95 - 98	716*	Δ	Δ	Δ	Δ	Δ		717	Δ	Δ	Δ	Δ	
425 Magnum 6x6	96 - 96	716*	Δ	Δ	Δ	Δ	Δ		717	Δ	Δ	Δ	Δ	
425 Magnum 6x6 Middle Axle Brake	96 - 96	756		Δ	Δ	Δ	Δ							
425 Xpedition 4x4	00 - 03	716*	Δ	Δ	Δ	Δ	Δ		755		Δ	Δ	Δ	
450 Outlaw MXR	09 - 11	898*		Δ	Δ	Δ	Δ	Δ	642	Δ	Δ	Δ	Δ	Δ
450 Outlaw S	08 - 08	898*		Δ	Δ	Δ	Δ	Δ	642	Δ	Δ	Δ	Δ	Δ
450 Sportsman	06 - 09	716*	Δ	Δ	Δ	Δ	Δ		787		Δ	Δ	Δ	
455 Diesel EBS 4x4	99 - 01	716*	Δ	Δ	Δ	Δ	Δ		755		Δ	Δ	Δ	
500 ATP HO	04 - 05	716*	Δ	Δ	Δ	Δ	Δ		716	Δ	Δ	Δ	Δ	
500 Big Boss 6x6	98 - 99	716*	Δ	Δ	Δ	Δ	Δ		717	Δ	Δ	Δ	Δ	
500 Big Boss 6x6 Middle Axle Brake	98 - 99	717	Δ	Δ	Δ	Δ	Δ							
500 E Scrambler 2x4, 4x4	08 - 11	642*	Δ	Δ	Δ	Δ	Δ	Δ	787		Δ	Δ	Δ	
500 Magnum 2x4, 4x4	02 - 07	716*	Δ	Δ	Δ	Δ	Δ		787		Δ	Δ	Δ	
500 Magnum 4x4	00 - 01	716*	Δ	Δ	Δ	Δ	Δ		755		Δ	Δ	Δ	
500 Outlaw	06 - 09	716*	Δ	Δ	Δ	Δ	Δ		716	Δ	Δ	Δ	Δ	
500 Predator	03 - 13	716*	Δ	Δ	Δ	Δ	Δ		716	Δ	Δ	Δ	Δ	
500 Predator e	06 - 13	716*	Δ	Δ	Δ	Δ	Δ		787		Δ	Δ	Δ	
500 Ranger 2x4	08 - 07	897*		Δ	Δ	Δ	Δ	Δ	800		Δ	Δ	Δ	
500 Ranger 2x4 EFI	08 - 13	897*		Δ	Δ	Δ	Δ	Δ	800		Δ	Δ	Δ	
500 Ranger 2x4, 4x4, 6x6	02 - 13	800*		Δ	Δ	Δ	Δ	Δ	800		Δ	Δ	Δ	

\* = 2 sets required / 2 jeux pour l'Avant.

Δ = Available quality / Qualité disponible.

To select compound for off-road front/rear - see page 21-23 / Pour sélectionner vos plaquettes off-road avant/arrière - voir page 21-23.



**COMPOUND CHOICE**

5xx - 9xx = ATV/UTV Brake Pads  
2xxx = Brake Shoes



**COMPOUND CHOICE**

5xx - 9xx = ATV/UTV Brake Pads  
2xxx = Brake Shoes

POLARIS			HF	ATS	SI	RSI	PSI	HF	ATS	SI	RSI	PSI
500 Ranger 4x4	12 - 13	897*		△	△	△	△	800		△	△	△
500 Ranger 6x6	00 - 02	716*	△	△	△	△						
500 Ranger XP	06 - 09	800*		△	△	△		800		△	△	△
500 Revolver	06 - 06	642*	△	△	△	△	△	642	△	△	△	△
500 Scrambler 2x4	01 - 02	716*	△	△	△	△		755		△	△	△
500 Scrambler 4x4	97 - 97	716*	△	△	△	△		717	△	△	△	△
500 Scrambler 4x4	98 - 13	716*	△	△	△	△		755		△	△	△
500 Sportsman 4x4	96 - 14	716*	△	△	△	△		717	△	△	△	△
500 Sportsman 6x6	00 - 11	716*	△	△	△	△		757		△	△	△
500 Sportsman EBS 4x4	98 - 02	716*	△	△	△	△		755		△	△	△
500 Sportsman HO (from 16.12.2008)	09 - 14	642*	△	△	△	△	△	899		△	△	△
500 Sportsman HO (to 15.12.2008)	03 - 08	642*	△	△	△	△	△	787		△	△	△
500 Xplorer 4x4	97 - 97	716*	△	△	△	△		717	△	△	△	△
525 Outlaw	07 - 13	898*		△	△	△	△	642	△	△	△	△
525 Outlaw IRS	08 - 13	898*		△	△	△	△	642	△	△	△	△
525 Outlaw S	08 - 11	898*		△	△	△	△	642	△	△	△	△
550 Sportsman	11 - 14	899*		△	△	△		899		△	△	△
550 Sportsman EPS	10 - 14	899*		△	△	△		899		△	△	△
550 Sportsman EPS X2	14 - 14	899*		△	△	△		899		△	△	△
550 Sportsman Touring EPS	10 - 12	899*		△	△	△		899		△	△	△
550 Sportsman X2	10 - 14	899*		△	△	△		899		△	△	△
550 Sportsman XP	09 - 12	899*		△	△	△		899		△	△	△
550 Sportsman XP EPS	09 - 14	899*		△	△	△		899		△	△	△
550 Sportsman XP Touring EPS	12 - 14	899*		△	△	△		899		△	△	△
570 Ranger RZR EFI	12 - 13	898*		△	△	△	△	642	△	△	△	△
600 Sportsman	03 - 06	642*	△	△	△	△	△	787		△	△	△
700 MVR5 4x4	08 - 08	897*		△	△	△	△	897		△	△	△
700 Ranger 4x4 EFI	08 - 08	897*		△	△	△	△	800		△	△	△
700 Ranger 6x6 EFI	12 - 13	897*		△	△	△	△	800		△	△	△
700 Sportsman	02 - 09	642*	△	△	△	△	△	787		△	△	△
700 Sportsman MV 700	05 - 06	642*	△	△	△	△	△	787		△	△	△
800 MVR5 4x4	08 - 08	897*		△	△	△	△	897		△	△	△
800 Ranger 4x4 EFI	10 - 10	897*		△	△	△	△	897		△	△	△
800 Ranger 6x6 EFI	12 - 15	897*		△	△	△	△	897		△	△	△
800 Ranger Crew	12 - 15	897*		△	△	△	△	897		△	△	△
800 Ranger RZR EFI	08 - 14	898*		△	△	△	△	642	△	△	△	△
800 Ranger RZR S EFI	09 - 15	898*		△	△	△	△	642	△	△	△	△
800 Ranger RZR4 EFI	12 - 14	897*		△	△	△	△	800		△	△	△
800 Ranger XP	12 - 13	897*		△	△	△	△	800		△	△	△
800 RZR	08 - 15	898*		△	△	△	△	642	△	△	△	△
800 RZR-4	10 - 14	897*		△	△	△	△	800		△	△	△
800 Sportsman (from 16.12.2008)	09 - 14	642*	△	△	△	△	△	899		△	△	△
800 Sportsman (to 15.12.2008)	05 - 08	642*	△	△	△	△	△	787		△	△	△
850 Forest	15 - 15	899*		△	△	△	△	899		△	△	△
850 Scrambler	15 - 15	899*		△	△	△	△	899		△	△	△
850 Scrambler HO EPS	13 - 15	899*		△	△	△	△	899		△	△	△
850 Scrambler MD	15 - 15	899*		△	△	△	△	899		△	△	△
850 Scrambler XP HO EPS	14 - 15	899*		△	△	△	△	899		△	△	△
850 Sportsman	11 - 13	899*		△	△	△	△	899		△	△	△
850 Sportsman MV	12 - 12	899*		△	△	△	△	899		△	△	△
850 Sportsman Touring	14 - 15	899*		△	△	△	△	899		△	△	△
850 Sportsman Touring EPS	10 - 13	899*		△	△	△	△	899		△	△	△
850 Sportsman Touring HO EPS	13 - 14	899*		△	△	△	△	899		△	△	△
850 Sportsman Touring MD	15 - 15	899*		△	△	△	△	899		△	△	△
850 Sportsman X2	11 - 11	899*		△	△	△	△	899		△	△	△
850 Sportsman XP	09 - 14	899*		△	△	△	△	899		△	△	△
850 Sportsman XP EPS	09 - 14	899*		△	△	△	△	899		△	△	△
850 Sportsman XP HO EPS	13 - 14	899*		△	△	△	△	899		△	△	△
850 Sportsman XP HO EPS MD	15 - 15	899*		△	△	△	△	899		△	△	△
850 Sportsman XP Touring EPS	15 - 15	899*		△	△	△	△	899		△	△	△
900 Ranger 4x4 Diesel	10 - 14	897*		△	△	△	△	897		△	△	△
900 Ranger RZR4 XP EFI	12 - 15	897*		△	△	△	△	897		△	△	△
900 Ranger RZR4 XP4 EFI	12 - 14	897*		△	△	△	△	897		△	△	△
RZR 900 50/55/60 Inch	15 - 20	970*		△	△	△	△	898		△	△	△
RZR-S 900 60 Inch	20 - 20	970*		△	△	△	△	898		△	△	△
925 RZR XP Turbo	16 - 19	954*		△	△			897		△	△	△
925 RZR XP Turbo	20 - 20	954*		△	△			978		△	△	△
925 RZR XP4 Turbo	16 - 19	954*		△	△			897		△	△	△

Applications  
ATV/UTV

\* = 2 sets required / 2 jeux pour l'Avant.

△ = Available quality / Qualité disponible.

To select compound for off-road front/rear - see page 21-23 / Pour sélectionner vos plaquettes off-road avant/arrière - voir page 21-23.

**COMPOUND CHOICE**5xx - 9xx = ATV/UTV Brake Pads  
2xxx = Brake Shoes**COMPOUND CHOICE**5xx - 9xx = ATV/UTV Brake Pads  
2xxx = Brake Shoes

POLARIS				HF	ATS	SI	RSI	PSI		HF	ATS	SI	RSI	PSI
925	RZR XP4 Turbo	20 - 20	954*			△	△		978			△	△	△
925	RZR XP4 Turbo S	19 - 20	977*			△	△		897		△	△	△	△
925	RZR XP4 Turbo S Velocity	19 - 20	977*			△	△		897		△	△	△	△
1000	Forest	15 - 15	899*		△	△	△		899		△	△	△	
1000	General EPS	16 - 18	897*		△	△	△	△	898		△	△	△	△
1000	Ranger RZR XP	14 - 14	897*		△	△	△	△	897		△	△	△	△
1000	Scrambler MD	15 - 18	899*		△	△	△		899		△	△	△	
1000	Scrambler XP	15 - 18	899*		△	△	△		899		△	△	△	
1000	Scrambler XP HO EPS	14 - 14	899*		△	△	△		899		△	△	△	
1000	Sportsman MD	15 - 18	899*		△	△	△		899		△	△	△	
1000	Sportsman Touring	15 - 18	899*		△	△	△		899		△	△	△	
1000	Sportsman XP	15 - 18	899*		△	△	△		899		△	△	△	
RZR	1000 60 Inch	16 - 20	970*			△	△	△	898		△	△	△	△
RZR-S	1000 60 Inch	20 - 20	970*			△	△	△	898		△	△	△	△
1050	MV Diesel Crew	13 - 18	897*		△	△	△	△	897		△	△	△	△
<b>SUZUKI</b>														
ALT	50	83 - 84							2020					
LT	50	84 - 02							2020					
LT-A	50 Quadmaster	01 - 05	2101						2017					
LT-Z	50 Quadsport	06 - 20	2101*						2017					
LT	80	87 - 06	2101*						2104					
LT-Z	90 Quadsport	07 - 20	2017*						2104					
ALT	125	84 - 86							2016					
ALT	125 D	83 - 83							2107					
LT	125 D	83 - 83							2107					
LT	125 E-H	84 - 87							2016					
LT	160	89 - 92	2181*						2016					
LT-F	160	91 - 04	2181*						2016					
ALT	185	85 - 87							2016					
LT	185	84 - 87							2016					
LT	230	85 - 86	2051*						2016					
LT	230	85 - 88	591*	△		△	△		584	△		△	△	
LT	230	86 - 93	591*	△		△	△		592	△		△	△	
LT-F	230	86 - 87	2051*						2016					
LT	250	85 - 86	2051*						2098					
LT	250	85 - 87	591*	△		△	△		584	△		△	△	
LT	250	88 - 94	591*	△		△	△		649	△		△	△	
LT	250	89 - 90	591*	△		△	△		592	△		△	△	
LT	250 4WD	87 - 98	2053*						2110					
LT-F	250	88 - 01	2053*						2110					
LT-F	250 4WD V, W Quadrunner	97 - 98	2053*						2098					
LT-F	250 Ozark	03 - 13	536*	△		△	△							
LT-Z	250 Quad Sport	04 - 11	536*	△		△	△							
LT-F	280 4WD	91 - 98							2052					
LT	300	87 - 89	2051*						2098					
LT-F	300	88 - 90	2051						2052					
LT-F	300 King Quad	91 - 02							2052					
LT-F	300 King Quad Left	02 - 02	611	△		△	△	△						
LT-F	300 King Quad Right	02 - 02	638	△		△	△	△						
KLT-A	400 King Quad Left	08 - 14	835			△	△							
KLT-A	400 King Quad Right	08 - 14	836			△	△							
KLT-F	400 King Quad Left	08 - 14	835			△	△							
KLT-F	400 King Quad Right	08 - 14	836			△	△							
LT-A	400 Eiger 2WD/4WD	02 - 07	536*	△		△	△		2018					
LT-A	400 King Quad Left	08 - 14	835			△	△							
LT-A	400 King Quad Right	08 - 14	836			△	△							
LT-F	400 Eiger 2WD/4WD	02 - 07	536*	△		△	△		2018					
LT-F	400 King Quad Left	08 - 14	835			△	△							
LT-F	400 King Quad Right	08 - 14	836			△	△							
LT-Z	400 Quad Sport	02 - 19	592*	△		△	△		649	△		△	△	
LT-A	450 King Quad Left	08 - 14	835			△	△							
LT-A	450 King Quad Right	08 - 14	836			△	△							
LT-R	450 Left	06 - 12	611	△		△	△	△	649	△		△	△	
LT-R	450 Right	06 - 12	638	△		△	△	△						
LT	500	87 - 95	591*	△		△	△		649	△		△	△	
LT-A	500 F Vinson	02 - 02	536*	△		△	△							
LT-A	500 FY Quadmaster Left	00 - 08	611	△		△	△	△						

\* = 2 sets required / 2 jeux pour l'Avant.

△ = Available quality / Qualité disponible.

To select compound for off-road front/rear - see page 21-23 / Pour sélectionner vos plaquettes off-road avant/arrière - voir page 21-23.

**COMPOUND CHOICE**5xx - 9xx = ATV/UTV Brake Pads  
2xxx = Brake Shoes**COMPOUND CHOICE**5xx - 9xx = ATV/UTV Brake Pads  
2xxx = Brake Shoes

SUZUKI					HF	ATS	SI	RSI	PSI		HF	ATS	SI	RSI	PSI	
LT-A	500	FY Quadmaster Right	00 - 08	638	△		△	△	△							
LT-A	500	King Quad Left	11 - 14	835			△	△								
LT-A	500	King Quad Right	11 - 14	836			△	△								
LT-F	500	F Left	98 - 07	638	△		△	△	△							
LT-F	500	F Right	98 - 07	611	△		△	△	△							
LT-A	700	King Quad Left	05 - 11	835			△	△								
LT-A	700	King Quad Right	05 - 11	836			△	△								
LT-V	700	Quadrunner Twin Peaks Left	04 - 06	801			△	△								
LT-V	700	Quadrunner Twin Peaks Right	04 - 06	798			△	△								
LT-A	750	King Quad Left	08 - 14	835			△	△								
LT-A	750	King Quad Right	08 - 14	836			△	△								
<b>SYM</b>																
	200	Quadlander	12 - 13	810*	△		△	△		847	△		△	△		
	200	Trackrunner	05 - 08	810*	△		△	△		847	△		△	△		
	250	Quadlander	06 - 07	810*	△		△	△		847	△		△	△		
	300	City Max	06 - 07	810*	△		△	△		847	△		△	△		
	300	Quadlander	06 - 13	810*	△		△	△		810	△		△	△		
	600	Quad Raider	08 - 15	810*	△		△	△		810	△		△	△		
<b>TGB</b>																
	50	Buffalo	03 - 03							688	△					
<b>YAMAHA</b>																
YFM	50	Raptor	04 - 11	2028*						2034						
YF	60	S Moto 4	86 - 86							2050						
YT	60	Tri Zinger	84 - 85							2050						
YFM	80		87 - 88	2050*						2034						
YFM	80		92 - 94	2028*						2034						
YFM	80	Badger	95 - 07	2028*						2034						
YFM	80	Grizzly	05 - 08	2028*						2034						
YFM	80	N, S Moto 4	85 - 86							2034						
YFM	80	Raptor	02 - 08	2028*						2034						
YFM	90	RY Raptor	09 - 15	2028*						586	△		△	△		
YFM	100	Champ	87 - 88	2050*						2034						
YFM	100	Champ	89 - 91	2028*						2034						
YFA	125	1 D, E Breeze	92 - 93	2028*						2034						
YFA	125	1 F Breeze	94 - 94	2028*						2034						
YFA	125	1 G-M Breeze	95 - 07	2028*						2034						
YFA	125	1 W, A, B Breeze	89 - 91	2028*						2034						
YFM	125	Grizzly	04 - 13	2028*						2034						
YT	125	Tri Moto	80 - 81							617	△					
YT	125	Tri Moto	82 - 85							576	△			△	△	
YT	175	Tri Moto	82 - 83	2028						576	△			△	△	
YFM	200	DXS-DXW Moto 4	86 - 87	2028*						576	△			△	△	
YFM	200	N Moto 4	85 - 89	2028*						576	△			△	△	
YFS	200	R Blaster	03 - 06	536*	△		△	△		592	△			△	△	
YFS	200	U-P Blaster	88 - 02	2028						637	△			△	△	
YTM	200	EK, EL Tri Moto	83 - 84	2028						576	△			△	△	
YTM	200	ERN Tri Moto	85 - 85	2028						576	△			△	△	
YTM	200	K-N Tri Moto	83 - 85	2028						576	△			△	△	
YFM	225	Moto 4	86 - 88	2028*						576	△			△	△	
YTM	225	DRN, DRS Tri Moto	85 - 86	2028						576	△			△	△	
YTM	225	DXK, DXN Tri Moto	83 - 85	2028						576	△			△	△	
YFB	250	Timberwolf	92 - 94	2028*						2035						
YFB	250	Timberwolf	95 - 96	2035*						2035						
YFB	250	Timberwolf 4WD	94 - 03	2035*						2035						
YFM	250		89 - 91	2035*						576	△			△	△	
YFM	250	AN Bruin 2x4	05 - 07	536*	△		△	△								
YFM	250	Bear Tracker	01 - 04	536*	△		△	△								
YFM	250	Raptor Left	09 - 14	850			△	△		592	△			△	△	
YFM	250	Raptor Right	09 - 14	849			△	△								
YFM	250	Timberwolf (YFB 250 G)	95 - 95	2035*						2035						
YFU1TW	250	Pro Hauler	89 - 89	2035*						2177						
YFU1W	250	Pro Hauler	89 - 90	2035*						2177						
YTZ	250	Tri Moto	85 - 86	575	△		△	△		575	△			△	△	
YFM	300	Grizzly	12 - 13	544*	△		△	△		586	△			△	△	
YFM	300	Warrior	89 - 89	536	△		△	△		584	△			△	△	

Applications  
ATV/UTV

\* = 2 sets required / 2 jeux pour l'Avant.  
 △ = Available quality / Qualité disponible.

**COMPOUND CHOICE**5xx - 9xx = ATV/UTV Brake Pads  
2xxx = Brake Shoes**COMPOUND CHOICE**5xx - 9xx = ATV/UTV Brake Pads  
2xxx = Brake ShoesApplications  
ATV/UTV

YAMAHA				HF	ATS	SI	RSI	PSI		HF	ATS	SI	RSI	PSI
YFM	350	Big Bear Special Edition	99 - 99	2178*					2066					
YFM	350	Bruin 2x4, 4x4	04 - 07	536*	△	△	△							
YFM	350	ERT, ERU	87 - 88	2028*					576	△		△	△	
YFM	350	ERW, ERA-G	89 - 95	2035*					576	△		△	△	
YFM	350	FWB L, LC Big Bear	99 - 99	536*	△		△		2066					
YFM	350	FWH, FWJ, FWK Big Bear	96 - 98	2178*					2066					
YFM	350	FWT, FWU Big Bear	87 - 88	2114*					576	△		△	△	
YFM	350	FWW, FWA-G Big Bear	89 - 95	2178*					576	△		△	△	
YFM	350	FXG-FXM Wolverine	95 - 11	536*	△		△	△	592	△		△	△	
YFM	350	R Raptor	04 - 14	592*	△		△	△	592	△		△	△	
YFM	350	UH, UJ, UK	96 - 98	2178*					2066					
YFM	350	XG,XH Warrior	95 - 96	536*	△		△	△	592	△		△	△	
YFM	350	XT, XU Warrior	87 - 88	575*	△		△	△	592	△		△	△	
YFM	350	XW, XA-M Warrior	89 - 07	536*	△		△	△	536	△		△	△	
YFP	350	U Terrapro	88 - 88	2035*					2177					
YFZ	350	Banshee	87 - 89	575*	△		△	△	592	△		△	△	
YFZ	350	Banshee	90 - 06	536*	△		△	△	592	△		△	△	
YFM	400	FAM Kodiak	00 - 02	536*	△		△	△	754	△		△	△	△
YFM	400	FAR Kodiak Automatic	03 - 03	536*	△		△	△	2066					
YFM	400	FWN Big Bear 4WD	00 - 11	536*	△		△	△	754	△		△	△	△
YFM	400	FWNH Big Bear-Buckmaster 4WD	00 - 11	536*	△		△	△	754	△		△	△	△
YFM	400	Kodiak	93 - 99	2178*					2066					
YFM	400	N Big Bear 2WD	00 - 11	536*	△		△	△	754	△		△	△	△
YFM	450	FA Kodiak	03 - 07	536*	△		△	△	754	△		△	△	△
YFM	450	Wolverine	06 - 10	536*	△		△	△	754	△		△	△	△
YFZ	450	S Left	04 - 05	638	△		△	△	592	△		△	△	
YFZ	450	S Right	04 - 05	611	△		△	△	592	△		△	△	
YFZ	450	S Left	06 - 09	638	△		△	△	709	△		△	△	
YFZ	450	S Right	06 - 09	611	△		△	△						
YXR	450	Rhino Left	06 - 09	611	△		△	△	816			△	△	
YXR	450	Rhino Right	06 - 09	638	△		△	△						
YFM	550	FGPW Grizzly Left	09 - 16	850			△	△	852			△	△	
YFM	550	FGPW Grizzly Right	09 - 16	849			△	△	851			△	△	
YFM	600	4x4 Grizzly	98 - 01	592*	△		△	△	2066					
	660	Rhino Left	05 - 08	611	△		△	△	816			△	△	
	660	Rhino Right	05 - 08	638	△		△	△						
YFM	660	FWAP 4x4 Grizzly	02 - 08	592*	△		△	△	799			△	△	
YFM	660	RN Raptor	01 - 09	592*	△		△	△	592	△		△	△	
YFM	700	FGPW Grizzly Left	07 - 17	850			△	△	852			△	△	
YFM	700	FGPW Grizzly Right	07 - 17	849			△	△	851			△	△	
YFM	700	R Raptor Left	06 - 08	611	△		△	△	816			△	△	
YFM	700	R Raptor Right	06 - 08	638	△		△	△						
YFM	700	Raptor Left	09 - 12	611	△		△	△	816			△	△	
YFM	700	Raptor Right	09 - 12	638	△		△	△						
YFM	700	Raptor Left	13 - 14	611	△		△	△	709	△		△	△	
YFM	700	Raptor Right	13 - 14	638	△		△	△						
YXC	700	Viking VI Left	15 - 16	971			△	△	973			△	△	△
YXC	700	Viking VI Right	15 - 16	972			△	△	974			△	△	△
YXC	700	Viking VI EPS Left	15 - 21	971			△	△	973			△	△	△
YXC	700	Viking VI EPS Right	15 - 21	972			△	△	974			△	△	△
YXC	700	Viking VI EPS Special Edition Left	16 - 17	971			△	△	973			△	△	△
YXC	700	Viking VI EPS Special Edition Right	16 - 17	972			△	△	974			△	△	△
YXE	700	Wolverine Left	16 - 18	971			△	△	973			△	△	△
YXE	700	Wolverine Right	16 - 18	972			△	△	974			△	△	△
YXE	700	Wolverine EPS Left	17 - 17	971			△	△	973			△	△	△
YXE	700	Wolverine EPS Right	17 - 17	972			△	△	974			△	△	△
YXE	700	Wolverine R-Spec Left	16 - 16	971			△	△	973			△	△	△
YXE	700	Wolverine R-Spec Right	16 - 16	972			△	△	974			△	△	△
YXE	700	Wolverine R-Spec EPS Left	16 - 18	971			△	△	973			△	△	△
YXE	700	Wolverine R-Spec EPS Right	16 - 18	972			△	△	974			△	△	△
YXE	700	Wolverine R-Spec EPS SE Left	16 - 16	971			△	△	973			△	△	△
YXE	700	Wolverine R-Spec EPS SE Right	16 - 16	972			△	△	974			△	△	△
YXE	700	Wolverine R-Spec EPS Special Edition Left	17 - 17	971			△	△	973			△	△	△
YXE	700	Wolverine R-Spec EPS Special Edition Right	17 - 17	972			△	△	974			△	△	△

\* = 2 sets required / 2 jeux pour l'Avant.

△ = Available quality / Qualité disponible.

To select compound for off-road front/rear - see page 21-23 / Pour sélectionner vos plaquettes off-road avant/arrière - voir page 21-23.

**COMPOUND CHOICE**5xx - 9xx = ATV/UTV Brake Pads  
2xxx = Brake Shoes**COMPOUND CHOICE**5xx - 9xx = ATV/UTV Brake Pads  
2xxx = Brake Shoes

YAMAHA					HF	ATS	SI	RSI	PSI		HF	ATS	SI	RSI	PSI
YXM	700	Viking Left	14 - 20	971			△	△	△	973			△	△	△
YXM	700	Viking Right	14 - 20	972			△	△	△	974			△	△	△
YXM	700	Viking EPS Left	14 - 21	971			△	△	△	973			△	△	△
YXM	700	Viking EPS Right	14 - 21	972			△	△	△	974			△	△	△
YXM	700	Viking EPS SE Left	14 - 17	971			△	△	△	973			△	△	△
YXM	700	Viking EPS SE Right	14 - 17	972			△	△	△	974			△	△	△
YXM	700	Viking EPS Special E Left	19 - 19	971			△	△	△	973			△	△	△
YXM	700	Viking EPS Special E Right	19 - 19	972			△	△	△	974			△	△	△
YXM	700	Viking EPS Special Edition Left	16 - 16	971			△	△	△	973			△	△	△
YXM	700	Viking EPS Special Edition Right	16 - 16	972			△	△	△	974			△	△	△
YXR	700	Rhino Left	08 - 14	638	△		△	△	△	638	△		△	△	△
YXR	700	Rhino Right	08 - 14	611	△		△	△	△	611	△		△	△	△
YXE	850	Wolverine X2 Left	19 - 19	971			△	△	△	973			△	△	△
YXE	850	Wolverine X2 Right	19 - 19	972			△	△	△	974			△	△	△
YXE	850	Wolverine X2 EPS Left	20 - 20	971			△	△	△	973			△	△	△
YXE	850	Wolverine X2 EPS Right	20 - 20	972			△	△	△	974			△	△	△
YXE	850	Wolverine X2 R-Spec Left	19 - 20	971			△	△	△	973			△	△	△
YXE	850	Wolverine X2 R-Spec Right	19 - 20	972			△	△	△	974			△	△	△
YXE	850	Wolverine X2 XTR Left	20 - 20	971			△	△	△	973			△	△	△
YXE	850	Wolverine X2 XTR Right	20 - 20	972			△	△	△	974			△	△	△
YXF	850	Wolverine X4 Left	18 - 20	971			△	△	△	973			△	△	△
YXF	850	Wolverine X4 Right	18 - 20	972			△	△	△	974			△	△	△
YXF	850	Wolverine X4 SE Left	19 - 19	971			△	△	△	973			△	△	△
YXF	850	Wolverine X4 SE Right	19 - 19	972			△	△	△	974			△	△	△
YXF	850	Wolverine X4 Special Left	19 - 19	971			△	△	△	973			△	△	△
YXF	850	Wolverine X4 Special Right	19 - 19	972			△	△	△	974			△	△	△
YXF	850	Wolverine X4 Special Edition Left	18 - 18	971			△	△	△	973			△	△	△
YXF	850	Wolverine X4 Special Edition Right	18 - 18	972			△	△	△	974			△	△	△
YXF	850	Wolverine X4 XTR Left	20 - 20	971			△	△	△	973			△	△	△
YXF	850	Wolverine X4 XTR Right	20 - 20	972			△	△	△	974			△	△	△
	1000	Wolverine RMAX 4	21 - 21	979*			△	△	△	980			△	△	△
	1000	Wolverine RMAX 4 LE	21 - 21	979*			△	△	△	980			△	△	△
	1000	Wolverine RMAX 4 SE	21 - 21	979*			△	△	△	980			△	△	△
YXE	1000		21 - 21	979*			△	△	△	980			△	△	△
YXZ	1000	EPS	16 - 20	979*			△	△	△	980			△	△	△
YXZ	1000	EPS SE	17 - 19	979*			△	△	△	980			△	△	△
YXZ	1000	EPS Special	20 - 20	979*			△	△	△	980			△	△	△
YXZ	1000	EPS Special Edition	16 - 17	979*			△	△	△	980			△	△	△
YXZ	1000	EPS SS	17 - 20	979*			△	△	△	980			△	△	△
YXZ	1000	SS Special	20 - 20	979*			△	△	△	980			△	△	△
YXZ	1000	SS XTR	20 - 20	979*			△	△	△	980			△	△	△

Applications  
ATV/UTV\* = 2 sets required / 2 jeux pour l'Avant.  
△ = Available quality / Qualité disponible.

# NEW! Get the brake feel you want!



Find the right brake pad compound for you and  
your bike with the new Compound Selector at  
[sbsbrakes.com](http://sbsbrakes.com)

Find the right compound for you and  
your bike

Click Start Now, answer 2-3 questions and get the answer right away

START NOW



@sbsbrakes | [sbsbrakes.com](http://sbsbrakes.com)

HI-TECH BRAKE SOLUTIONS  
MADE IN EUROPE





Allan Østli

Racing Manager SBS  
Winner Ducati Challenge

**sbs**<sup>®</sup>

GO AHEAD

**I KNOW  
WHAT YOU  
WANT!**

**ROAD RACING**



@sbsbrakes | sbsbrakes.com | #GoAhead

HI-TECH BRAKE SOLUTIONS  
MADE IN EUROPE



COMPOUND CHOICE



COMPOUND CHOICE



APRILIA				DS-1	DS-2	DC	RST		RQ	LS
RS	660	20 - 22	900*	△	△	△	△	730	△	△
RS	660 Trofeo	22 - 22	900*	△	△	△	△	730	△	△
RSV4	1000 , ABS	09 - 13	841*	△	△	△	△	730	△	△
RSV4-R	1000 , ABS APRC	10 - 10	841*	△	△	△	△	730	△	△
RSV4-RF	1000	15 - 20	901*	△	△	△	△	730	△	△
RSV4-RR	1000	15 - 20	901*	△	△	△	△	730	△	△
BIMOTA										
BB3	1000	14 - 18	901*	△	△	△	△	730	△	△
DB5	1000	05 - 11	762*	△		△	△	730	△	△
DB5	1000 S	07 - 11	762*	△		△	△	730	△	△
DB7	1098	08 - 08	762*	△		△	△	730	△	△
DB7	1099	09 - 09	901*	△	△	△	△	519	△	△
3D	1100 Tesi	07 - 11	762*	△		△	△	730	△	△
DB8	1198	10 - 14	901*	△	△	△	△	730	△	△
BMW										
M	1000 RR	21 - 22	985*	△	△	△	△	984	△	△
S	1000 RR	09 - 18	870*	△	△	△	△	675	△	△
S	1000 RR (Hayes cal.)	19 - 21	960*	△	△	△	△	675	△	△
S	1000 RR (Nissin cal.)	21 - 22	985*	△	△	△	△	675	△	△
S	1000 RR HP4	12 - 14	901*	△	△	△	△	675	△	△
	1200 HP2 Sport	08 - 10	901*	△	△	△	△	671	△	△
DUCATI										
	848	08 - 10	706*	△	△	△	△	730	△	△
	848 EVO	11 - 12	841*	△	△	△	△	730	△	△
	899 Panigale	14 - 15	900*	△	△	△	△	730	△	△
	955 Panigale V2	20 - 22	900*	△	△	△	△	730	△	△
	959 Panigale	16 - 20	900*	△	△	△	△	730	△	△
	959 Panigale Corse	18 - 20	900*	△	△	△	△	730	△	△
	996 S	01 - 01	706	△	△	△	△	519	△	△
	998 Panigale V4 R	19 - 21	841*	△	△	△	△	730	△	△
	998 Superleggera V4	20 - 21	841*	△	△	△	△	730	△	△
	1098 R	08 - 10	841*	△	△	△	△	730	△	△
	1098 R Bayliss LE	09 - 10	841*	△	△	△	△	730	△	△
	1100 Panigale V4	18 - 21	841*	△	△	△	△	730	△	△
	1100 Panigale V4 S	18 - 21	841*	△	△	△	△	730	△	△
	1100 Panigale V4 S Corse	19 - 19	841*	△	△	△	△	730	△	△
	1100 Panigale V4 SP	21 - 21	841*	△	△	△	△	730	△	△
	1100 Panigale V4 Speciale	18 - 19	841*	△	△	△	△	730	△	△
	1198	09 - 13	841*	△	△	△	△	730	△	△
	1198 S	09 - 12	841*	△	△	△	△	730	△	△
	1198 SP	11 - 12	841*	△	△	△	△	730	△	△
	1199 Panigale	12 - 14	841*	△	△	△	△	730	△	△
	1199 Panigale R	13 - 15	841*	△	△	△	△	730	△	△
	1199 Panigale S	12 - 14	841*	△	△	△	△	730	△	△
	1199 Superleggera	14 - 14	841*	△	△	△	△	730	△	△
	1299 Panigale	15 - 17	841*	△	△	△	△	730	△	△
	1299 Panigale R	15 - 17	841*	△	△	△	△	730	△	△
	1299 Panigale R Final Edition	17 - 20	841*	△	△	△	△	730	△	△
	1299 Panigale S	15 - 17	841*	△	△	△	△	730	△	△
	1299 Panigale S Anniversario	17 - 17	841*	△	△	△	△	730	△	△
	1299 Superleggera	17 - 17	841*	△	△	△	△	730	△	△
EBR										
	1190 RS	12 - 15	856	△			△	857		△
HARLEY DAVIDSON										
XR	1200	08 - 10	860*	△	△			808		△
HONDA										
CBR	250 R (Nissin cal)	11 - 13	627			△	△	881	△	△
CBR	250 RR	17 - 21	700	△	△	△	△	881	△	△
CBR	500 R	13 - 21	700	△	△	△	△	881	△	△
CBR	600 RR	18 - 21	947*	△	△	△	△	834	△	△
CBR	650 F	14 - 20	627*			△	△	881	△	△
CBR	650 F ABS	14 - 20	700*	△	△	△	△	881	△	△

\* = 2 sets required / 2 jeux pour l'Avant.

△ = Available quality / Qualité disponible.

To select compound for racing front/rear - see page 17-20 / Pour sélectionner vos plaquettes racing avant/arrière - voir page 17-20.



## COMPOUND CHOICE



## COMPOUND CHOICE



HONDA				DS-1	DS-2	DC	RST		RQ	LS	
CBR	1000	RR Fireblade	09 - 16	809*	△	△	△	△	834	△	△
CBR	1000	RR Fireblade	17 - 22	947*	△	△	△	△	834	△	△
CBR	1000	RR SP	14 - 22	901*	△	△	△	△	834	△	△
CBR	1000	RR SP2	17 - 19	901*	△	△	△	△	834	△	△
CBR	1000	RR-R Fireblade	20 - 22	985*	△	△	△	△	730	△	△
CBR	1000	RR-R SP Fireblade	20 - 21	901*	△	△	△	△	730	△	△
CBR	1000	RR-R SP Fireblade	22 - 22	841*	△	△	△	△	730	△	△
RC213V-S	1000		16 - 18	901*	△	△	△	△	730	△	△
<b>KAWASAKI</b>											
EX	250	R Ninja	18 - 20	955	△	△	△	△	638	△	△
ZX-25R	250		20 - 20	806	△	△	△	△	657	△	△
EX	300	R Ninja, ABS	13 - 17	638	△		△	△	638	△	△
EX	400	Ninja	18 - 22	955*	△	△	△	△	638	△	△
EX	400	Ninja KRT	18 - 18	638*	△		△	△	638	△	△
ZX-6R	600	Ninja	07 - 17	838*	△	△	△	△	687	△	△
ZX-6RR	600	Ninja	03 - 06	788*	△		△	△	687	△	△
ZX-6R	636	Ninja	13 - 18	894*			△	△	834	△	△
ZX-6R	636	Ninja KRT ABS	13 - 18	894*			△	△	834	△	△
ZX-6R	636	Ninja Upgrade DS	13 - 22	860*	△	△			834	△	△
ZX	1000	H2 Carbon Ninja	17 - 20	841*	△	△	△	△	730	△	△
ZX	1000	H2 Ninja	15 - 21	841*	△	△	△	△	730	△	△
ZX	1000	H2R Ninja	15 - 20	841*	△	△	△	△	730	△	△
ZX-10R	1000	Ninja	08 - 10	806*	△	△	△	△	687	△	△
ZX-10R	1000	Ninja	11 - 15	806*	△	△	△	△	834	△	△
ZX-10R	1000	Ninja	16 - 22	841*	△	△	△	△	834	△	△
ZX-10R	1000	Ninja ABS	12 - 15	806*	△	△	△	△	834	△	△
ZX-10R	1000	Ninja KRT	16 - 18	841*	△	△	△	△	834	△	△
ZX-10R	1000	Ninja SE	18 - 22	841*	△	△	△	△	834	△	△
ZX-10RR	1000	Ninja	17 - 22	841*	△	△	△	△	834	△	△
<b>KTM</b>											
RC	250		14 - 15	877			△	△	675	△	△
RC	250	Upgrade DS	14 - 15	634	△	△	△	△	675	△	△
RC	390		14 - 22	877			△	△	675	△	△
RC	390	Upgrade DS	14 - 22	634	△	△	△	△	675	△	△
	690	Duke R	14 - 17	841	△	△	△	△	675	△	△
RC8	890	C	22 - 22	841*	△	△	△	△	730	△	△
RC8	1190		08 - 11	841*	△	△	△	△	730	△	△
RC8	1190	R	09 - 15	841*	△	△	△	△	730	△	△
RC8	1190	R Track	11 - 15	841*	△	△	△	△	730	△	△
<b>MORIWAKI</b>											
MD	250		09 - 09	782			△	△	618	△	
<b>MV AGUSTA</b>											
F3	675		11 - 12	706*	△	△	△	△	763	△	△
F3	675		13 - 14	706*	△	△	△	△	730	△	△
F3	675		15 - 20	901*	△	△	△	△	730	△	△
F3	675	RC	16 - 20	901*	△	△	△	△	730	△	△
F3	800		14 - 20	901*	△	△	△	△	763	△	△
F3	800	RC	16 - 20	901*	△	△	△	△	730	△	△
F3	800	RR	21 - 22	841*	△	△	△	△	730	△	△
F4	1000	LH44	18 - 20	841*	△	△	△	△	763	△	△
F4	1000	R	12 - 19	841*	△	△	△	△	763	△	△
F4	1000	RC	15 - 20	841*	△	△	△	△	763	△	△
F4	1000	RR	12 - 20	841*	△	△	△	△	763	△	△
F4	1078	CC	08 - 11	841*	△	△	△	△	763	△	△
F4	1078	RR	08 - 11	841*	△	△	△	△	763	△	△
<b>OHVALE</b>											
GP-01	110		17 - 19	885				△	872	△	
GP-01	160		17 - 19	885				△	872	△	
GP-01	190		17 - 19	885				△	872	△	
GP-2	190		21 - 21	962				△	548		
GP-01	212		17 - 19	872*				△	872	△	

\* = 2 sets required / 2 jeux pour l'Avant.

△ = Available quality / Qualité disponible.

To select compound for racing front/rear - see page 17-20 / Pour sélectionner vos plaquettes racing avant/arrière - voir page 17-20.

**COMPOUND CHOICE****COMPOUND CHOICE**

<b>SUZUKI</b>				<b>DS-1</b>	<b>DS-2</b>	<b>DC</b>	<b>RST</b>		<b>RQ</b>	<b>LS</b>
GSX-R	600	06 - 10	806*	△	△	△	△	833	△	△
GSX-R	600	11 - 21	841*	△	△	△	△	834	△	△
SV	650 ,S ABS	07 - 18	705				△	657	△	△
GSX-R	750	06 - 10	806*	△	△	△	△	833	△	△
GSX-R	750	11 - 18	841*	△	△	△	△	834	△	△
GSX-R	1000	09 - 11	806*	△	△	△	△	834	△	△
GSX-R	1000	12 - 22	841*	△	△	△	△	834	△	△
GSX-R	1000 R	17 - 22	841*	△	△	△	△	834	△	△

<b>TRIUMPH</b>										
675	Daytona R Triple	11 - 12	901*	△	△	△	△	614	△	△
675	Daytona R Triple	13 - 18	901*	△	△	△	△	675	△	△
675	Daytona Triple	09 - 12	864*			△	△	614	△	△
675	Daytona Triple	13 - 18	864*			△	△	675	△	△
765	Daytona Moto2	20 - 22	901*	△	△	△	△	675	△	△

<b>YAMAHA</b>										
YZF	321 R3	15 - 22	931	△	△	△	△	932	△	
YZF	600 R6	03 - 16	634*	△	△	△	△	657	△	△
YZF	600 R6	17 - 22	634*	△	△	△	△	834	△	△
YZF	600 R6 Quick change / Front wheel	17 - 22	966*	△	△			834	△	△
YZF	700 R7	22 - 22	634*	△	△	△	△	657	△	△
YZF	1000 R1	15 - 22	634*	△	△	△	△	834	△	△
YZF	1000 R1 (4-pad)	07 - 14	839*	△		△	△	657	△	△
YZF	1000 R1 (4-pad) ABS	12 - 14	839*	△		△	△	657	△	△
YZF	1000 R1M	15 - 22	634*	△	△	△	△	834	△	△
YZF	1000 R1S	16 - 16	634*	△	△	△	△	834	△	△

Applications Racing

\* = 2 sets required / 2 jeux pour l'Avant.

△ = Available quality / Qualité disponible.

To select compound for racing front/rear - see page 17-20 / Pour sélectionner vos plaquettes racing avant/arrière - voir page 17-20.

# CALIPERS



**ACCOSSATO**

AGPZ01, 108 mm CNC Monoblock, 4 Piston/4 Pad	805
AGPZ02, 108 mm Forged Monoblock, 4 Piston/4 Pad	805
AGPZ03, 108 mm Forged Monoblock, 4 Piston/4 Pad	805
AGPZ04, 108 mm Forged Monoblock, 4 Piston/4 Pad	805
AGPZ05, 100 mm CNC Monoblock, 4 Piston/2 Pad	845
AGPZ06, 60 mm CNC Moto 3, 2 Piston/2 Pad	805
AGPZ07, 100 mm Forged Monoblock, 4 Piston/2 Pad	845

**A.P. RACING CALIPERS**

6 Piston 3366/3367 Series	660
6 Piston 4466/4477 Series	707
CP-2696-36E0/38E0	523
CP-2868-8E0/9E0	698
CP-3369-2E0/3E0	599
CP-3385-2E0/3E0	599
CP-3386-2E0/3E0	599
CP-3485-8S0/9S0	661
CP-3548	718
CP-3569-2S0/3S0	599
CP-3569-4S0/5S0	661
CP-3586-4S0/5S0	661
CP-3696-2E0	523
CP-3697-2E0	523
CP-3769-2S0/3S0	599
CP-4226-2S0/3S0	719
CP-4484-2S0/3S0	720
CP-4488 Two Pad Radial 4 Piston Monoblock	785
CP-4638-2E0	523
CP-6688 Four Pad Radial 4 Piston Monoblock	805

**BERINGER**

2 Piston Classic Billet Caliper	506
4 Piston Caliper	631
6 Piston Caliper	771
6 Piston Endurance Caliper	779

**BRAKING**

Front Cross	694
Front Harley Davidson	676
Rear cross (1 piston)	777
Rear cross (2 piston)	604
Street, Supermotard	706

**BREMBO RACING CALIPERS**

100 mm Motard Radial XA78910, P4 30/34	706
100 mm Radial 220A16810, P4 30/34	706
100 mm Radial 220A80310, P4 30/34	706
100 mm Radial Caliper .484, 220B47310, P4 32	841
100 mm Radial GP4 RX 220B01020 P4 32 (disc min. Th. 4.0 mm)	901
100 mm Radial GP4 RX 220B01020 P4 32 (disc min. Th. 4.5 mm)	841
100 mm Radial Monoblock 220988530, P4 34	841
100 mm Radial Monoblock XA7G210/11, P4 32/36	711
100 mm Radial Monoblock XA7G240/41, P4 32/36	711
108 mm Motard Radial XA69510, P4 30/34	706
108 mm Radial 220A01610, P4 30/34	706
108 mm Radial 220A80210, P4 30/34	706
108 mm Radial Caliper .484, 220B47310, P4 32	841
108 mm Radial GP4 RX 220B01020 P4 32 (disc min. Th. 4.0 mm)	901
108 mm Radial GP4 RX 220B01020 P4 32 (disc min. Th. 4.5 mm)	841
108 mm Radial Monoblock 220A39710, P4 34	841
108N, P2 38	506
130 mm Radial GP4 RX 220B01020 P4 32 (disc min. Th. 4.0 mm)	901
130 mm Radial GP4 RX 220B01020 P4 32 (disc min. Th. 4.5 mm)	841
Billet 20.4756.52/62, racing	566
Billet P2.24 X20.60.01, racing	732
F08	506
Floating Motocross Caliper 22.5930.62	671
Goldline 20.5161.42/51, road	519

**BREMBO RACING CALIPERS**

Goldline 20.6951.50, road	730
Goldline 4 pad 20.7850.11/21, road	762
Goldline single pin 20.5165.55/65, road	566
Goldline two pin 20.6800, road	706
GP X10.48.13/14, racing	695
Monoblock X101740/41, P4 32/36	711
Motard Axial XA32950, P4 34	762
Moto3/SBK XA88810/11, P2 34	887
Moto3/SBK XA88820/21, P2 34	887
Motocross Caliper 22.2180.20	675
Off Road 122A99021, P2 24	671
Off Road XQ21361, P2 28	671
Off Road XQ21390, PF 26	791
Racing rear X206001, P2 24	759
Racing rear X206101, P4 24 (24 mm disc height)	942
Racing rear X206101, P4 24 (30 mm disc height)	941
Racing rear X206121, P4 24 (24 mm disc height)	942
Racing rear X206121, P4 24 (30 mm disc height)	941
Racing rear X988870, P2 34 (24 mm disc height)	942
Racing rear X988870, P2 34 (30 mm disc height)	941
Racing rear XA1J040, P2 30 (24 mm disc height)	942
Racing rear XA1J040, P2 30 (30 mm disc height)	941
Radial 220A16820, P4 30/34	706
Radial GP4 RX 220B01010	841
Radial Monoblock X973760/61, P4 32/36	711
Radial Monoblock X99C460/61, P4 34	805
Radial Monoblock XA8Y310/11	845
Radial Monoblock XA93310/11	711
Radial XA3B830/31, P4 32/36	711
Radial XA3B860/61, P4 32/36	711
SBK Racing DX XB0.B1.31, P4 30/34	889
SBK Racing DX XB0.B1.31, P4 30/34 (for Radiators X93.12.50)	909
SBK Racing SX XB0.B1.30, P4 30/34	889
SBK Racing SX XB0.B1.30, P4 30/34 (for Radiators X93.12.50)	909
Supersport 120A44110, P2 34	730

**GALESPEED**

2 Piston Axial Rear Caliper, GSRCAL34AF	730
2 Piston Axial Rear Caliper, GSRCAL34AT	730
2 Piston Radial Front Caliper, GSFCAR34F(Right)/GSFCAL34F(Left)	887
2 Piston Radial Front Caliper, GSFCAR34T(Right)/GSFCAL34T(Left)	887
2 Piston Radial Rear Caliper, GSRCAL30F (30 mm Piston)	730
2 Piston Radial Rear Caliper, GSRCAL30T (30 mm Piston)	730
2 Piston Radial Rear Caliper, GSRCAL34F (34 mm Piston)	730
2 Piston Radial Rear Caliper, GSRCAL34T (34 mm Piston)	730
4 Piston Axial Front Caliper, GSFCAR3430AF (Right)/GSFCAL3430AF(Left)	695
4 Piston Axial Front Caliper, GSFCAR3430AT (Right)/GSFCAL3430AT(Left)	695
4 Piston Radial Front Caliper, GSFCAR3430F (Right)/GSFCAL3430F(Left)	695
4 Piston Radial Front Caliper, GSFCAR3430T (Right)/GSFCAL3430T(Left)	695

**GMA**

2 Piston Caliper, large Model A	512
2 Piston Caliper, small Model B	560
4 Piston front Model F	559

**HARRISON/BILLET CALIPERS**

4 Piston Billet	737
Big-6	737
Mini-6	656

**HEL**

4 Piston Billet Caliper	809
-------------------------	-----



<b>HHI</b>		<b>SJP</b>	
4 Piston Caliper	678	2 Piston Caliper (30-375)	559
6 Piston Caliper	676	4 Piston Caliper (30-370)	559
<b>ISR CALIPERS</b>			
2 Piston (22-023/026)	504		
2 Piston (22-027/028/029)	519		
2 Piston (22-030/033)	523		
2 Piston (22-036)	655		
4 Piston (22-025)	519		
4 Piston (22-043)	655		
6 Piston Racing Caliper, large	656		
6 Piston Racing Caliper, small	655		
<b>J.JUAN</b>			
Big Brake Kit X3	959		
Fixed 2p radial caliper 82mm	962		
<b>JAYBRAKE</b>			
2 Piston Caliper ADC/ADCS	560		
2 Piston Dual Series Caliper	559		
4 Piston Caliper A4 P/L	686		
4 Piston J-Four Caliper	686		
4 Piston Quad Series Caliper	559		
<b>MOTO-MASTER</b>			
Supermoto Racing Caliper	631		
<b>MOTOR FACTORY</b>			
4 Piston Caliper front/rear	678		
<b>NISSIN</b>			
3 Piston Racing Rear Caliper	766		
4 Piston Caliper	624		
4 Piston Racing Caliper (1)	711		
4 Piston Racing Caliper (2)	825		
4 Piston Racing Caliper (510-C00-91N/510-C10-91N)	950		
6 Piston Racing Caliper	729		
6 Piston Racing Radial Monobloc Caliper (Z0901)	865		
<b>PERFORMANCE MACHINE</b>			
112 X 6B	729		
112 X 6QC	729		
112 X 6RSB	683		
112 X 6SSB	683		
124 X 4HR	662		
125 X 2	559		
125 X 4R	678		
125 X 4RSPH	678		
125 X 4S	559		
125 X 4SL	559		
125 X 6	658		
125 X 6QC	683		
137 X 4	662		
137 X 4B	678		
137 X 6	658		
162 X 2	509		
4 Piston Vintage Caliper	678		
<b>PFM</b>			
6 Piston Racing Caliper	707		
<b>PVM</b>			
4 Pad Caliper	805		
<b>REVTECH</b>			
Wilwood Caliper front/rear	566		

\* = 2 sets required / 2 jeux pour l'Avant.

Compound selection, see under "Brake pad drawings" / Sélection de composés, voir sous les schémas des plaquettes de frein.

ALMOST ANY BIKE  
BRAKE PADS, CLUTCH KITS AND BRAKE ROTORS

Find the right part with  
the PRODUCT SELECTOR  
at SBSBRAKES.COM

**sbs**<sup>®</sup>  
GO AHEAD



HI-TECH BRAKE SOLUTIONS  
MADE IN EUROPE

Find the right brake pads, discs or clutches for your bike

Select the fields in any order

Brand\*  CC\*  Model\*  Year\*

SHOW MATCHES >

NEW SEARCH



@sbsbrakes | sbsbrakes.com | #GoAhead



# DRAWINGS

1:1 DRAWINGS, COMPOUNDS, FITMENTS

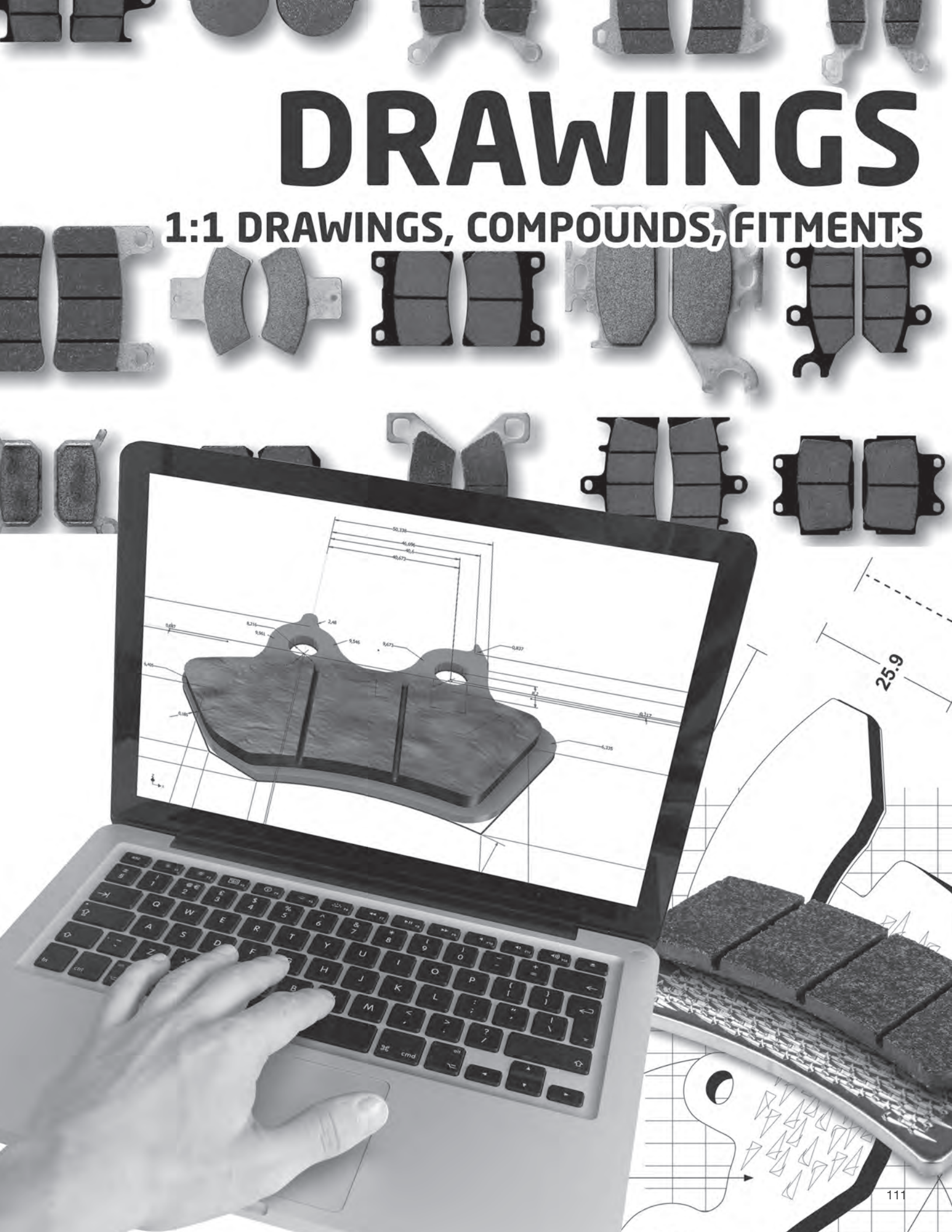

**SBS 100** Recommended compound

<b>HONDA</b>			
MB	50 S	80-82	<b>HF</b>
MBX	50	80-82	<b>HF</b>
CB	80	80-81	<b>HF</b>
<b>PEUGEOT</b>			
	50 Vivacity	08-14	<b>HF</b>
<b>SACHS</b>			
	50 MadAss 4T	05-09	<b>HF</b>
	125 MadAss	09-09	<b>HF</b>

**SBS 101** Recommended compound

<b>APRILIA</b>			
RS-4	50	12-19	<b>HF</b>
RS-4	50 Replica	16-17	<b>HF</b>
SX	50 Ltd.	07-15	<b>CT</b>
<b>BENELLI</b>			
	350 Zenzero	12-15	<b>CT</b>
<b>CPI</b>			
	50 Baby	02-02	<b>HF</b>
	50 Hussar	01-02	<b>HF</b>
	50 Mars	01-02	<b>HF</b>
	50 Popcorn	01-02	<b>HF</b>
<b>HYOSUNG</b>			
	50 Avanti	99-02	<b>HF</b>
	50 Rush	97-01	<b>HF</b>
	50 Sense	98-07	<b>HF</b>
	50 Super Cab	95-98	<b>HF</b>
	50 Super Cab Plus	98-98	<b>HF</b>
SB	50	00-03	<b>HF</b>
SB	50 P	00-03	<b>HF</b>
SD	50	00-06	<b>HF</b>
SF	50	99-06	<b>HF</b>
	100 Cab	98-01	<b>HF</b>
EZ	100	00-05	<b>HF</b>
	110 Midas Plus	98-04	<b>HF</b>
FX	110 110	02-04	<b>HF</b>
KR	110 Master	04-05	<b>HF</b>



<b>ITALJET</b>			
	100 Millennium 2T	01-01	<b>HF</b>
	125 Millennium	00-03	<b>CT</b>
	150 Millennium	00-03	<b>CT</b>
<b>KEEWAY</b>			
	50 Flash	07-12	<b>HF</b>
	50 Hurricane	06-16	<b>HF</b>
	90 Hurricane	06-09	<b>HF</b>
<b>SUZUKI</b>			
AH	50 Adress	92-95	<b>HF</b>
ZZ	50 Scooter	92-92	<b>HF</b>
AH	80 Adress, V, Tune	88-91	<b>HF</b>
AH	100 V Adress	91-94	<b>HF</b>
UE	125	01-03	<b>CT</b>
UE	150 CT	02-03	<b>CT</b>
<b>TGB</b>			
	50 101R	05-09	<b>HF</b>
	50 101S	99-02	<b>HF</b>
	50 202T	99-02	<b>HF</b>
	50 303R	99-14	<b>HF</b>
	50 309 Racing	05-05	<b>HF</b>
	50 507	05-05	<b>HF</b>
	50 Akros	99-04	<b>HF</b>
	50 Bull&t RS/RR	11-17	<b>HF</b>
	50 Bullet	09-09	<b>HF</b>
	50 Bunny	97-00	<b>HF</b>
	50 Double X	05-05	<b>HF</b>



<b>TGB</b>			
	50 Ergon	96-00	<b>HF</b>
	50 Hawk	09-14	<b>HF</b>
	50 Hiw's	99-99	<b>HF</b>
	50 Hook	10-12	<b>HF</b>
	50 J409	00-03	<b>HF</b>
	50 Tapo RS	11-12	<b>HF</b>
	50 Trigger	99-03	<b>HF</b>
R	50 X	06-14	<b>HF</b>
	90 101S	99-02	<b>HF</b>
	90 202T	99-02	<b>HF</b>
	90 Akros	99-99	<b>HF</b>
	90 Ergon	99-02	<b>HF</b>
	90 Hiw's	99-99	<b>HF</b>
	90 Trigger	99-02	<b>HF</b>
	125 101S	99-03	<b>CT</b>
	125 202T	99-99	<b>CT</b>
	125 303R	99-08	<b>CT</b>
	125 309 RS	00-00	<b>HF</b>
	125 Bull&t RS/RR	11-14	<b>HF</b>
	125 Hook	10-10	<b>HF</b>

Available compounds

HF • CT

SBS 100

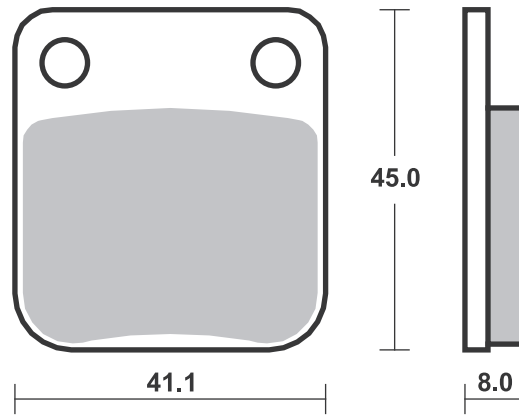

Available compounds

HF • CT • MS

SBS 101

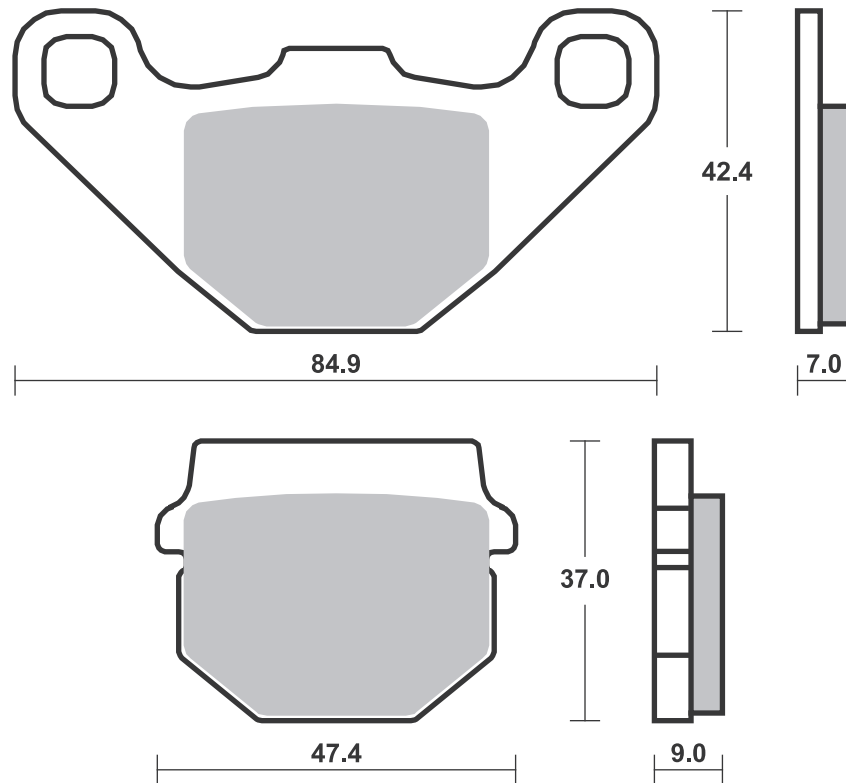

## Applications

### SBS 102 Recommended compound



<b>ADLY</b>			
	50 Panther	01-09	<b>HF</b>
	50 Silver Fox	06-09	<b>HF</b>
	50 Super Sonic	00-05	<b>HF</b>
	50 Thunderbike	97-09	<b>HF</b>
<b>RS</b>			
	50 Super Sonic	06-08	<b>HF HF</b>
	100 Panther	01-06	<b>HF</b>
	100 Silver Fox	06-06	<b>HF</b>
	100 Super Sonic	01-05	<b>HF</b>
	100 Thunderbike	01-04	<b>HF HF</b>
	125 Super Sonic	01-05	<b>CT</b>
	125 Thunderbike	01-04	<b>CT CT</b>
<b>MALAGUTI</b>			
	125 Monte	20-20	<b>CT</b>
<b>PEUGEOT</b>			
	50 Speedake		
	(Hengtong cal.)	94-01	<b>HF</b>
	50 Speedfight LC,		
	(Hengtong cal.)	96-15	<b>HF</b>
	50 Trekker Offroad	99-01	<b>HF</b>
	50 Vivacity		
	(Hengtong cal.)	05-07	<b>HF</b>
	100 Vivacity		
	(Hengtong cal.)	05-07	<b>HF</b>
<b>SUZUKI</b>			
AH	80 Scooter	92-94	<b>HF</b>

### SBS 103 Recommended compound



<b>CAGIVA</b>			
	125 Stella	97-08	<b>CT</b>
<b>HONDA</b>			
NS-1	50	91-94	<b>HF</b>
NSR	50	89-90	<b>HF</b>
NSR	80 R	87-92	<b>HF</b>
<b>HYOSUNG</b>			
	125 Boomer	03-03	<b>CT</b>
	125 Exceed	02-06	<b>CT</b>
	150 Exceed	02-04	<b>CT</b>
<b>SYM</b>			
	125 Wolf Legend	02-05	<b>CT</b>

Available compounds

HF • CT

SBS 102

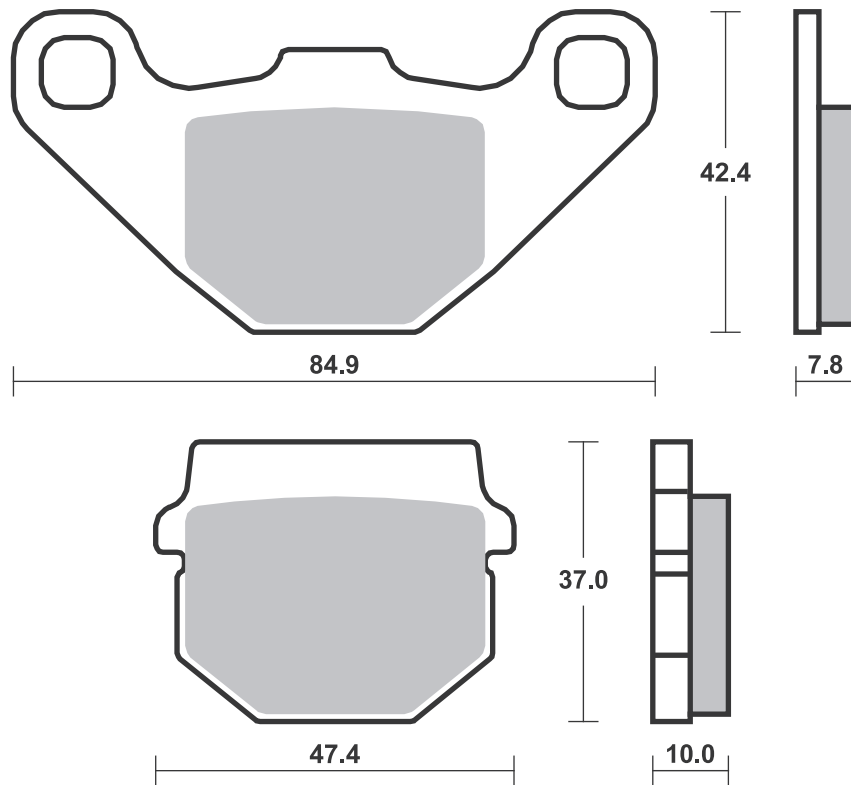

Available compounds

HF • CT

SBS 103

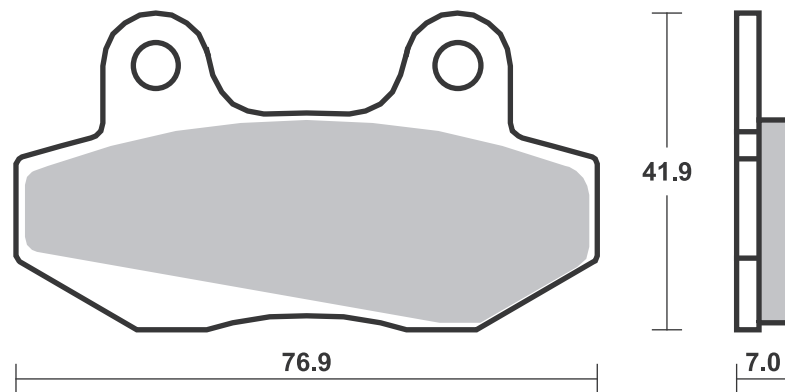

**SBS 104 Recommended compound**

<b>HONDA</b>			
NH	100 Lead	00-08	<b>HF</b>
NHX	110	10-12	<b>CT</b>
NES	125 @	01-06	<b>CT</b>
NES	150 @	01-06	<b>CT</b>
<b>SUZUKI</b>			
AN	250 Burgman	98-03	<b>MS</b>
AN	400 Burgman	99-00	<b>MS</b>

**SBS 105 Recommended compound**

<b>CPI</b>			
50 Supermoto,			
Supercross	03-09	<b>HF</b>	<b>HF</b>
<b>DERBI</b>			
50 Atlantis	99-08	<b>HF</b>	
50 Atlantis 4T	04-10	<b>HF</b>	
50 Atlantis Bullet	04-05	<b>HF</b>	
50 Atlantis H2O	01-01	<b>HF</b>	
50 Atlantis H2O			
Wave	01-01	<b>HF</b>	
50 Atlantis Wave	01-02	<b>HF</b>	
50 Aventura	96-96	<b>HF</b>	
50 Black Devil	04-04	<b>HF</b>	<b>HF</b>
50 DRD Pro corse	06-08	<b>HF</b>	<b>HF</b>
50 DRD Racing R	05-10	<b>HF</b>	<b>HF</b>
50 DRD Racing R			
Ltd.	05-05	<b>HF</b>	<b>HF</b>
50 DRD Racing SM	05-05	<b>HF</b>	<b>HF</b>
50 DRD Racing SM			
Ltd.	05-05	<b>HF</b>	<b>HF</b>
50 Fenix	94-07	<b>HF</b>	<b>HF</b>
50 Furax	96-98	<b>HF</b>	<b>HF</b>
50 Hunter	97-99	<b>HF</b>	
50 Manhattan	99-99	<b>HF</b>	
50 Predator LC	99-02	<b>HF</b>	<b>HF</b>
50 Predator O2	00-02	<b>HF</b>	<b>HF</b>
50 Rambla	06-06	<b>HF</b>	<b>HF</b>
50 Savannah	91-97	<b>HF</b>	
50 Senda L	99-01	<b>HF</b>	<b>HF</b>
50 Senda R DRD	03-04	<b>HF</b>	
50 Senda R,			
X-Treme	94-04	<b>HF</b>	<b>HF</b>
50 Senda SM DRD	03-04	<b>HF</b>	<b>HF</b>
50 Senda SM DRD			
Black Edition	03-04	<b>HF</b>	
50 Senda SM,			
X-Treme	99-06	<b>HF</b>	<b>HF</b>
50 Stinger	96-96	<b>HF</b>	<b>HF</b>
50 Vamos FL	95-99	<b>HF</b>	
50 Vamos L	95-95	<b>HF</b>	
50 Vamos R			
(A.J.P. cal.)	95-95	<b>HF</b>	



<b>DERBI</b>			
50 Variant Sport-R	01-13	<b>HF</b>	
50 X-Race R	05-09	<b>HF</b>	<b>HF</b>
50 X-Treme R	05-05	<b>HF</b>	<b>HF</b>
GP 50	01-01	<b>HF</b>	
GP1 50	01-03	<b>HF</b>	<b>HF</b>
GPR 50 R	98-03	<b>HF</b>	
GPX1 50	06-06	<b>HF</b>	<b>HF</b>
ST 50 Paddock	96-99	<b>HF</b>	
100 Atlantis 4T	04-06	<b>HF</b>	
100 Atlantis O2/H2O	01-01	<b>HF</b>	
125 Predator	99-99	<b>CT</b>	
<b>HUSQVARNA</b>			
50 Racing	98-98	<b>HF</b>	
SM 50	02-02		<b>HF</b>
<b>ITALJET</b>			
50 Dragster	99-06	<b>HF</b>	<b>HF</b>
50 Formula Air	99-00	<b>HF</b>	
50 Formula L.C.	98-00	<b>HF</b>	<b>HF</b>
50 Torpedo	98-99	<b>HF</b>	
50 Torpedo 4T	01-03	<b>HF</b>	
125 Dragster	99-03	<b>CT</b>	<b>CT</b>
125 Formula L.C.	99-03	<b>CT</b>	<b>CT</b>
125 Jupiter	02-03		<b>CT</b>
125 Torpedo	99-06	<b>CT</b>	
125 Twin	98-01	<b>CT</b>	<b>CT</b>
150 Jupiter	02-03		<b>CT</b>
150 Torpedo 4T	01-01	<b>CT</b>	
180 Dragster	99-03	<b>CT</b>	<b>CT</b>
<b>PEUGEOT</b>			
50 Elyseo	02-05	<b>HF</b>	<b>HF</b>
50 Elyseo			
(A.J.P. cal.)	99-01	<b>HF</b>	
50 Elystar	03-05	<b>HF</b>	
50 Looxor	02-05	<b>HF</b>	
50 Looxor	06-06	<b>HF</b>	<b>HF</b>
50 Speedake			
(A.J.P. cal.)	94-01	<b>HF</b>	
50 Speedfight 2 A/C	01-08	<b>HF</b>	
50 Speedfight 2 L/C	01-08	<b>HF</b>	<b>HF</b>



<b>PEUGEOT</b>			
50 Speedfight 2			
X-Race, Furious,			
206 WRC	01-02	<b>HF</b>	<b>HF</b>
50 Speedfight			
LBD/LBDP	00-00	<b>HF</b>	<b>HF</b>
50 Speedfight LC,			
(A.J.P. cal.)	96-15	<b>HF</b>	
50 Speedfight			
Lemans	11-11	<b>HF</b>	<b>HF</b>
50 Trekker Metal-X	01-08	<b>HF</b>	
50 Trekker Road	99-00	<b>HF</b>	
50 Trekker			
Streetboard	00-02	<b>HF</b>	
50 Trekker Urban			
Black	00-00	<b>HF</b>	
50 Vivacity			
(A.J.P. cal.)	99-07	<b>HF</b>	
100 Elyseo	02-05	<b>HF</b>	<b>HF</b>
100 Elyseo			
(A.J.P. cal.)	99-01	<b>HF</b>	
100 Looxor	02-07	<b>HF</b>	<b>HF</b>
100 Speedfight	00-07	<b>HF</b>	<b>HF</b>
100 Speedfight 2,			
X-Race	01-07	<b>HF</b>	<b>HF</b>
100 Trekker Road	99-04	<b>HF</b>	
100 Vivacity			
(A.J.P. cal.)	99-07	<b>HF</b>	
125 Elyseo			
(A.J.P. cal.)	99-99	<b>CT</b>	
<b>TOMOS</b>			
50 Hip Hop	06-08	<b>HF</b>	
50 Racing	06-08	<b>HF</b>	
50 Street Soul	06-08	<b>HF</b>	
50 Youngst'r	06-08	<b>HF</b>	
SE 50	05-06		<b>HF</b>
<b>YAMAHA</b>			
TZR 50	03-04		<b>HF</b>

Available compounds

HF • CT • MS

SBS 104

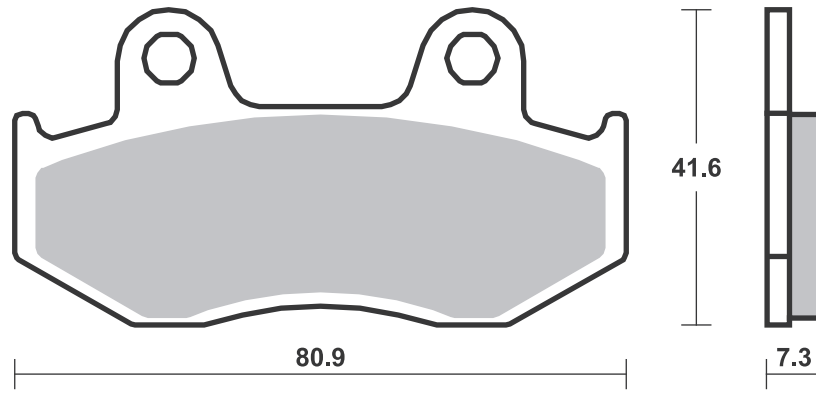

Available compounds

HF • CT

SBS 105

If required with springs -  
see SBS 188

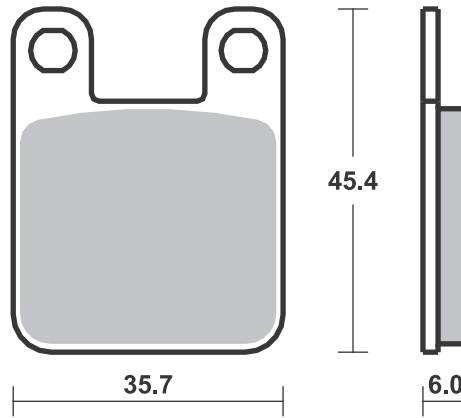

**SBS 107** Recommended compound



**YAMAHA**

DT	50 R	89-97	HF
TDR	50	90-92	HF HF
TZM	50 R	94-97	HF
TZR	50	90-92	HF
XC	125 Cygnus F	00-08	CT
XC	125 F	00-08	CT
XC	125 TR Cygnus, R	96-98	CT
XC	150 Fly One R	98-02	CT

**SBS 108** Recommended compound



**APRILIA**

	200 Sportcity	04-08	CT
--	---------------	-------	----

**DERBI**

	125 Rambla	08-14	CT
	300 Rambla	08-12	MS

**MALAGUTI**

	125 Runner	87-87	CT
--	------------	-------	----

Brake Pad 1:1 Drawings, Compounds, Fitments



Available compounds

HF • CT

SBS 107

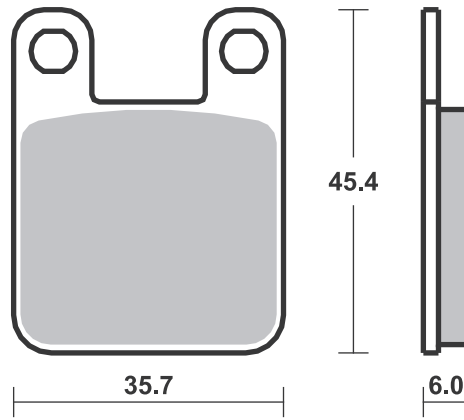

Available compounds

HF • CT • MS

SBS 108

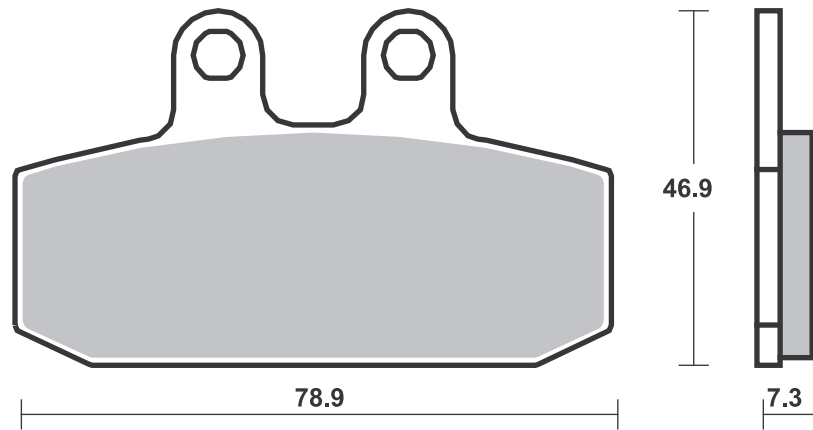

# Applications

## SBS 109 Recommended compound



MALAGUTI			
	50 Centro	93-96	HF
F-15	50 Fire Fox L.C.	96-08	HF

## SBS 110 Recommended compound



HONDA			
NH	50 Lead	86-93	HF
SYM			
	50 Bullet	93-93	HF
	50 Cinderella	01-00	HF
	50 Mio	05-16	HF
DD	50	02-12	HF
	100 Cinderella	01-01	HF
	100 Mio	05-16	HF

## SBS 111 Recommended compound



ADLY			
	25 Silver Fox	00-05	HF
	50 Cat	01-08	HF
	50 Cosy	01-08	HF
	50 Fox	00-09	HF
	50 Fox Plus	01-09	HF
	50 Jet	96-99	HF
	50 Pista, Pista Twin		
	Light	96-99	HF
	50 Silver Fox	00-05	HF
RT	50 Road Tracer	02-06	HF
	70 Fox Plus	01-05	HF
	70 Pista, Pista Twin		
	Light	01-05	HF
	80 Cosy	01-06	HF
RT	90 Road Tracer	02-06	HF
	100 Cat	01-08	HF
	100 Jet	96-99	HF



ADLY			
	100 Silver Fox	01-05	HF
RT	100 Road Tracer	02-06	HF
	125 Cat	01-04	CT
ITALJET			
	50 Bazooka	93-02	HF
	50 Cruise	95-97	HF
	50 Pista 2	92-97	HF
	50 Scoop	93-97	HF
	50 Yankee 8	94-02	HF HF
TGB			
	250 Dynasty	06-06	CT
YAMAHA			
	50 Axis Pro Foot	92-99	HF
CR	50 Target	91-95	HF



YAMAHA			
CR	50 Z	91-95	HF
JOG	50 R	02-07	HF
YW	50 Zuma	02-11	HF
JOG	90	90-91	HF

Brake Pad 1:1 Drawings,  
Compounds, Fitments

Available compounds

HF

SBS 109

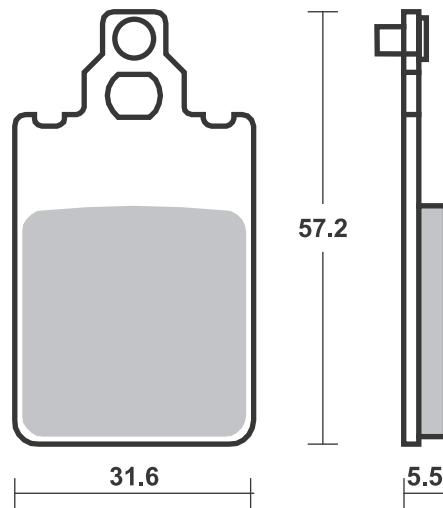

Available compounds

HF • CT

SBS 110

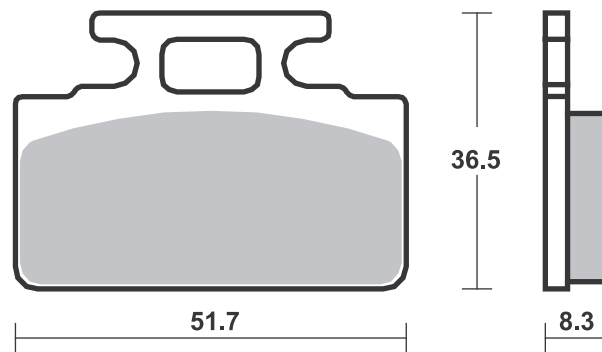

Available compounds

HF • CT

SBS 111

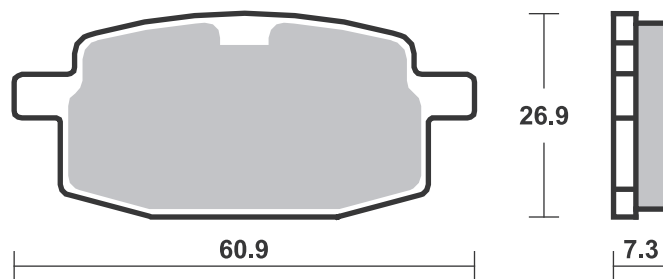

**SBS 112 Recommended compound**



<b>HONDA</b>			
NH	50 Lead SS,MR,		
	MSE	84 - 85	<b>HF</b>
NH	125 Lead Scooter	86 - 87	<b>CT</b>

**SBS 113 Recommended compound**



<b>KYMCO</b>			
	125 Agility City	11 - 17	<b>CT</b>
<b>MALAGUTI</b>			
F-10	50	92 - 93	<b>HF</b>

Brake Pad 1:1 Drawings, Compounds, Fitments

Available compounds

HF • CT

SBS 112

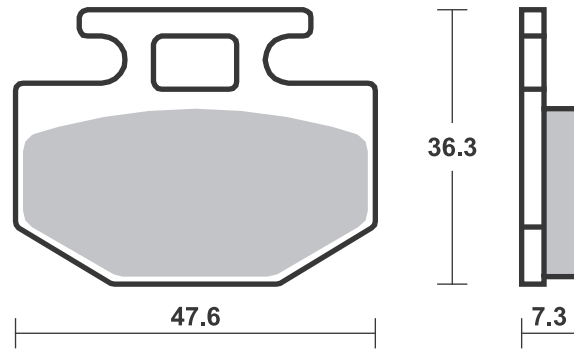

Available compounds

HF • CT

SBS 113

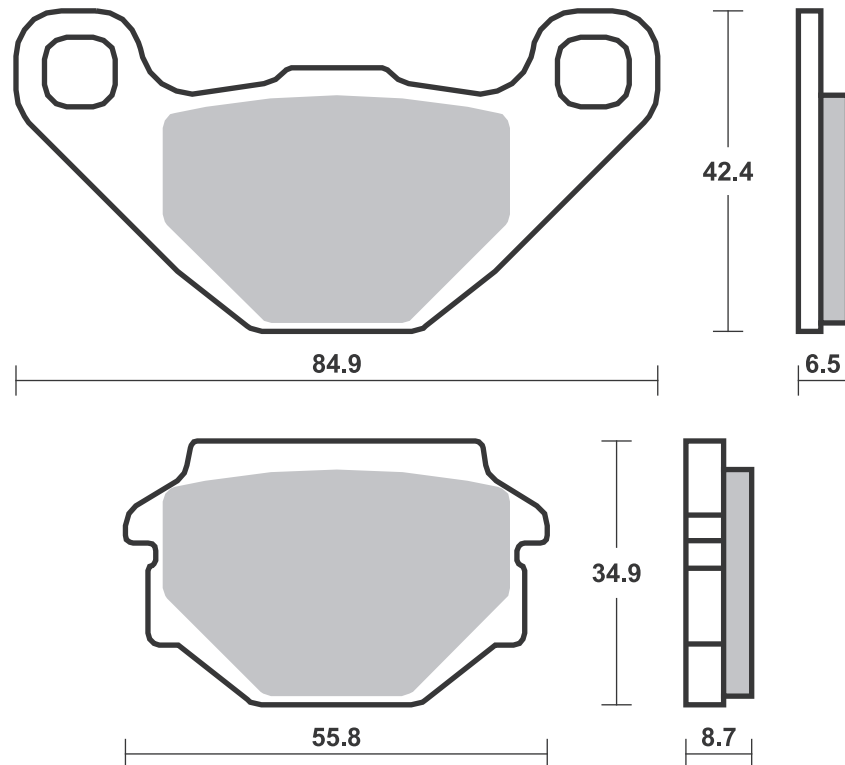

# Applications

## SBS 114 Recommended compound



### YAMAHA

JOG-Z	50	90-91	HF
YE	50 Zest (Italy)	92-95	HF
YM	50 Breeze, Fizz	95-95	HF
YE	80 Zest (Italy)	93-94	HF

## SBS 115 Recommended compound



### SYM

	50 Super Fancy	98-06	HF

## SBS 117 Recommended compound



### APRILIA

SR	50 Replica	94-96	HF

### ITALJET

	50 Formula	94-00	HF
	80 Formula	94-97	HF
	125 Formula	94-03	CT

Brake Pad 1:1 Drawings, Compounds, Fitments

Available compounds

HF • CT

SBS 114

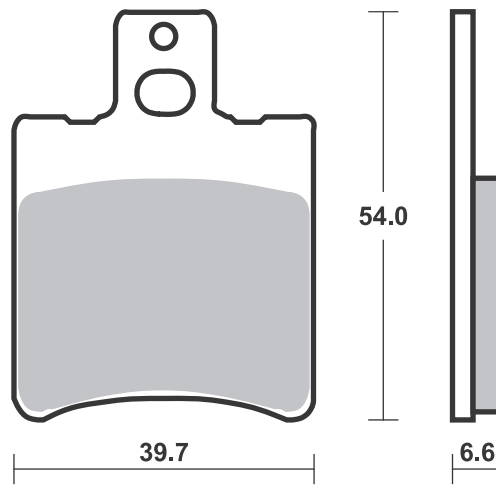

Available compounds

HF • CT

SBS 115

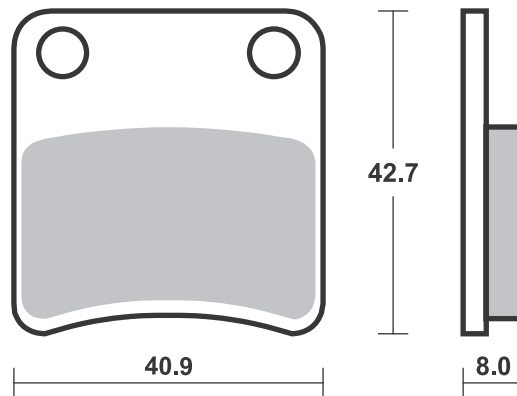

Available compounds

HF • CT

SBS 117

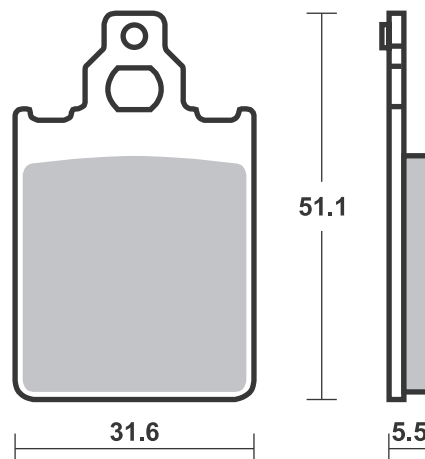

**Applications**

**SBS 119 Recommended compound**



<b>HONDA</b>			
NS-1	75	92-00	HF
NSR	80 R	93-95	HF
<b>ITALJET</b>			
	50 Rollercraft	08-12	HF
	125 Torpedo	08-11	CT
	150 Torpedo	08-12	CT
<b>KEEWAY</b>			
	100 Partner	06-10	HF
	110 Partner	06-07	HF
	125 Speed	06-12	CT
	150 Speed	06-09	CT
<b>KYMCO</b>			
	50 Super-9 A/C	02-07	HF
	50 Super-9 L/C	02-07	HF
	125 Agility 16+	14-16	CT
	150 Quannon	10-14	CT CT
	200 Agility 16+	14-17	CT
	200 Agility R16	11-15	CT
	200 Like i	10-16	CT CT
	250 People	03-12	MS
<b>SYM</b>			
RS	125	05-06	CT
RS	150	05-06	CT

**SBS 120 Recommended compound**



<b>CPI</b>			
	50 GTR	02-02	HF
	50 GTS	02-03	HF
	125 GTR, GTS	02-03	CT
	200 GTR, GTS	02-03	CT
<b>MALAGUTI</b>			
R	125 Madison	99-09	CT

Brake Pad 1:1 Drawings, Compounds, Fitments



Available compounds

HF • CT • MS

SBS 119

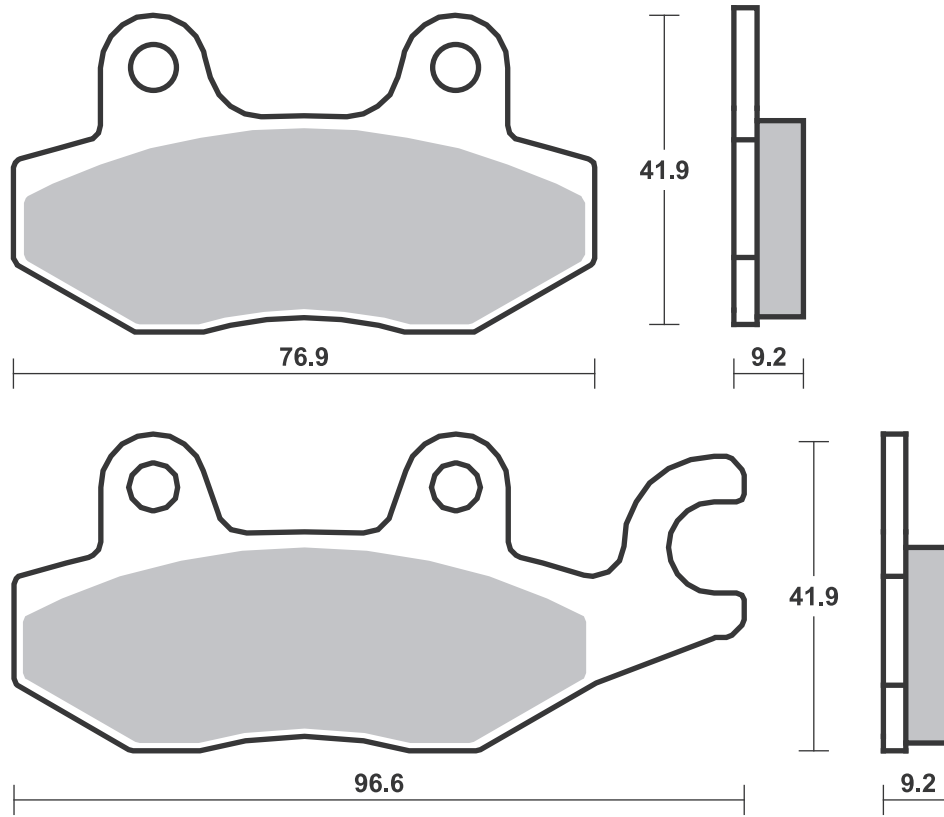

Available compounds

HF • CT • MS

SBS 120

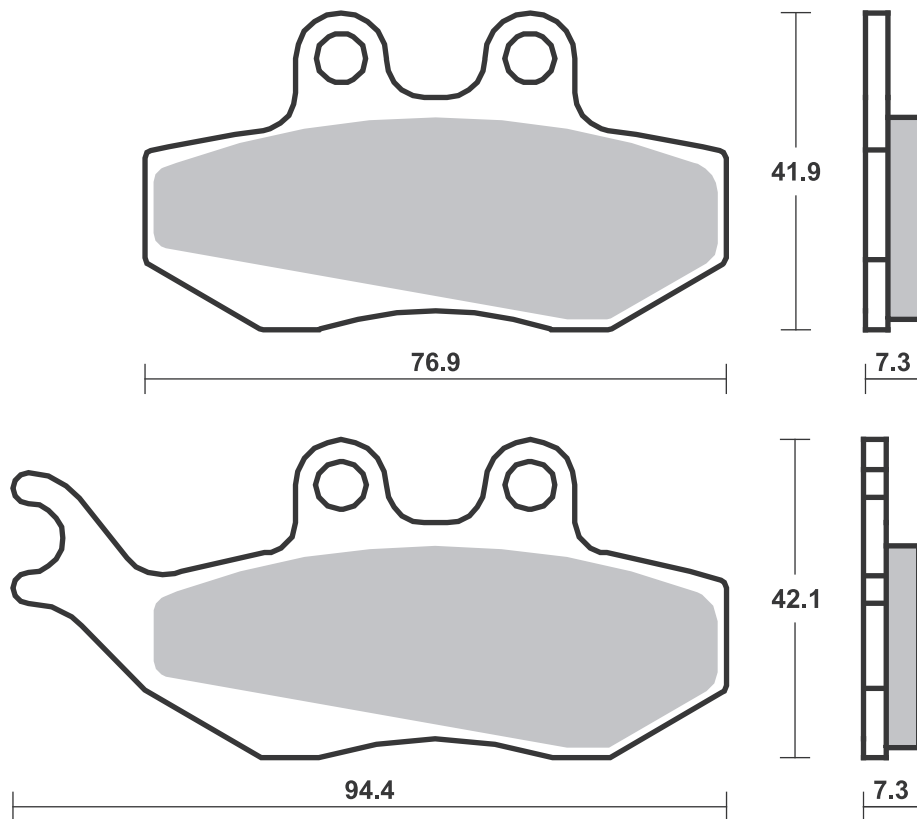

# Applications

## SBS 121 Recommended compound



<b>HONDA</b>			
NH	50 Lead	94-94	<b>HF</b>
NS-1	75	92-00	<b>HF</b>
NSR	80 R	87-95	<b>HF</b>
NH	90 Yupy	90-94	<b>HF</b>
NS	150	92-95	<b>HF</b>

<b>ITALJET</b>			
	125 Amarcord	08-16	<b>HF</b>

<b>KYMCO</b>			
CX	50 Curio Super	94-97	<b>HF</b>

## SBS 122 Recommended compound



<b>SUZUKI</b>			
UK	110 Adress	15-19	<b>HF</b>
UC	125 Epicuro	99-02	<b>CT</b>

Brake Pad 1:1 Drawings,  
Compounds, Fitments

Available compounds

HF

SBS 121

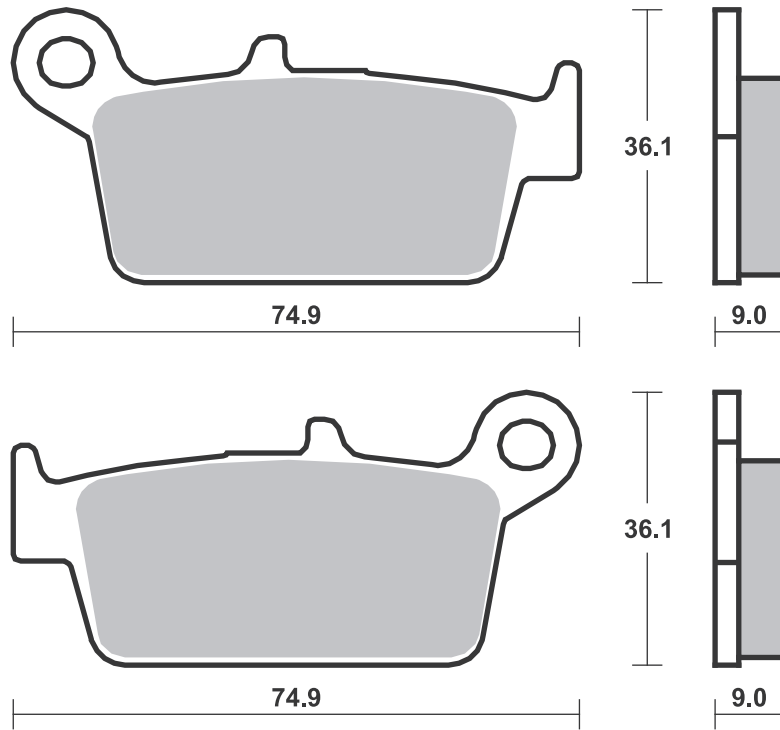

Available compounds

HF • CT

SBS 122

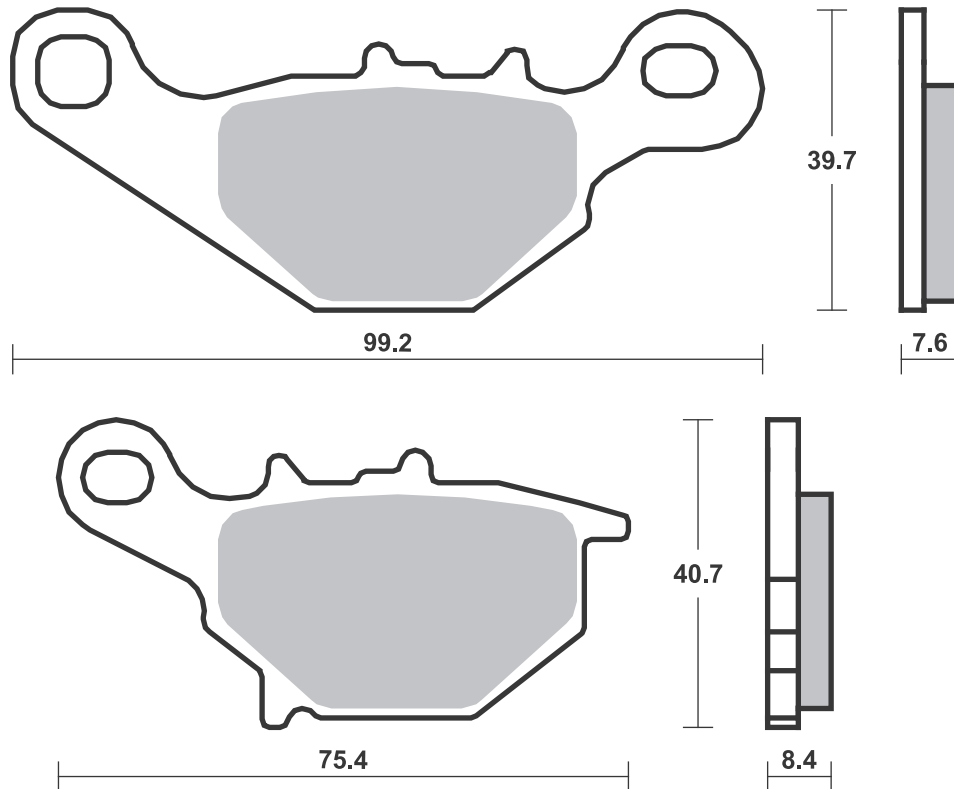

# Applications

## SBS 123 Recommended compound



APRILIA			
SR	50 Ditech	01-06	HF
SR	50 Racing	00-04	HF
SR	50 Replica (Liquid Cooled)	96-96	HF
SR	50 Stealth, Racing	97-00	HF HF
SR	50 Street	05-12	HF
CPI			
	50 GTR	03-09	HF
DERBI			
	50 Vamos R (Brembo cal.)	95-95	HF
HONDA			
	50 Formula	94-98	HF
HYOSUNG			
	125 Boomer	03-03	CT
	125 Exceed	02-06	CT
	125 Grand Prix	98-04	CT



HYOSUNG			
	125 Hyper	99-09	CT
GPS	125 D	00-03	CT
	150 Exceed	02-04	CT
	150 Grand Prix	98-01	CT
ITALJET			
	50 Formula	94-00	HF
	80 Formula	94-97	HF
	125 Formula	94-03	CT
KEEWAY			
	125 Arn	06-08	CT
	150 Arn	06-08	CT
MALAGUTI			
	50 Yesterday	97-02	HF
EL	50 Crosser	97-00	HF
F-10	50 Jet-Line	94-98	HF
F-12	50 Phantom A.C.	99-03	HF
SL	50 Centro	96-00	HF



PEUGEOT			
	50 Speedake (Brembo cal.)	94-01	HF
	50 Speedfight LC, (Brembo cal.)	96-15	HF
TOMOS			
	50 Revival	02-04	HF
	50 Streetmate	03-05	HF
YAMAHA			
BW	50 Bump	97-02	HF
BW	50 Next Generation	96-07	HF
BW	50 Sports Spec R	02-06	HF
BW	50 Spy	95-03	HF
YN	50 Neo's, LC	97-16	HF
	100 Aerox	00-06	HF

## SBS 125 Recommended compound



HONDA			
NHX	110	08-09	HF
PS	125 i	07-13	CT
SES	125 Dylan	02-07	CT
SH	125	02-08	CT
PS	150 i	07-11	CT
SES	150 Dylan	02-06	CT
SH	150	02-08	CT

## SBS 127 Recommended compound



HONDA			
CN	250	93-04	CT

Brake Pad 1:1 Drawings, Compounds, Fitments

Available compounds

HF • CT

SBS 123

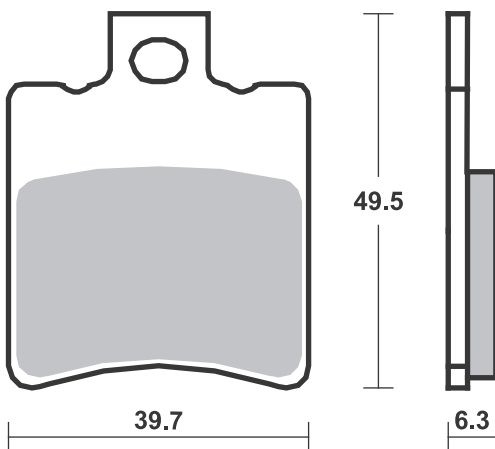

Available compounds

HF • CT • MS

SBS 125

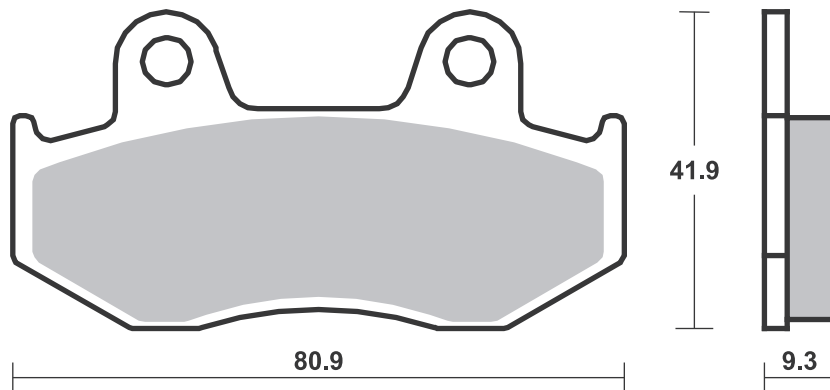

Available compounds

HF • CT

SBS 127

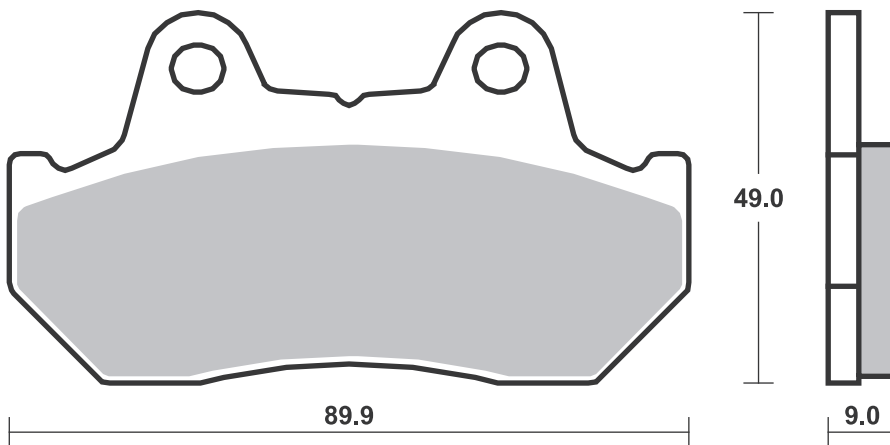

**SBS 128** Recommended compound**ITALJET**

	125 Jupiter	02-03	<b>CT</b>
	150 Jupiter	02-03	<b>CT</b>
	250 Jupiter	01-03	<b>CT</b>

**YAMAHA**

YP	250 D Majesty DX	98-00	<b>MS</b>
YP	250 Majesty	96-04	<b>MS</b>
YP	250 Majesty DX/ABS	99-14	<b>MS</b>
YP	400 Majesty	05-13	<b>MS</b>
XP	500 TMAX	04-07	<b>MS</b>

**SBS 129** Recommended compound**SYM**

	50 Jet Sport X SR	06-14	<b>HF</b>
--	-------------------	-------	-----------

**SBS 132** Recommended compound**KEEWAY**

	125 Speed	06-12	<b>CT</b>
	150 Speed	06-09	<b>CT</b>

**MALAGUTI**

	50 Enduro Dune	87-88	<b>HF</b>	<b>HF</b>
CR-1	50 Crosser	95-96	<b>HF</b>	
F-12	50 Phantom	94-98	<b>HF</b>	
F-15	50 Fire Fox	96-08	<b>HF</b>	

**TGB**

	50 Corona	03-05	<b>HF</b>
R	50 X	06-14	<b>HF</b>

Available compounds

HF • CT • MS

SBS 128

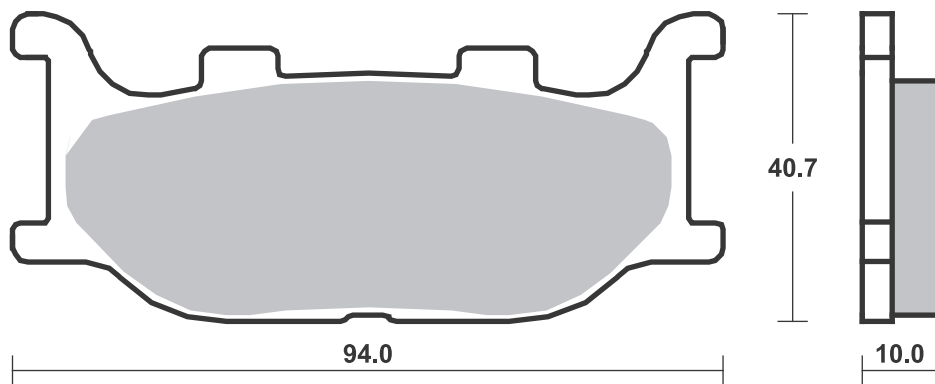

Available compounds

HF • CT

SBS 129

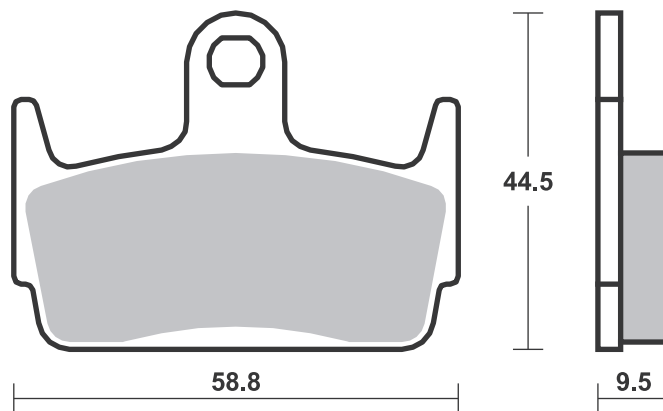

Available compounds

HF • CT

SBS 132

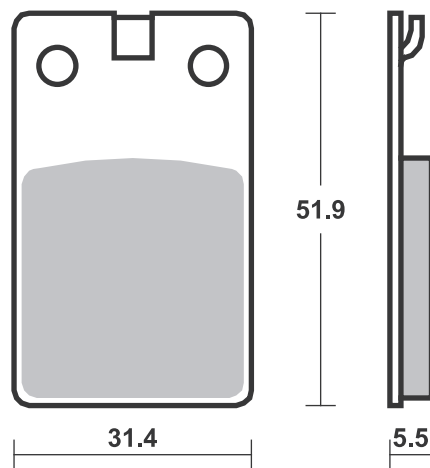

# Applications

## SBS 134 Recommended compound



### PIAGGIO VESPA

300 Beverly hpe	22-22	MS
-----------------	-------	----

### SUZUKI

UH 200 Burgman	14-18	CT
----------------	-------	----

### YAMAHA

TZM 50 R	94-97	HF
TZR 50	90-02	HF

## SBS 135 Recommended compound



### SUZUKI

GSXR 50	87-87	HF
OR 50 E	80-80	HF
RG 50 GAG	87-92	HF
RG 50 Gamma	90-96	HF
ZR 50	81-87	HF

### SYM

125 Husky	96-98	CT
-----------	-------	----

Brake Pad 1:1 Drawings,  
Compounds, Fitments



Available compounds

HF • CT • MS

SBS 134

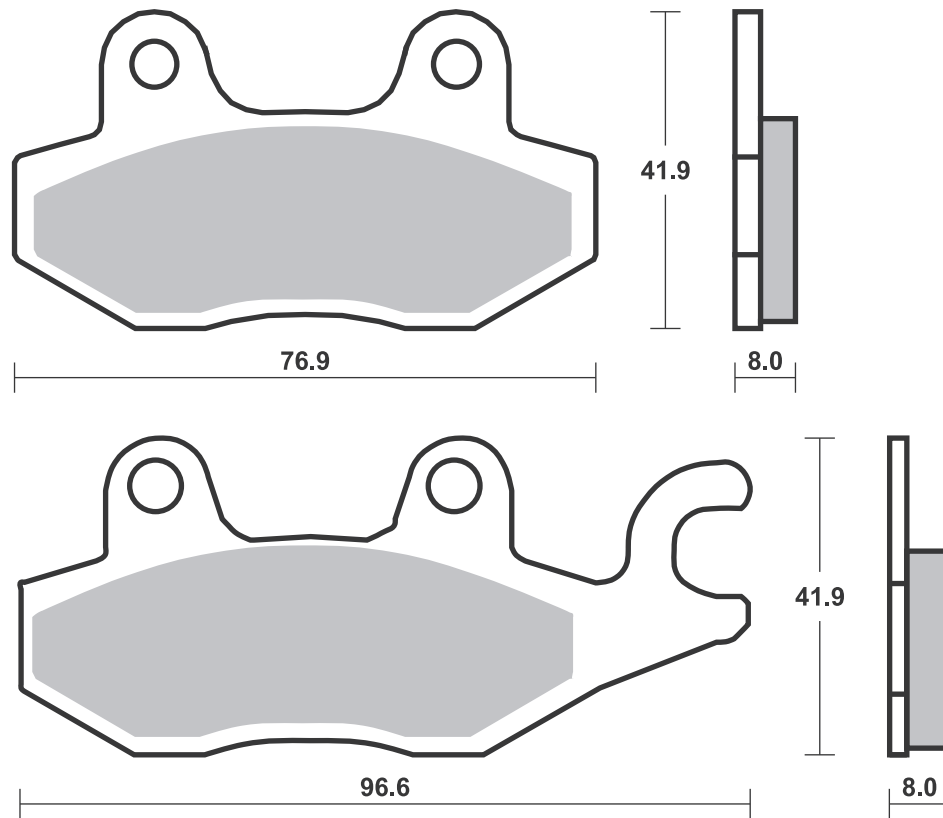

Available compounds

HF • CT

SBS 135

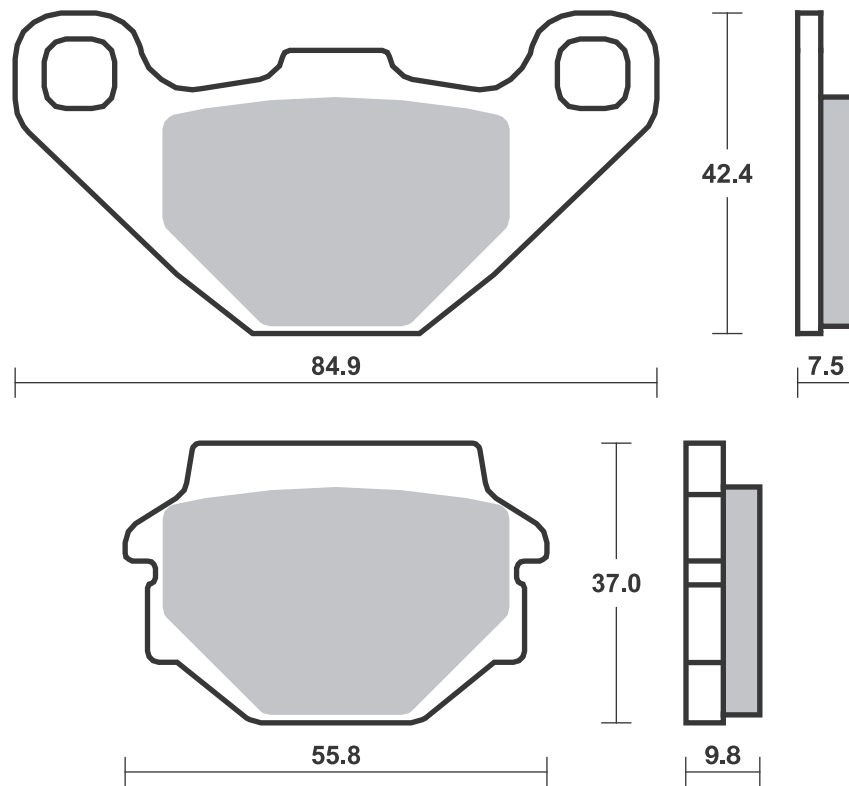



Available compounds

HF • CT

SBS 137

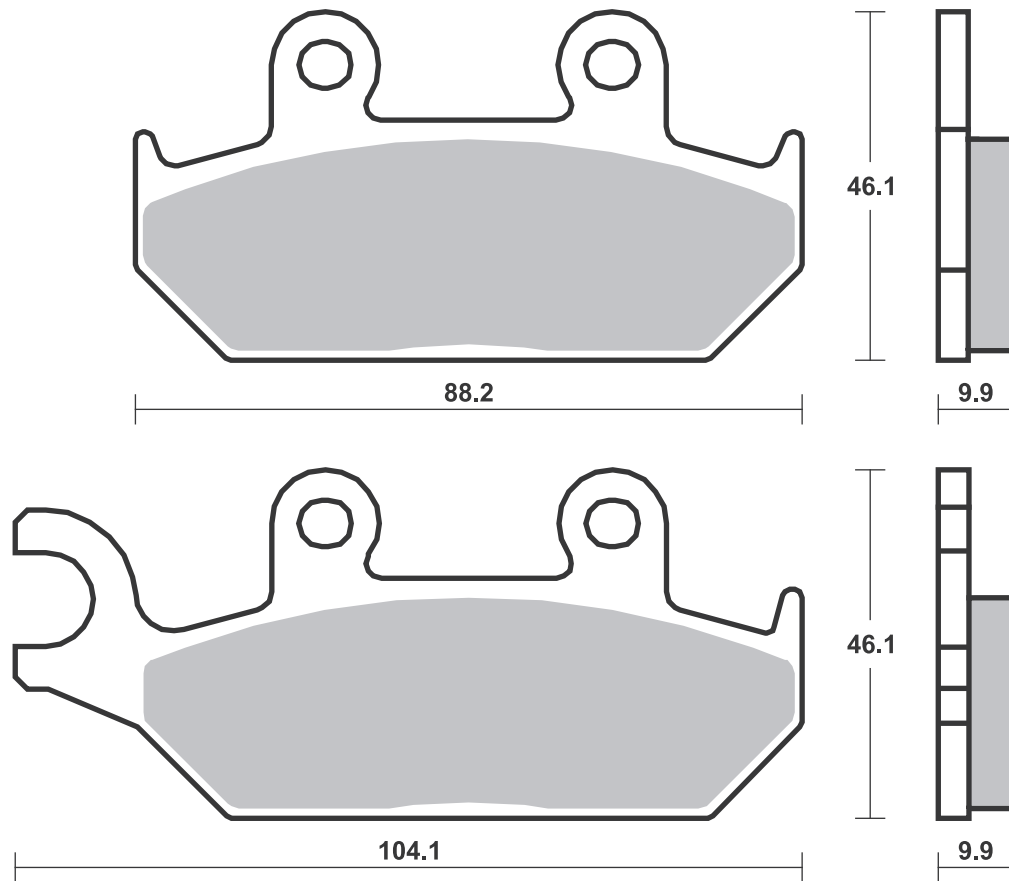

Available compounds

HF • CT

SBS 138

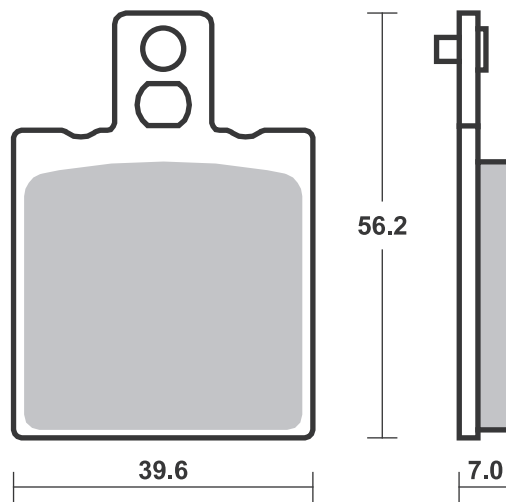

**SBS 140** Recommended compound

<b>SYM</b>			
50 Allo	11-15	<b>HF</b>	
50 Crox	14-15	<b>CT</b>	
50 Fiddle	09-14	<b>HF</b>	
50 Fiddle III	16-19	<b>CT</b>	
50 Jet 4 Naked	11-13	<b>HF</b>	
50 Jet 4 R	11-13	<b>HF</b>	
50 Jet BasiX	07-09	<b>HF</b>	
50 Jet Euro X	05-12	<b>HF</b>	
50 Jet Sport X	06-14	<b>HF</b>	
50 Jet Sport X SR	06-14	<b>HF</b>	
50 Jet, Alpha	95-97	<b>HF</b>	
50 Jungle	96-02	<b>HF</b>	
50 Mask	00-05	<b>HF</b>	
50 Mask LC	00-05	<b>HF</b>	
50 Orbit II	12-13	<b>HF</b>	
50 Red Devil	97-09	<b>HF</b>	
50 Super Fancy	95-97	<b>HF</b>	
50 Symphony	09-15	<b>HF</b>	
50 Symphony SR	11-15	<b>HF</b>	
50 Symphony ST	15-15	<b>CT</b>	
50 Symply	08-14	<b>HF</b>	
50 X'Pro	13-17	<b>HF</b>	
100 Jet	00-00	<b>HF</b>	
100 Jet Euro X	05-05	<b>HF</b>	
100 Jet Sport X	05-05	<b>HF</b>	
100 Party	97-00	<b>HF</b>	
100 Super Fancy	95-00	<b>HF</b>	
110 Star	03-03	<b>HF</b>	
125 Allo	11-15	<b>CT</b>	
125 Citycom	09-14	<b>CT</b>	



<b>SYM</b>			
125 Crox	14-15	<b>CT</b>	
125 Fiddle	09-16	<b>CT</b>	
125 Fiddle III	16-19	<b>CT</b>	
125 Jet 14	17-19	<b>CT</b>	
125 Jet 4	11-13	<b>HF</b>	
125 Megalo	02-05	<b>CT</b>	
125 New Duke	02-07	<b>CT</b>	
125 Super Duke	95-01	<b>CT</b>	
125 Symphony	09-15	<b>CT</b>	
125 Symphony EX	17-17	<b>CT</b>	
125 Symphony S	11-17	<b>CT</b>	
125 Symphony SR	11-17	<b>CT</b>	
125 Symphony ST	15-19	<b>CT</b>	
125 Symply	08-14	<b>CT</b>	
125 X'Pro	14-16	<b>CT</b>	
HD 125 Evo DT	10-10	<b>CT</b>	
HD2 125 Evo	14-14	<b>CT</b>	
150 Attila	00-03	<b>CT</b>	
150 Crox	14-16	<b>CT</b>	
150 Jet 4	11-14	<b>HF</b>	
150 Super Duke	96-01	<b>CT</b>	
150 Symphony S	11-15	<b>CT</b>	
150 Symphony SR	11-15	<b>CT</b>	
200 Fiddle II	11-13	<b>CT</b>	
200 Fiddle III	16-19	<b>CT</b>	
200 Joyride Evo	09-15	<b>CT</b>	
HD 200 Evo	07-13	<b>CT</b>	
HD2 200 Evo	14-14	<b>CT</b>	
300 Citycom	09-15	<b>CT</b>	<b>CT</b>
300 Citycom S	15-17	<b>CT</b>	<b>CT</b>

**SBS 141** Recommended compound

<b>GPI</b>			
50 Aragon Club	07-09	<b>HF</b>	
50 Aragon GP	06-09	<b>HF</b>	
50 Aragon SP	07-09	<b>HF</b>	
50 Freaky	07-07	<b>HF</b>	
50 Hussar	03-06	<b>HF</b>	
50 Oliver	03-12	<b>HF</b>	
50 Oliver City	03-12	<b>HF</b>	
50 Oliver Sport	03-12	<b>HF</b>	
50 Popcorn	03-06	<b>HF</b>	
125 Aragon GP	07-12	<b>CT</b>	

<b>ITALJET</b>			
SX1 50	08-10	<b>HF</b>	

<b>KEEWAY</b>			
50 Flash Electric	10-12	<b>HF</b>	
50 Focus	06-15	<b>HF</b>	
50 Matrix	06-15	<b>HF</b>	
50 Matrix Electric	10-15	<b>HF</b>	
50 Matrix Racing			
Sport	10-16	<b>HF</b>	
F-NKD 50	10-11	<b>HF</b>	
RY8 50	07-16	<b>HF</b>	
125 Focus	06-08	<b>CT</b>	
125 Matrix	06-08	<b>CT</b>	
125 Matrix Racing			
Sport	10-16	<b>CT</b>	
150 Focus	06-09	<b>CT</b>	
150 Matrix	06-08	<b>CT</b>	



<b>KEEWAY</b>			
150 Matrix Racing			
Sport	10-12	<b>CT</b>	

<b>PEUGEOT</b>			
50 Vivacity Sportline	11-11	<b>HF</b>	

<b>TGB</b>			
GT 50 Veloce	09-12	<b>HF</b>	

Available compounds

HF • CT

SBS 140

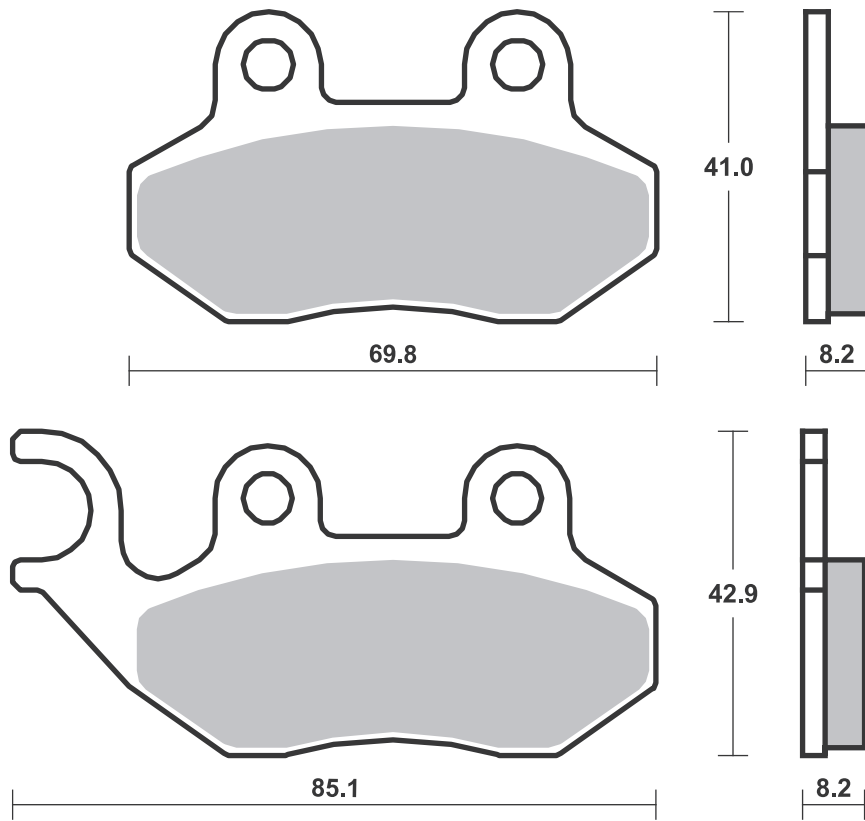

Available compounds

HF • CT

SBS 141

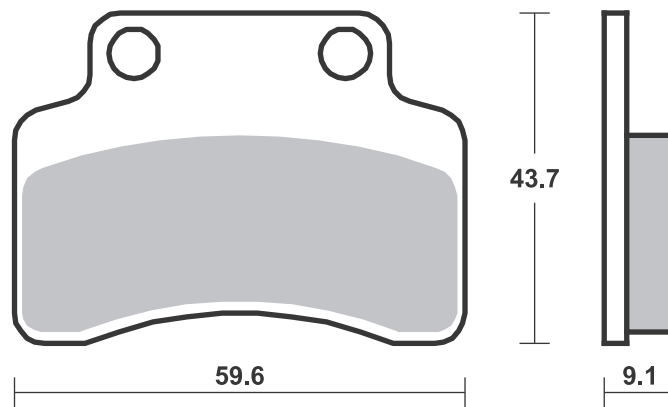



Available compounds

HF • CT • MS

SBS 142

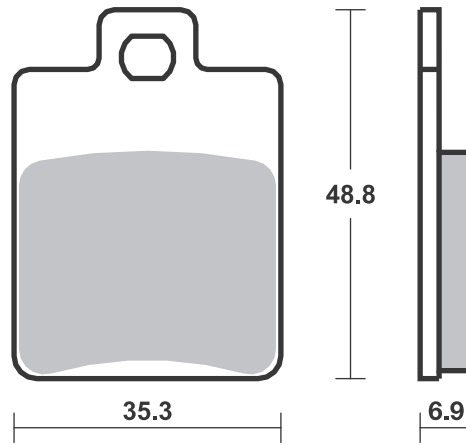

Available compounds

HF • CT

SBS 143

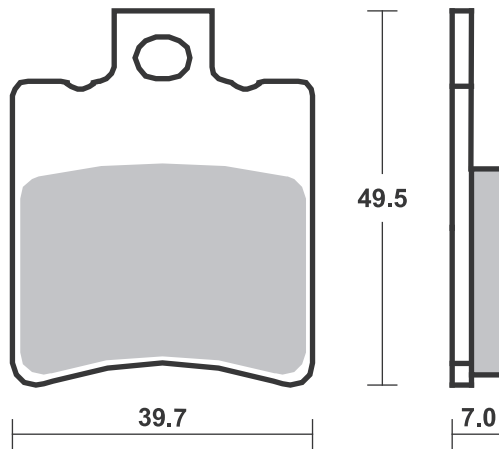





Available compounds

HF • CT

SBS 144

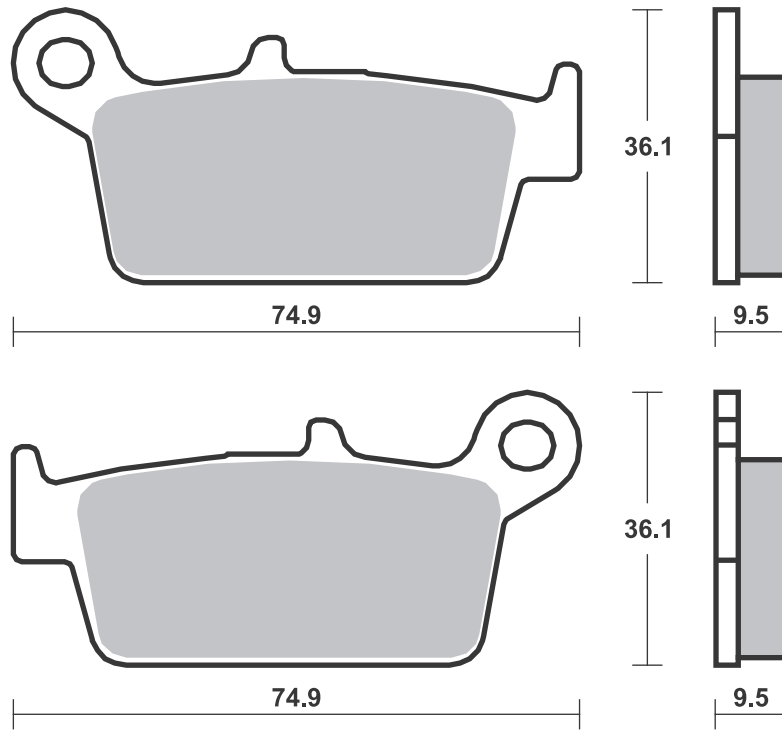

Available compounds

HF • CT • MS

SBS 145

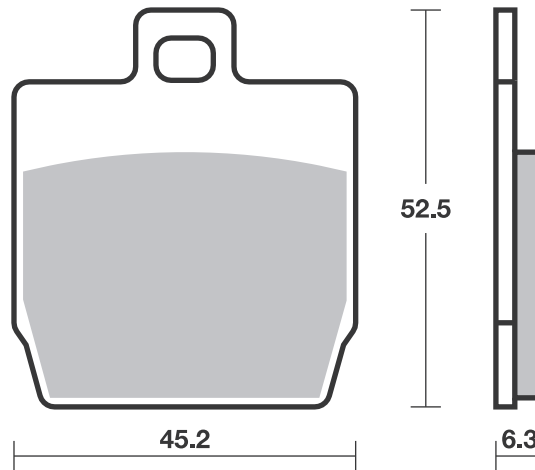

## Applications

### SBS 146 Recommended compound



#### KAWASAKI

SC	250 Epsilon	02-06	MS
----	-------------	-------	----

#### SUZUKI

AN	250 Burgman	98-06	MS
----	-------------	-------	----

AN	400 Burgman	99-06	MS
----	-------------	-------	----

#### SYM

	125 GTS	07-11	CT
--	---------	-------	----

	125 Joymax Sport	16-16	CT
--	------------------	-------	----

	250 GTS	07-11	MS
--	---------	-------	----

	250 Joymax Sport	16-17	MS
--	------------------	-------	----

	300 Joyride Evo i	10-10	MS
--	-------------------	-------	----

GTS	300 Evo i	11-15	MS
-----	-----------	-------	----

	500 GT	07-04	MS
--	--------	-------	----

### SBS 148 Recommended compound



#### DERBI

	50 Senda R DRD	03-04	HF
--	----------------	-------	----

GPR	50 R	98-03	HF
-----	------	-------	----

	125 Atmosphere	99-99	CT
--	----------------	-------	----

	180 Predator	99-99	CT
--	--------------	-------	----

#### HUSQVARNA

SM	50	02-02	HF
----	----	-------	----

#### ITALJET

SM	50	02-05	HF
----	----	-------	----

#### TOMOS

SE	50	05-06	HF
----	----	-------	----

### SBS 149 Recommended compound



#### APRILIA

SR	50 WWW, Netscaper	97-99	HF
----	----------------------	-------	----

Available compounds

HF • CT • MS

SBS 146

1 set = 4 pcs.

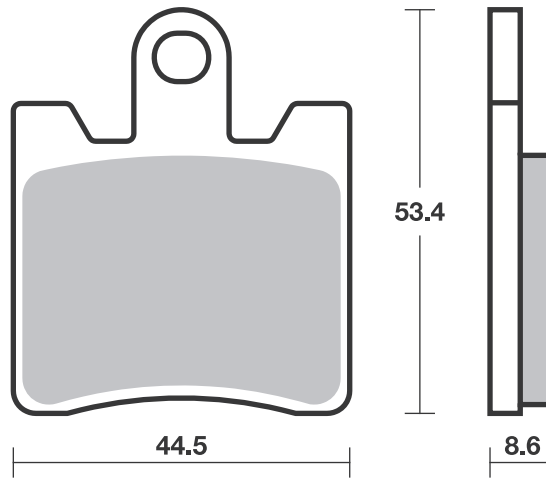

Available compounds

HF • CT

SBS 148

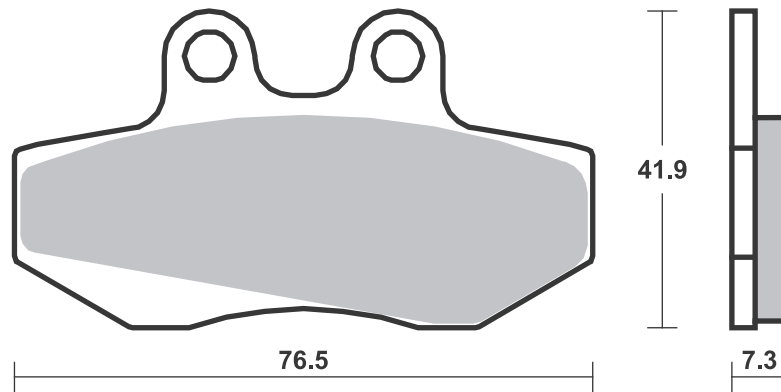

Available compounds

HF • CT

SBS 149

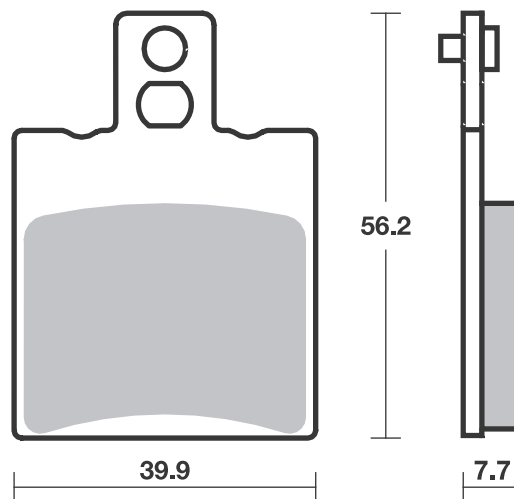

**SBS 150** Recommended compound



**SYM**

125 Husky	99-05	CT
150 Husky	99-02	CT

**SBS 151** Recommended compound



**ITALJET**

125 Dragster	20-20	CT
200 Dragster	20-20	CT

**YAMAHA**

XQ	125 Maxter	01-05	CT
YP	125 Majesty	01-11	CT
XQ	150 Maxter	01-02	CT
YP	150 Majesty	01-02	CT

Available compounds

HF • CT

SBS 150

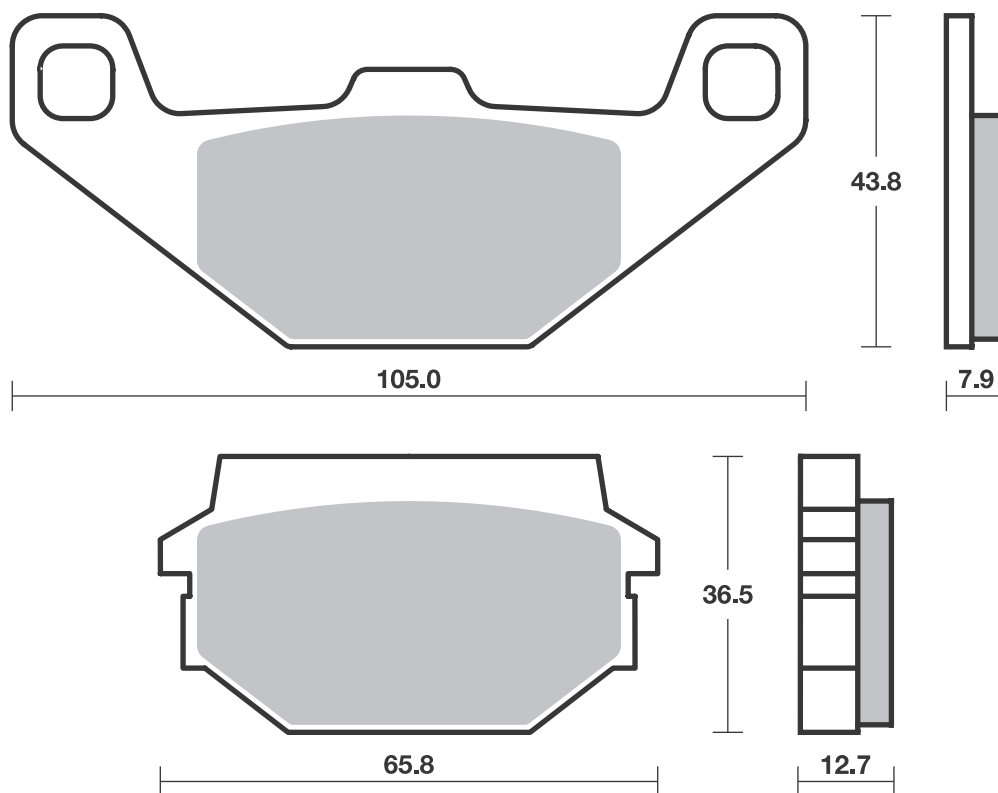

Available compounds

HF • CT • MS

SBS 151

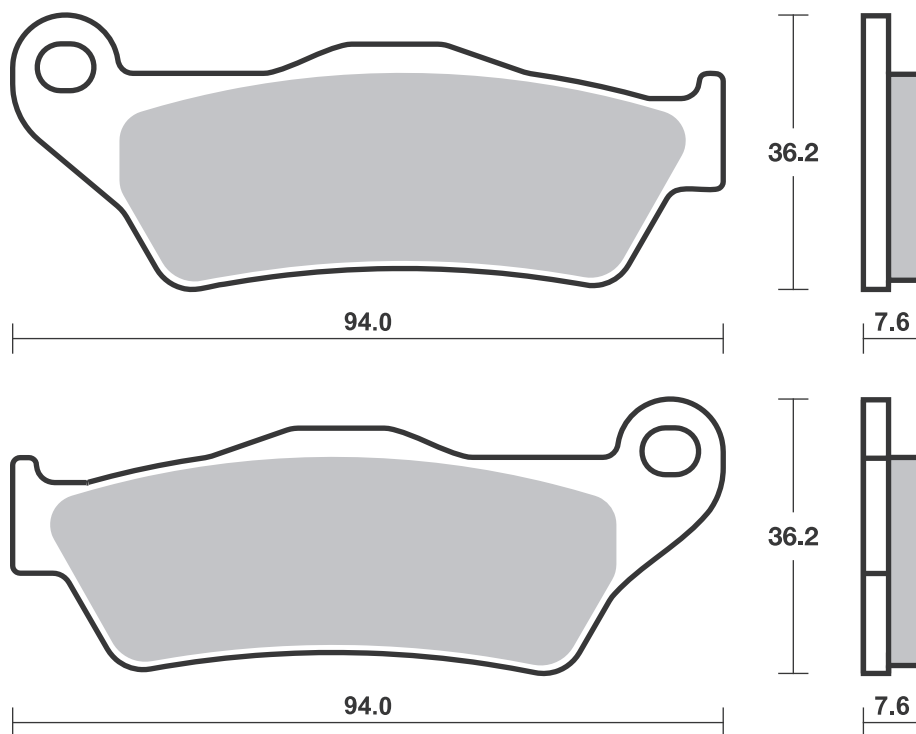

**SBS 152 Recommended compound**



<b>APRILIA</b>			
SR	50 Ditech	01 - 06	<b>HF</b>
SR	50 Racing	00 - 04	<b>HF</b>
SR	50 Street	05 - 12	<b>HF</b>
	200 Sportcity	04 - 08	<b>CT</b>

<b>DERBI</b>			
	125 Rambla	08 - 14	<b>CT</b>
	300 Rambla	08 - 12	<b>MS</b>

<b>MALAGUTI</b>			
R	125 Madison	99 - 09	<b>CT</b>
	250 Madison	99 - 04	<b>MS</b>

**SBS 153 Recommended compound**



<b>APRILIA</b>			
SR	125	99 - 03	<b>CT</b>
SR	150	00 - 03	<b>CT</b>

Brake Pad 1:1 Drawings, Compounds, Fitments

Available compounds

HF • CT • MS

SBS 152

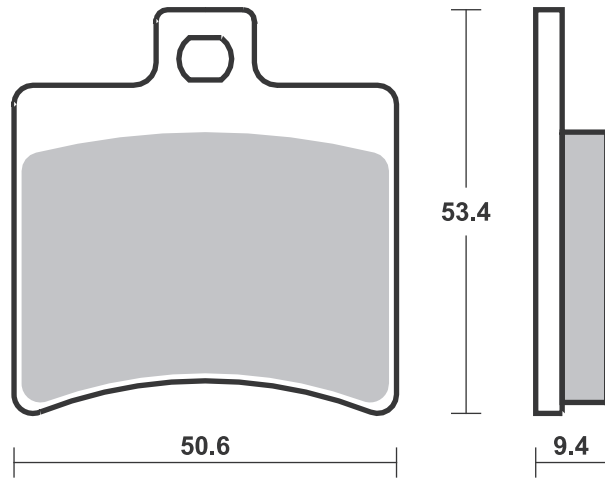

Available compounds

HF • CT • MS

SBS 153

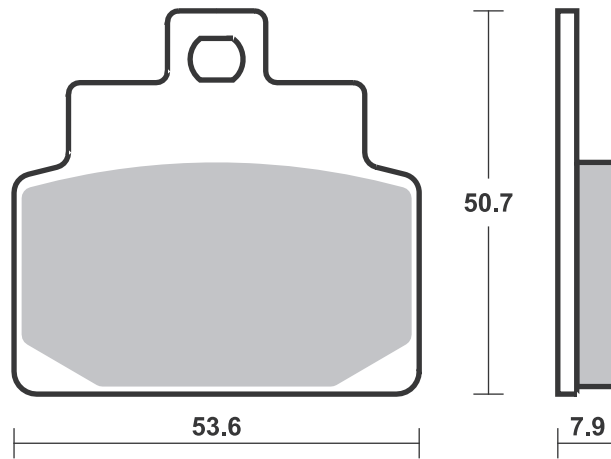

# Applications

## SBS 154 Recommended compound



<b>KYMCO</b>			
	50 Agility (4T) R16	06-15	<b>HF</b>
	50 People	99-06	<b>HF</b>
	50 Super-8	08-16	<b>HF</b>
	50 Super-9 L/C	02-07	<b>HF</b>
	125 Agility 16+	14-16	<b>CT</b>
	125 People	01-09	<b>CT</b>
	125 People One i	14-16	<b>CT</b>
	125 Super-8	08-15	<b>CT</b>
	125 Super-9	00-01	<b>CT</b>
S	125 People	05-08	<b>CT</b>
	150 People	01-06	<b>CT</b>
	200 Agility 16+	14-17	<b>CT</b>
	200 Agility R16	11-15	<b>CT</b>
S	200 People	05-07	<b>CT</b>
	250 Super-9	00-05	<b>CT</b>

<b>SYM</b>			
	125 Joyride	01-06	<b>CT</b>
HD	125	04-10	<b>CT</b>
	150 Joyride	01-06	<b>CT</b>
	200 Joyride	01-08	<b>CT</b>
HD	200	04-06	<b>CT</b>
	500 GT	07-04	<b>MS</b>

## SBS 155 Recommended compound



<b>YAMAHA</b>			
YP	125 XMAX ABS	11-16	<b>CT</b>
YP	125 XMAX Business ABS	11-13	<b>CT</b>
YP	250 D Majesty DX	98-00	<b>MS</b>
YP	250 Majesty DX/ABS	99-14	<b>MS</b>
YP	250 XMAX	05-13	<b>MS</b>

Brake Pad 1:1 Drawings, Compounds, Fitments



Available compounds

HF • CT • MS

SBS 154

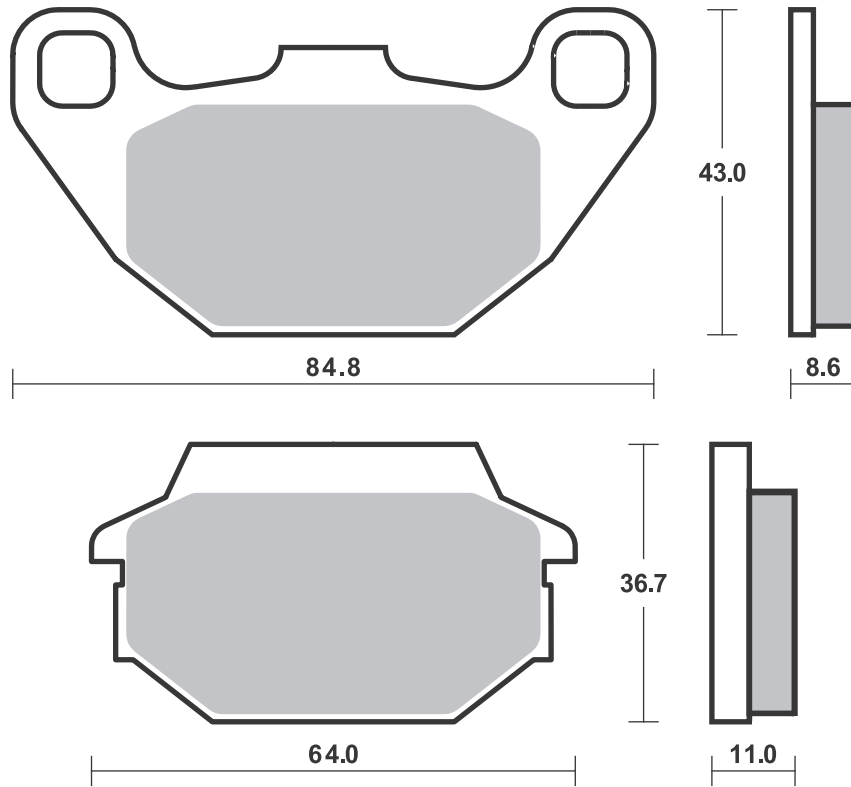

Available compounds

HF • CT • MS

SBS 155

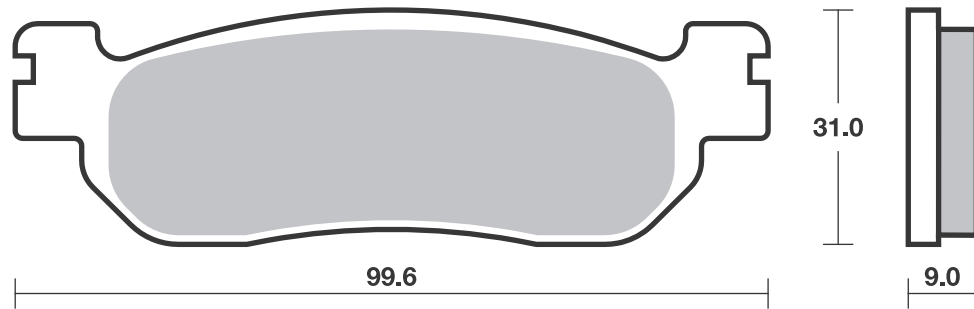

**SBS 156** Recommended compound

<b>HONDA</b>			
NSS	250 Reflex	01-07	<b>MS</b>
FJS	400 Silverwing	06-08	<b>MS</b>
FSC	600 Silverwing	01-08	<b>MS</b>
<b>PEUGEOT</b>			
	125 Looxor	03-07	<b>CT</b>

**SBS 157** Recommended compound

<b>CPI</b>			
	50 GTR	03-09	<b>HF</b>
	125 X-Large	02-03	<b>CT CT</b>
	200 X-Large	02-03	<b>CT CT</b>
<b>DERBI</b>			
	50 Senda DRD		
	Pro SM	05-11	<b>HF</b>
	125 Senda DRD SM	10-14	<b>HF</b>
<b>ITALJET</b>			
	125 Dragster	20-20	<b>CT</b>
	200 Dragster	20-20	<b>CT</b>
<b>PEUGEOT</b>			
	50 Speedfight 3		
	(LC)	10-16	<b>HF</b>
	50 Speedfight 3 RS		
	(LC)	10-16	<b>HF</b>
	50 Speedfight 4		
	(LC)	15-16	<b>HF</b>
<b>YAMAHA</b>			
XQ	125 Maxter	01-05	<b>CT</b>
YP	125 Majesty	01-11	<b>CT</b>
YP	125 XMAX	06-18	<b>CT</b>
YP	125 XMAX Sport Ed.	11-13	<b>CT</b>
XQ	150 Maxter	01-02	<b>CT</b>
YP	150 Majesty	01-02	<b>CT</b>

Available compounds

HF • CT • MS

SBS 156

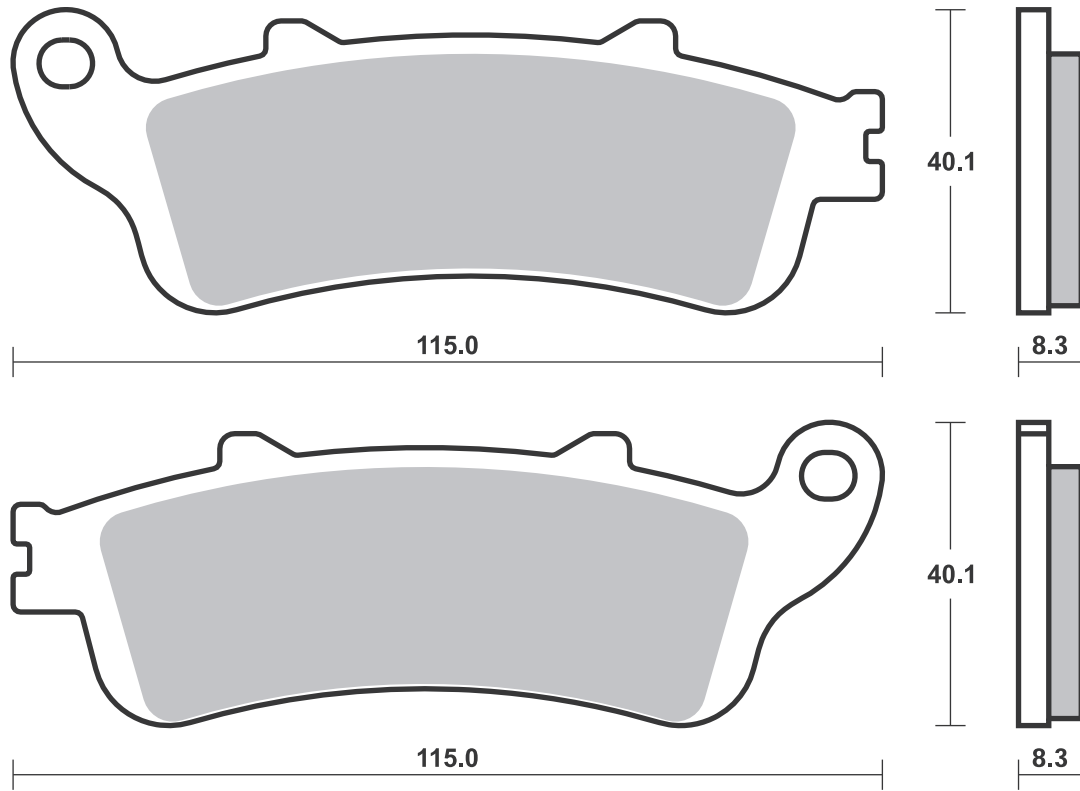

Available compounds

HF • CT • MS

SBS 157

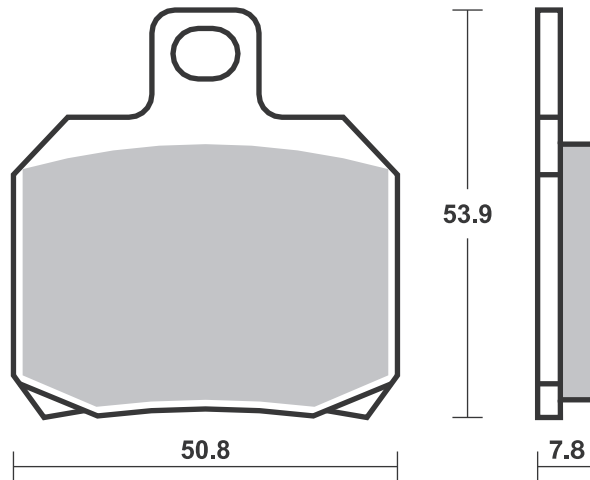

**SBS 158** Recommended compound



HONDA			
NSS	250 Reflex	01-07	<b>MS</b>

**SBS 159** Recommended compound



KYMCO			
	125 Dink X	22-22	<b>CT</b>
	125 New Downtown	16-17	<b>CT</b>
	125 People GTi	12-15	<b>CT</b>
	125 X-Town CT	20-20	<b>CT</b>
DT	125 X360	22-22	<b>CT</b>
	200 People GTi	12-15	<b>CT</b>
	300 People GTi	12-15	<b>MS</b>
	300 People S	20-20	<b>MS</b>
	300 X-Town CT	20-20	<b>MS</b>
	350 New Downtown	16-17	<b>MS</b>

MALAGUTI			
	250 Madison	99-04	<b>MS</b>

Brake Pad 1:1 Drawings, Compounds, Fitments

Available compounds

HF • CT • MS

SBS 158

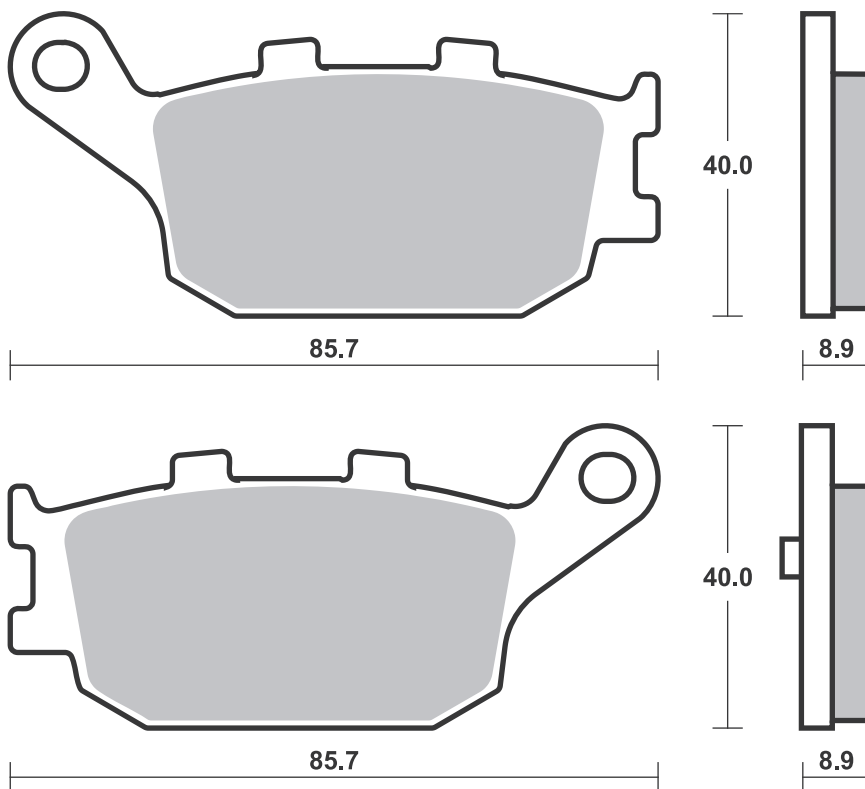

Available compounds

HF • CT • MS

SBS 159

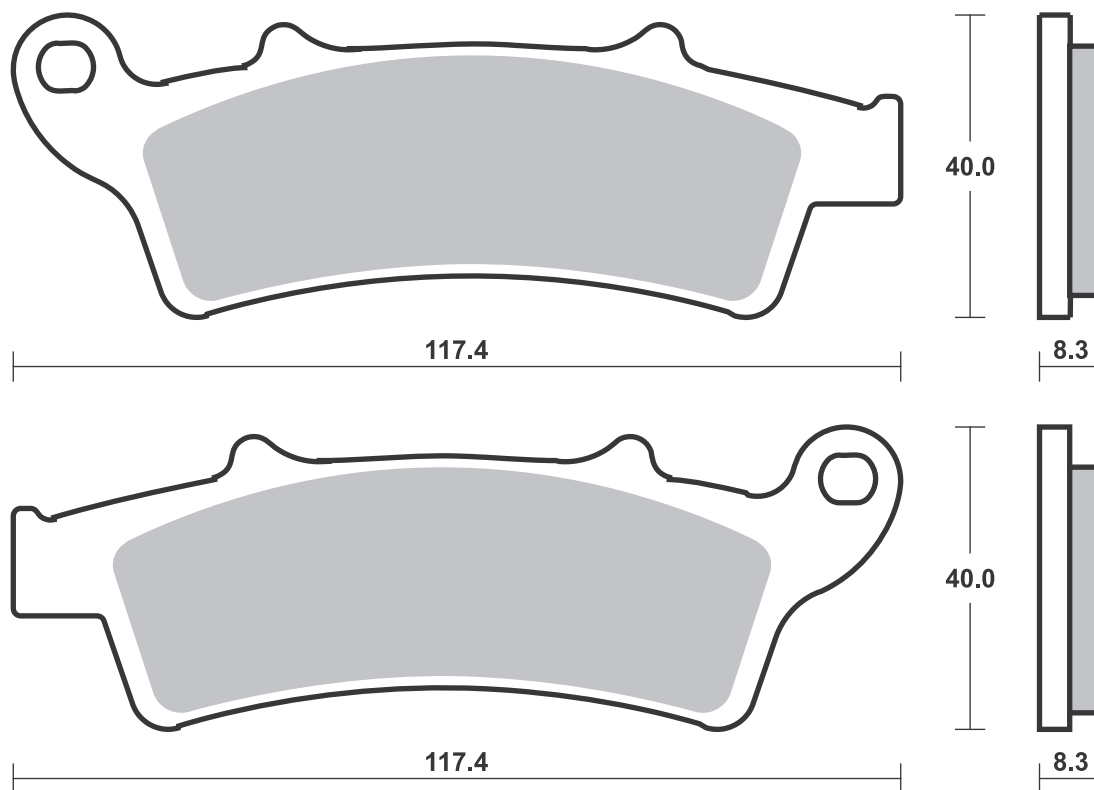



Available compounds

HF • CT

SBS 160

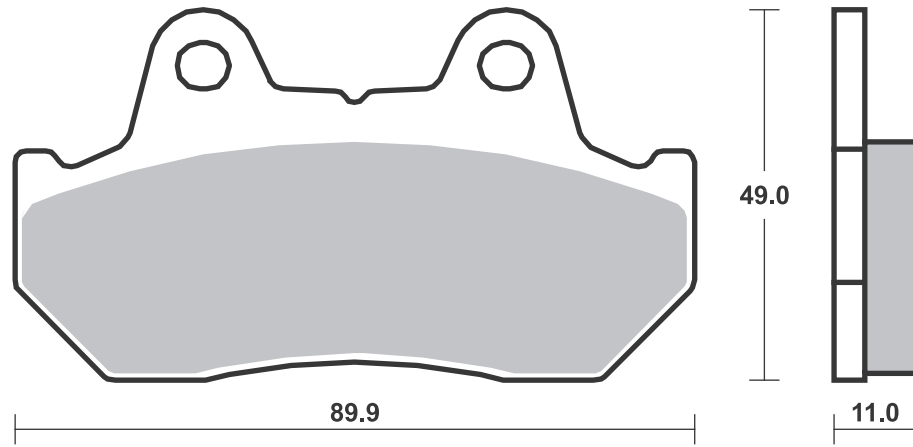

Available compounds

HF • CT

SBS 163

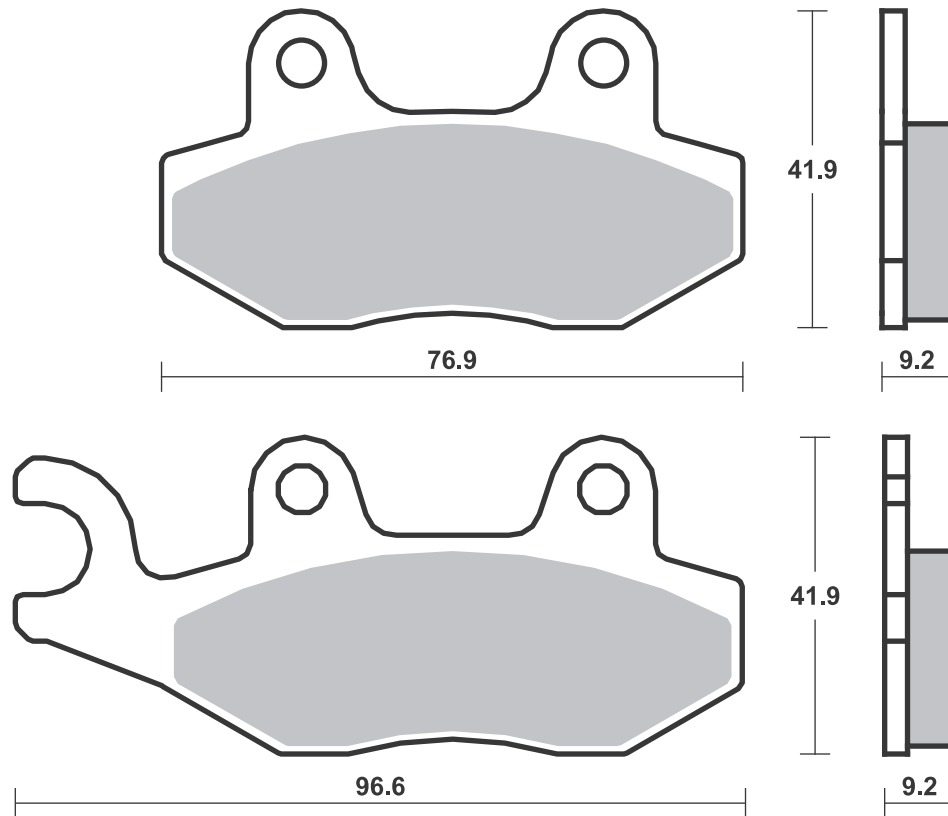





Available compounds

HF • CT

SBS 165

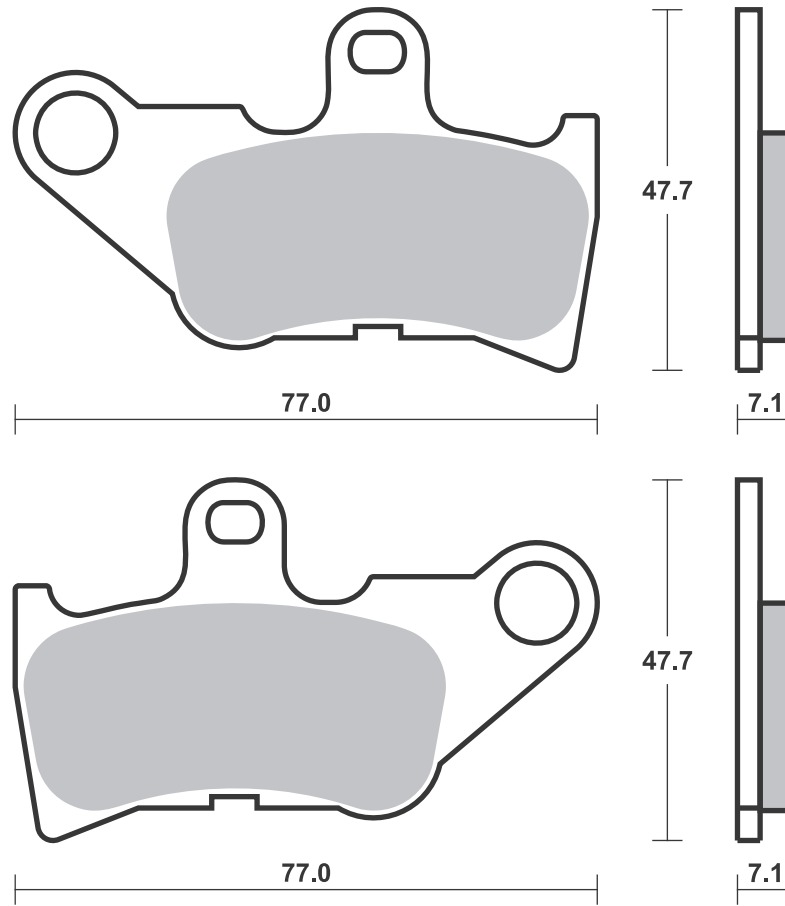

Available compounds

HF • CT

SBS 167

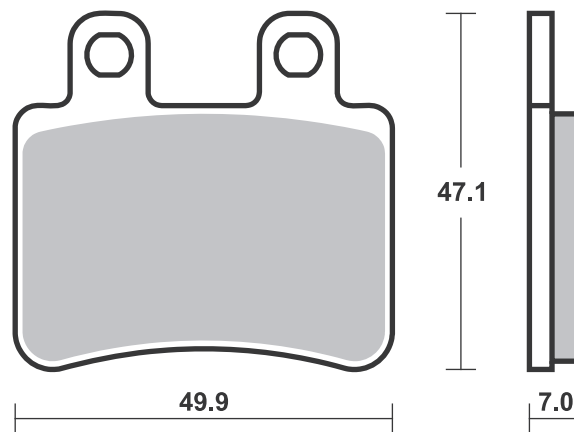



<b>DERBI</b>			
50 Black Devil	04-04		<b>HF</b>
50 DRD Racing R	05-10		<b>HF</b>
50 DRD Racing R			
Ltd.	05-05		<b>HF</b>
50 DRD Racing SM	05-05		<b>HF</b>
50 DRD Racing SM			
Ltd.	05-05		<b>HF</b>
50 Senda SM DRD			
Black Edition	03-04		<b>HF</b>
125 Senda Baja	06-12		<b>HF</b>

<b>PEUGEOT</b>			
125 Elyseo	00-07		<b>CT</b>
125 Elystar	03-07		<b>CT</b>
150 Elyseo	00-04		<b>CT</b>
150 Elystar	03-04		<b>CT</b>

<b>YAMAHA</b>			
TZR	50	03-04	<b>HF</b>



<b>YAMAHA</b>			
250 Morphus	06-06		<b>MS</b>
XP 500 TMAX	01-03		<b>MS</b>
XP 530 TMAX	12-19		<b>MS</b>
XP 530 TMAX DX	17-19		<b>MS</b>
XP 530 TMAX Iron Max	15-19		<b>MS</b>
XP 530 TMAX SX	17-19		<b>MS</b>
560 TMAX	20-20		<b>MS</b>
560 TMAX Tech Max	20-20		<b>MS</b>

Brake Pad 1:1 Drawings, Compounds, Fitments

Available compounds

HF • CT

SBS 168

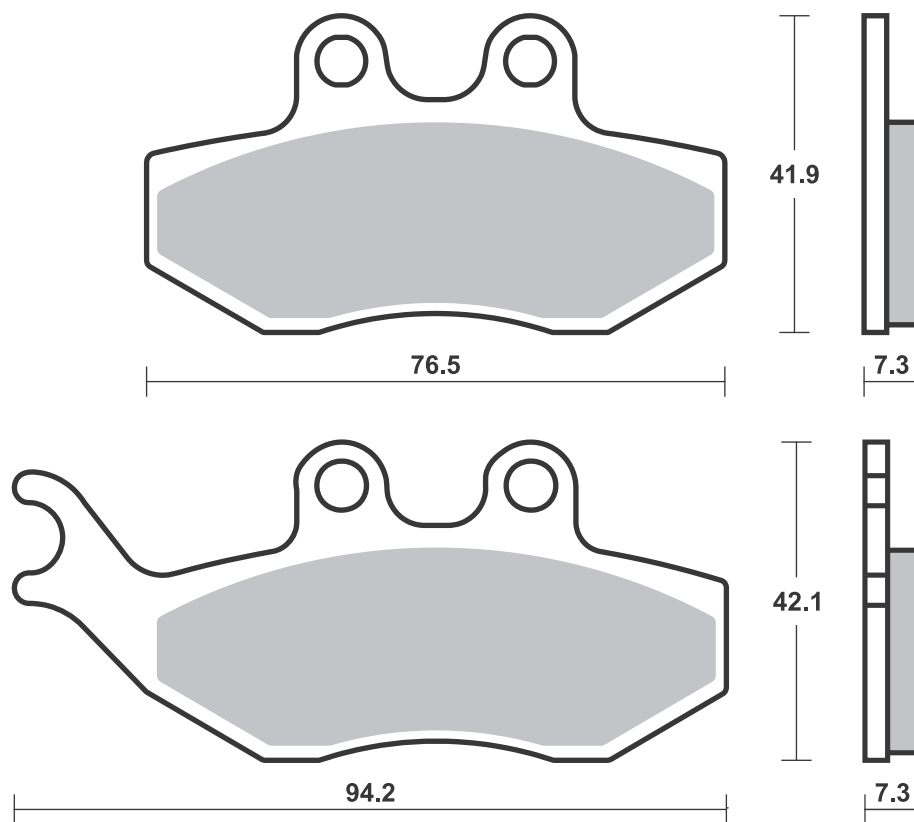

Available compounds

HF • CT • MS

SBS 169

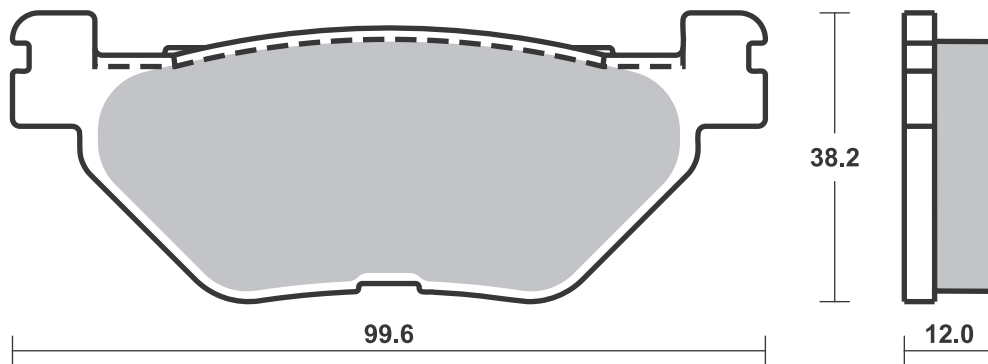

## Applications

### SBS 170 Recommended compound



#### YAMAHA

	250 Morphus	06-06	<b>MS</b>
YP	400 Majesty	04-04	<b>MS</b>
XP	500 TMAX	01-03	<b>MS</b>

### SBS 171 Recommended compound



#### SYM

	125 Voyager	05-05	<b>CT</b>
	250 Joymax	07-10	<b>MS</b>
	250 Voyager	05-05	<b>MS</b>
RV	250 Efi	10-10	<b>MS</b>
	300 Joymax Evo	10-12	<b>MS</b>
	300 Joymax Sport	16-17	<b>MS</b>
GTS	300	09-13	<b>MS</b>

Available compounds

HF • CT • MS

SBS 170

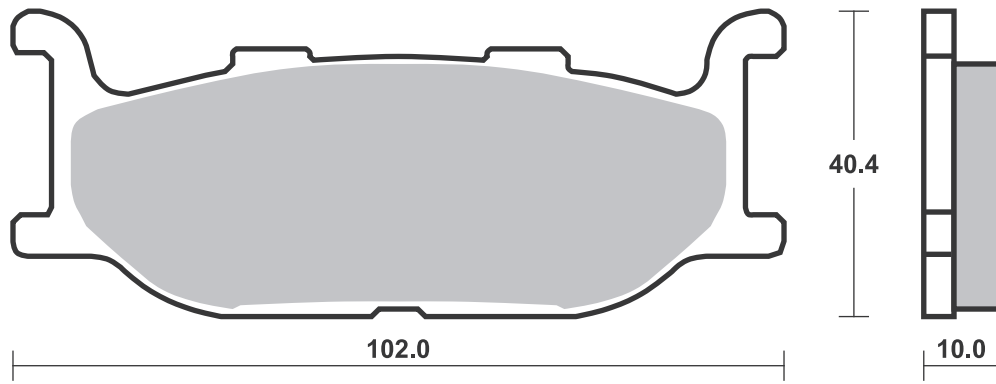

Available compounds

HF • CT • MS

SBS 171

1 set = 4 pcs.

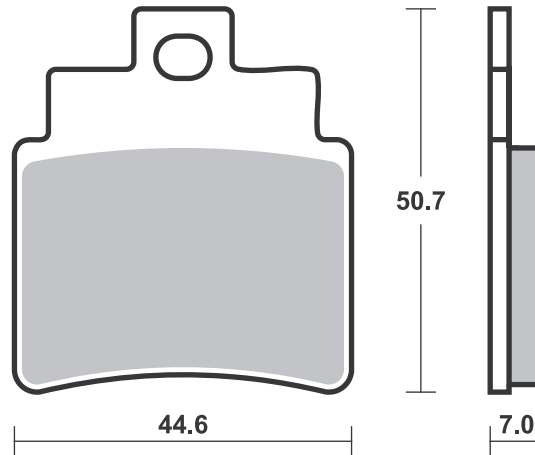

**SBS 173** Recommended compound



<b>ITALJET</b>			
	250 Jupiter	01-03	<b>CT</b>

<b>KEEWAY</b>			
TX	50 SM	10-12	<b>HF</b>

**SBS 174** Recommended compound



<b>KAWASAKI</b>			
SC	250 Epsilon	02-06	<b>MS</b>

<b>SUZUKI</b>			
AN	250 Burgman	04-06	<b>MS</b>
AN	400 Burgman	01-06	<b>MS</b>

Available compounds

HF • CT

SBS 173

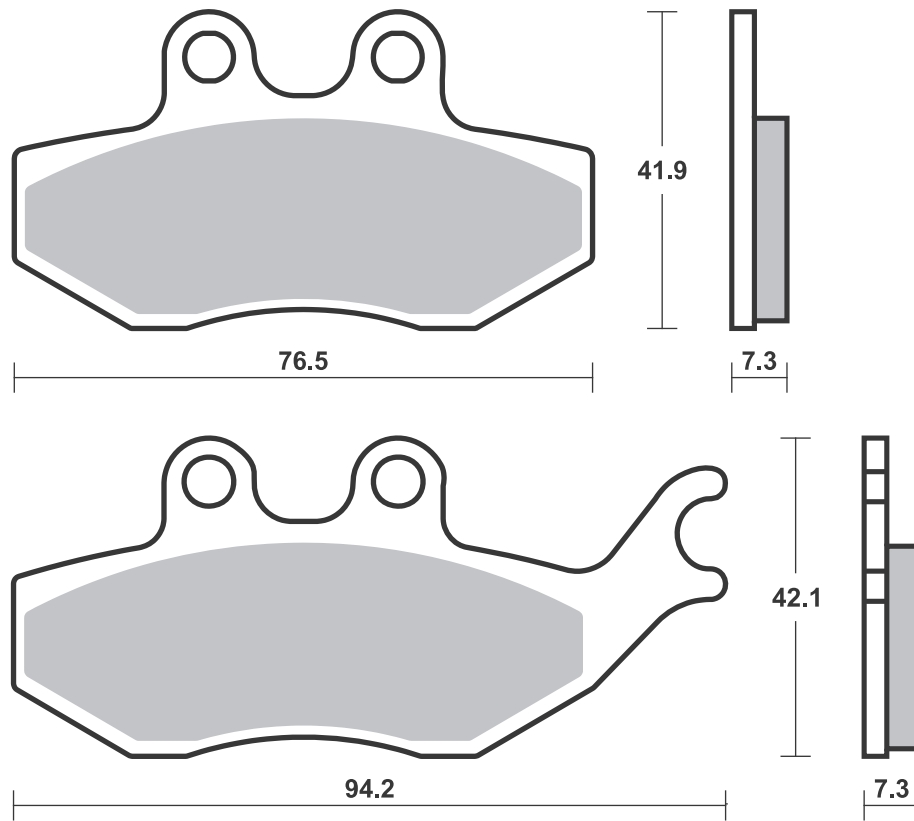

Available compounds

HF • CT • MS

SBS 174

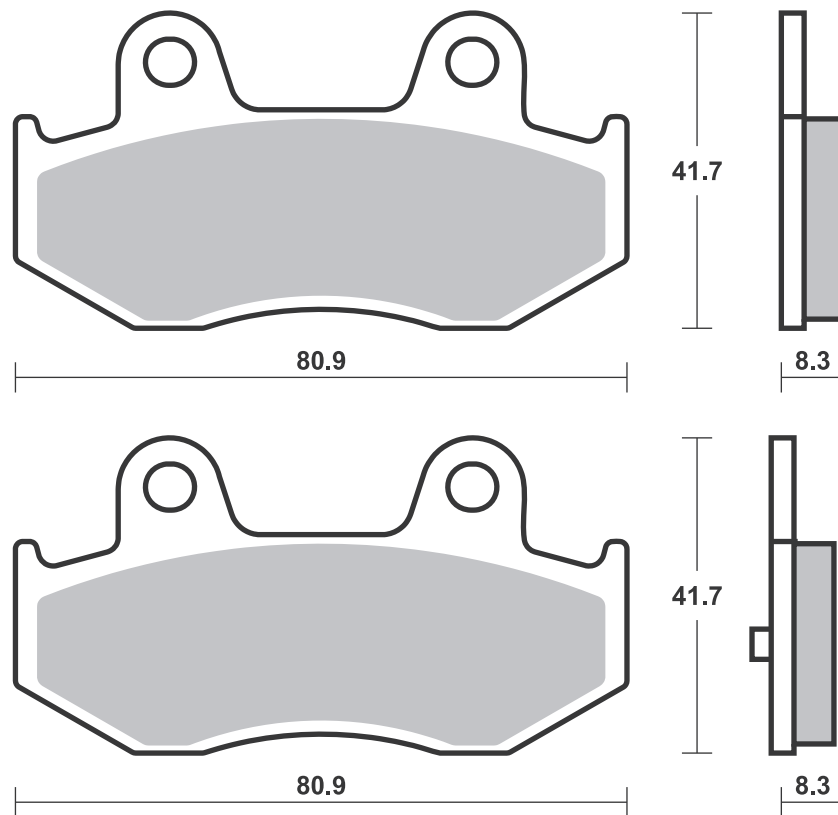

**SBS 175** Recommended compound



<b>BMW</b>			
C1	125	00-03	<b>CT</b>
C1	200	02-04	<b>CT</b>
C	400 X	18-21	<b>MS</b>

<b>YAMAHA</b>			
XC	155 S-Max	15-18	<b>CT</b>

**SBS 176** Recommended compound



<b>BMW</b>			
C1	125	00-03	<b>CT</b>
C1	200	02-04	<b>CT</b>



Available compounds

HF • CT • MS

SBS 175

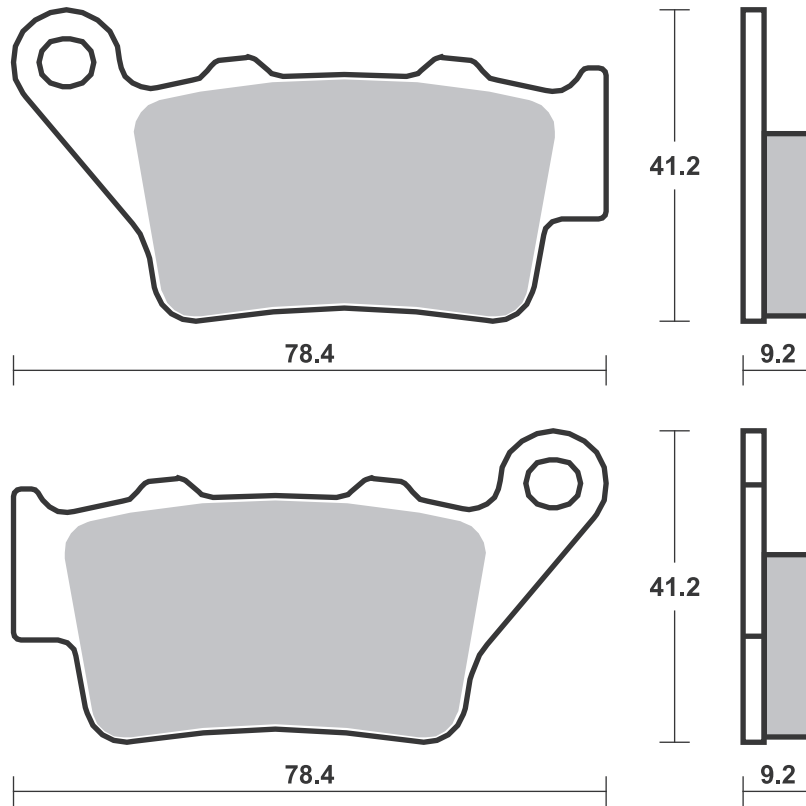

Available compounds

HF • CT • MS

SBS 176

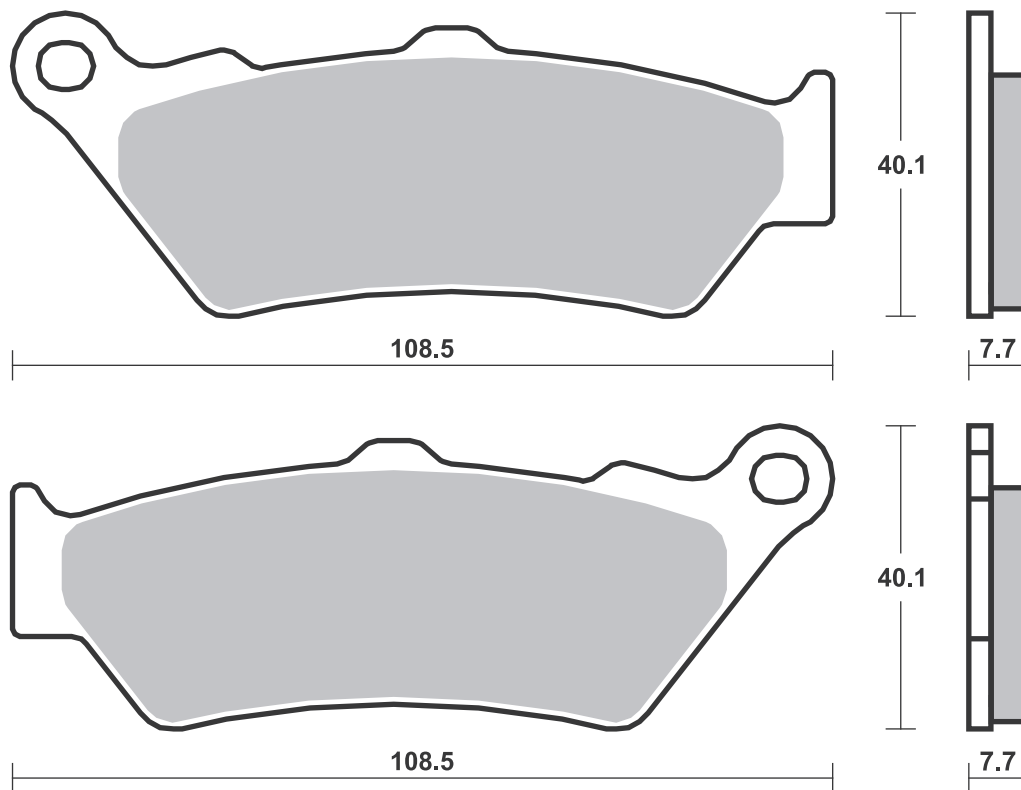



Available compounds

HF • CT • MS

SBS 177

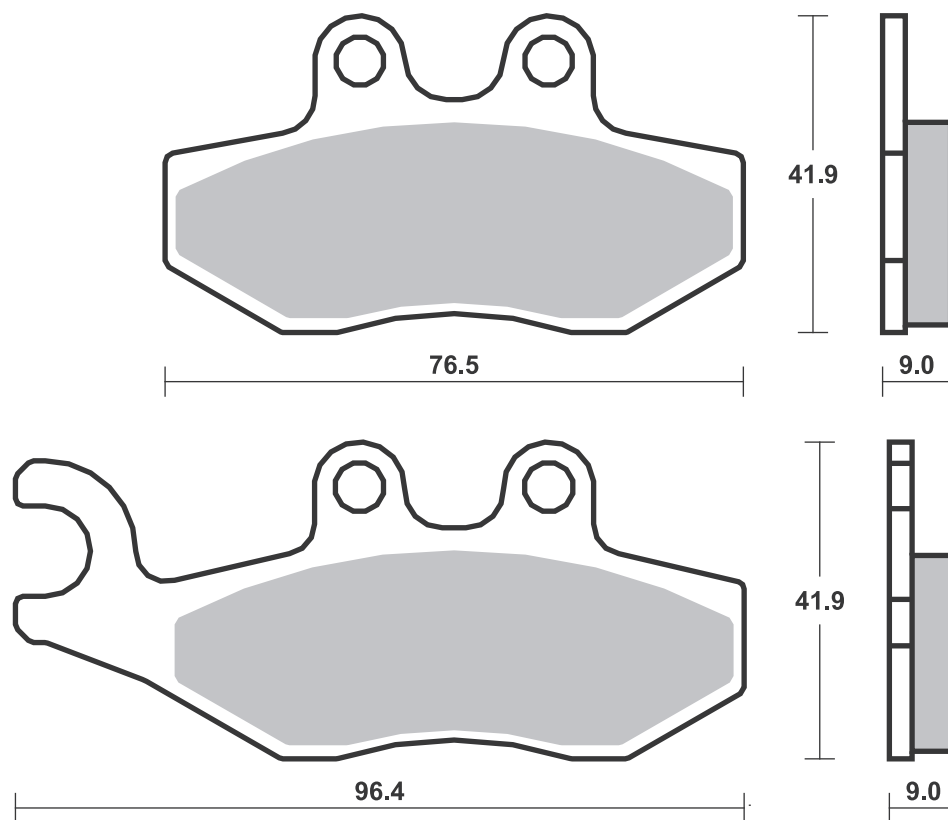

Available compounds

HF • CT

SBS 178

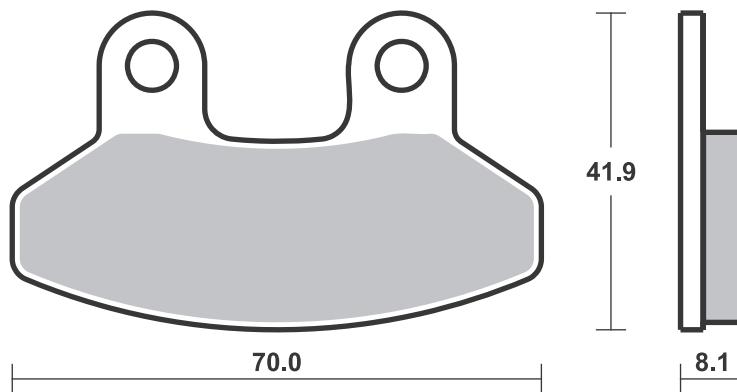



Available compounds

HF • CT

SBS 180

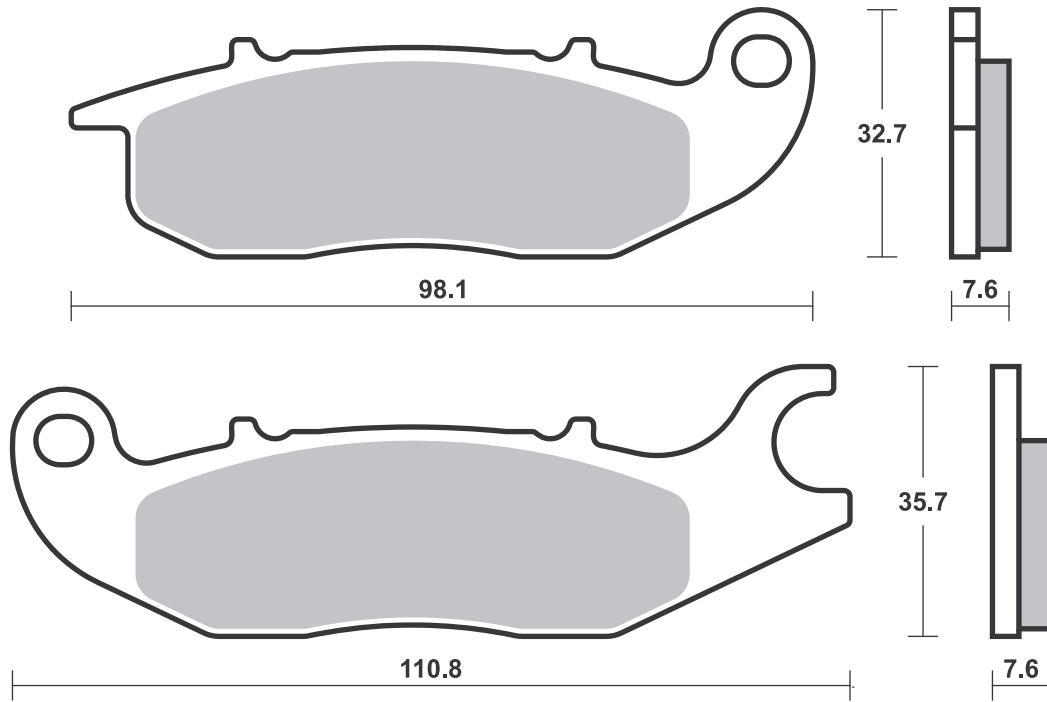

Available compounds

HF • CT • MS

SBS 181

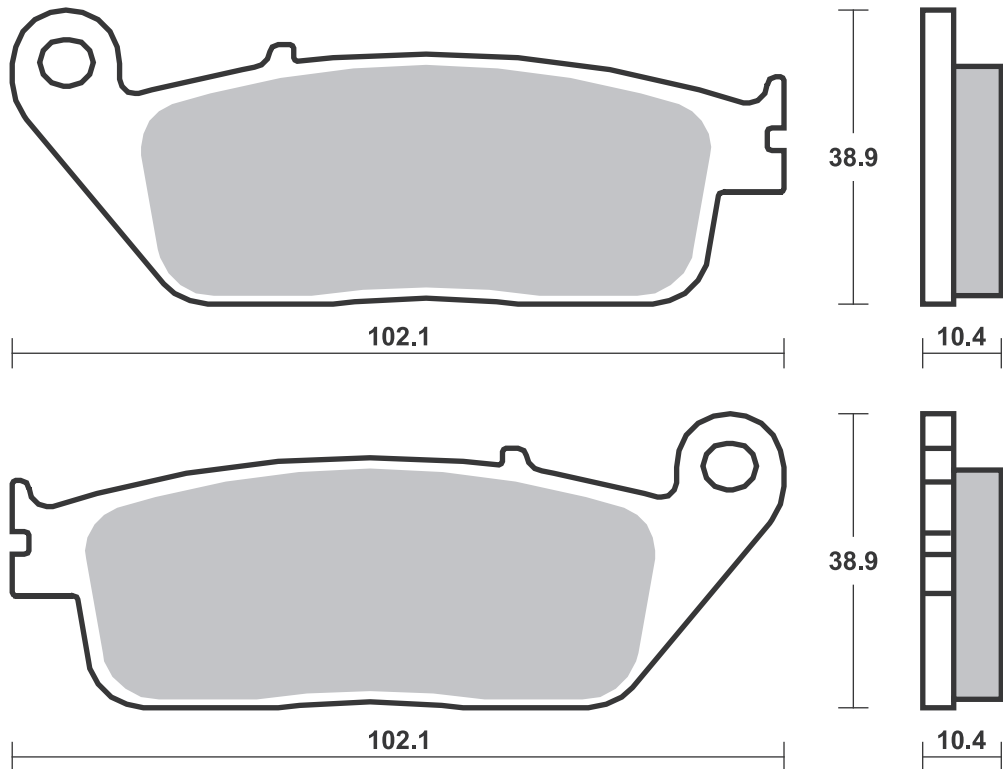



Available compounds

HF • CT • MS

SBS 182

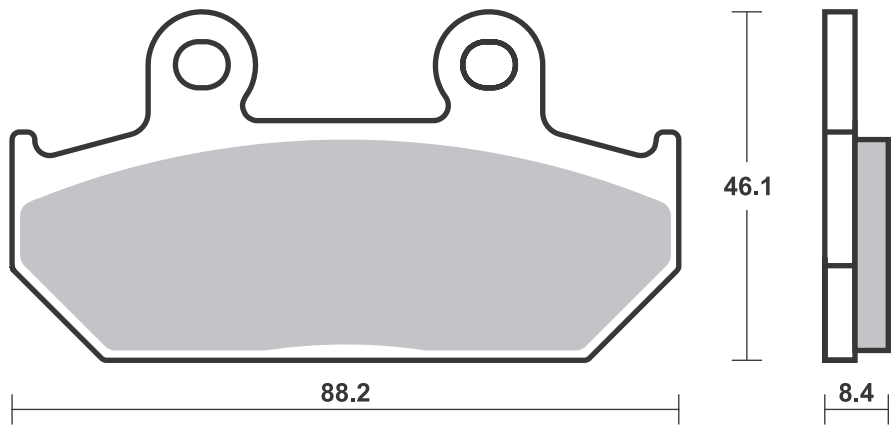
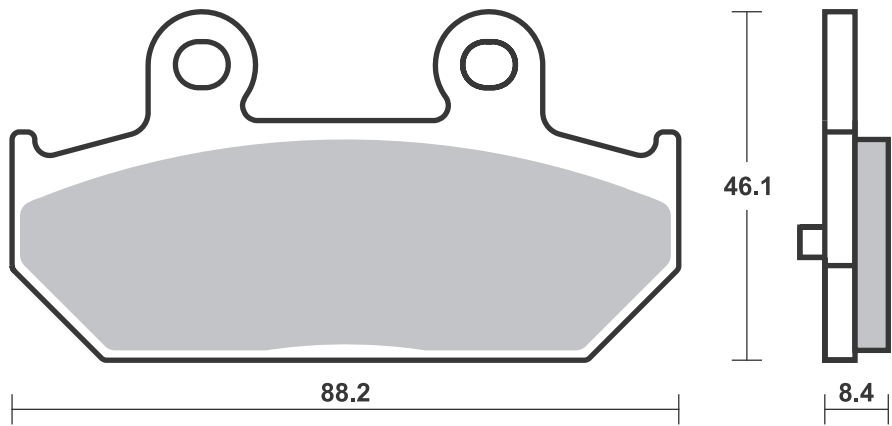

Available compounds

HF • CT • MS

SBS 183

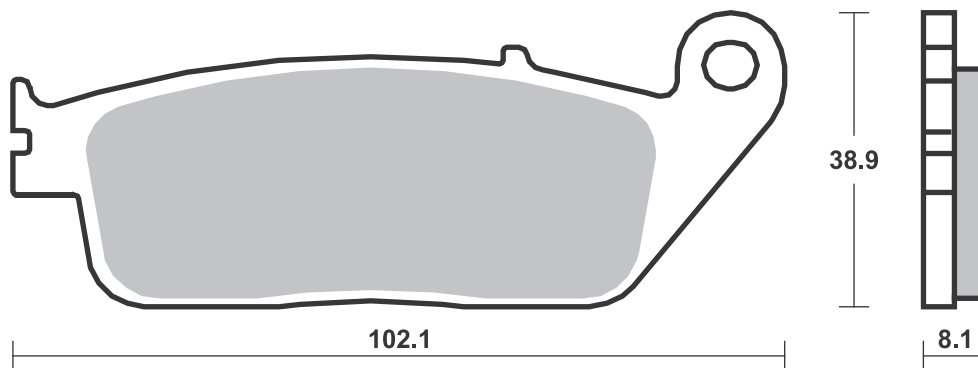
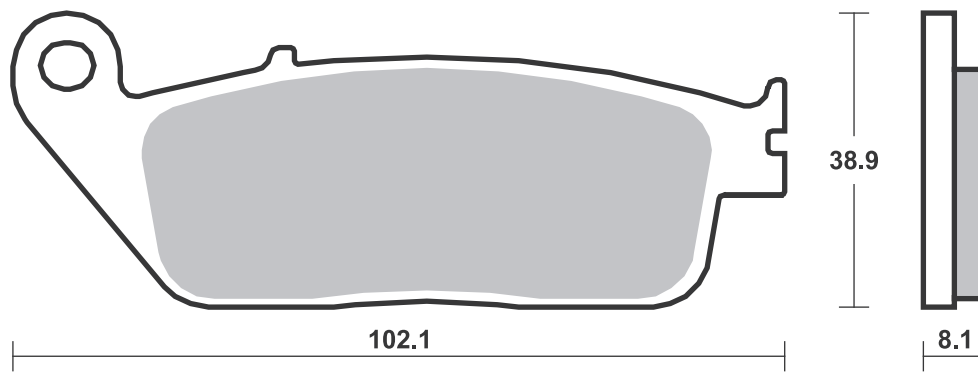





Available compounds

MS

SBS 184

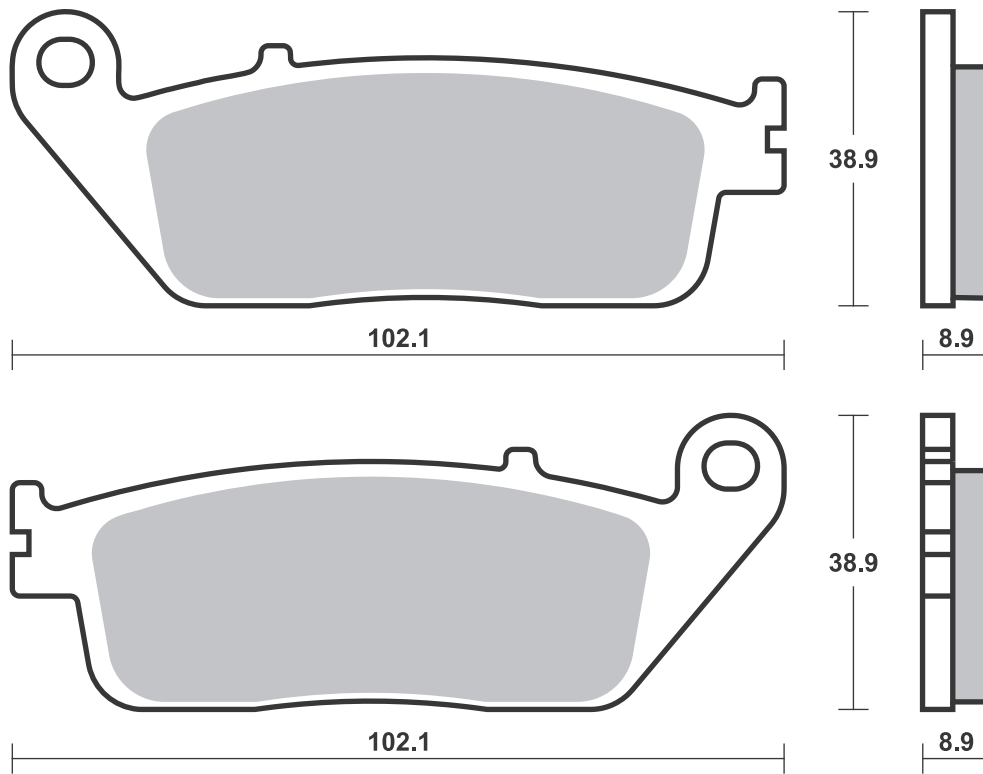

Available compounds

HF • CT • MS

SBS 185

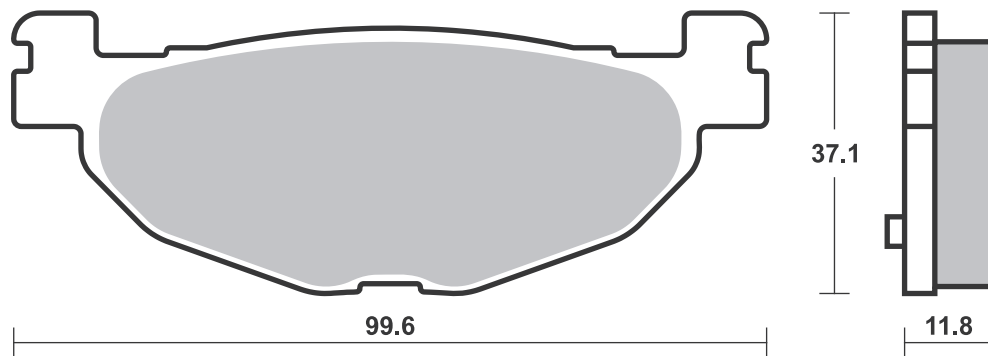



Available compounds

HF • CT • MS

SBS 187

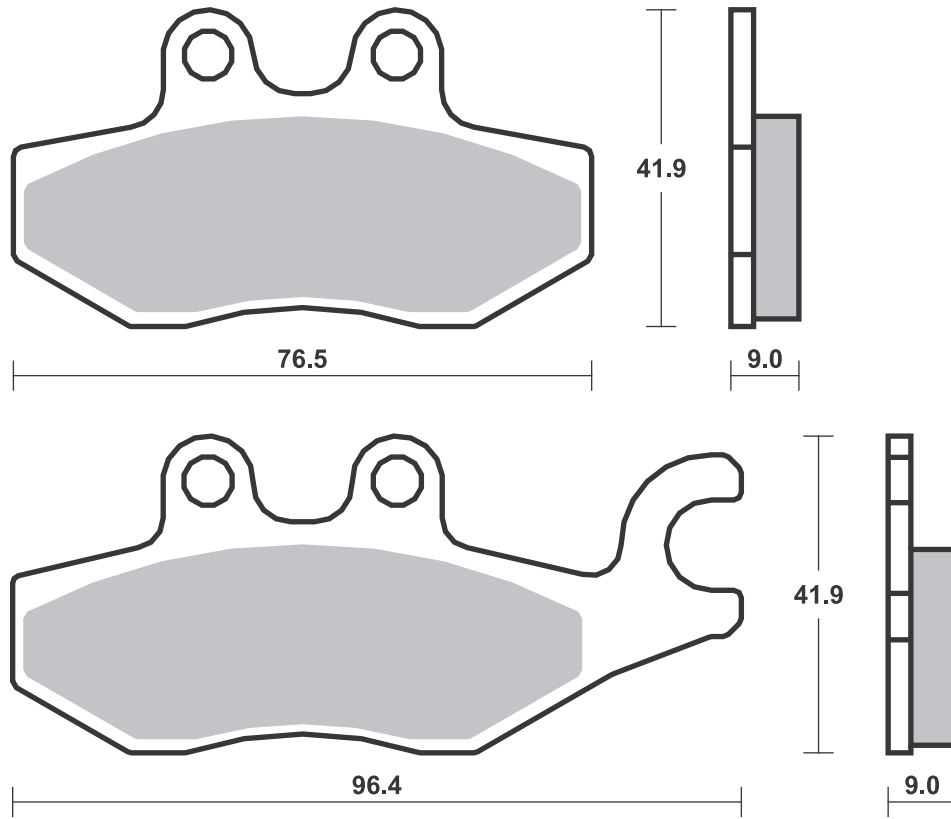

Available compounds

HF

SBS 188

If required without springs -  
 see SBS 105

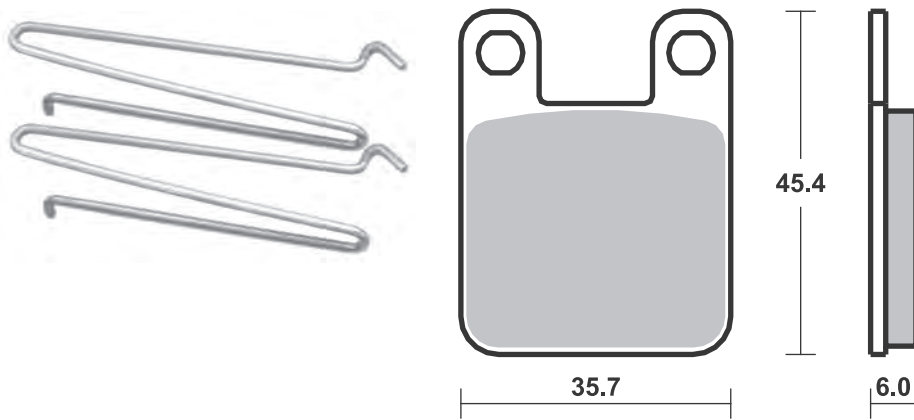



Available compounds

MS

SBS 189

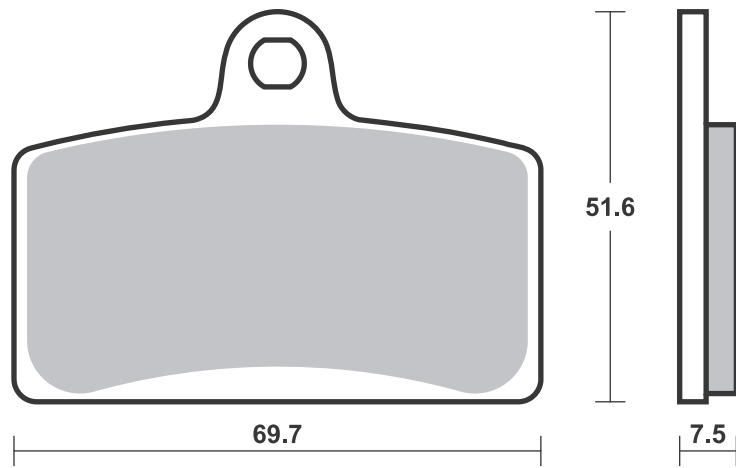

Available compounds

HF • CT • MS

SBS 190

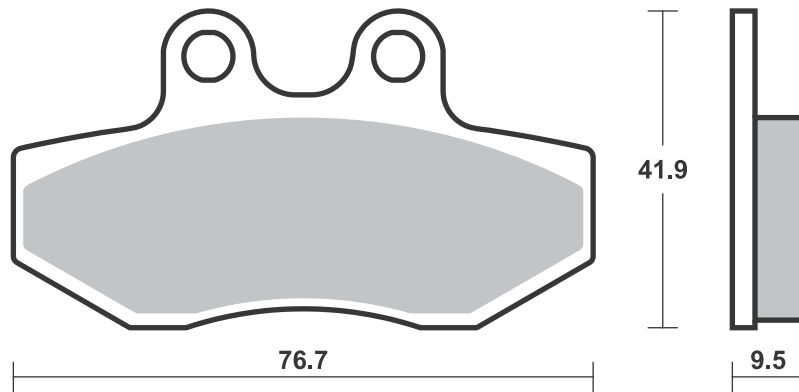

Available compounds

HF • CT • MS

SBS 191

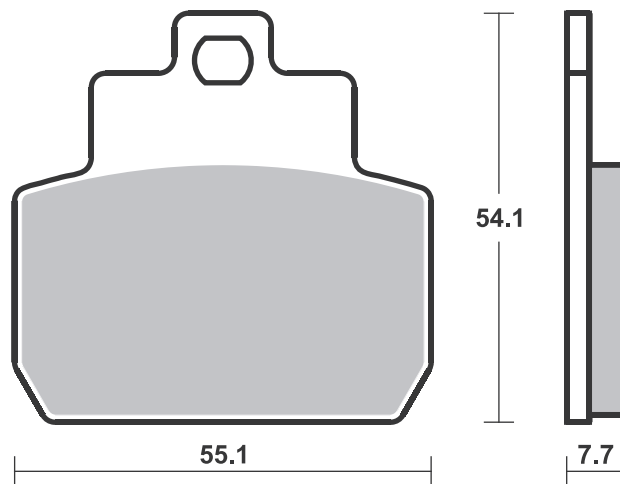

**SBS 192** Recommended compound



<b>HONDA</b>			
SH	125 i	09-12	<b>HF</b>
SH	150 i	09-12	<b>HF</b>
PS	250	05-06	<b>MS</b>
SH	300 i	07-19	<b>MS</b>
SW-T	400	09-13	<b>MS</b>
SW-T	400 ABS	09-14	<b>MS</b>
FSC	600 Silverwing	09-18	<b>MS</b>
SW-T	600	11-13	<b>MS</b>

<b>SUZUKI</b>			
UH	125 Burgman	07-14	<b>CT</b>
UH	200	07-07	<b>CT</b>
UH	200 Burgman	07-13	<b>CT</b>

**SBS 193** Recommended compound



<b>HONDA</b>			
NSS	125 Forza	15-19	<b>CT</b>
SH	125	13-20	<b>HF</b>
SH	125 i	09-12	<b>HF</b>
SH	150	13-18	<b>HF</b>
SH	150 i	09-12	<b>HF</b>
SH	300 i	07-19	<b>MS</b>
SH	300 i SH30	15-18	<b>MS</b>
ADV	350	22-22	<b>MS</b>

Available compounds

HF • CT • MS

SBS 192

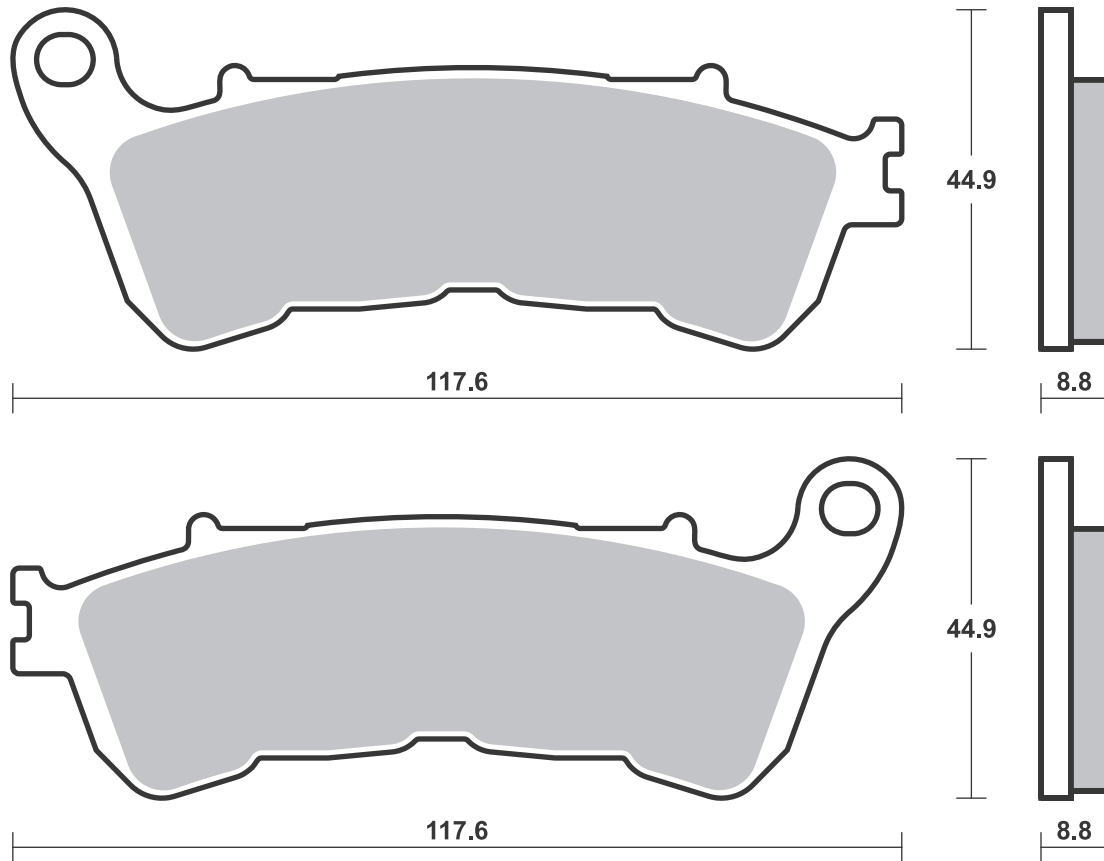

Available compounds

HF • CT • MS

SBS 193

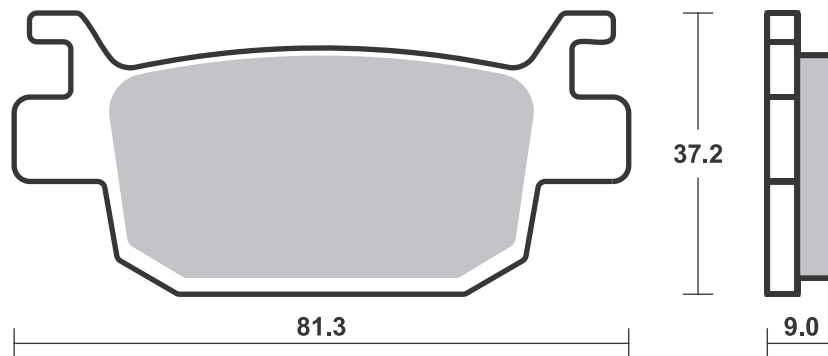





Available compounds

HF • CT • MS

SBS 194

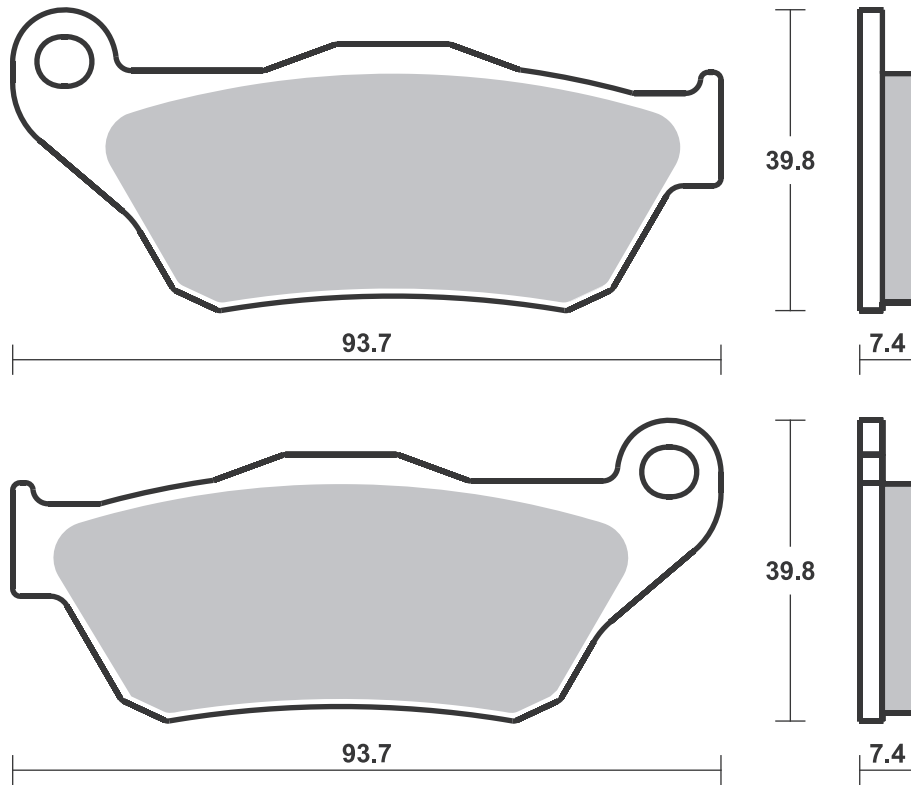

Available compounds

HF • CT • MS

SBS 195

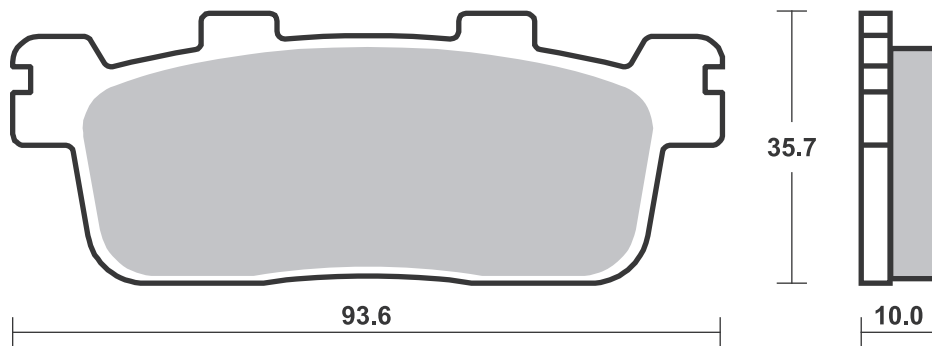



Available compounds

HF • CT • MS

SBS 196

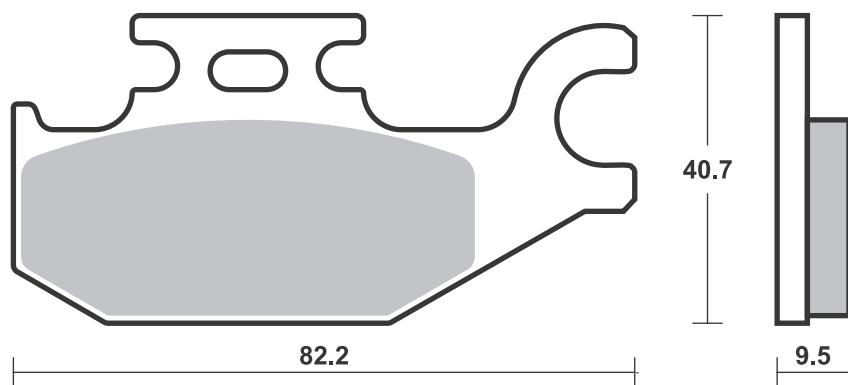
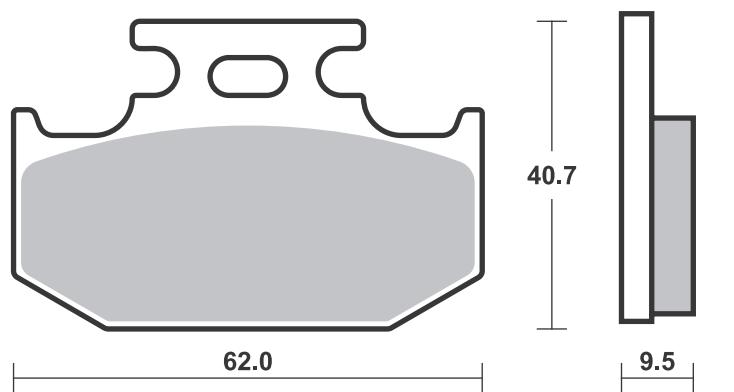

Available compounds

HF • CT • MS

SBS 197

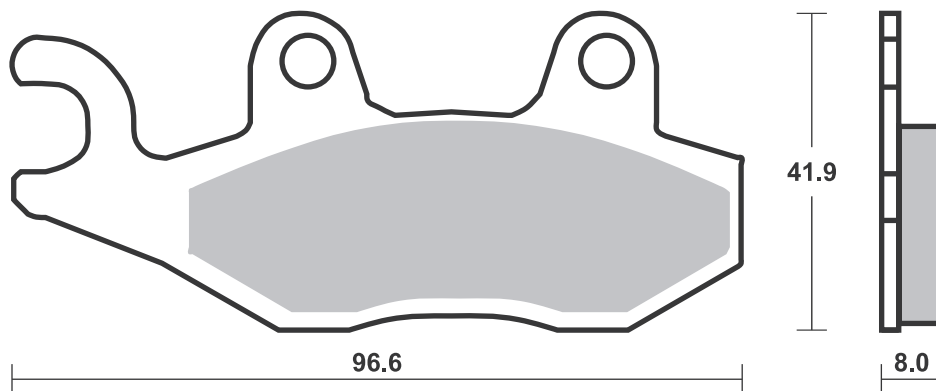
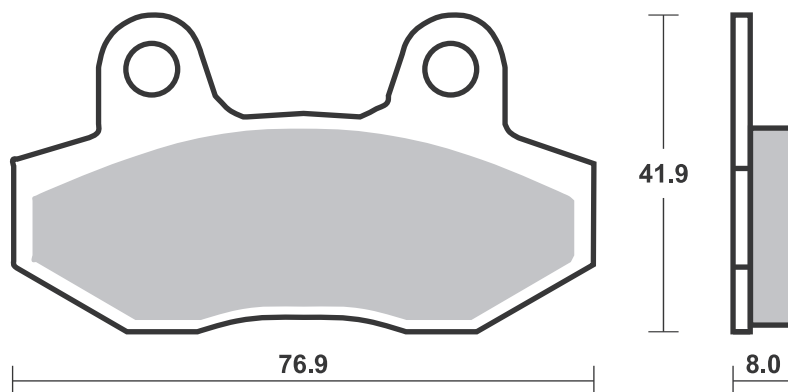



Available compounds

HF • CT • MS

SBS 198

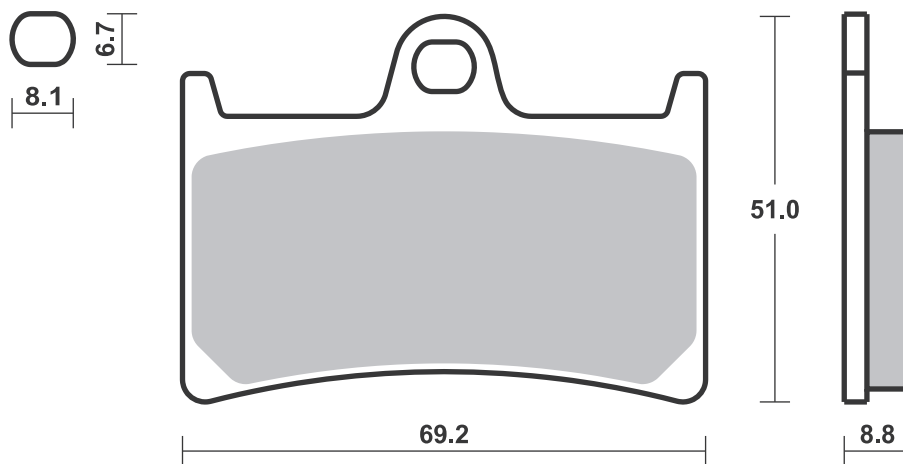

Available compounds

HF • CT

SBS 200

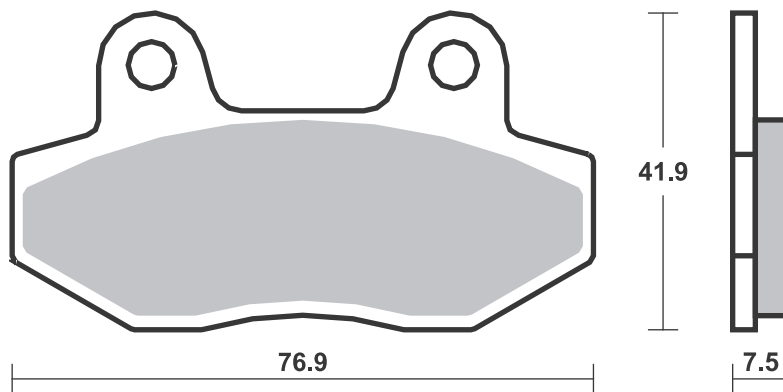

Available compounds

HF • CT • MS

SBS 201

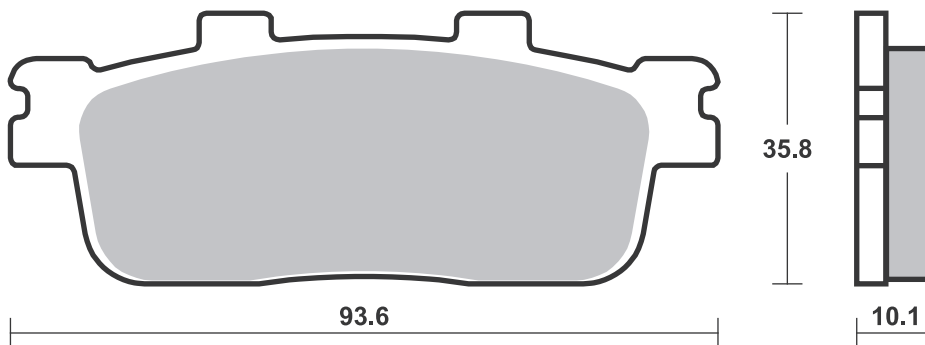



Available compounds

HF • CT • MS

SBS 202

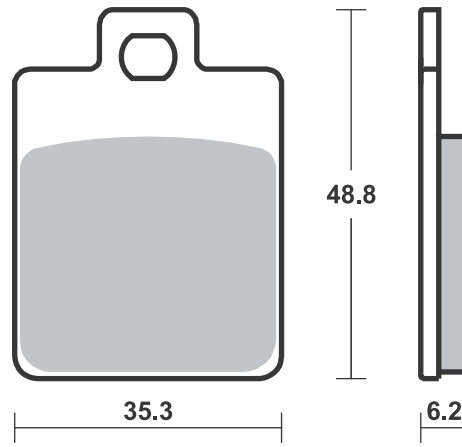

Available compounds

HF • CT

SBS 203

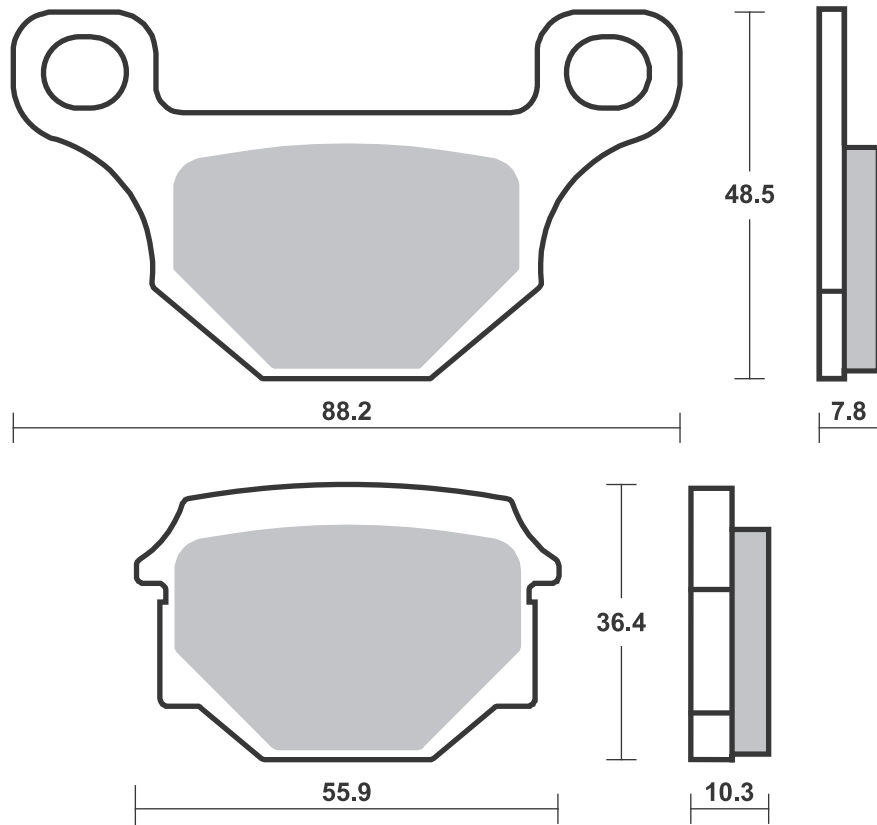





Available compounds

HF • CT • MS

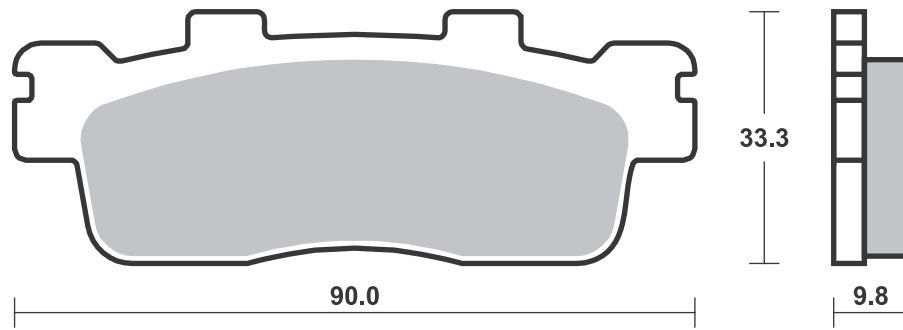

Available compounds

HF • CT • MS

SBS 205

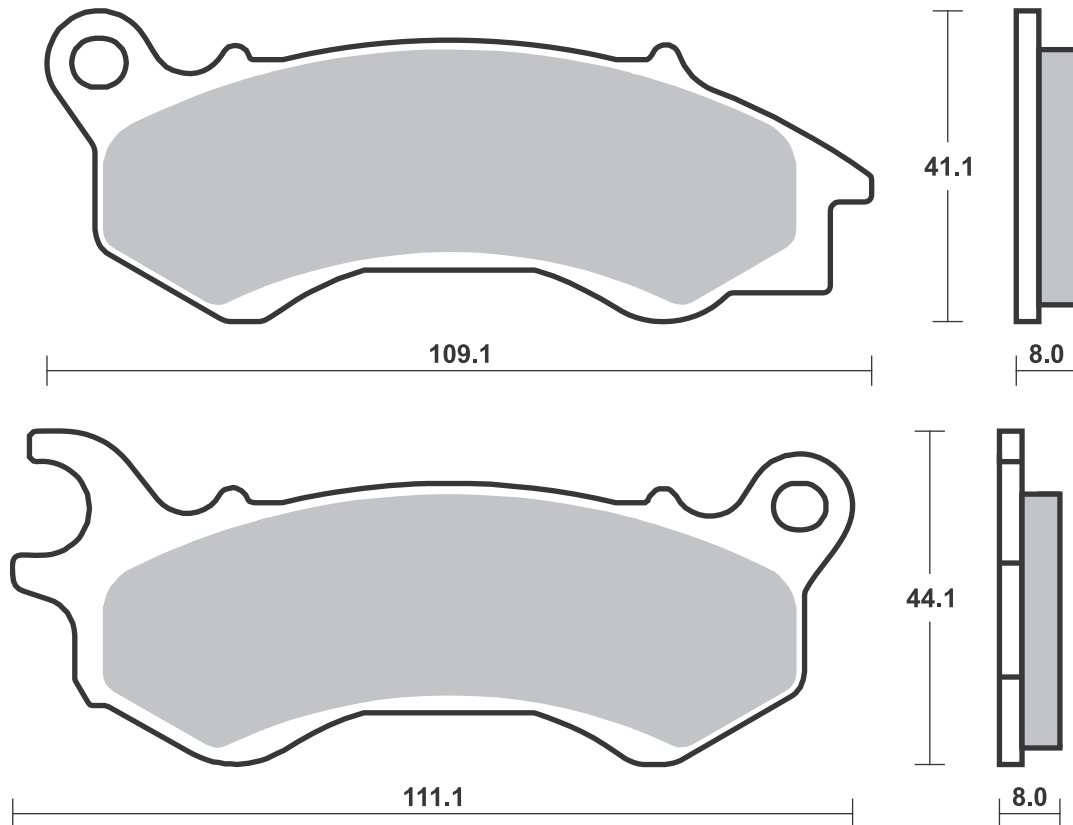



Available compounds

HF • CT

SBS 206

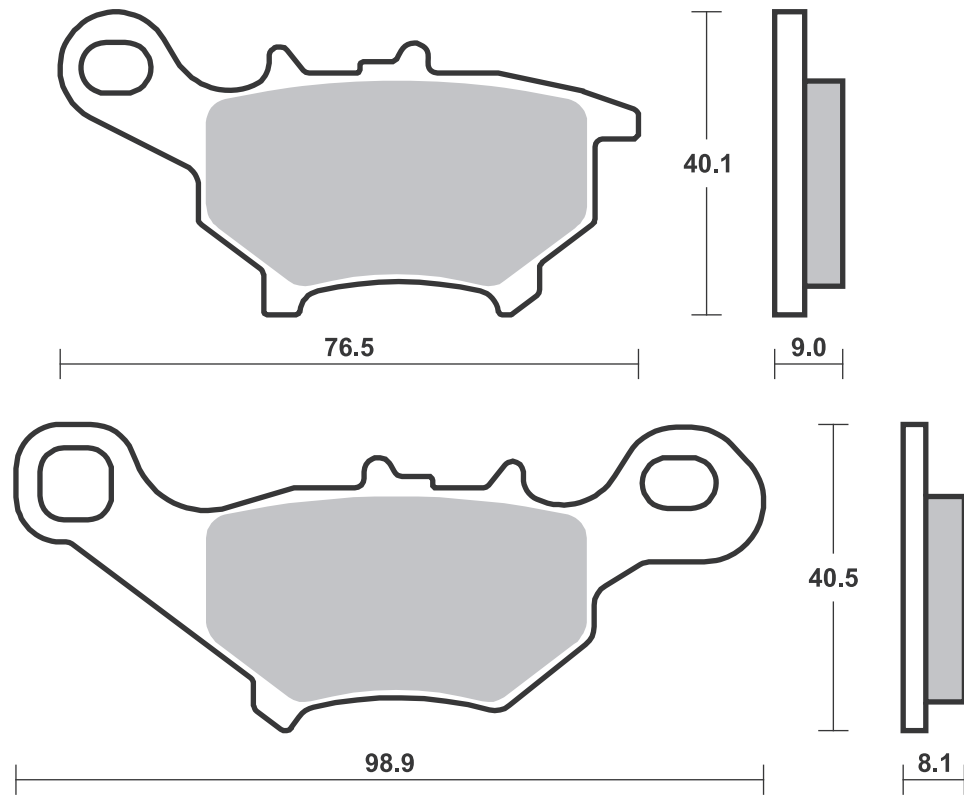

Available compounds

HF • CT

SBS 207

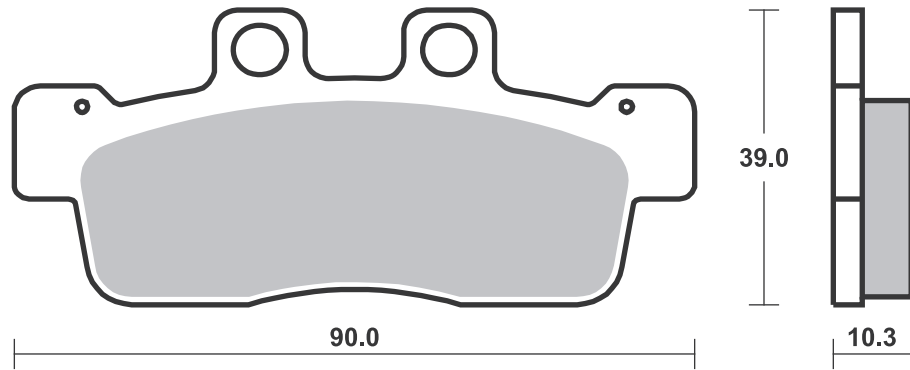



Available compounds

HF • CT

SBS 208

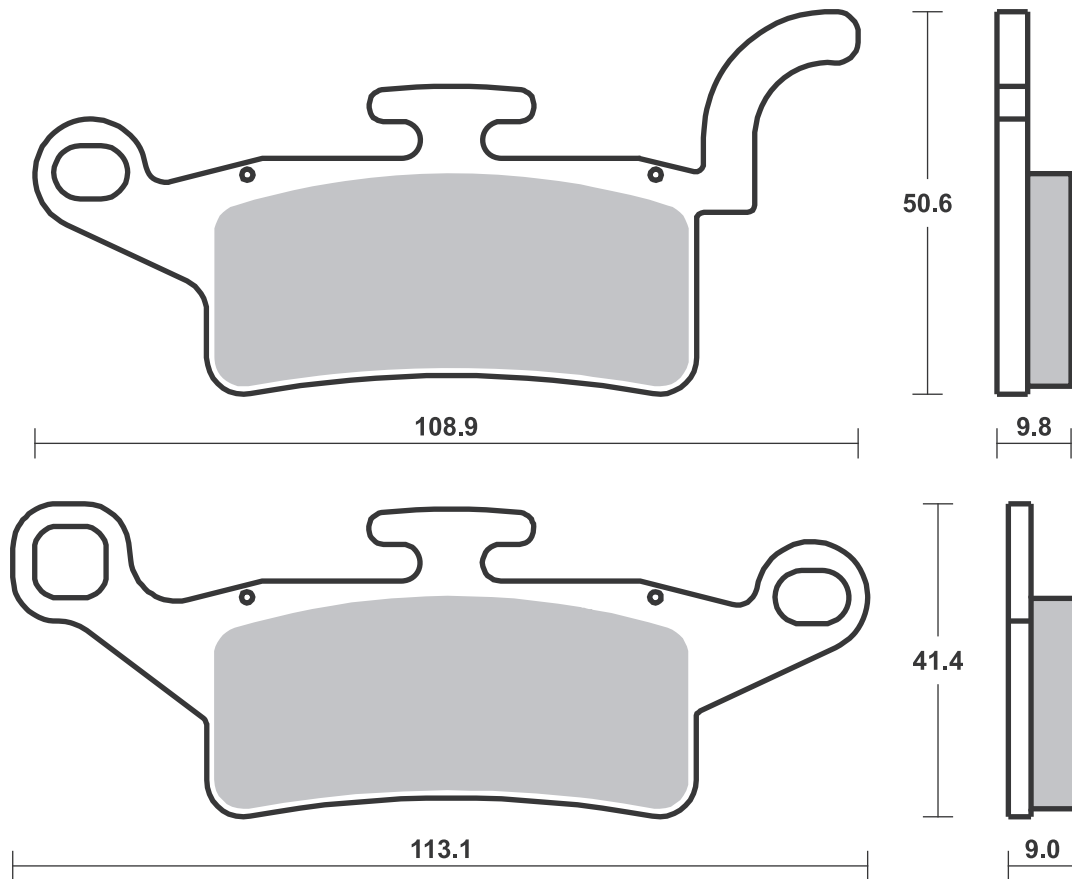

Available compounds

HF

SBS 209

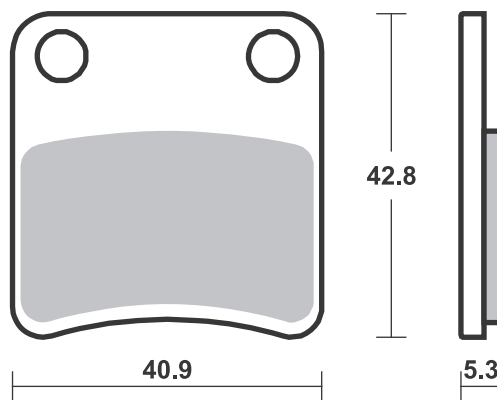



Available compounds

HF • CT • MS

SBS 210

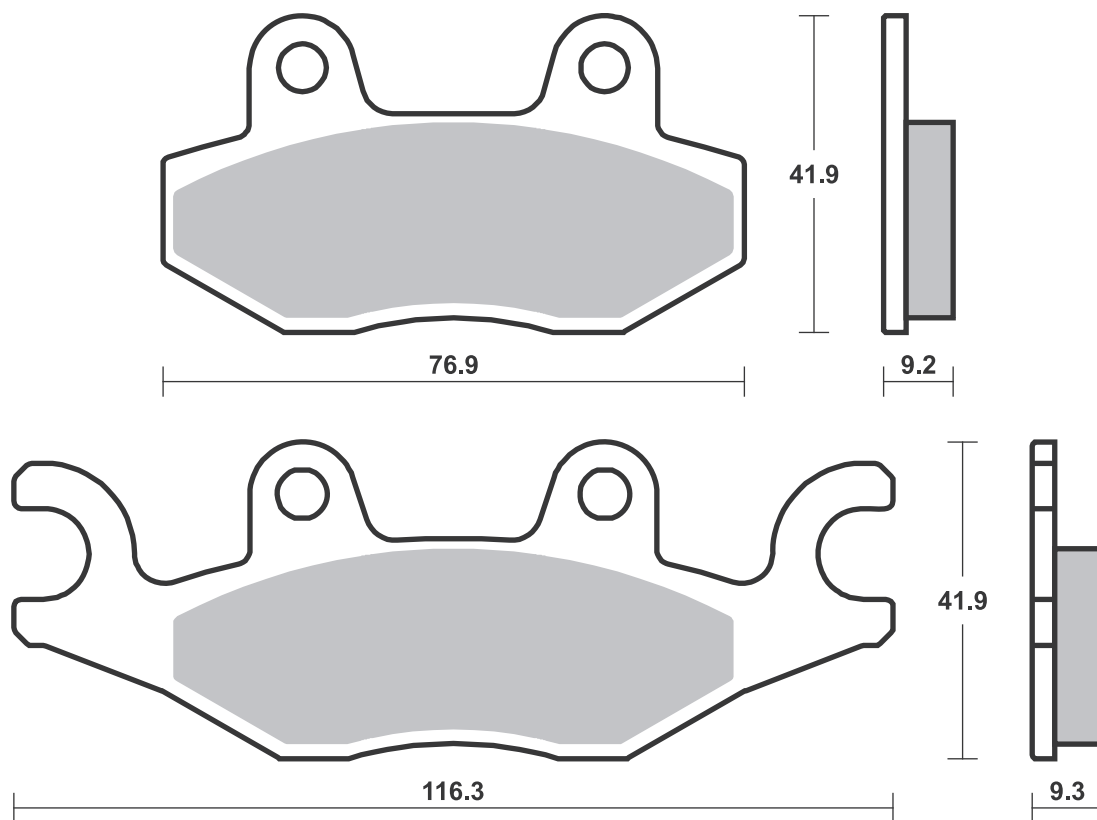

Available compounds

HF • CT • MS

SBS 212

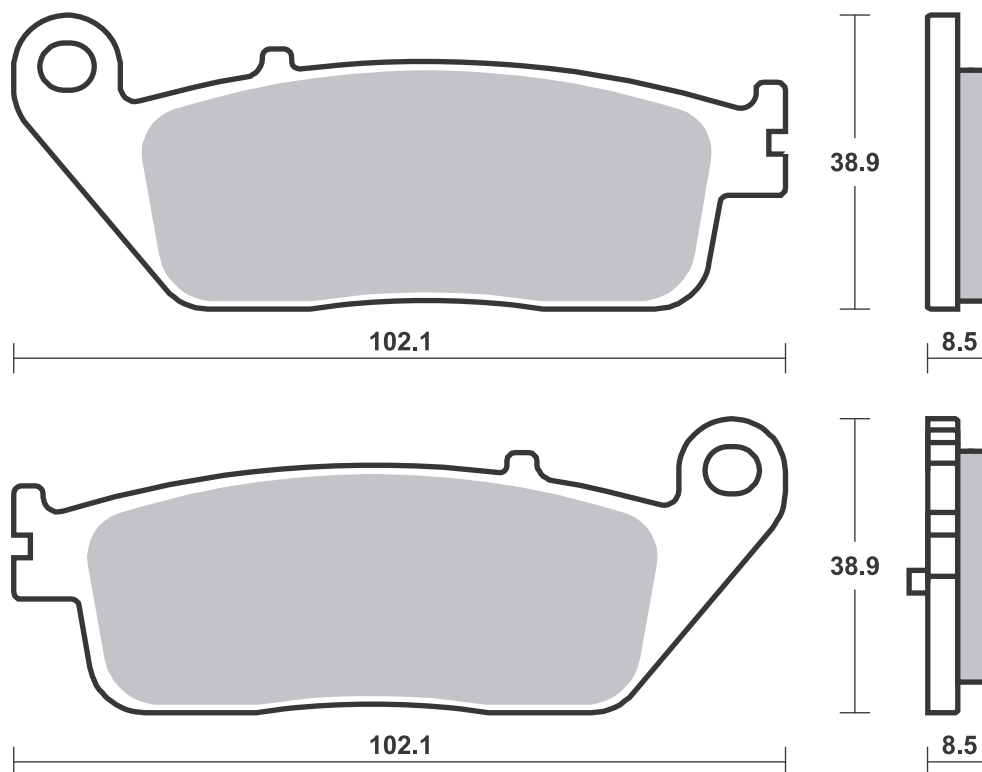





Available compounds

HF • CT • MS

SBS 214

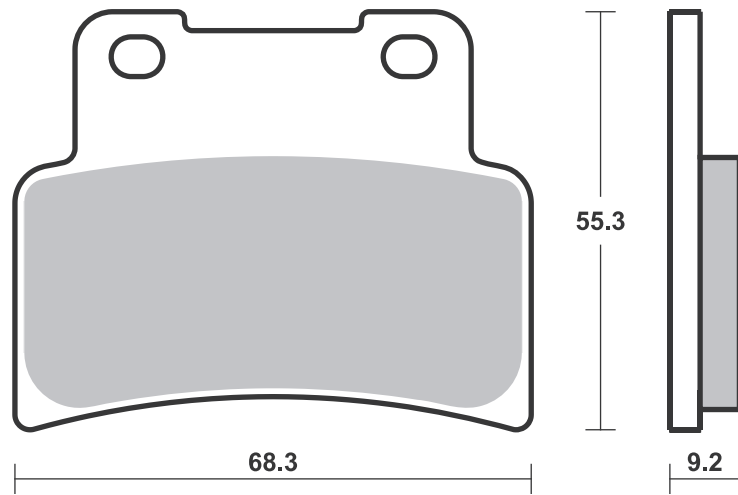

Available compounds

HF • CT • MS

SBS 215

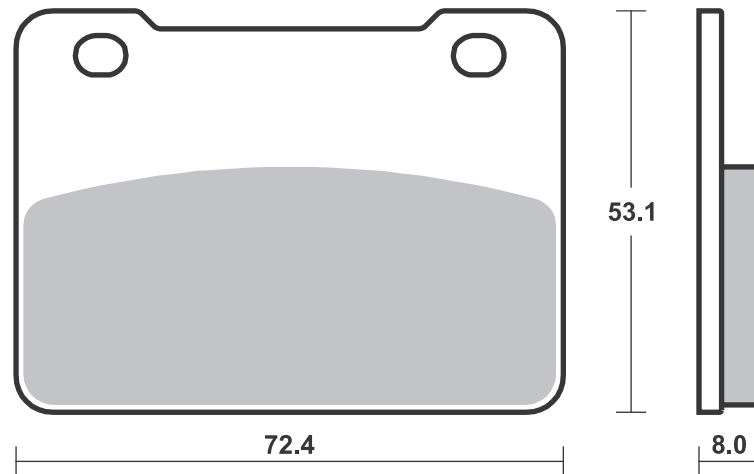



Available compounds

HF • CT

SBS 216

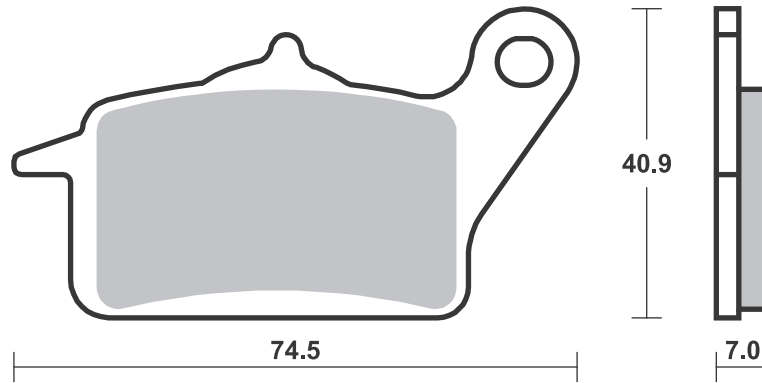
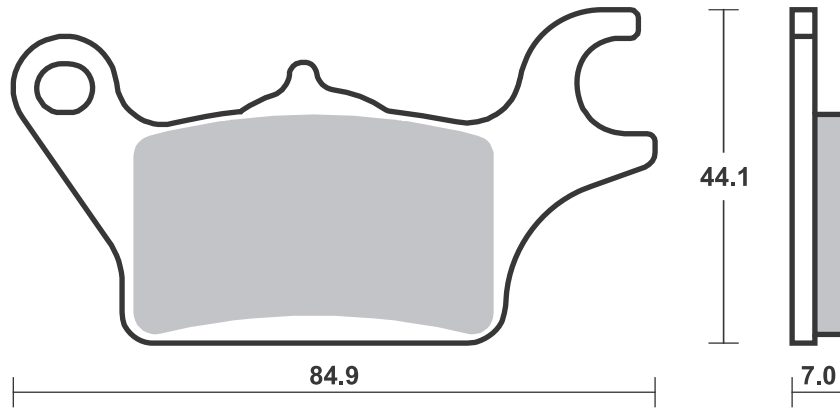

Available compounds

HF • CT • MS

SBS 218

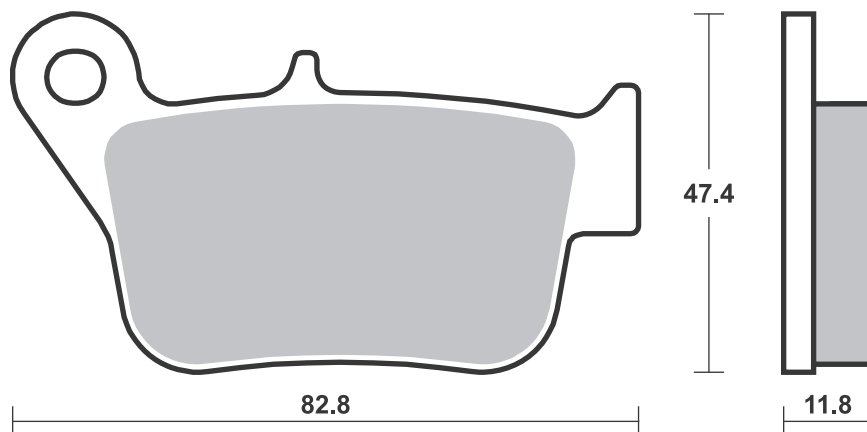
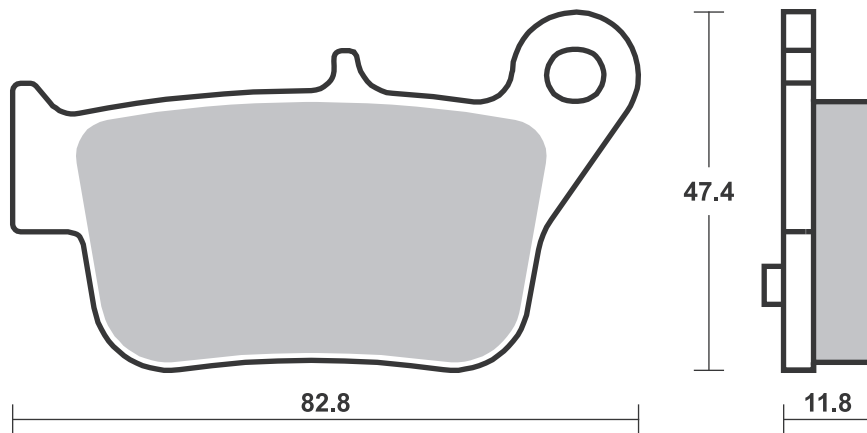



Available compounds

HF • CT • MS

SBS 221

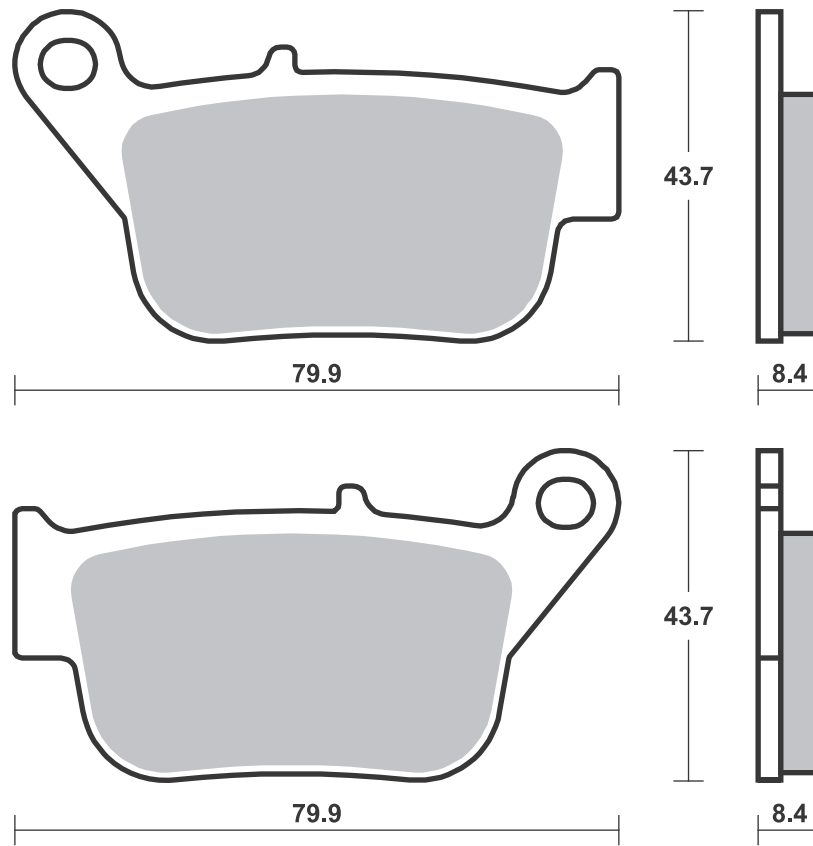

Available compounds

HF • CT

SBS 222

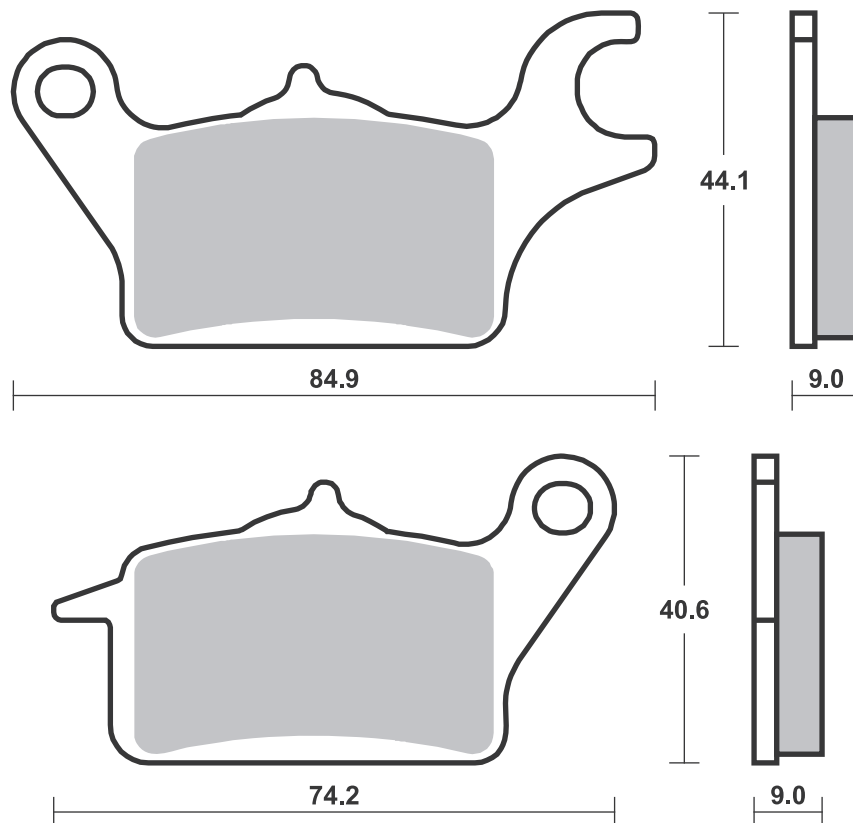



Available compounds

HF • CT

SBS 223

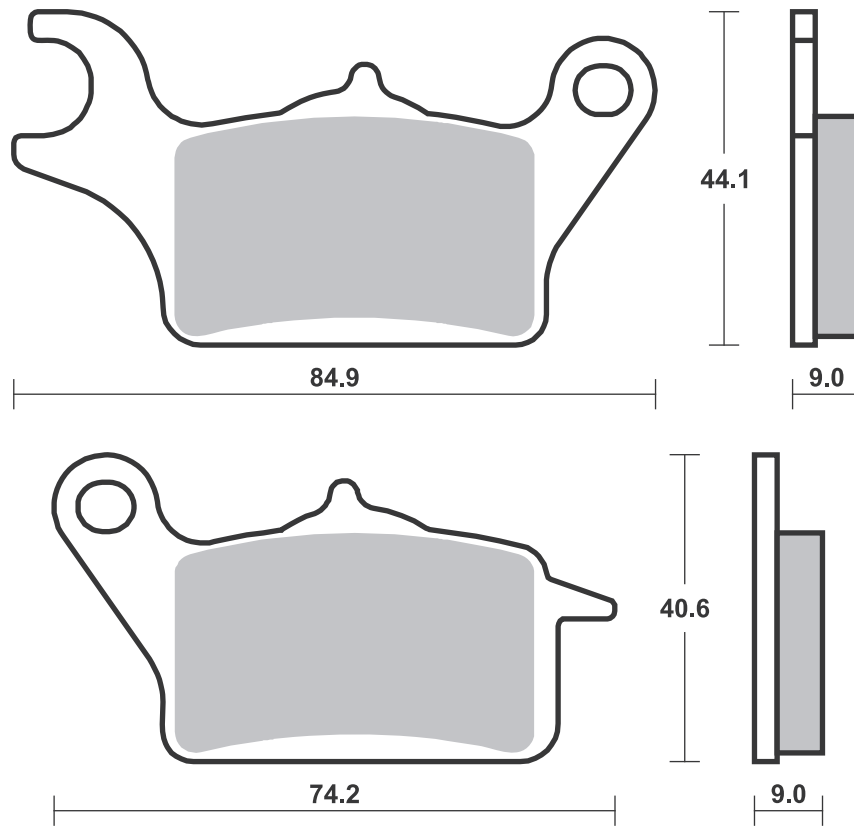

Available compounds

HF • CT • MS

SBS 224

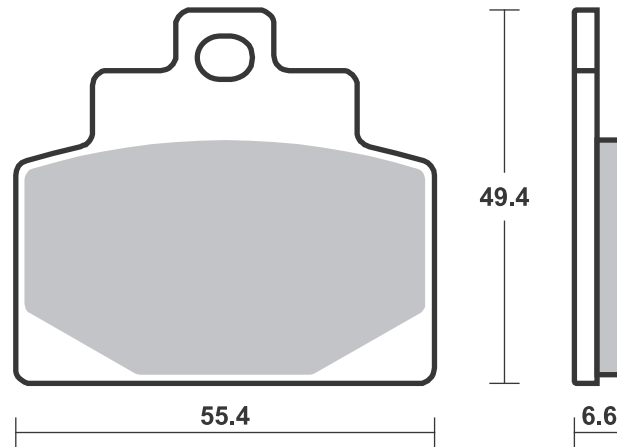





Available compounds

HF • CT

SBS 225

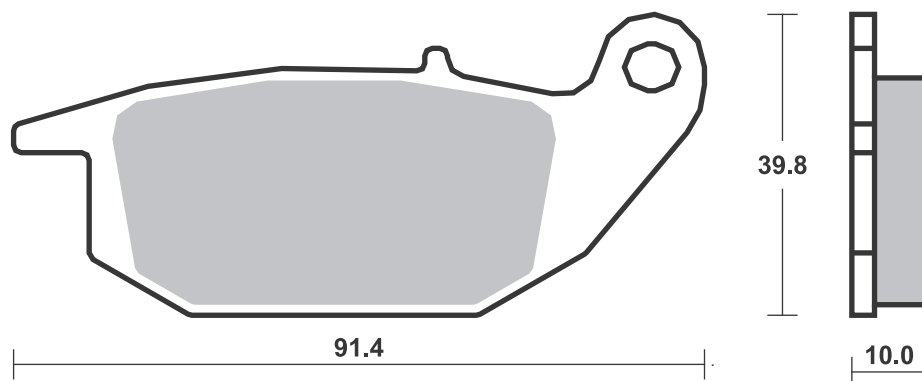
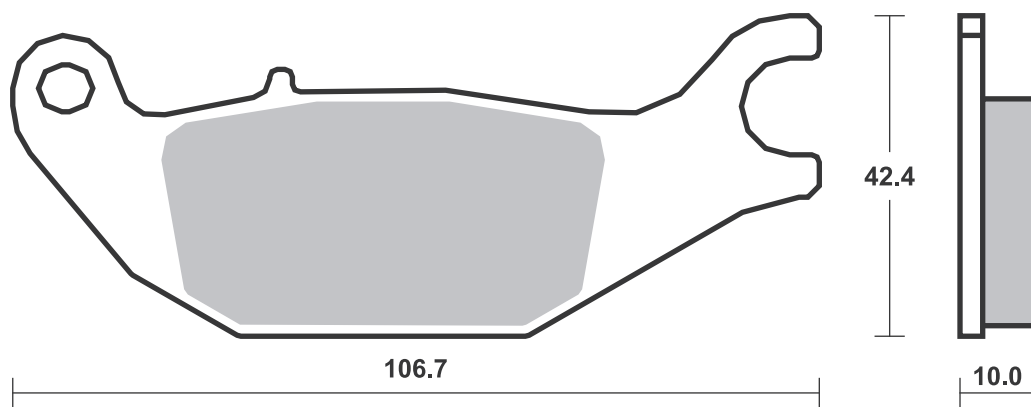

Available compounds

HF • CT

SBS 226

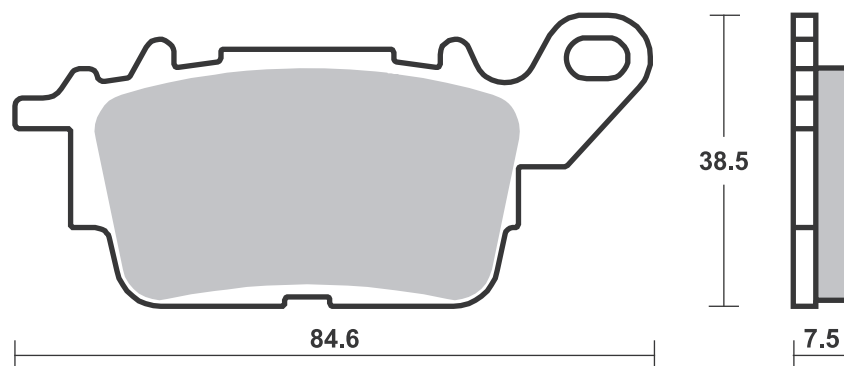
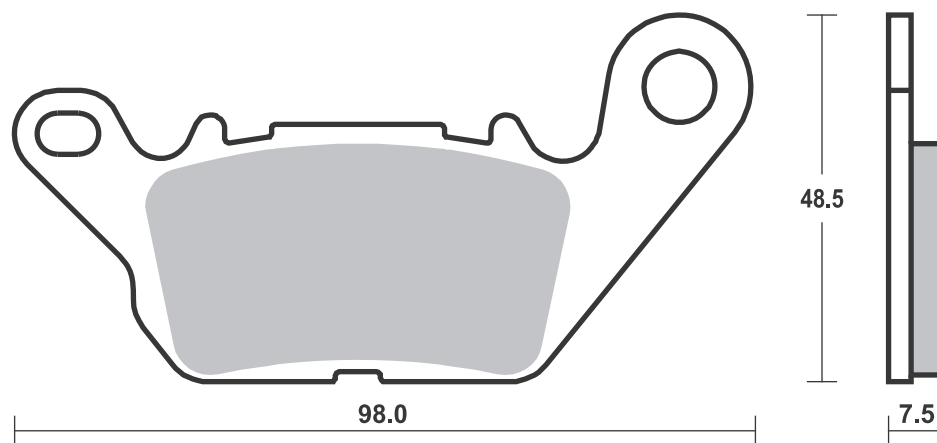

# Applications

## SBS 227 Recommended compound



### YAMAHA

	115 D'elight	14-20	HF
GPD	125 N-Max	15-19	CT
GPD	155 N-Max	15-19	CT
	300 Tricity	20-20	CT

## SBS 228 Recommended compound



### HONDA

PCX	125	18-20	CT
-----	-----	-------	----

### PIAGGIO VESPA

	125 Liberty		
	iGet 4T 3V	17-19	CT
	125 Medley	16-19	CT
	125 Medley S	17-19	CT
	125 New Liberty	16-19	CT
	150 Medley	16-19	CT

Brake Pad 1:1 Drawings, Compounds, Fitments

Available compounds

HF • CT

SBS 227

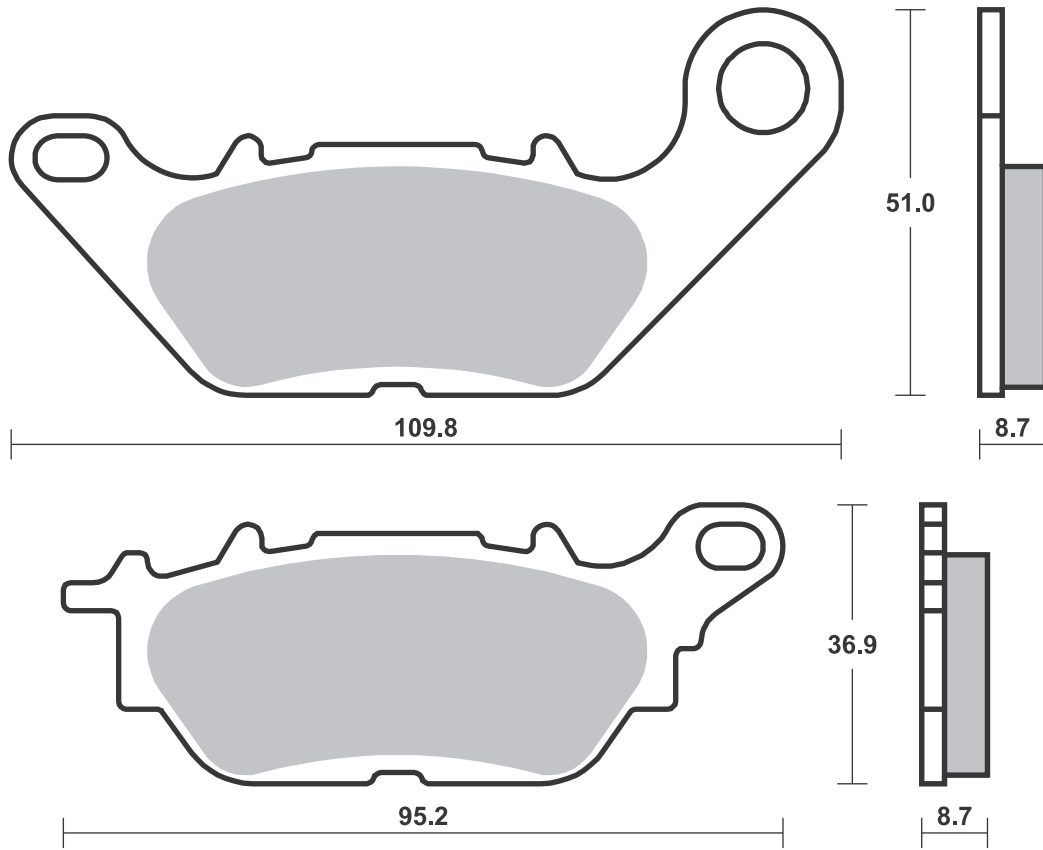

Available compounds

HF • CT

SBS 228

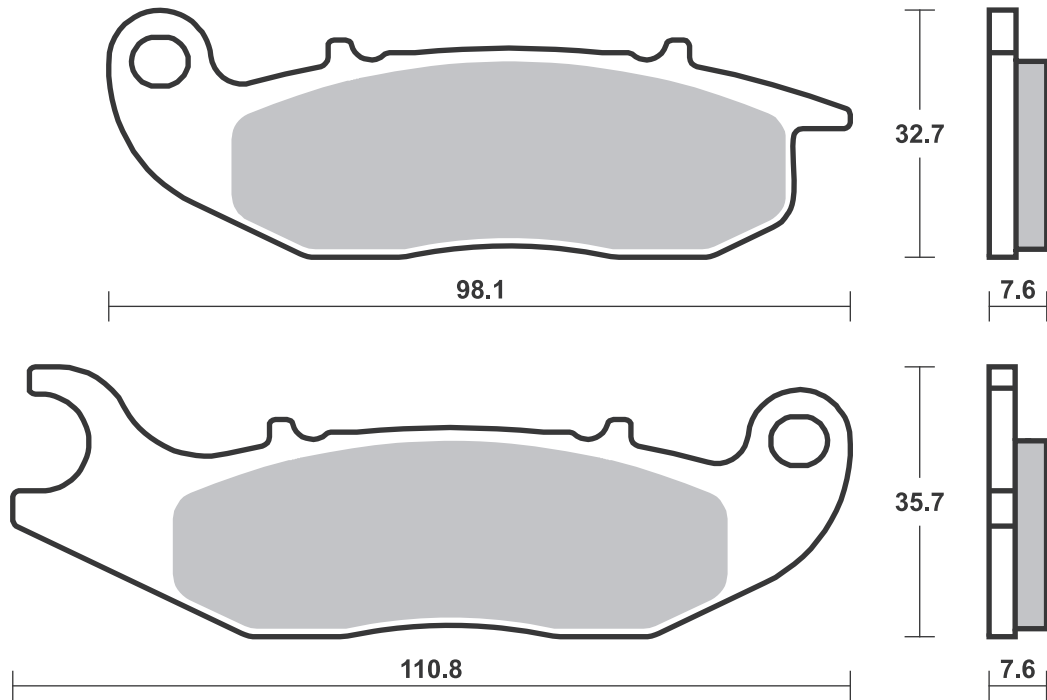



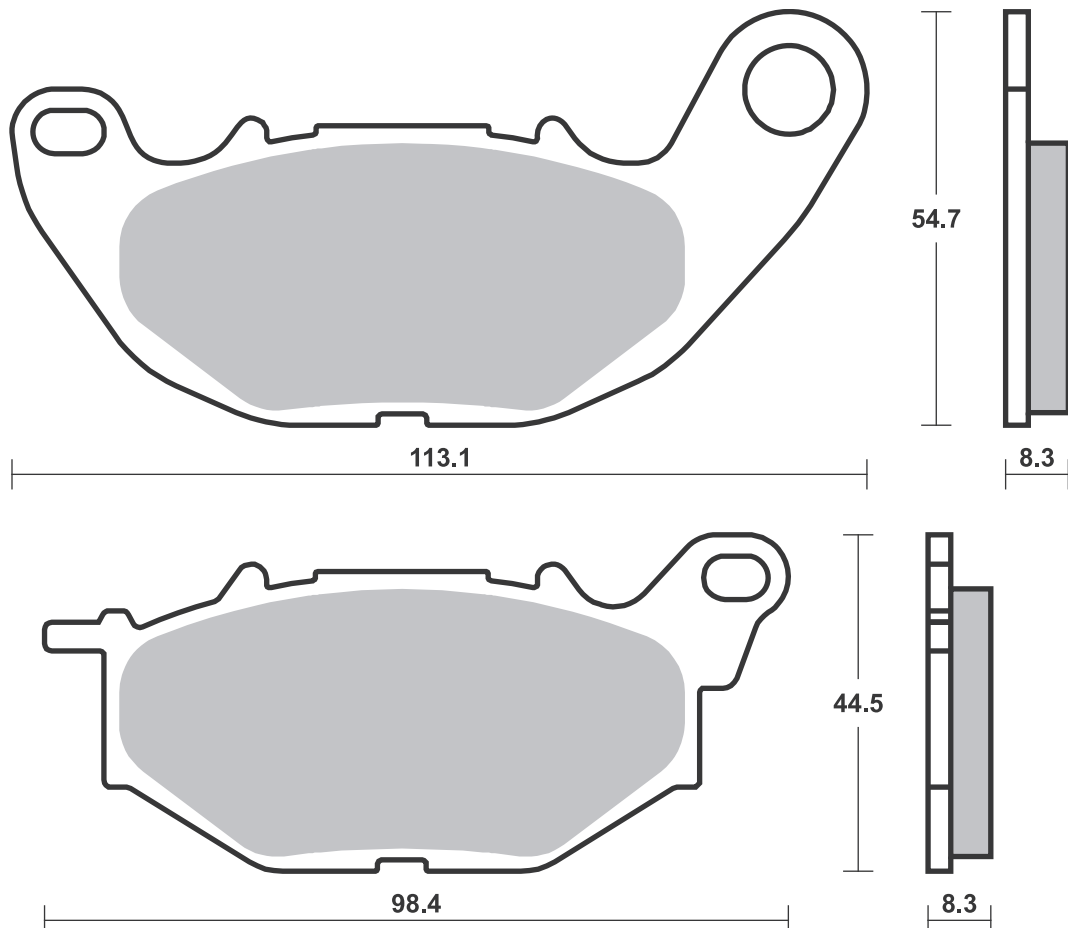

**SBS 230** Recommended compound



**YAMAHA**

YP	125 RA XMAX ABS	17-19	<b>CT</b>
YP	300 XMAX	17-20	<b>CT</b>

**SBS 231** Recommended compound



**BMW**

C	400 GT	19-22	<b>MS</b>
C	400 X	18-21	<b>MS</b>

Brake Pad 1:1 Drawings,  
Compounds, Fitments

Available compounds

HF • CT

SBS 230

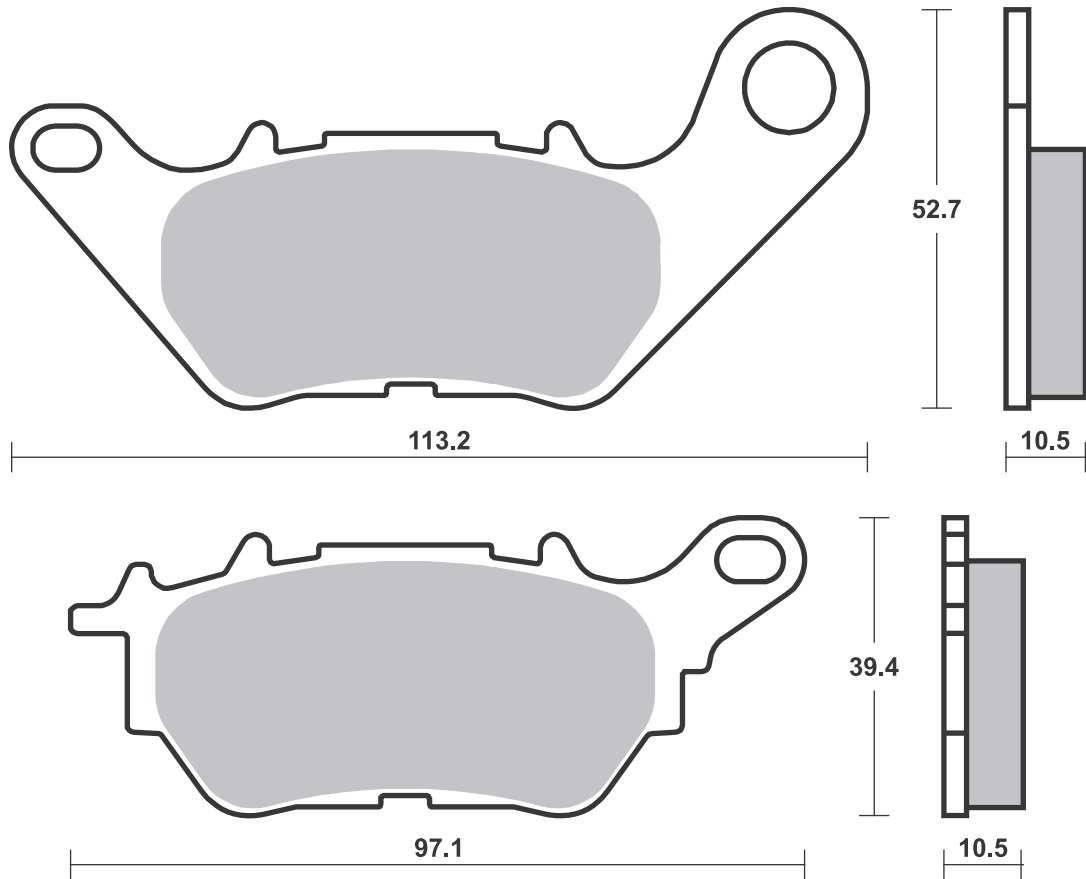

Available compounds

HF • CT • MS

SBS 231

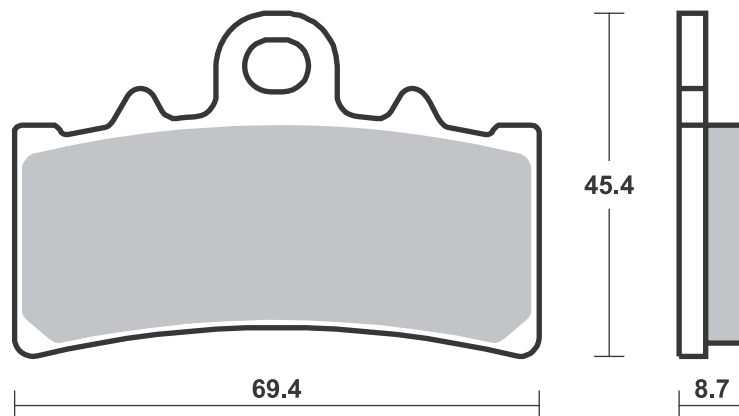

Brake Pad 1:1 Drawings,  
Compounds, Fitments

**SBS 232** Recommended compound



**KEEWAY**

125 Cityblade	17-19	HF
125 Logik	17-19	HF

**SBS 233** Recommended compound



**HONDA**

PCX 125 (Nissin cal.)	18-20	CT
PCX 150	18-20	CT

Brake Pad 1:1 Drawings,  
Compounds, Fitments



Available compounds

**HF**

**SBS 232**

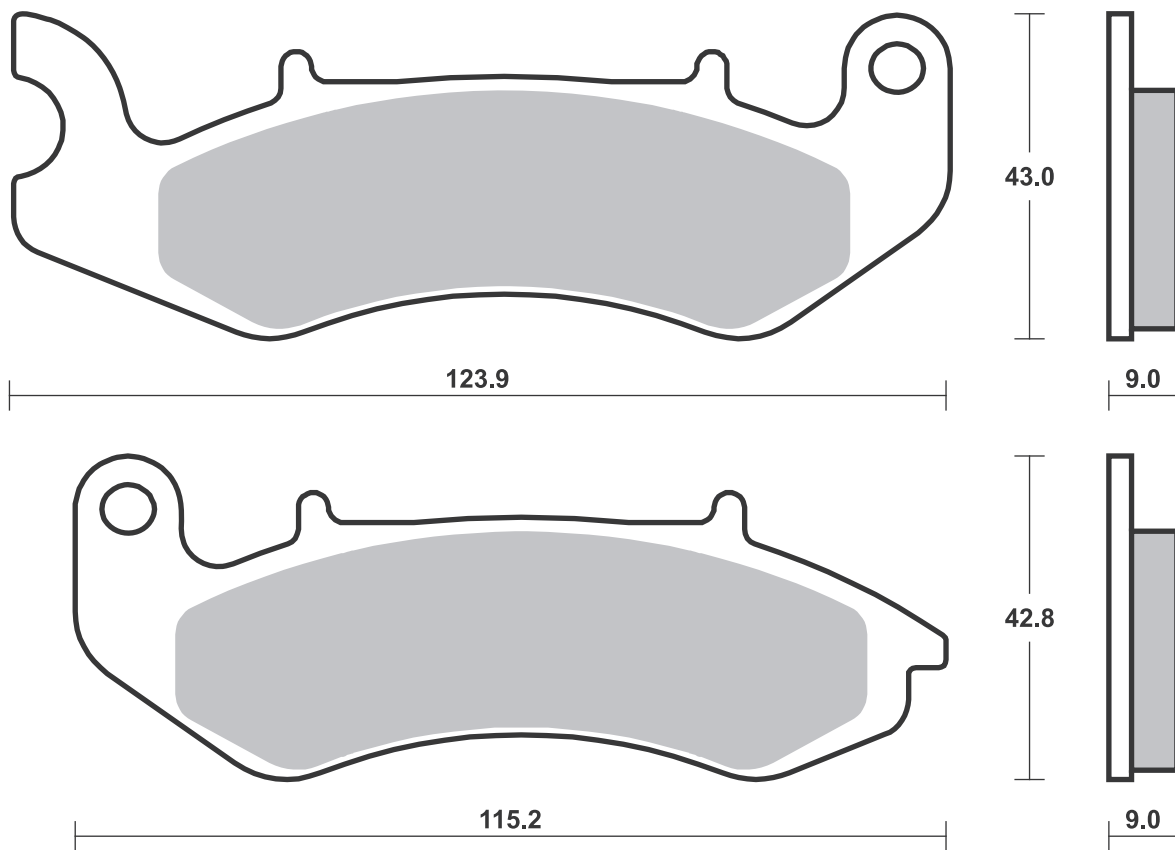

Available compounds

**HF • CT • MS**

**SBS 233**

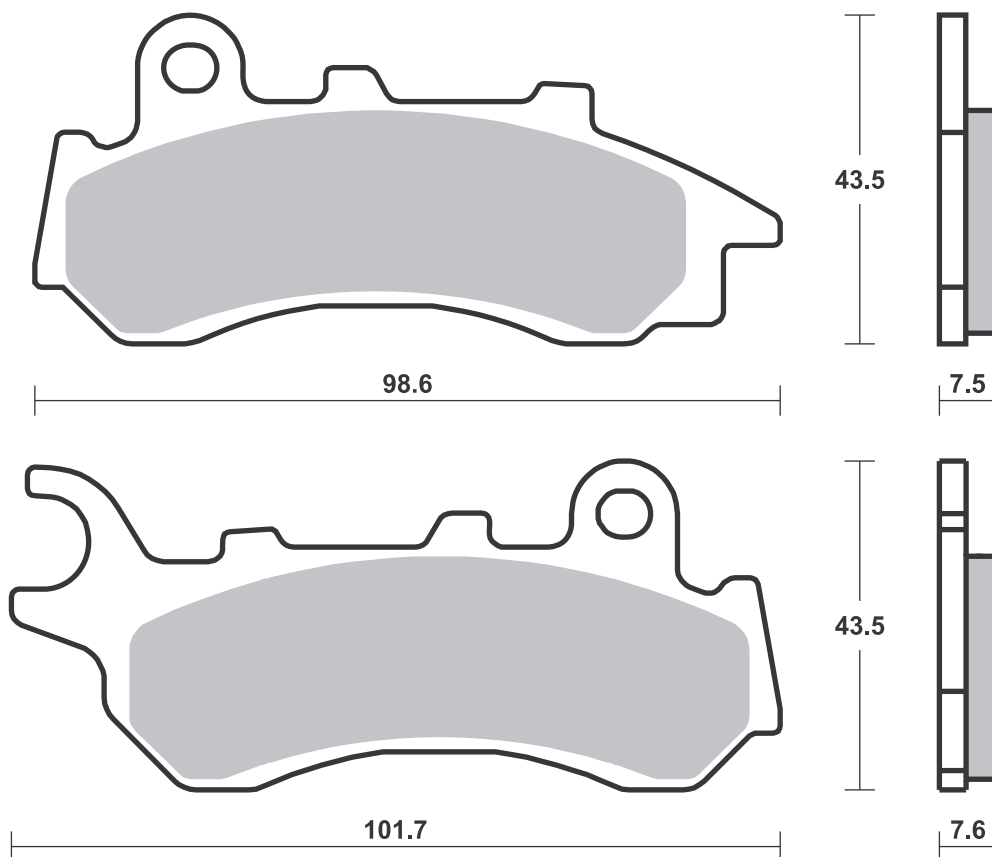



Available compounds

HF • CT

SBS 236

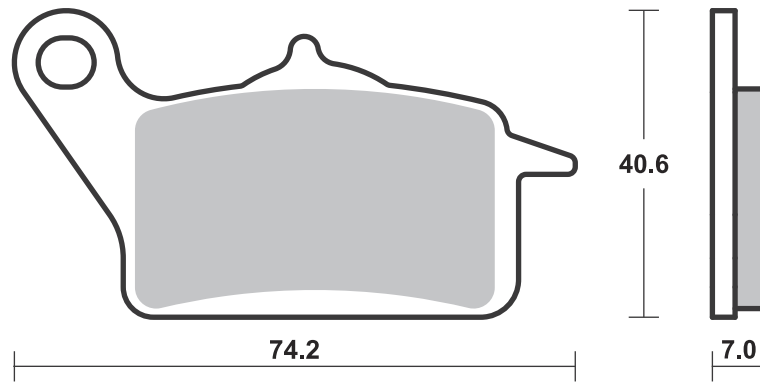
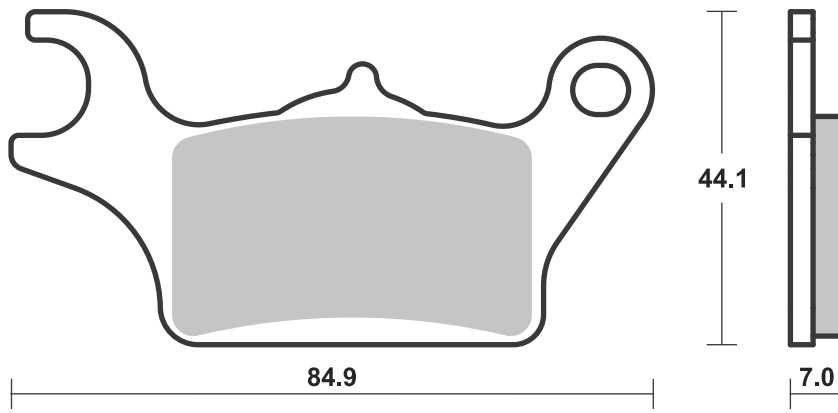

Available compounds

HF

SBS 237

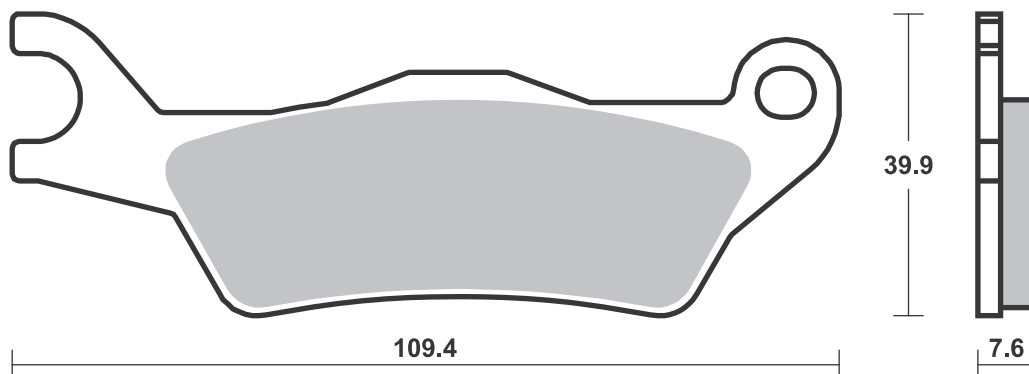
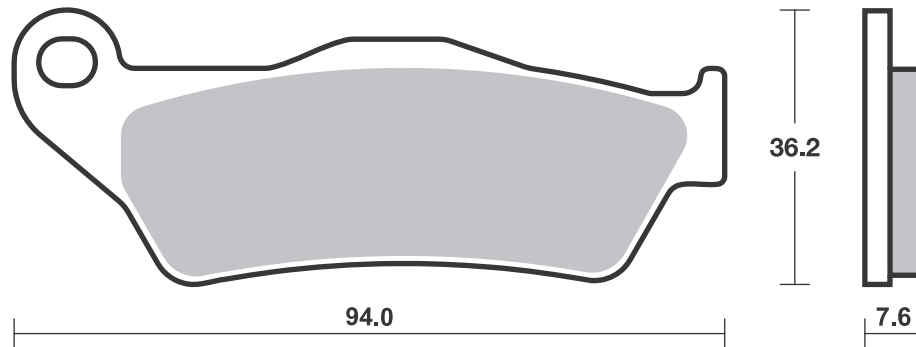

# Applications

## SBS 501 Recommended compound



<b>HONDA</b>		
CB	350 F, F1	73-76 <b>HF</b>
CB	360 G, T	73-76 <b>HF</b>
CB	400 F, F1, F2	75-79 <b>HF</b>
CB	450 K5, K6, K7	72-77 <b>HF</b>
CB	500 F	72-75 <b>HF</b>
CB	500 T	75-78 <b>HF</b>
CB	550 F	75-79 <b>HF</b>
CB	550 K	74-78 <b>HF</b>
CB	750 A	76-78 <b>HF</b>
CB	750 F1	75-76 <b>HF</b>
CB	750 K Four	77-78 <b>HF</b>

## SBS 502 Recommended compound



<b>HONDA</b>		
CB	750 K0-K6 Four	70-76 <b>HF</b>

## SBS 503 Recommended compound



<b>KAWASAKI</b>		
S2A	350	73-73 <b>HF</b>
KH	500 H1	74-75 <b>HF</b>
KZ	750 H	72-75 <b>HF</b>
<b>SUZUKI</b>		
RE	5M, A	75-77 <b>HF</b>
GT	125	75-77 <b>HF</b>
GT	185	75-77 <b>HF</b>
GT	250	73-77 <b>HF</b>
GT	380	73-77 <b>HF</b>
GT	500	75-77 <b>HF</b>
GT	550	73-77 <b>HF</b>
GT	750	73-77 <b>HF</b>

Brake Pad 1:1 Drawings, Compounds, Fitments

Available compounds

HF • DCC

SBS 501

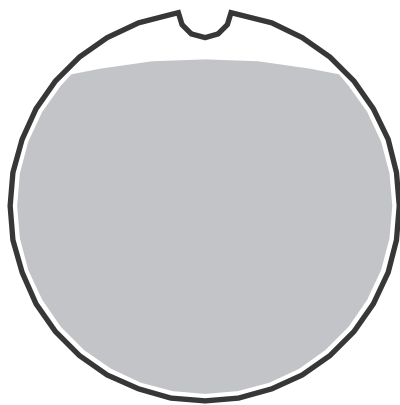

51.6

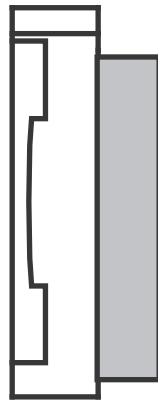

19.5

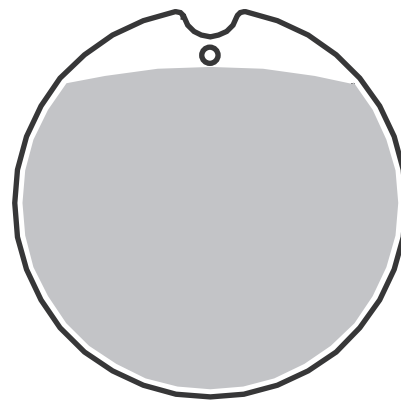

51.9

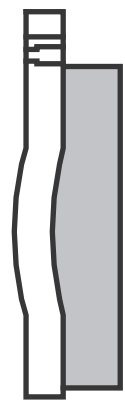

13.7

Available compounds

HF

SBS 502

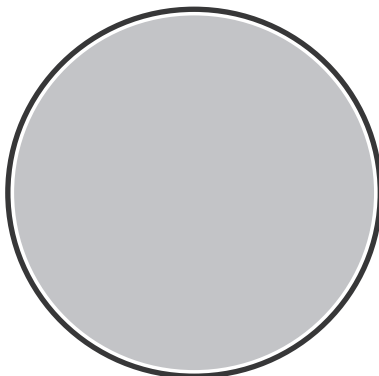

49.9

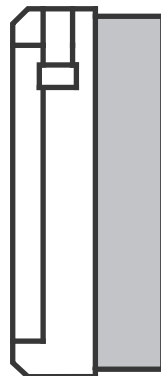

20.0

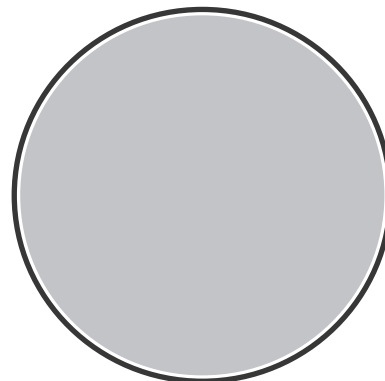

49.9

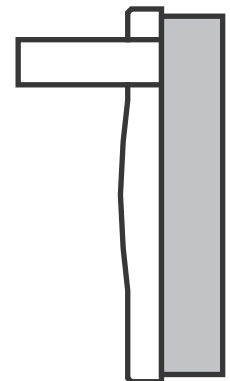

13.5

Available compounds

HF

SBS 503

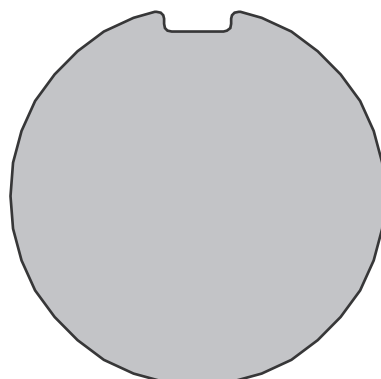

50.3



12.5

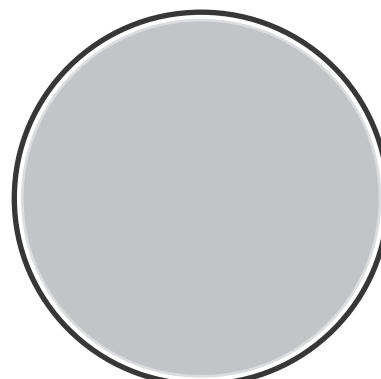

49.5



10.0

## Applications

### SBS 504 Recommended compound



#### ISR CALIPERS

2 Piston (22-023/026)

#### YAMAHA

RD	250	73-76	HF	
RD	250	77-77	HF	HF
TZ	250	82-85	HF	
RD	350	73-79	HF	
XS	360 B	76-76	HF	
TX	500 A, B	74-77	HF	
XS	500	75-76	HF	
TX	650	72-73	HF	
XS	650	75-77	HF	
TX	750	73-74	HF	
TX	750 A	73-76	HF	

### SBS 505 Recommended compound



#### NORTON

MK2	850 Commando	73-75	HF	
MK3	850 Commando	75-77	HF	HF

### SBS 506 Recommended compound



#### BENELLI

	750 Sei	75-78	HF	
	900 Sei	84-84	HF	HF

#### BERINGER

2 Piston Classic Billet Caliper

#### BIMOTA

	all models	82-88	HF	HF
SB3	1000 D	83-83	HF	HF

#### BMW

R65	650 GS	87-92	HF	
R65	650 LS	82-85	HF	
R65/1	650	86-86		HF
K75	750	90-90		LS
K75	750 C	85-88	HF	
K75	750 RT	91-96		LS

#### BMW

K75	750 S, C	85-95	HF	HF
R80	800	77-85	HF	
R80	800 G/S P.-D.	86-86	HF	
R80	800 GS	81-87	HF	
R80	800 GS	91-92	HS	
R80	800 R	91-95		LS
R80	800 RT	83-83	HF	
R80/7	800	79-81		HF
K1	1000	89-89		LS
K100	1000 LT	87-87	HF	HF
K100	1000 LT	92-94		LS
K100	1000 LT ABS	89-89		LS
K100	1000 RS	90-92		LS
K100	1000 RS ABS	88-89		LS
K100	1000 RS, RT	83-89	HF	HF
R100	1000	81-84	HF	HF
R100	1000 CS,RS, RT	81-84	HF	HF

#### BMW

R100	1000 R	91-95		LS
R100	1000 RS	76-80		HF
R100	1000 RS	93-95		LS
R100	1000 S	78-80		HF
R100	1000 T	79-84		HF
K1100	1100 LT/SE	92-00		LS
K1100	1100 RS	93-96		LS
R1100	1100 RS	93-01		LS
K	1200 GT (K41) With			
	Integral ABS	02-05		LS
K	1200 RS	97-05		LS

#### BREMBO RACING CALIPERS

	108N, P2 38			
	F08			

Available compounds

**HF • DCC**

**SBS 504**

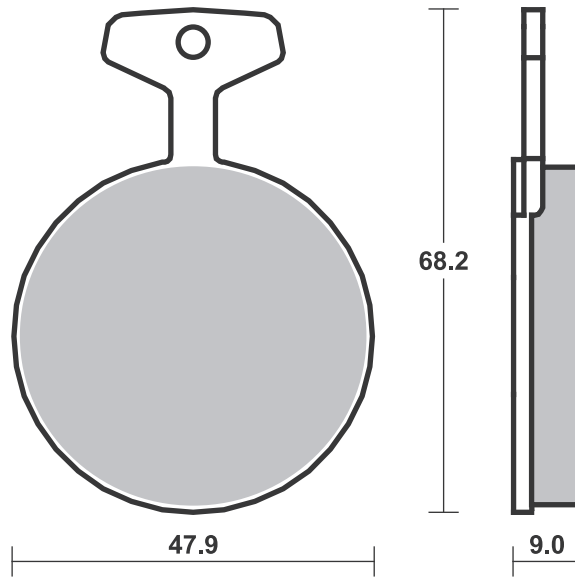

Available compounds

**HF**

**SBS 505**

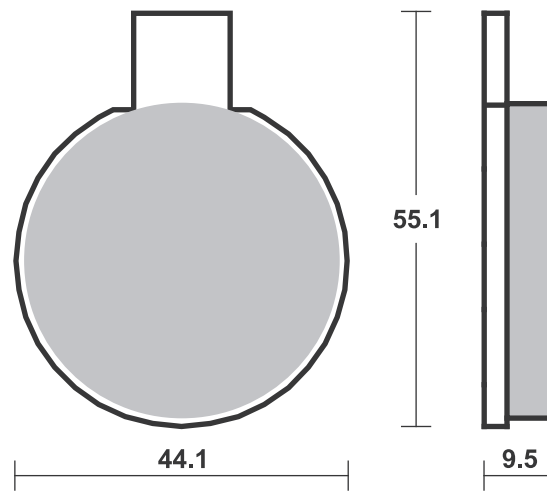

Available compounds

**HF • HS • LS • DCC • DS-1 • DS-2 • H.HF • H.CT • H.LS** SBS 506

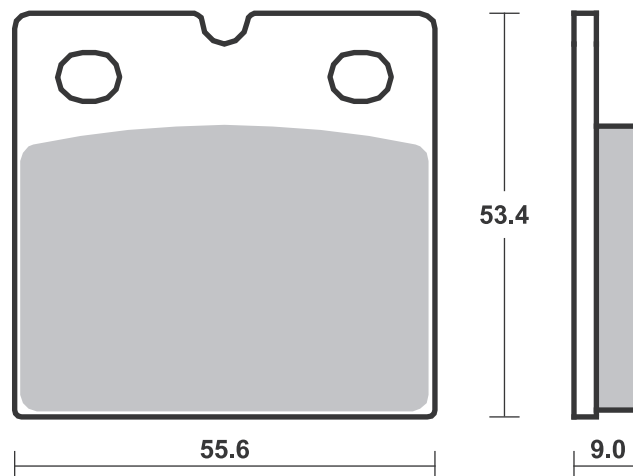



DUCATI			
250 Desmo	70-77	HF	
350 Desmo	70-77	HF	
350 F3	86-90	HF	HF
500 Sport	77-82	HF	HF
600 Pantah TL, SL	78-89	HF	HF
600 SL, TL Pantah	76-89	HF	
650 Pantah	84-89	HF	HF
750 F1	86-98	HF	HF
750 GT	74-76	HF	
750 Paso	86-88	HF	
750 Sport	90-90	HS	LS
750 SS	74-76	HF	HF
750 SS	91-98	HF	
851 Strada	91-92	HF	
860 GT	75-77	HF	
860 GT	85-85	HF	HF
888 Roche Replica	91-91	HF	
900 GTS	77-79	HF	
900 Mike Hailwood			
Replica	85-86	HF	HF
900 S2 Desmo	85-85	HF	HF
900 Sport	77-78	HF	HF
900 SS	78-89	HF	HF
906 900 Paso	89-89	HF	
1000 /6 Mike			
Hailwood			
Replica	85-86	HF	HF
1000 Mille Replica	84-85	HF	HF
1000 S2 Desmo	85-85	HF	HF
INDIAN			
1700 Chief			
Blackhawk	11-13	H.LS	
1700 Chief Bomber	10-13	H.LS	
1700 Chief Classic	10-13	H.LS	
1700 Chief Dark			
Horse	10-13	H.LS	
1700 Chief Deluxe	09-13	H.LS	
1700 Chief			
Roadmaster	09-13	H.LS	
1700 Chief Standard	09-13	H.LS	
1700 Chief Vintage	09-13	H.LS	



JAWA			
CZ 125 2T	95-00	HF	
CZ 125 MX	95-00	HF	
CZ 180	92-92	HF	
300 Trail	93-93	HF	
LAVERDA			
SFC 600	86-89	HF	HF
650 V-Six	93-93	HS	LS
1000 Jota	76-79	HF	HF
3C 1000 3CE, 3CL	74-75	HF	HF
RGS 1000	83-83	HF	HF
RGS 1000 Jota	86-86	HF	HF
SFC 1000	85-86	HF	HF
TGA 1000 Executive	84-84	HF	HF
1200 Mirage	78-80	HF	HF
MOTO-GUZZI			
NTX 350	90-90	HF	
V35 350 C	82-86	HF	
V35 350 Florida	85-86	HF	
V35 350 GT	90-90	HF	
V35 350 III	87-87	HF	HF
V35 350 TT	86-86	HF	HF
NTX 650	90-02	HF	
V65 650 Florida	86-94	HF	HF
V65 650 GT	90-94	HF	
NTX 750	90-93		LS
S3 750	75-76	HF	
SP 750	91-92	HS	LS
V75 750	86-88	HF	HF
V75 750 Duna	86-90	HF	HF
V75 750 TT Paris-Dakar	86-86	HF	HF
850 Le Mans	76-79	HF	HF
T 850	74-76	HF	
T3 850	75-80	HF	HF
T4 850	75-82	HF	HF
T5 850	75-88	HF	HF
T5 850 N.T.	86-88	HF	HF
1000 California II	85-88	HF	HF
1000 California III C	91-95	HS	LS
1000 California III,			
Fuel Injection	89-89	HF	HF



MOTO-GUZZI			
1000 Daytona	91-02		HF
1000 Le Mans IV	85-89	HF	HF
1000 Le Mans, V	90-98	HS	LS
GT 1000 V	91-91	HS	LS
S 1000	90-90	HS	LS
SP 1000 III	91-94	HS	LS
SP 1000 Le Mans	79-83	HF	
V 1000 Strada	93-94	HF	
1100 California	96-99	HS	LS
NORTON			
600 Commander	90-90	HF	HF
600 Interpol	83-88	HF	HF
600 Wankel Classic	88-89	HF	HF
F-1 600	90-90		HF
TRIUMPH			
750 Bonneville U.K.	87-87	HF	HF



YAMAHA			
XS 250 C	77-78	HF	HF
XS 250 D, E	79-80	HF	
XS 360 C, D	77-77	HF	HF
XS 400	77-77	HF	HF
SR 500	78-91	HF	
XS 500	77-81	HF	HF
XJ 650	80-82	HF	
XJ 650 RJ Seca	81-83	HF	
XS 650	75-85	HF	HF
XS 650	77-79	HF	
XS 650	80-82		HF
XS 650 SE	80-82	HF	HF
XS 650 SJ, SK	82-82	HF	
XS 650 SK, Heritage	83-83	HF	HF
XJ 750 E	81-83	HF	
XS 750	77-80	HF	HF
XS 750 H, J, K	81-82		HF



YAMAHA			
XS 750 SE	79-80		HF
XS 850	80-80	HF	HF
XV 920	81-82	HF	
XS 1100 E,F,G,H	78-81	HF	HF
XS 1100 SF, SG, SH, LG	79-81		HF



Available compounds

**HF • HS • LS • DCC • DS-1 • DS-2 • H.HF • H.CT • H.LS SBS 506**

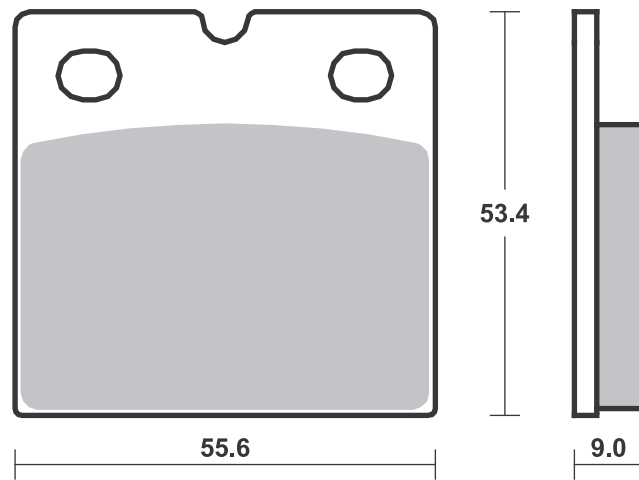

Available compounds

**HF**

**SBS 507**

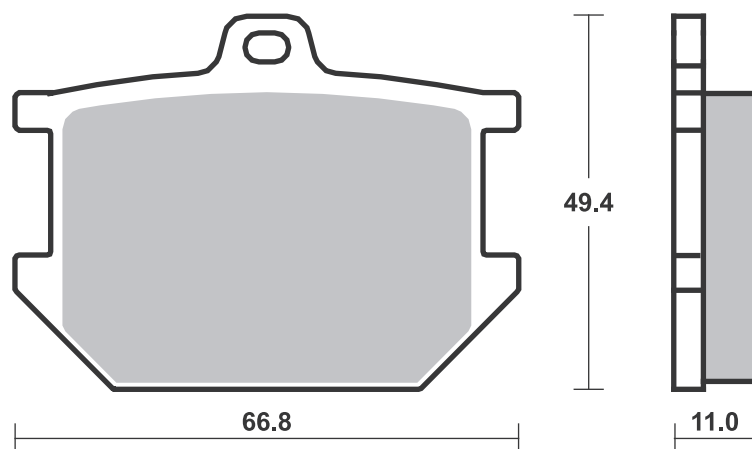

## Applications

### SBS 508 Recommended compound



<b>HONDA</b>			
CB	750 SS	77-79	<b>HF</b>
GL	1000 K1, K2 Gold Wing	75-77	<b>HF</b>

### SBS 509 Recommended compound



<b>HONDA</b>			
CB	750 F1	75-76	<b>HF</b>
GL	1000 K1, K2 Gold Wing	75-77	<b>HF</b>
GL	1000 K3 Gold Wing	78-79	<b>HF</b>
<b>PERFORMANCE MACHINE</b>			
162 X 2			

### SBS 510 Recommended compound



<b>KAWASAKI</b>			
KH	250	76-80	<b>HF</b>
KH	400	76-78	<b>HF</b>
KZ	400	74-77	<b>HF</b>
KZ	400 H1 (LTD)	79-79	<b>HF</b>
KZ	440	80-82	<b>HF</b>
KZ	440 C	80-81	<b>HF</b>
KZ	440 LTD	80-82	<b>HF</b>
KH	500	76-79	<b>HF</b>
KZ	550 A1	80-80	<b>HF</b>
KZ	650	78-82	<b>HF</b>
KZ	650 C	78-79	<b>HF</b>
KZ	750 B	76-79	<b>HF</b>
KZ	750 LTD	80-81	<b>HF</b>
KZ	900	76-76	<b>HF</b>
KZ	900	76-77	<b>HF</b>
KZ	900 A	76-77	<b>HF</b>
KZ	1000	76-81	<b>HF</b>



<b>KAWASAKI</b>			
KZ	1000 GL	80-82	<b>HF</b>
KZ	1000 H1	80-83	<b>HF</b>

Available compounds

HF

SBS 508

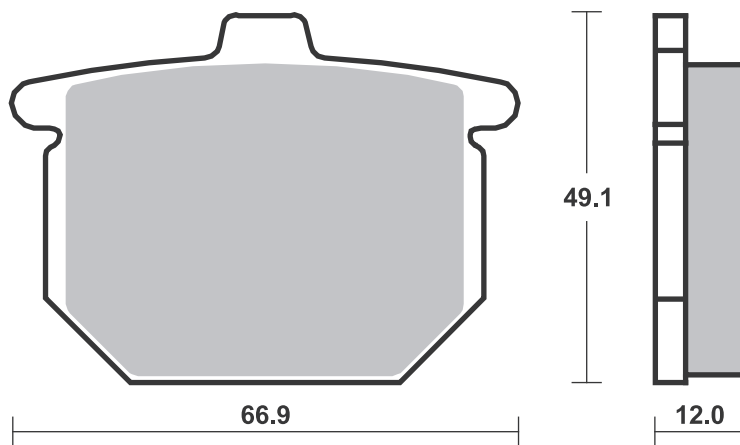

Available compounds

HF • H.HF • H.CT

SBS 509

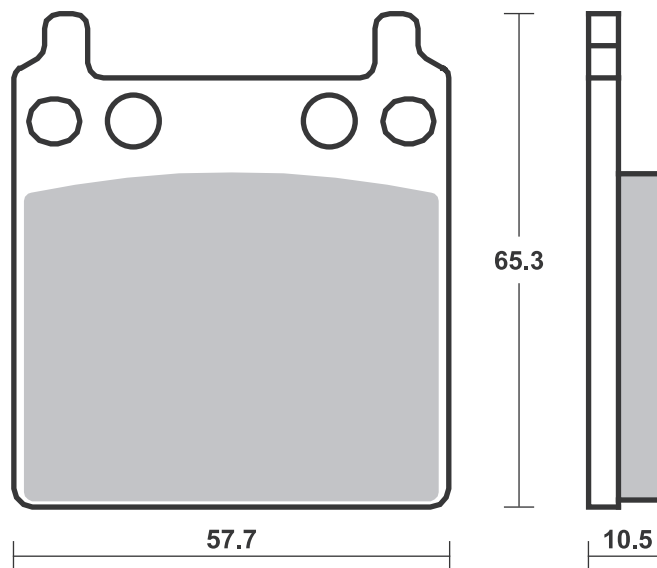

Available compounds

HF

SBS 510

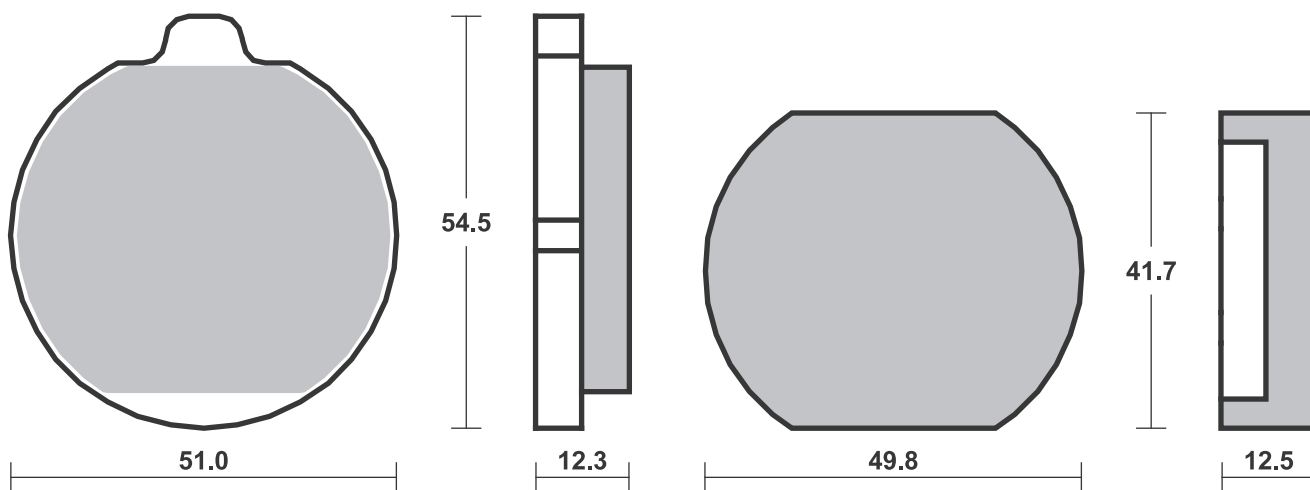

## Applications

### SBS 511 Recommended compound



SUZUKI			
GS	400	77-78	HF
GS	425	79-79	HF
GS	750	76-77	HF
GS	750 D	77-79	HF
GS	750 E	77-79	HF
GS	850	79-80	HF

### SBS 512 Recommended compound



GMA			
2 Piston Caliper,			
large Model A			

KAWASAKI			
KZ	650	78-82	HF
KZ	1000	76-81	HF
KZ	1000 F1	80-82	HF
KZ	1000 GL	80-82	HF
KZ	1000 H1	80-83	HF
KZ	1000 MKII	79-80	HF
KZ	1000 ST	79-81	HF
KZ	1300	79-81	HF

SUZUKI			
GS	450	86-86	HF
GS	550	80-82	HF
GR	650	83-84	HF
GS	650	81-83	HF



SUZUKI			
GS	650 G	83-87	HF
GS	650 Turbo, XN	83-85	HF
GS	700	85-85	HF
GS	750	76-79	HF
GS	750 D	77-79	HF
GS	750 E	77-79	HF
GS	750 SD	83-83	HF
GS	850	79-82	HF
GS	850 G	83-86	HF
G	1000 SZ	82-82	HF
GS	1000	78-81	HF
GS	1000 ET	81-81	HF
GS	1000 EX	81-81	HF
GS	1100	81-83	HF
GS	1100 ED, ESD, GD	83-83	HF
GS	1100 G	86-88	HF
GS	1100 GKD, SD, GLD	83-83	HF
GS	1100 L	79-79	HF



SUZUKI			
GT	1100	80-80	HF
GV	1200 GLG Madura	86-86	HF
GV	1400 Cavalcade	85-86	HF

### SBS 513 Recommended compound



HARLEY DAVIDSON			
FXE	Series	74-77	H.HF
XLCH	1000	73-73	H.HF
FL	1200 FLH Police	75-79	H.HF H.HF
FLH	1200	74-76	H.HF H.HF
FLH	1200	80-80	H.HF
FLH	1200 Anniversary	78-78	H.HF H.HF
FLH	1200 Touring	77-78	H.HF H.HF
FLHS	1200	77-80	H.HF
FX	1200	74-80	H.HF
FXE	1200	74-80	H.HF
FXS	1200	78-79	H.HF
FLH	1340 80	78-81	H.HF H.HF
FLH	1340 80	81-81	H.HF
FLH	1340 Electra Glide	82-83	H.HF
FLH	1340 Electra Glide Spec.	84-84	H.HF
FXB	1340 80	80-81	H.HF
FXB	1340 Sturgis	82-82	H.HF



HARLEY DAVIDSON			
FXE	1340 80	78-81	H.HF
FXE	1340 Super Glide	83-84	H.HF
FXEF	1340 80 Fat Bob	79-81	H.HF
FXR	1340	78-81	H.HF
FXS	1340 80	79-81	H.HF
FXS	1340 Low Rider	82-82	H.HF
FXWG	1340 80	80-81	H.HF
FXWG	1340 Wide Glide	82-82	H.HF

Brake Pad 1:1 Drawings, Compounds, Fitments

Available compounds

**HF**

**SBS 511**

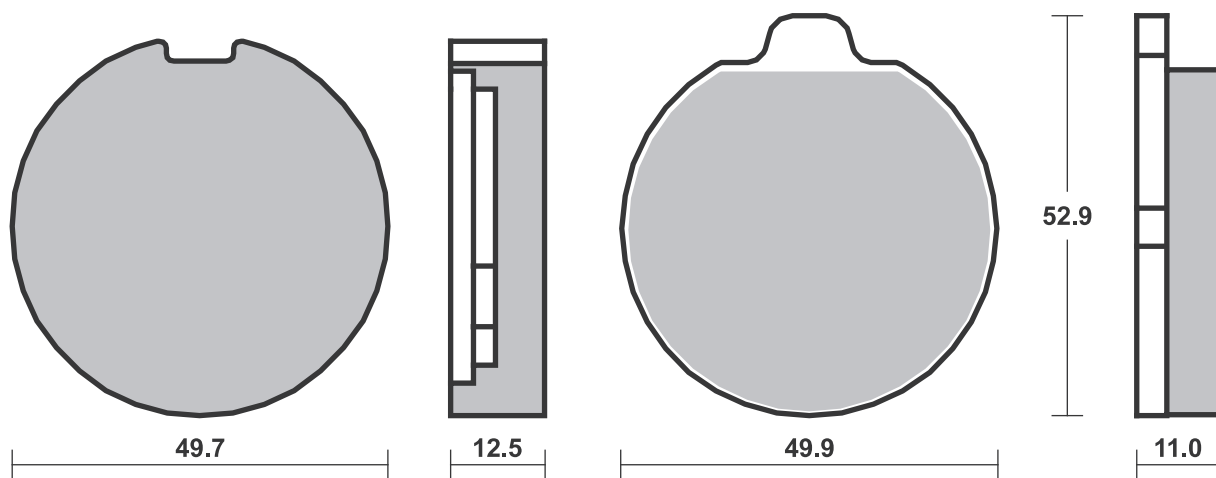

Available compounds

**HF • H.HF • H.CT**

**SBS 512**

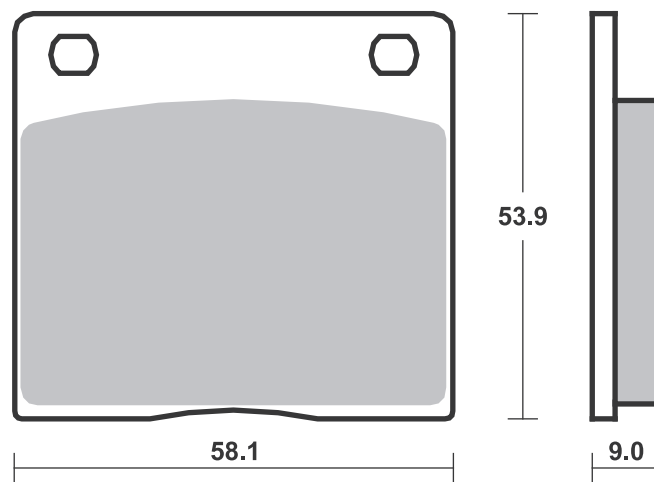

Available compounds

**H.HF • H.CT**

**SBS 513**

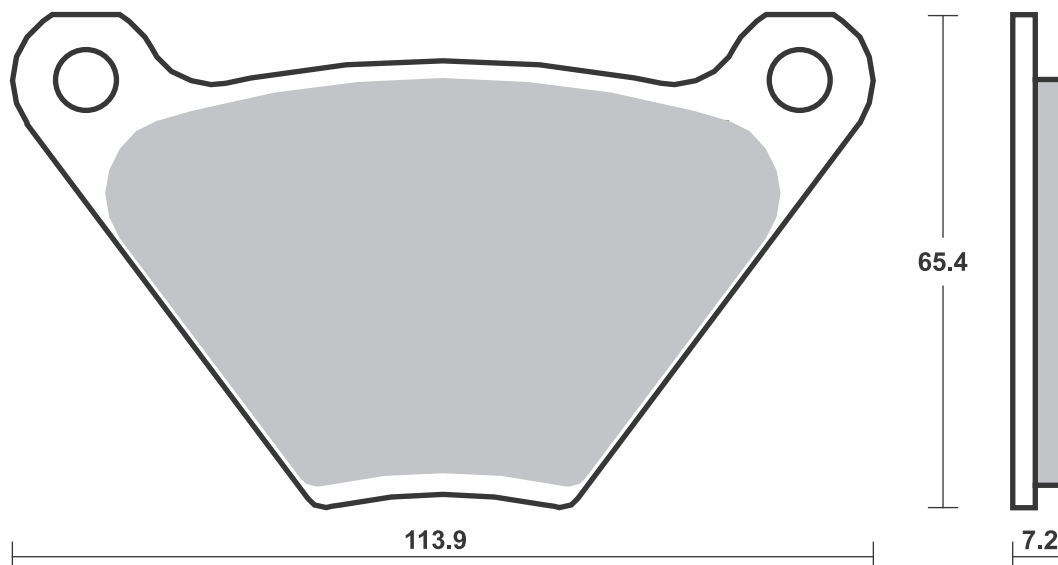



Available compounds

HF

SBS 514

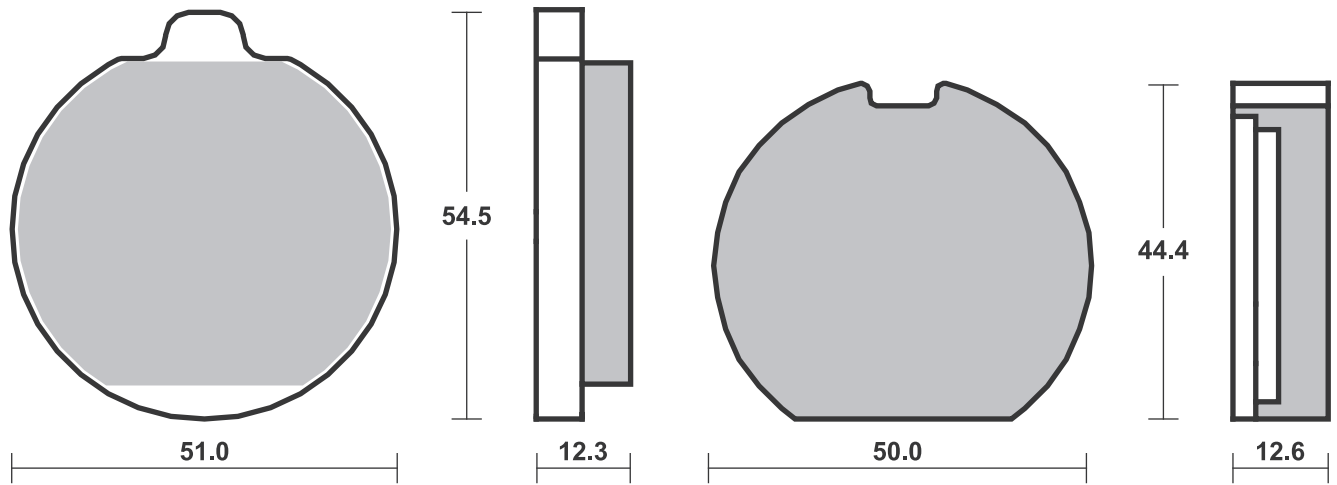

Available compounds

HF

SBS 515

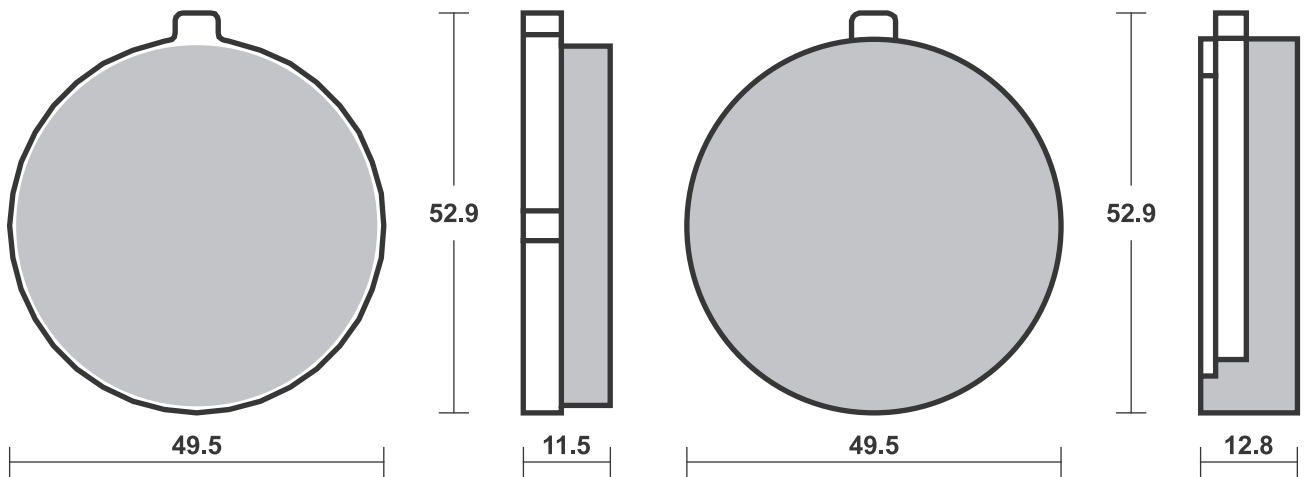

Available compounds

HF

SBS 516

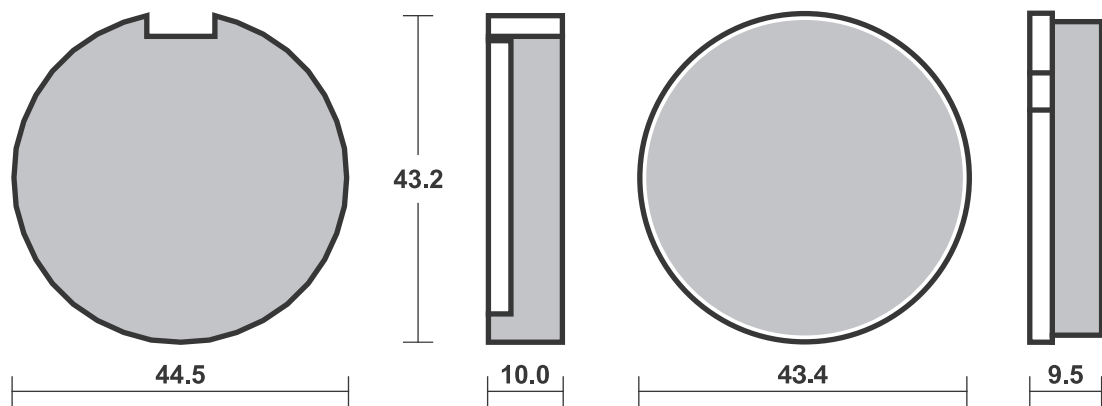



<b>HONDA</b>			
MT	125 R	78-78	<b>HF</b>
CX	500	78-80	<b>HF</b>
CB	750 F	77-80	<b>HF</b>
CB	750 SS	77-79	<b>HF</b>
CB	900 F	78-80	<b>HF</b>
CBX	1000	78-80	<b>HF</b>
GL	1000 Gold Wing	81-81	<b>HF</b>
GL	1000 Gr. Tour.		
	Gold Wing	81-82	<b>HF</b>
GL	1000 K3 Gold Wing	78-79	<b>HF</b>
GL	1100 A Gold Wing	79-83	<b>HF</b>



<b>APRILIA</b>			
RS	250 Pista	04-04	<b>HF</b>
<b>ARMSTRONG</b>			
MX	500	86-86	<b>SI</b>
MX	600	86-86	<b>SI</b>
<b>BENELLI</b>			
	654 Sport	83-83	<b>HF</b>
	900 Tornado 3	00-06	<b>LS</b>
TnT	1100	04-04	<b>LS</b>
<b>BETA</b>			
ALP	240	96-96	<b>RSI</b>
ALP	260	96-96	<b>RSI</b>
	500 GS, RV	84-84	<b>HF</b>
<b>BIMOTA</b>			
YB7	400	89-89	<b>HF</b>
	500 Vdue	97-00	<b>HF</b>
	600 Bellaria	91-91	<b>HF</b>
YB9	600 SRI	97-97	<b>HF</b>
BB1	650 Supermono	97-00	<b>HF</b>
SB7	750	96-88	<b>HF</b>
YB4	750	89-89	<b>HF</b>
1D	851 Tesi	91-91	<b>HF</b>
1D	900 Tesi	93-93	<b>HF</b>
DB2	900	92-00	<b>HF</b>
DB3	900 Mantra	97-00	<b>HF</b>
DB4	900	99-00	<b>LS</b>
1D	906 Tesi	91-91	<b>HF</b>
	1000 Furano	92-93	<b>HF</b>
2D	1000 Tesi	04-06	<b>LS</b>
SB8	1000 R	98-00	<b>LS</b>
SB8K	1000	06-06	<b>LS</b>
SB8K	1000 Santamonica	07-09	<b>LS</b>
YB11	1000	97-00	<b>HF</b>
YB6	1000	89-89	<b>HF</b>
YB8	1000	90-90	<b>HF</b>
	1002 Dieci	91-91	<b>HF</b>
DB7	1099	09-09	<b>LS</b>
SB6	1100	97-00	<b>HF</b>



<b>BREMBO RACING CALIPERS</b>			
	Goldline 20.5161.42/51, road		
<b>CAGIVA</b>			
	125 Blues	87-85	<b>HF</b>
	125 Blues	93-93	<b>HF</b>
	125 Cruiser	88-88	<b>HF</b>
	125 Enduro	86-86	<b>HF</b>
	125 Raptor	03-10	<b>HF</b>
WMX	125 GP-Replica	86-89	<b>SI</b>
WRX	125	85-85	<b>HF</b>
	200 Elefant	86-86	<b>HF</b>
MXR	250	82-82	<b>HF</b>
WMX	250 GP	82-82	<b>SI</b>
	350 Alazzurra	85-87	<b>HF</b>
	350 Elefant	86-89	<b>HF</b>
T4	350 R	87-99	<b>HF</b>
	500 Mito	07-07	<b>LS</b>
T4	500 E	87-90	<b>HF</b>
WMX	500	85-86	<b>SI</b>
WMX	500 Cross	87-87	<b>SI</b>
SP	525 Mito	08-10	<b>LS</b>
	650 Alazzurra	84-84	<b>HF</b>
	650 Elefant	86-87	<b>HF</b>
<b>CAN-AM</b>			
	200 ASE	86-86	<b>SI</b>
	250 ASE	86-86	<b>SI</b>
	250 MX LC	86-86	<b>SI</b>
	350 ASE	86-86	<b>SI</b>
	406 ASE	87-87	<b>SI</b>
	500 ASE	86-86	<b>SI</b>
	500 MX	86-86	<b>SI</b>
	560 Sonic	86-14	<b>SI</b>
<b>DERBI</b>			
	125 Mulhacen	07-07	<b>HF</b>
	125 Terra	07-07	<b>HF</b>
	250 RC	85-85	<b>HF</b>
<b>DUCATI</b>			
	350	75-78	<b>HF</b>
	350 GTV	77-77	<b>HF</b>



<b>DUCATI</b>			
	350 Indiana	86-91	<b>HF</b>
	350 Paso	86-86	<b>HF</b>
	350 Sport	77-80	<b>HF</b>
	400 Monster		
	(Japan)	01-06	<b>LS</b>
	400 SS, Junior	92-97	<b>HF</b>
	400 SS, Nuda	92-96	<b>HF</b>
	500 GTV	77-82	<b>HF</b>
	500 Pantah	85-89	<b>HF</b>
	500 Sport Desmo	77-82	<b>HF</b>
	500 Twin GTL	75-80	<b>HF</b>
	502 Single	93-93	<b>HF</b>
	502 Supermono	93-93	<b>HF</b>
	600 Monster	00-01	<b>LS</b>
	600 SL, TL Pantah	76-89	<b>HF</b>
	600 SS Supersport	95-00	<b>HF</b>
M	600 Monster	94-99	<b>HF</b>
	620 Monster		
	Dark i.e.	02-06	<b>LS</b>
	620 Monster i.e.,		
	s i.e.	02-06	<b>LS</b>
	650 Indiana	86-89	<b>HF</b>
	695 Monster	07-12	<b>LS</b>
	748 , S	99-02	<b>LS</b>
	748 Biposto	95-98	<b>HF</b>
	748 R	00-02	<b>LS</b>
	748 SP	95-97	<b>HF</b>
	748 SPS	98-99	<b>LS</b>
	750 Indiana	85-86	<b>HF</b>
	750 Monster	96-99	<b>HF</b>
	750 Monster	00-01	<b>LS</b>
	750 Monster i.e.	02-02	<b>LS</b>
	750 Paso	86-88	<b>HF</b>
	750 SS Supersport	95-99	<b>HF</b>
	750 SS, Carenara	92-98	<b>HF</b>
	750 SS, Nuda	92-92	<b>HF</b>
	750 Super Sport	92-94	<b>HF</b>
	800 Monster		
	Dark i.e., s i.e.	03-07	<b>LS</b>
	800 Monster i.e.,		
	s i.e.	03-07	<b>LS</b>
	803 Monster S2R	05-07	<b>LS</b>



Available compounds

HF • DCC

SBS 517

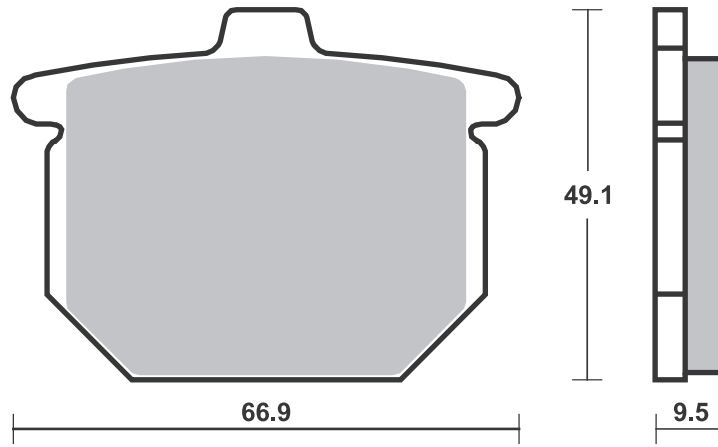

Available compounds

HF • LS • DCC • RQ • SI • RSI

SBS 519

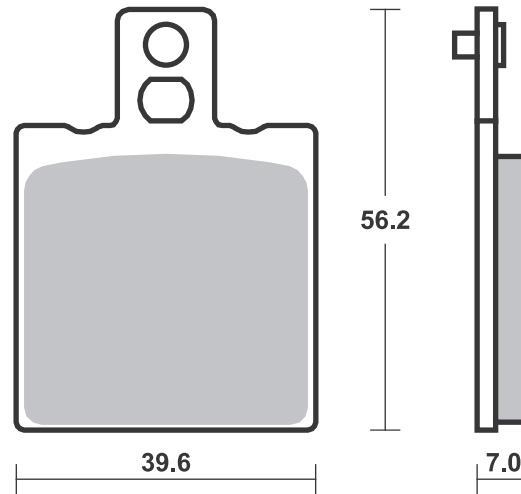



<b>DUCATI</b>			
803 Monster			
S2R ABS	05-07	<b>LS</b>	
851 Strada	89-89	<b>HF</b>	
851 Superbike	90-90	<b>HF</b>	
888 SP V	93-93	<b>HF</b>	
888 SP4	92-95	<b>HF</b>	
888 SPO	93-93	<b>HF</b>	
888 SPS	92-95	<b>HF</b>	
888 Strada	93-93	<b>HF</b>	
888 Superbike	93-93	<b>HF</b>	
900 FE	97-98	<b>HF</b>	
900 M, IL Monster	93-99	<b>HF</b>	
900 Monster	00-01	<b>LS</b>	
900 Monster i.e.	02-02	<b>LS</b>	
900 SL	92-97	<b>HF</b>	
900 SS	90-94	<b>HF</b>	
900 SS Supersport	95-97	<b>HF</b>	
900 SSR	92-92	<b>HF</b>	
906 900 Paso	89-89	<b>HF</b>	
907 900 I. E.	90-93	<b>HF</b>	
M 900 Street Monster	94-99	<b>HF</b>	
MH 900	00-01	<b>LS</b>	
916 Biposto	94-98	<b>HF</b>	
916 Monster S4	01-03	<b>LS</b>	
916 SPS	97-98	<b>LS</b>	
996 , SPS	99-01	<b>LS</b>	
996 Monster S4R	04-06	<b>LS</b>	
996 R	01-01	<b>LS</b>	
996 RS			
(slipper clutch)	00-01	<b>LS</b>	
996 S	01-01	<b>LS</b>	
998 , S	02-04	<b>LS</b>	
998 R	02-04	<b>LS</b>	
998 RS			
(slipper clutch)	02-03	<b>LS</b>	
1000 Monster			
Dark i.e., s.i.e.	03-06	<b>LS</b>	
1000 Monster i.e., s.i.e.	03-06	<b>LS</b>	
<b>FANTIC</b>			
250 Coach	91-98	<b>HF</b>	
<b>GILERA</b>			
50 Sioux	92-92	<b>HF</b>	<b>HF</b>
125 Arizona Hawk	86-89	<b>HF</b>	
125 Crono	92-95	<b>HF</b>	
125 Freestyle	92-95	<b>HF</b>	
125 HX, HE	83-83	<b>HF</b>	
125 KK, KR, KZ	86-91	<b>HF</b>	
125 MX1, MRX, SP01	89-93	<b>HF</b>	
125 R1, R1S	90-92	<b>HF</b>	
125 SP02	90-94	<b>HF</b>	
CX 125	91-95	<b>HF</b>	
MXR 125	90-90	<b>HF</b>	
200 RX	83-83	<b>HF</b>	
250 Arizona Hawk	86-91	<b>HF</b>	
250 Arizona Rally	86-91	<b>HF</b>	
250 Arizona Rally	08-08	<b>HF</b>	
NGR 250	85-85	<b>HF</b>	
350 Saturno			
Bialbero	90-90	<b>HF</b>	
XRT 350	90-90	<b>HF</b>	
500 Saturno			
Bialbero	90-90	<b>HF</b>	
500 Saturno Piuma	90-94	<b>HF</b>	



<b>GILERA</b>			
600 Nordwest	91-94	<b>HF</b>	
RC 600	88-88	<b>HF</b>	
XRT 600	89-89	<b>HF</b>	
<b>HUSQVARNA</b>			
CR 125	85-90	<b>SI</b>	
CX 125	84-85	<b>SI</b>	
200 Prof	86-86	<b>SI</b>	<b>SI</b>
CR 240	84-85	<b>SI</b>	
CR 250	85-87	<b>SI</b>	
CX 250	84-85	<b>SI</b>	
400 Enduro	85-88	<b>SI</b>	
430 Enduro	85-88	<b>SI</b>	
CR 500	86-87	<b>SI</b>	
CX/CR 500	84-85	<b>SI</b>	
TC 500	86-86	<b>SI</b>	
504	83-83	<b>SI</b>	
TE 510	86-87	<b>SI</b>	
<b>ISR CALIPERS</b>			
2 Piston (22-027/028/029)			
4 Piston (22-025)			
<b>ITALJET</b>			
350	83-83	<b>HF</b>	
<b>KEEWAY</b>			
125 Enduro	07-08	<b>HF</b>	
125 X-Ray	07-08	<b>HF</b>	
<b>KTM</b>			
LC 125	85-85	<b>SI</b>	
LC 125	86-86	<b>SI</b>	<b>SI</b>
MX 125	85-85	<b>SI</b>	
MX 125	86-86	<b>SI</b>	<b>SI</b>
XC 125	85-85	<b>SI</b>	
XC 125	86-89	<b>SI</b>	<b>SI</b>
250 Baja	86-89	<b>SI</b>	
250 Country,Baja	85-85	<b>SI</b>	
LC 250	85-85	<b>SI</b>	
LC 250	86-86	<b>SI</b>	<b>SI</b>
MC 250	83-84	<b>SI</b>	<b>SI</b>
MX 250	85-85	<b>SI</b>	
XC 250	85-85	<b>SI</b>	
XC 250	86-89	<b>SI</b>	<b>SI</b>
XC 300	85-85	<b>SI</b>	
XC 300	86-90	<b>SI</b>	<b>SI</b>
350 Country Cross	85-85	<b>SI</b>	
350 GS	83-85	<b>SI</b>	
GS4 350 500 K4	82-83	<b>SI</b>	
K4 350 500 K4	82-83	<b>SI</b>	
XC 350 , MC	81-83	<b>SI</b>	
390 GS	83-83	<b>SI</b>	
XC 390 , MC	81-83	<b>SI</b>	
MC 495 Leleu	82-83	<b>SI</b>	
MX 495 Leleu	82-83	<b>SI</b>	
GS 500 500 K4 Enduro	83-83	<b>SI</b>	
LC 500	85-85	<b>SI</b>	
LC 500	86-89	<b>SI</b>	<b>SI</b>
MX 500	85-85	<b>SI</b>	
MX 500	86-86	<b>SI</b>	<b>SI</b>
XC 500 , MC	81-83	<b>SI</b>	
4T 600 Enduro	84-86	<b>SI</b>	
GS 600	85-85	<b>SI</b>	
XC 600 Cross	85-85	<b>SI</b>	
XCE 600 Cross	85-85	<b>SI</b>	



<b>KTM</b>			
620 Duke	96-98	<b>HF</b>	
640 Duke	99-02	<b>HF</b>	
<b>LAVERDA</b>			
GS 350 Lesmo	86-89	<b>HF</b>	<b>HF</b>
500 Alpino, S	77-83	<b>HF</b>	<b>HF</b>
OR 600 Atlas	86-90	<b>HF</b>	
650	92-92	<b>HF</b>	
668 668	96-97	<b>HF</b>	
668 Ghost,			
Diamante	97-97	<b>HF</b>	
750 Cup	98-01	<b>HF</b>	
750 Diamante	97-01	<b>HF</b>	
750 Ghost Strike	97-01	<b>HF</b>	
750 S Formula	97-01	<b>HF</b>	
750 S, S Carenata	97-01	<b>HF</b>	
750 Sport	99-01	<b>HF</b>	
750 Strike/			
Black Strike	99-01	<b>HF</b>	
750 T8	98-01	<b>HF</b>	
JOTA 1000	95-95	<b>HF</b>	
<b>MAICO</b>			
GM 250 LC	85-85	<b>SI</b>	
MD 250	83-85	<b>SI</b>	<b>SI</b>
GM 500 LC	85-86	<b>SI</b>	
<b>MALAGUTI</b>			
50 Enduro	85-87	<b>HF</b>	
MRX 50	89-89	<b>HF</b>	
RST 50	90-90	<b>HF</b>	<b>HF</b>
<b>MOTO-GUZZI</b>			
125 Custom	85-85	<b>HF</b>	
125 Enduro TT	85-85	<b>HF</b>	
BX 125	92-92	<b>HF</b>	<b>HF</b>
240 /4	77-77	<b>HF</b>	
250 TS	75-76	<b>HF</b>	
350	77-81	<b>HF</b>	<b>HF</b>
350 Falco	88-88	<b>HF</b>	<b>HF</b>
350 Imola	78-84	<b>HF</b>	<b>HF</b>
350 Nevada	92-97	<b>HF</b>	
NTX 350	88-88	<b>HF</b>	<b>HF</b>
NTX 350	90-90	<b>HF</b>	
V35 350 C	82-86	<b>HF</b>	
V35 350 Florida	85-86	<b>HF</b>	
V35 350 GT	77-77	<b>HF</b>	
V35 350 GT	90-90	<b>HF</b>	
V35 350 II, Imola,			
Imola II	77-77	<b>HF</b>	<b>HF</b>
400	77-84	<b>HF</b>	<b>HF</b>
500	77-80	<b>HF</b>	<b>HF</b>
500 Monza	78-85	<b>HF</b>	<b>HF</b>
V50 500 1,2,3,			
Monza Chopper	77-77	<b>HF</b>	<b>HF</b>
650	80-84	<b>HF</b>	<b>HF</b>
650 Florida	85-84	<b>HF</b>	<b>HF</b>
GT 650 Sessantacinque	89-89	<b>HF</b>	<b>HF</b>
NTX 650	90-02	<b>HF</b>	
V65 650 Lario	86-94	<b>HF</b>	<b>HF</b>
V65 650 NTX	87-02	<b>HF</b>	<b>HF</b>
V65 650 SP, Chopper	80-84	<b>HF</b>	<b>HF</b>
V65 650 TT	86-94	<b>HF</b>	<b>HF</b>
750 Ippogrifo	97-97	<b>HF</b>	
750 Nevada	92-96	<b>HF</b>	
750 Nevada,			
Club/Base	97-02	<b>HF</b>	<b>HF</b>

Available compounds

**HF • LS • DCC • RQ • SI • RSI**

**SBS 519**

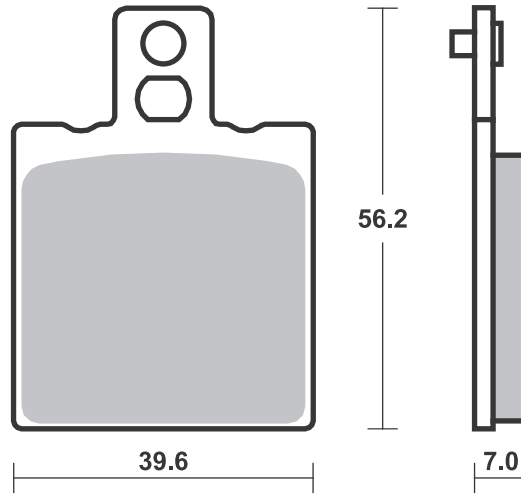

**Applications**

**SBS 519 Recommended compound**



<b>MOTO-GUZZI</b>			
	750 Targa	89-89	<b>HF HF</b>
NTX	750	89-89	<b>HF HF</b>
RS	1000 Daytona	97-00	<b>HF</b>
V	1000 Strada	93-94	<b>HF</b>
V10	1000 Centauro	96-00	<b>HF</b>
	1100 Sport	96-04	<b>HF</b>
EV	1100 California	97-00	<b>HF</b>
EV	1100 California, 80, Touring	01-01	<b>LS</b>
V11	1100 , Scura, Sport Scura	02-05	<b>LS</b>
V11	1100 Lemans, Lemans Tenni, Lemans Rosso		
	Corsa	01-06	<b>LS</b>
V11	1100 Sport	97-00	<b>HF</b>
V11	1100 Sport Rosso		
	Mandell	01-06	<b>LS</b>
V11	1100 Sport, Sport Naked	01-05	<b>LS</b>
<b>MOTO-MORINI</b>			
XE	250 Country	88-88	<b>HF</b>
	350 Coguaro	90-95	<b>HF</b>
	350 Coguaro, New York	90-94	<b>HF</b>
	350 Dart	88-88	<b>HF</b>
	350 Dart	90-92	<b>HF</b>
	350 Indiana	88-88	<b>HF</b>
	350 Kanguro	88-88	<b>HF</b>
RLX	350 Excalibur	90-92	<b>HF</b>
	400 Dart	89-92	<b>HF</b>

<b>MOTO-MORINI</b>			
	400 S	82-82	<b>HF HF</b>
	500 Sei V Classic	89-89	<b>HF</b>
	501 Camel	88-88	<b>HF</b>
	501 Coguaro	89-89	<b>HF</b>
	501 New York	89-89	<b>HF</b>
RLX	501 Excalibur	88-89	<b>HF</b>
RLX	501 Excalibur	90-90	<b>HF</b>
	650 Indiana	88-88	<b>HF</b>
	750 Indiana	88-88	<b>HF</b>
<b>MZ</b>			
	660 (MUZ)		
	Skorpion Cup	99-99	<b>HF</b>
	660 (MUZ)		
	Skorpion		
	Replica	97-99	<b>HF</b>
	660 (MUZ)		
	Skorpion Sport	95-99	<b>HF</b>
	660 (MUZ)		
	Skorpion Tour	95-00	<b>HF</b>
	660 (MUZ)		
	Skorpion		
	Traveller	99-00	<b>HF</b>
<b>REWACO</b>			
	FX4	07-07	<b>HF</b>
	FX5	07-07	<b>HF</b>
	FX6	07-07	<b>HF</b>
	HS4	01-01	<b>HF</b>
	HS5	01-01	<b>HF</b>
	HS6	01-01	<b>HF</b>
	RF1	07-14	<b>HF</b>

**SBS 520 Recommended compound**



<b>BMW</b>			
R60/7	600	76-77	<b>HF</b>
R75/6	750	74-76	<b>HF</b>
R75/7	750	76-77	<b>HF</b>
R80/7	800	77-81	<b>HF</b>
R90	900 S	73-76	<b>HF</b>
R90/6	900	73-76	<b>HF</b>
R100	1000 RS	76-80	<b>HF</b>
R100	1000 S	76-80	<b>HF</b>
R100	1000 T	79-84	<b>HF</b>
R100/7	1000	78-80	<b>HF</b>

Brake Pad 1:1 Drawings,  
Compounds, Fitments

Available compounds

HF • LS • DCC • RQ • SI • RSI

SBS 519

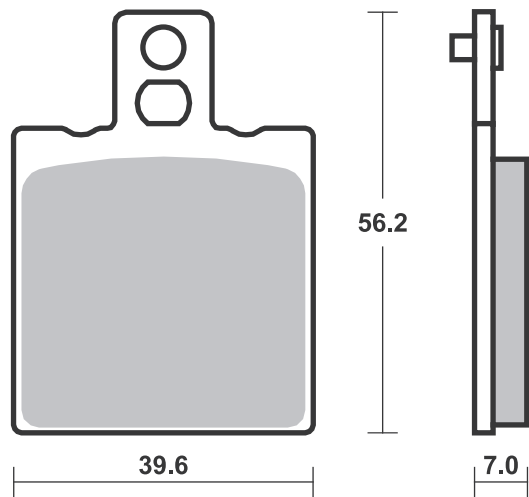

Available compounds

HF

SBS 520

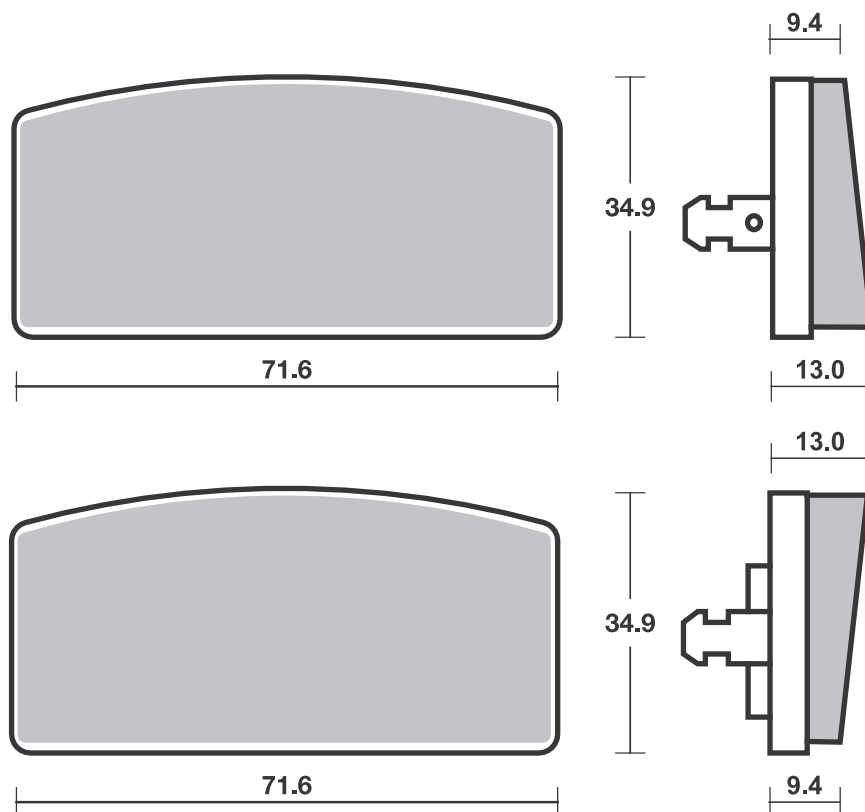

Dimensions in mm / Dimensions en mm • 1" = 25.4 mm , 1 mm = 0.04"



Available compounds

HF

SBS 522

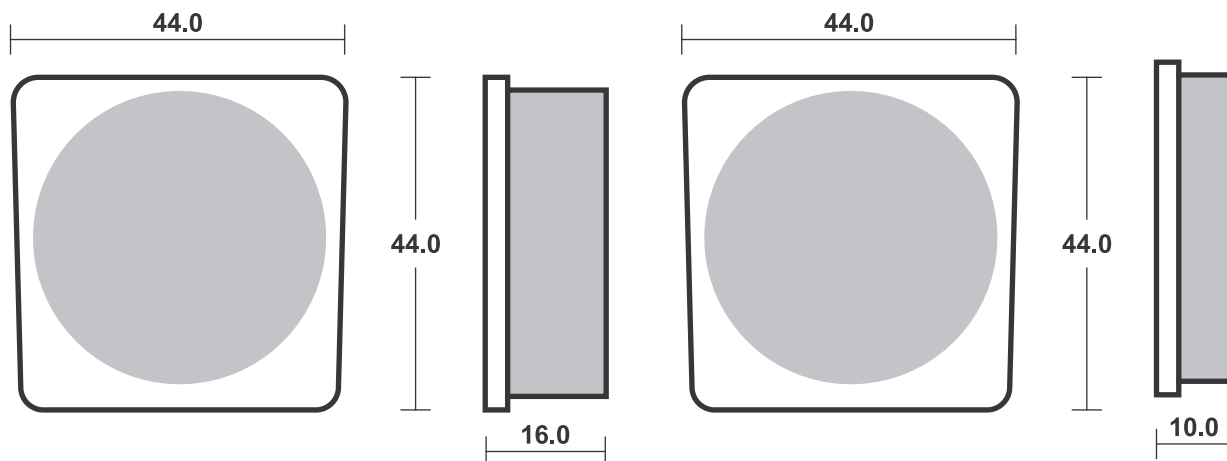

Available compounds

HF • DC • DCC

SBS 523

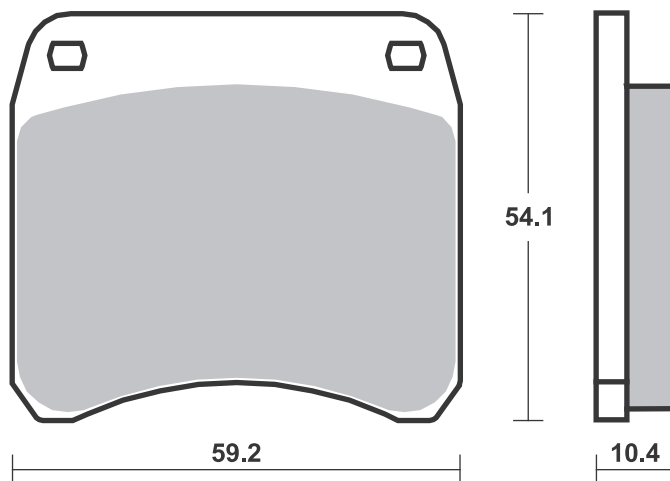

Available compounds

HF

SBS 524

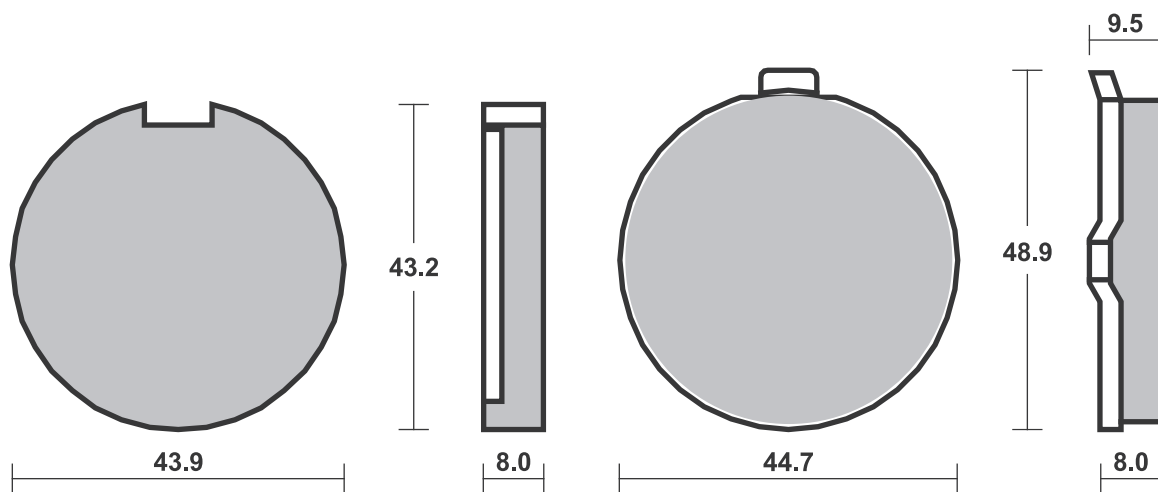





Available compounds

HF

SBS 525

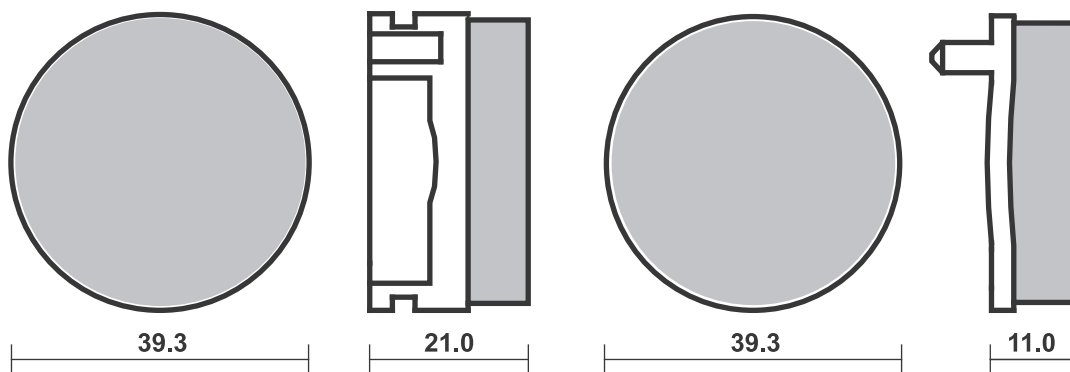

Available compounds

HF • DCC

SBS 526

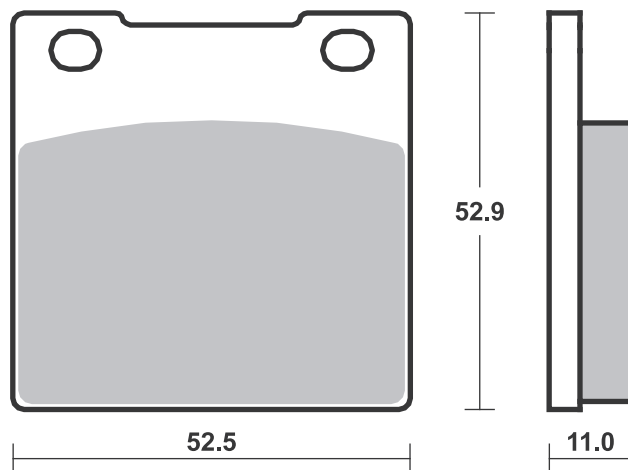

Available compounds

HF

SBS 527

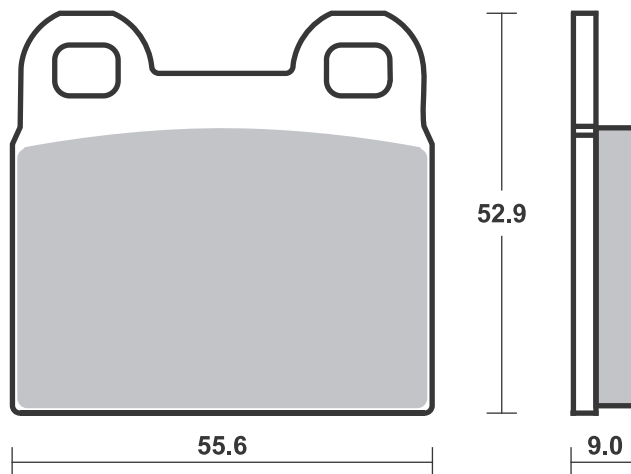



Available compounds

HF

SBS 528

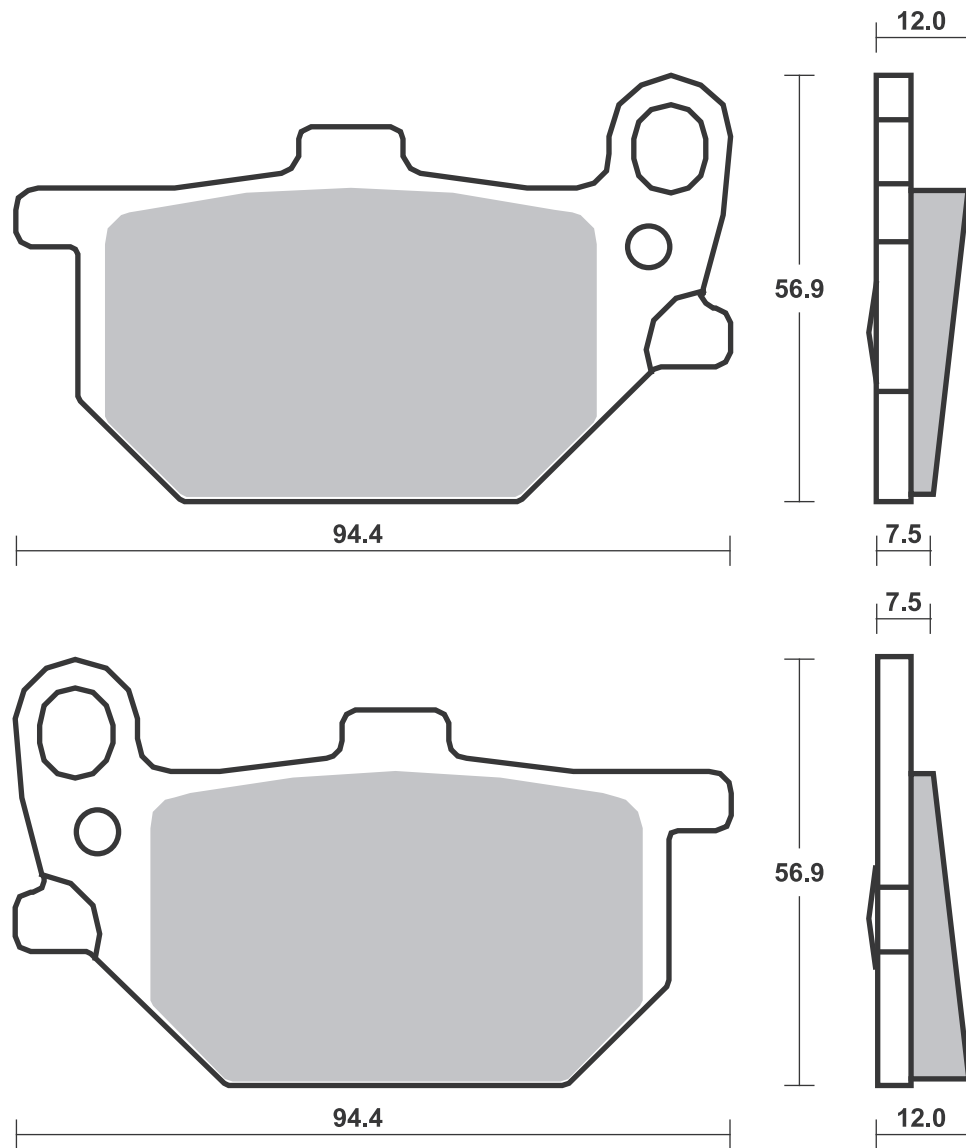

Available compounds

HF

SBS 530

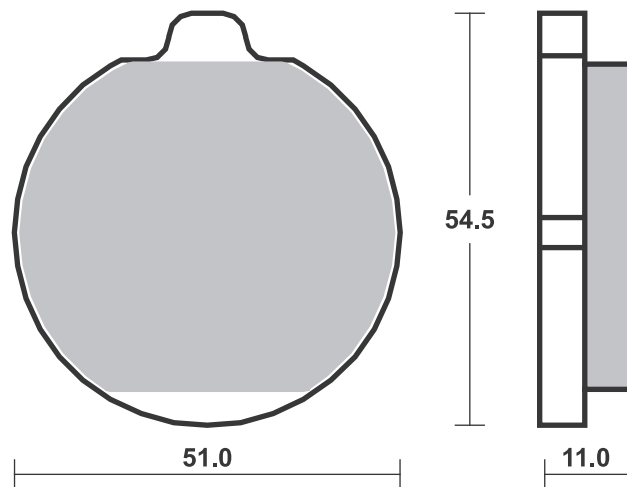



Available compounds

HF

SBS 532

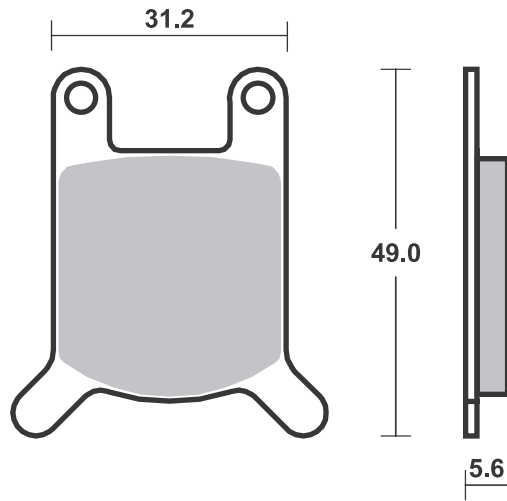

Available compounds

HF

SBS 533

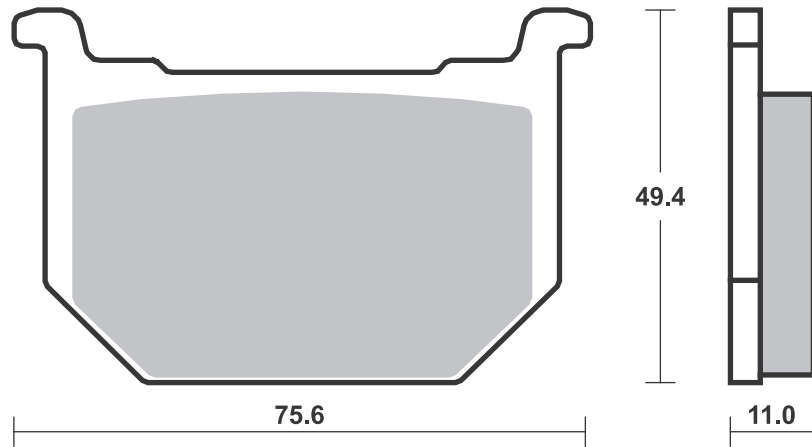



Available compounds

HF • DCC

SBS 534

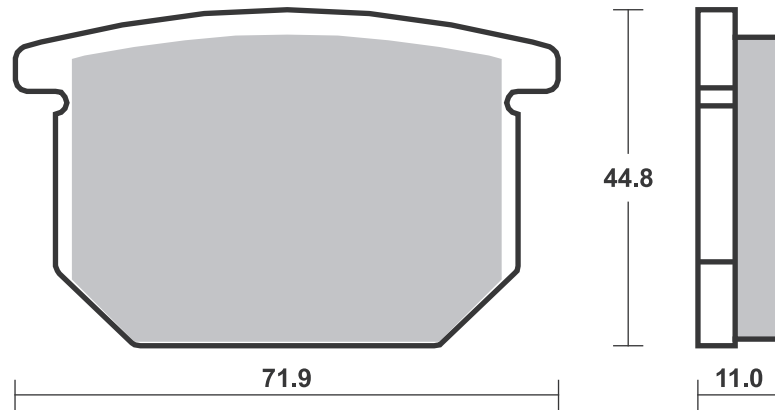

Available compounds

HF • SI • RSI

SBS 536

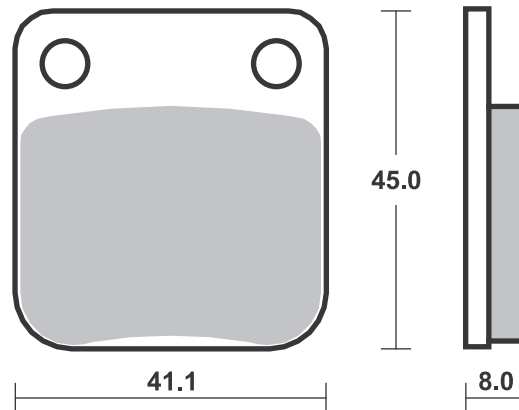

**SBS 537** Recommended compound

<b>HARLEY DAVIDSON</b>		
XLH 883	70-83	<b>H.HF</b>
XL 1000	78-78	<b>H.HF</b>
XLCH 1000	78-80	<b>H.HF</b>
XLH 1000 Sportster	79-85	<b>H.HF</b>
XLS 1000 Anniversary	82-82	<b>H.HF</b>
XLS 1000 Roadster	79-82	<b>H.HF</b>
XLS 1000 Sportster	83-83	<b>H.HF</b>
XLX 1000 61	83-84	<b>H.HF</b>
XR 1000	85-85	<b>H.HF</b>
FX 1200	74-80	<b>H.HF</b>
FXE 1200	74-80	<b>H.HF</b>
FXS 1200	78-79	<b>H.HF</b>
FLHT 1340 Tour Glide	84-84	<b>H.HF</b>
FXB 1340 80	80-81	<b>H.HF</b>
FXB 1340 Sturgis	82-82	<b>H.HF</b>
FXE 1340	82-82	<b>H.HF</b>
FXE 1340 80	78-81	<b>H.HF</b>



<b>HARLEY DAVIDSON</b>		
FXE 1340 Super Glide	83-84	<b>H.HF</b>
FXEF 1340 80 Fat Bob	79-81	<b>H.HF</b>
FXR 1340	78-81	<b>H.HF</b>
FXR 1340 Super Glide	82-83	<b>H.HF</b>
FXRS 1340 Low Glide	82-84	<b>H.HF</b>
FXRS 1340 Super Glide II	82-83	<b>H.HF</b>
FXRT 1340 Super Glide II	83-83	<b>H.HF</b>
FXS 1340 80	79-81	<b>H.HF</b>
FXS 1340 Low Rider	82-82	<b>H.HF</b>
FXSB 1340 Low Rider	83-83	<b>H.HF</b>
FXWG 1340 80	80-81	<b>H.HF</b>
FXWG 1340 Wide Glide	83-84	<b>H.HF</b>

**SBS 539** Recommended compound

<b>KAWASAKI</b>		
KZ 440 H	82-84	<b>HF</b>
KZ 650	81-84	<b>HF</b>
KZ 650 F	81-84	<b>HF</b>
KZ 700	83-88	<b>HF</b>
GPZ 750	82-82	<b>HF</b>
KZ 750	84-86	<b>HF</b>
KZ 750 , LTD	80-81	<b>HF</b>
KZ 750 E	80-81	<b>HF</b>
KZ 750 GT	82-85	<b>HF</b>
KZ 750 L	80-82	<b>HF</b>
KZ 750 LTD Belt Drive	83-85	<b>HF</b>
KZ 750 LTD Twin	82-82	<b>HF</b>
KZ 750 Sp.	83-84	<b>HF</b>
KZ 750 Y1, N, LTD	82-85	<b>HF</b>
KZ 1000	87-01	<b>HF</b>



<b>KAWASAKI</b>		
KZ 1000 F1	80-82	<b>HF</b>
KZ 1000 J	79-83	<b>HF</b>
KZ 1000 K, M, CSR	81-84	<b>HF</b>
KZ 1000 LTD	81-84	<b>HF</b>
KZ 1000 MKII	79-80	<b>HF</b>
KZ 1000 Police	82-01	<b>HF</b>
KZ 1000 ST	79-81	<b>HF</b>
GPZ 1100	81-82	<b>HF</b>
KZ 1100 , Spectre	82-83	<b>HF</b>
KZ 1100 GP	81-81	<b>HF</b>
KZ 1100 L1, LTD	83-83	<b>HF</b>

**SBS 540** Recommended compound

<b>KAWASAKI</b>		
KZ 305	81-88	<b>HF</b>
KZ 440	83-83	<b>HF</b>
KZ 440 , LTD	83-85	<b>HF</b>
KZ 440 C, Twin	81-83	<b>HF</b>
KZ 440 H	82-84	<b>HF</b>
KZ 550	81-83	<b>HF</b>
KZ 650 , CSR	81-82	<b>HF</b>
KZ 700	83-88	<b>HF</b>
GPZ 750	82-82	<b>HF</b>
KZ 750	84-86	<b>HF</b>
KZ 750 , LTD	80-81	<b>HF</b>
KZ 750 E	80-81	<b>HF</b>
KZ 750 GT	82-85	<b>HF</b>
KZ 750 L	80-82	<b>HF</b>
KZ 750 L	84-86	<b>HF</b>
KZ 750 L3	83-83	<b>HF</b>
KZ 750 LTD Belt Drive	83-85	<b>HF</b>



<b>KAWASAKI</b>		
KZ 750 LTD Twin	82-82	<b>HF</b>
KZ 750 M1	82-85	<b>HF</b>
KZ 750 R1	82-82	<b>HF</b>
KZ 750 Sp.	83-84	<b>HF</b>
KZ 750 Y1, N, LTD	82-85	<b>HF</b>
Z 750	84-86	<b>HF</b>
KZ 1000	87-01	<b>HF</b>
KZ 1000 J	79-83	<b>HF</b>
KZ 1000 K, M, CSR	81-84	<b>HF</b>
KZ 1000 LTD	81-84	<b>HF</b>
KZ 1000 Police	82-01	<b>HF</b>
KZ 1000 RE1, R2	82-84	<b>HF</b>
GPZ 1100	81-82	<b>HF</b>
KZ 1100 , Spectre	82-83	<b>HF</b>
KZ 1100 GP	81-81	<b>HF</b>
KZ 1100 L1, LTD	83-83	<b>HF</b>



Available compounds

**H.HF • H.CT**

**SBS 537**

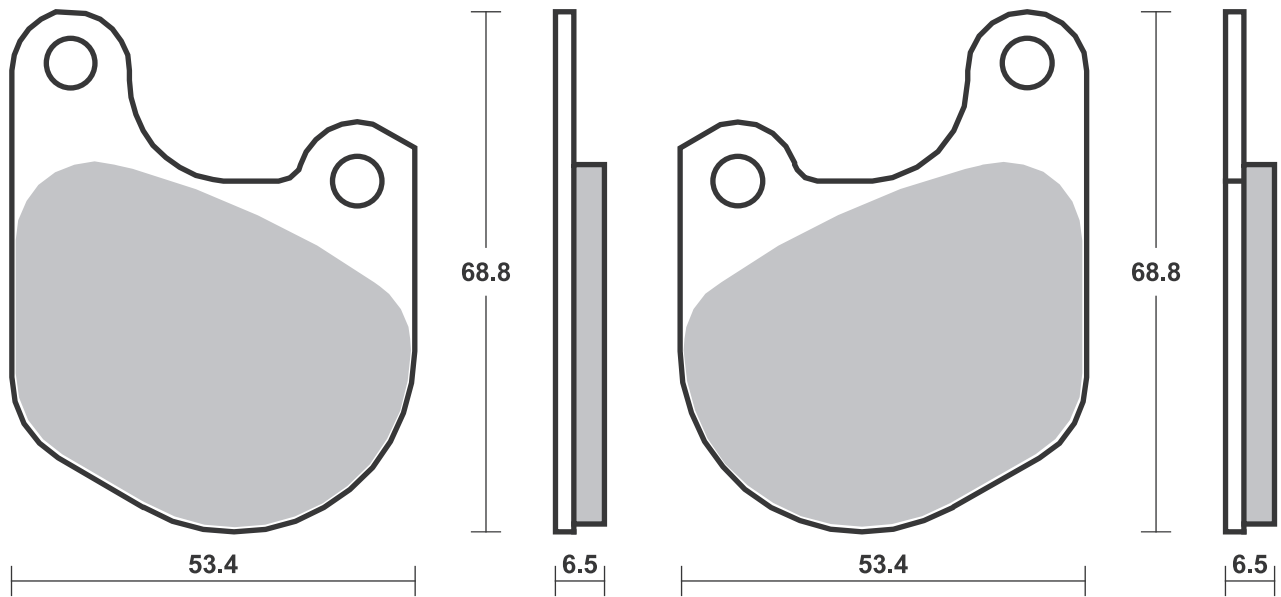

Available compounds

**HF • DCC**

**SBS 539**

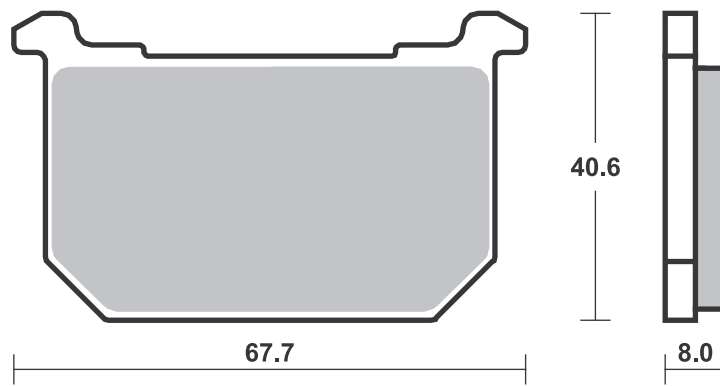

Available compounds

**HF**

**SBS 540**

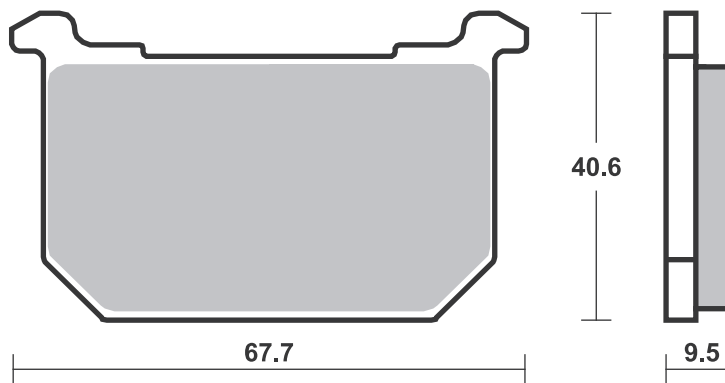



Available compounds

HF

SBS 541

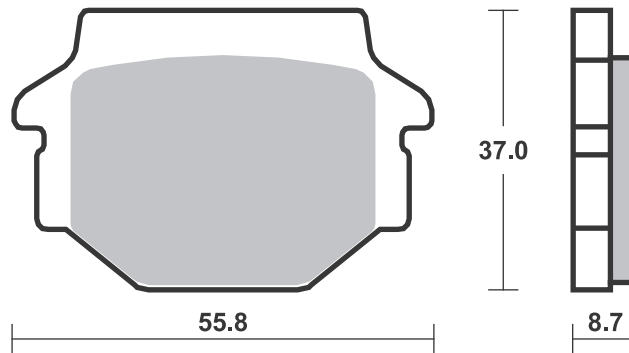
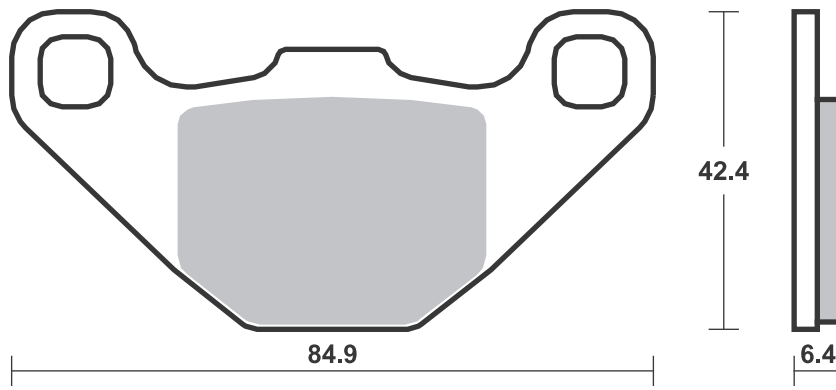

Available compounds

HF • HS • LS • DCC • RQ

SBS 542

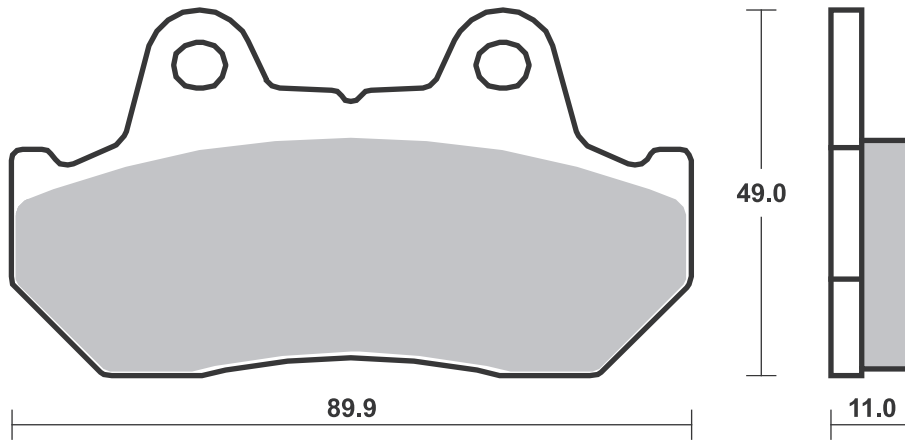



**HARLEY DAVIDSON**

XL	1000	78-78	<b>H.HF</b>
XLCH	1000	78-80	<b>H.HF</b>
XLH	1000 Sportster	79-82	<b>H.HF</b>
XLS	1000 Roadster	79-82	<b>H.HF</b>
FLH	1340 Classic	82-83	<b>H.HF</b>
FLH	1340 Electra Glide	82-83	<b>H.HF</b>
FLH	1340 Heritage	81-81	<b>H.HF</b>
FLT	1340 80	80-81	<b>H.HF</b>
FLT	1340 80 Classic	81-81	<b>H.HF</b>
FLT	1340 Classic	82-83	<b>H.HF</b>
FLT	1340 Tour Glide	82-82	<b>H.HF</b>

Brake Pad 1:1 Drawings,  
Compounds, Fitments

Available compounds

**H.HF • H.CT**

**SBS 543**

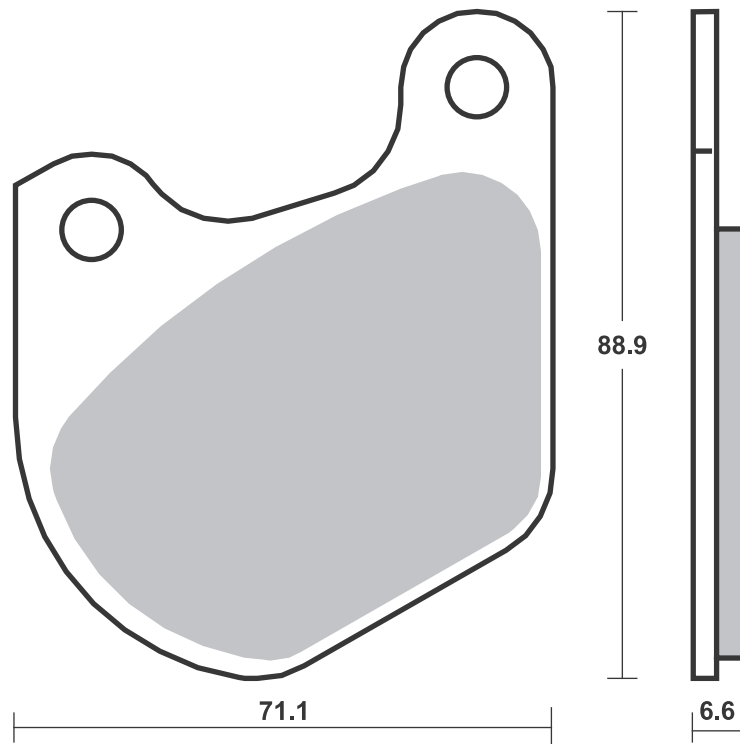
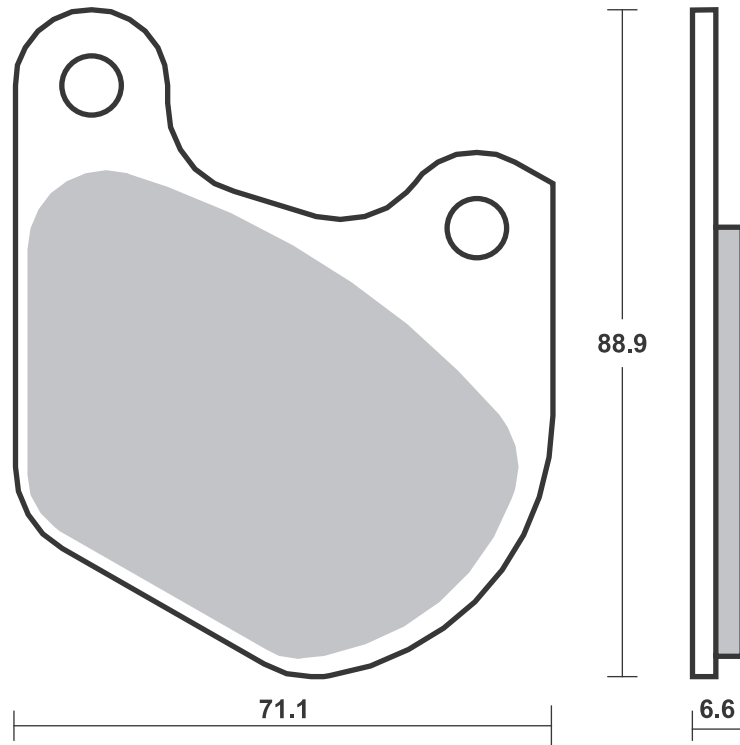



<b>ADLY</b>			
150 ATV	05-07	<b>SI</b>	<b>SI</b>
150 Interceptor	05-07	<b>SI</b>	<b>SI</b>
300 ATV	05-11	<b>SI</b>	<b>SI</b>

<b>APRILIA</b>			
125 Tuono ABS	17-19		<b>HF</b>
RS 125 GP	17-19		<b>HF</b>
RS-4 125 (J.Juan cal.)	11-19		<b>HF</b>
RS-4 125 Replica, ABS	16-19		<b>HF</b>

<b>BOMBARDIER</b>			
200 Rally 2x4	03-06	<b>SI</b>	

<b>CAN-AM</b>			
DS 90 X	08-18	<b>SI</b>	<b>SI</b>

<b>CECTEK</b>			
500 EFI Gladiator	09-13		<b>HF</b>
500 EFI King Cobra	09-13		<b>HF</b>
500 EFI Quadrift	09-11		<b>HF</b>
500 i Estoc	10-10		<b>HF</b>

<b>CPI</b>			
XS 250 Quad	06-08	<b>SI</b>	

<b>DERBI</b>			
DXR 200 Quad			
(Front disc)	04-07	<b>SI</b>	
DXR 250 Quad			
(Front disc)	04-07	<b>SI</b>	

<b>E-TON</b>			
VXL 250 Vector,			
ST Vector	06-07	<b>SI</b>	
VTX 300 Vortex,			
ST Vortex	07-07	<b>SI</b>	
VXL 300 Vector,			
ST Vector	07-13	<b>SI</b>	

<b>HYOSUNG</b>			
GD 125 EXIV	12-16		<b>HF</b>

<b>KAWASAKI</b>			
AR 50	81-82		<b>HF</b>
KD 80	88-90		<b>HF</b>
KX 80	84-87	<b>SI</b>	
KX 80	88-96	<b>RSI</b>	
KX 100	88-96	<b>RSI</b>	
KX 125	82-82	<b>SI</b>	
KX 250	82-82	<b>SI</b>	
KXT 250 Tecate	84-84		<b>HF</b>

<b>POLARIS</b>			
200 Phoenix	05-09	<b>ATS</b>	
200 Sawtooth	06-07	<b>ATS</b>	<b>ATS</b>

<b>SUZUKI</b>			
RM 80	90-95		<b>SI</b>
RM 80	96-01		<b>RSI</b>
RM 85	02-04		<b>RSI</b>

<b>TM</b>			
80 Junior	96-00	<b>RSI</b>	

<b>YAMAHA</b>			
YFM 300 Grizzly	12-13	<b>SI</b>	

<b>ZERO</b>			
DS	ZF6.0	10-12	<b>HF</b>
DS	ZF9.0	10-12	<b>HF</b>
MX		10-12	<b>HF</b>
S	ZF6.0	10-12	<b>HF</b>
X		10-12	<b>HF</b>
XU		11-12	<b>HF</b>

Available compounds

HF • CS • SI • RSI • ATS

SBS 544

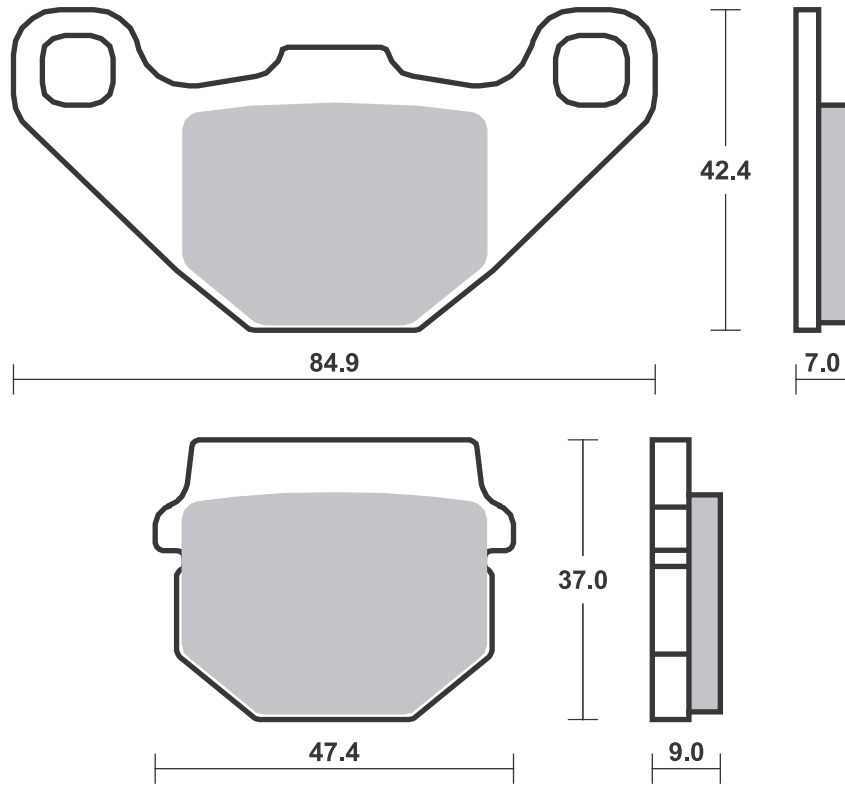





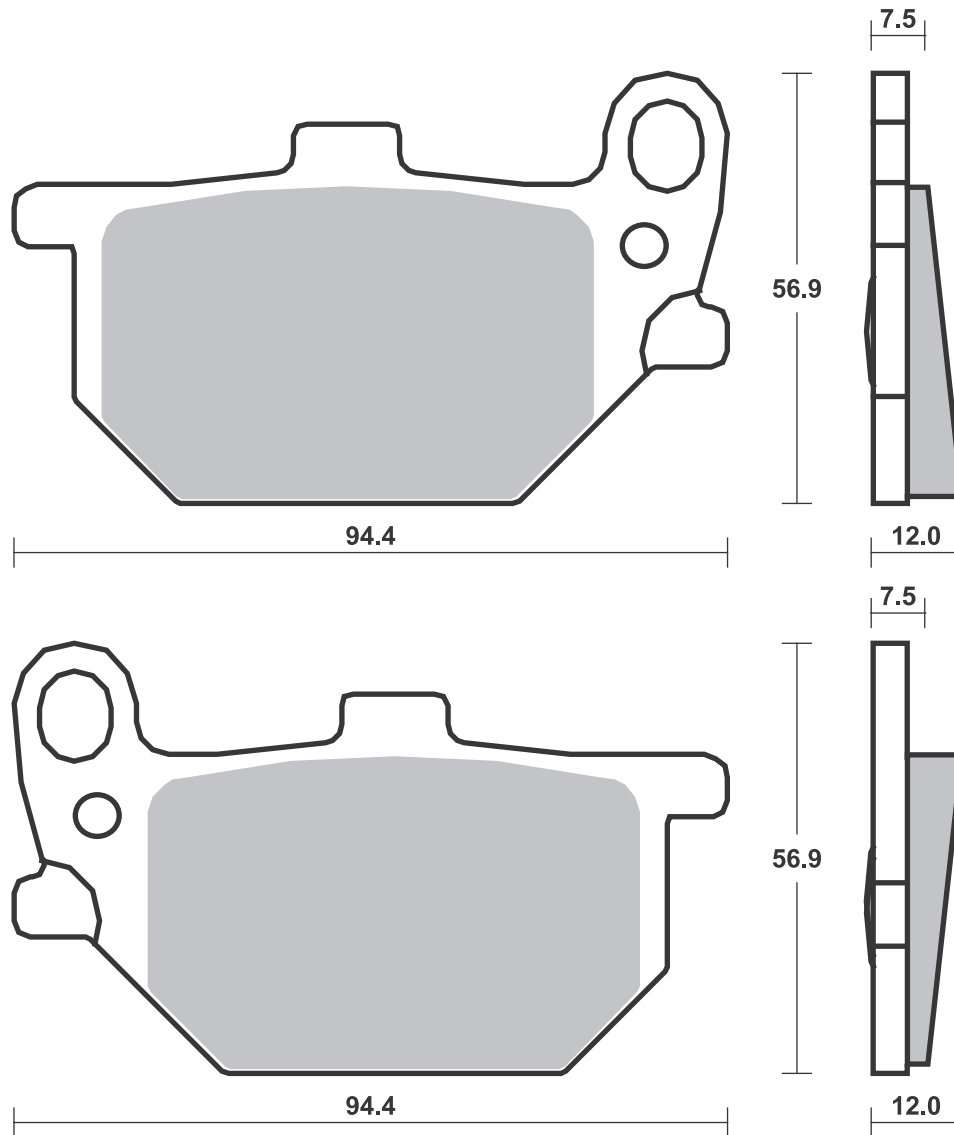

**Applications**

**SBS 546 Recommended compound**



<b>BOMBARDIER</b>		
200 Rally 2x4	05-06	<b>SI</b>
<b>KAWASAKI</b>		
KE 125	86-91	<b>HF</b>
KX 125	83-85	<b>SI</b>
KX 125	86-86	<b>RSI</b>
KDX 200 C	86-88	<b>SI</b>
KDX 200 SR	89-92	<b>SI</b>
KL 250 (KLR 250)	85-97	<b>HF</b>
KLR 250	84-05	<b>HF</b>
KX 250	83-85	<b>SI</b>
KX 250	86-86	<b>RSI</b>
KXT 250 Tecate	85-86	<b>SI</b>
KLF 300 Bayou	88-04	<b>SI</b>
KX 500	83-85	<b>SI</b>
KX 500	86-86	<b>RSI</b>
ZR 550 A1, GP	83-84	<b>HF</b>
KL 600	84-86	<b>HF</b>
KLR 600	84-86	<b>HF</b>
KLR 600 E	85-94	<b>HF</b>
<b>KTM</b>		
GS 125	89-90	<b>SI</b>
MX 125	89-90	<b>SI</b>
GS 250	89-90	<b>SI</b>
MX 250	89-90	<b>SI</b>
MX 300	90-90	<b>SI</b>
LC4 350	92-95	<b>SI</b>
MX 500	89-91	<b>SI</b>



<b>LAVERDA</b>		
700 El Cid	90-90	<b>HF</b>
<b>POLARIS</b>		
200 Phoenix	05-14	<b>SI</b>
<b>SUZUKI</b>		
GN 125	91-04	<b>HF</b>
GT 125	80-82	<b>HF</b>
GS 450	86-86	<b>HF</b>

**SBS 547 Recommended compound**



<b>YAMAHA</b>		
RD 50 MX	81-87	<b>HF</b>
XJ 550 Maxim	81-83	<b>HF</b>
XJ 550 Seca	81-83	<b>HF</b>
XZ 550	82-82	<b>HF</b>
750 Maxim	81-81	<b>HF</b>
XJ 750 Seca	81-83	<b>HF</b>
XV 920 J	82-82	<b>HF</b>
1100 SE, Maxim	81-81	<b>HF</b>
XJ 1100	81-81	<b>HF</b>
XS 1100 LH Midnight	81-81	<b>HF</b>

Brake Pad 1:1 Drawings, Compounds, Fitments

Available compounds

HF • HS • SI • RSI

SBS 546

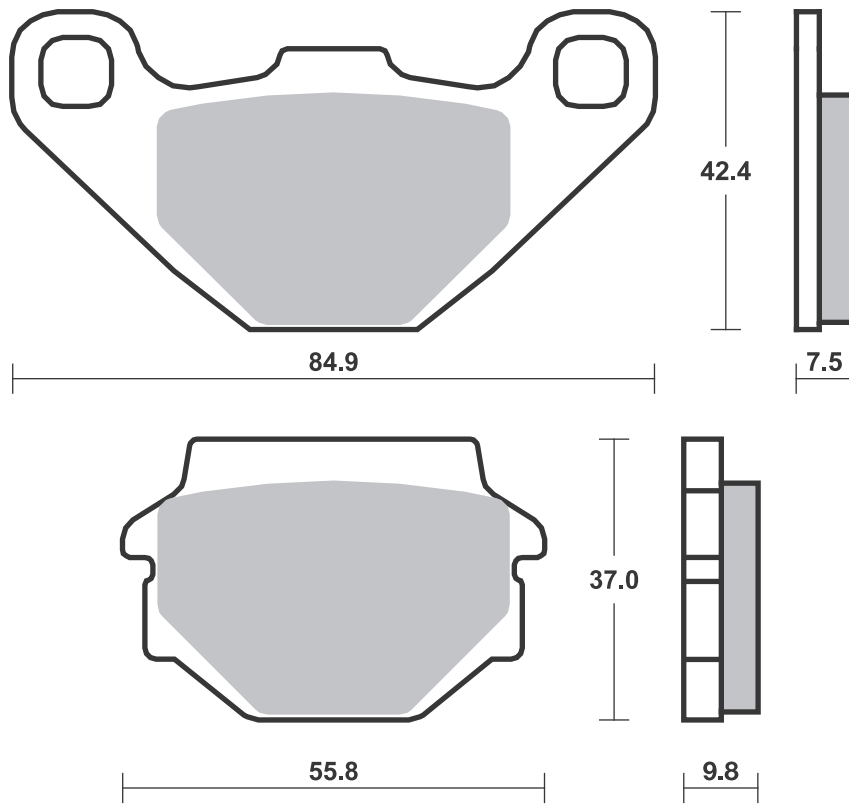

Available compounds

HF • DCC

SBS 547

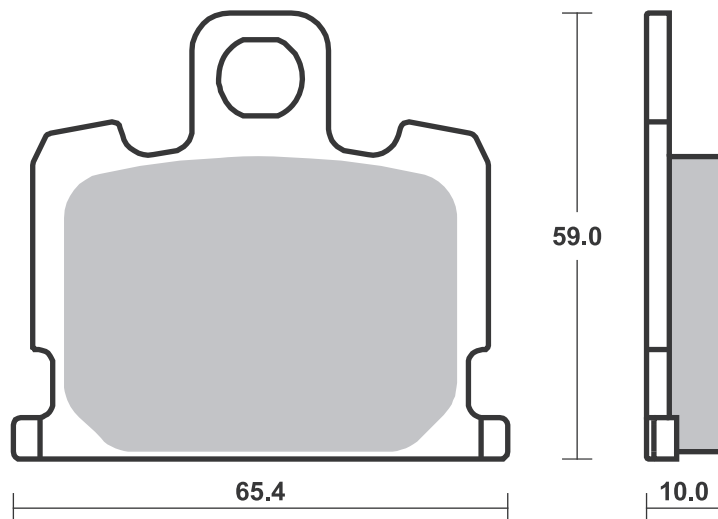



Available compounds

**HF**

**SBS 548**

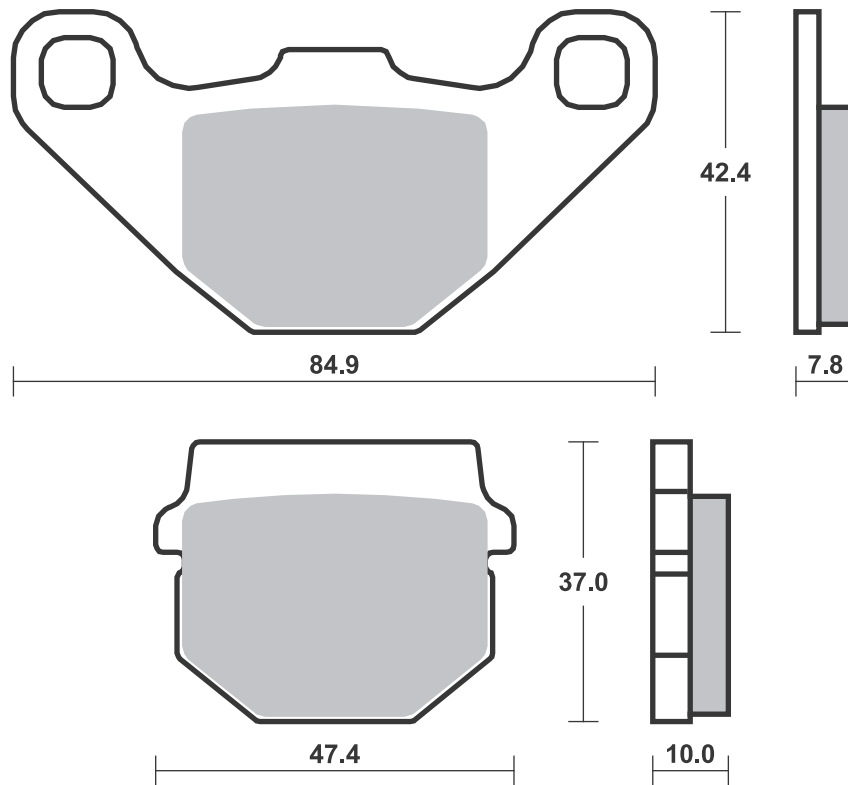

Available compounds

**H.HF • H.CT**

**SBS 549**

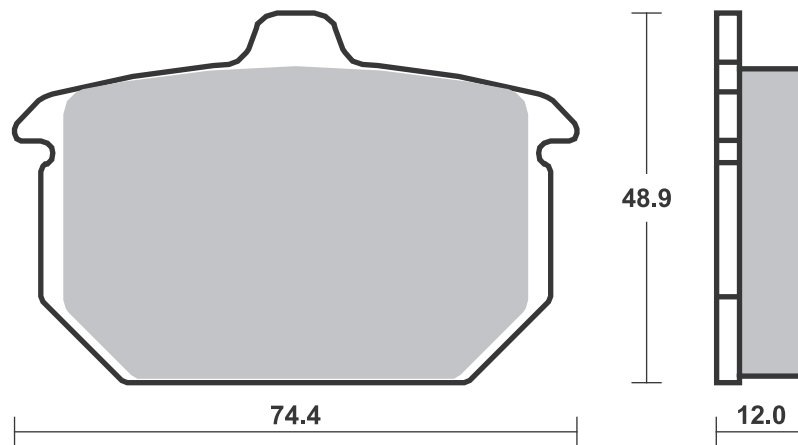

## Applications

### SBS 550 Recommended compound



#### YAMAHA

XV	250 Route 66	88-90	HF
XV	250 Virago	88-88	HF
RZ	350	84-85	HF
XS	400	82-85	HF
XS	400 DOHC	82-82	HF
XV	500 K, Virago	83-83	HF
XV	500 SE	83-83	HF
XZ	550	83-84	HF
XZ	550 RJ, RK	82-83	HF
XZ	550 S	83-84	HF
XT	600	83-86	HF
XJ	650	83-83	HF
XJ	650 Turbo	81-82	HF
XJ	750 Maxim	82-82	HF
XV	920 K, MK, Virago	83-83	HF

### SBS 551 Recommended compound



#### HONDA

CMX	250 Rebel	85-12	HF
-----	-----------	-------	----

#### HYOSUNG

	125 Grand Prix Plus	02-05	HF
GT	125 Comet	02-03	HF
GV	125 Aguila	02-04	HF
RT	125 Karion	02-06	HF
RX	125	00-07	HF
XRX	125 Offroad	99-06	HF
GV	250	02-09	HF
XRX	400	05-08	HF
	600 Comet	03-03	HF
GV	650 Aguila	04-05	HF

#### SYM

	125 Wolf Classic	05-05	HF
MF	180	03-03	HF

### SBS 552 Recommended compound



#### HONDA

VTR	250	88-89	HF
VT	500 ED	82-82	HF
CBX	550 F, F2	82-86	HF

Available compounds

HF • DCC

SBS 550

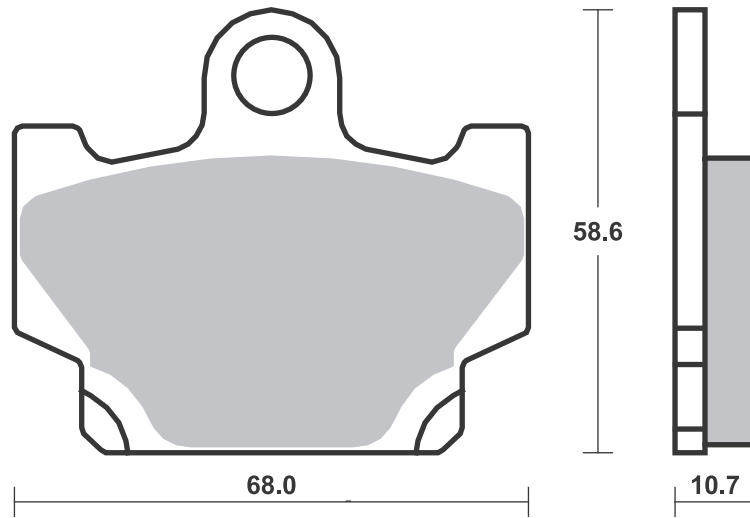

Available compounds

HF

SBS 551

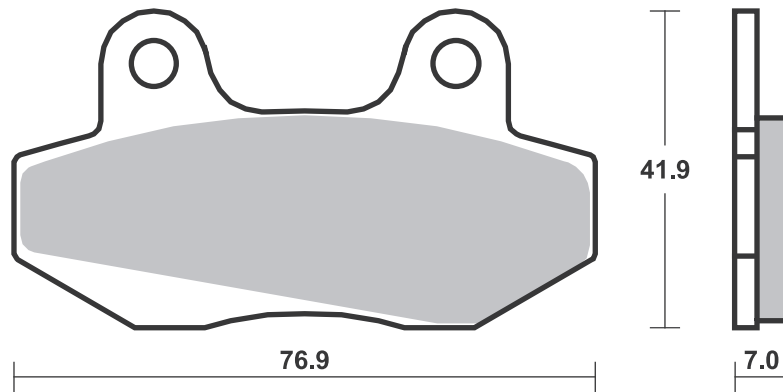

Available compounds

HF

SBS 552

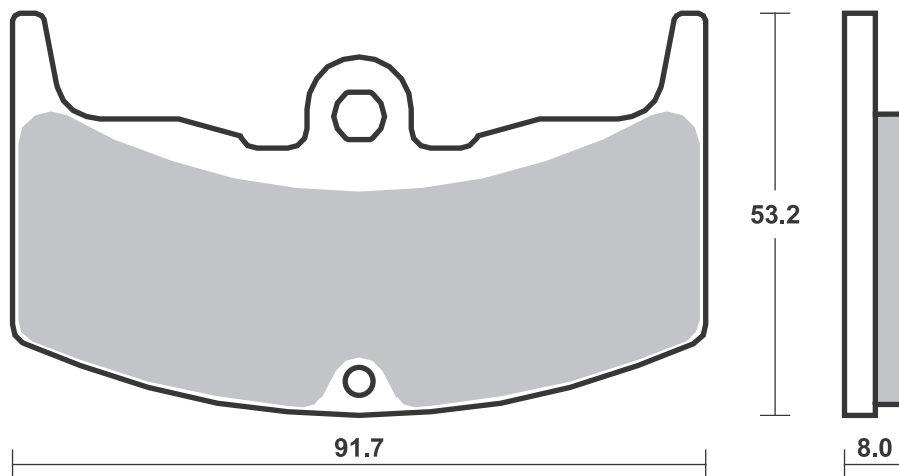





Available compounds

**H.HF • H.CT**

**SBS 553**

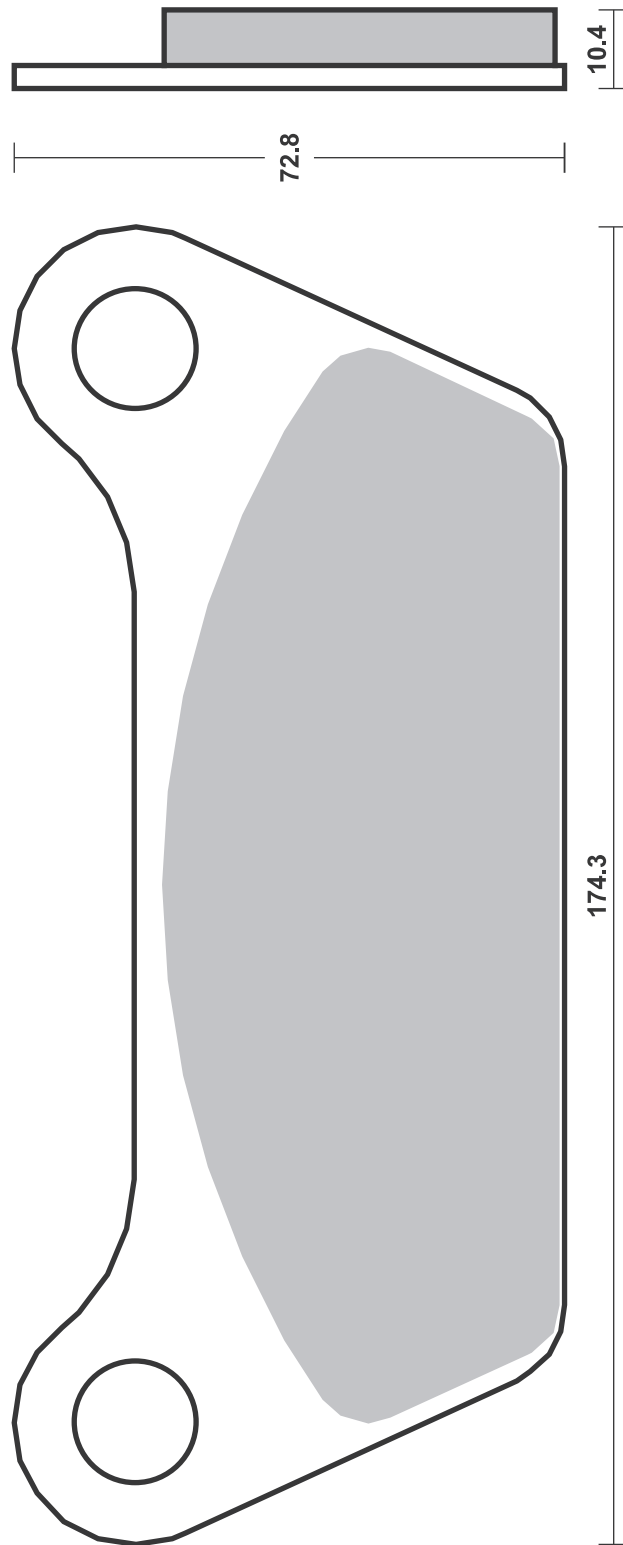



Available compounds

HF • HS

SBS 554

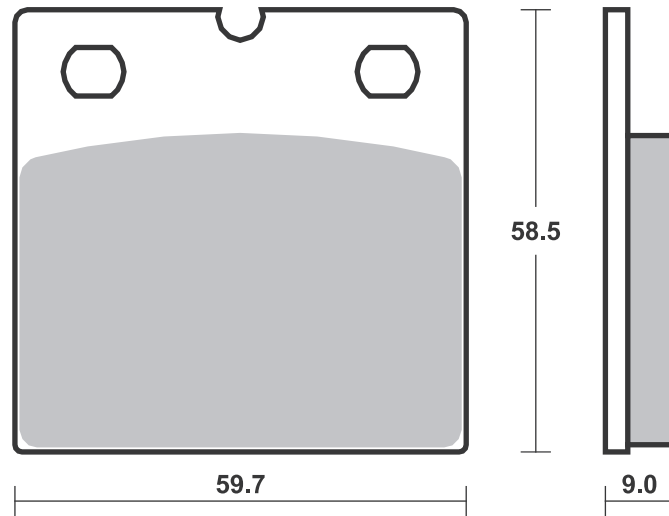

Available compounds

HF • HS • LS • DCC • RQ

SBS 555

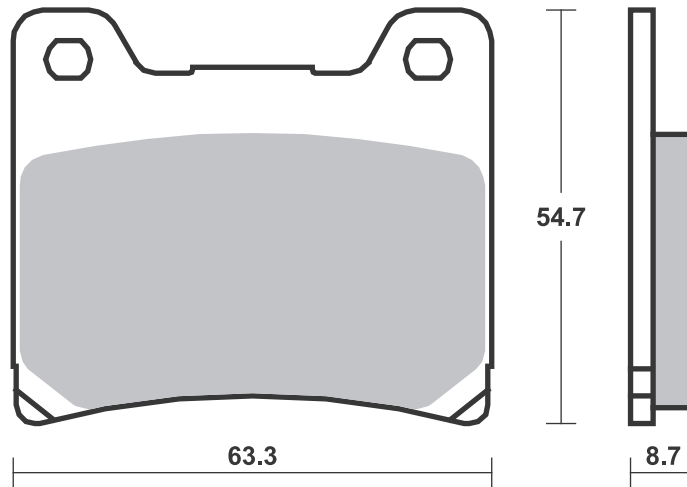

## Applications

### SBS 556 Recommended compound



<b>HYOSUNG</b>			
GT	250 Comet	02-02	<b>LS</b>
	600 Comet	02-02	<b>LS</b>
<b>KAWASAKI</b>			
	600 R, Ninja	89-96	<b>HF</b>
ZX-7R	750 Ninja	89-03	<b>LS</b>
ZRX	1100	96-00	<b>LS</b>
ZX	1100	93-97	<b>LS</b>
ZZR	1100	94-01	<b>LS</b>
ZRX	1200	01-04	<b>LS</b>
ZRX	1200 R	01-08	<b>LS</b>
ZRX	1200 S	01-07	<b>LS</b>
ZX-12R	1200 Ninja	00-06	<b>LS</b>
ZZR	1200	02-04	<b>LS</b>
<b>SUZUKI</b>			
GSF	400 Bandit	91-97	<b>LS</b>
GS	500 F	04-08	<b>HF</b>
GS	550	83-86	<b>HF HF</b>
GSF	600 Bandit	95-99	<b>LS</b>
GSF	600 Bandit / S Bandit	00-04	<b>LS</b>
GSX	600 FW	98-04	<b>LS</b>
GSX	600 Katana	88-89	<b>HF</b>
GSX	600 Katana	90-97	<b>LS</b>
GSX-R	600	92-93	<b>LS</b>
GSX-R	600	97-03	<b>LS</b>



RF	600 R	93-96	<b>LS</b>
SV	650 ,S	99-02	<b>LS</b>
GS	750 Katana	85-86	<b>HF</b>
GS	750 RF	85-85	<b>HF</b>
GSX	750	98-08	<b>LS</b>
GSX	750 FW	98-02	<b>LS</b>
GSX	750 Katana	89-96	<b>LS</b>
GSX-R	750	85-87	<b>HF</b>
GSX-R	750	88-03	<b>LS</b>
TL	1000 RW	98-02	<b>LS</b>
TL	1000 S V-Twin	97-01	<b>LS</b>
GSX	1100 F	93-96	<b>LS</b>
GSX	1100 G	96-98	<b>LS</b>
GSX	1100 Katana	93-93	<b>LS</b>
GSX-R	1100	86-88	<b>HF</b>
GSX-R	1100	89-97	<b>LS</b>
GSF	1200 Bandit	95-00	<b>LS</b>
GSF	1200 S Bandit	01-05	<b>LS</b>
GSX-R	1300 Hayabusa	99-07	<b>LS</b>

### SBS 557 Recommended compound



<b>HYOSUNG</b>			
	125 GA-4	99-99	<b>HF</b>
GA	300	98-01	<b>HF</b>
<b>KAWASAKI</b>			
EL	250	91-94	<b>HF</b>
EL	250 Eliminator	88-89	<b>HF</b>
EX	250 R Ninja	86-87	<b>HF HF</b>
EX	305	83-83	<b>HF</b>
EN	450	85-90	<b>HF</b>
EN	500	90-04	<b>HS</b>
EN	500 Vulcan	96-97	<b>HS</b>
GPZ	550	84-87	<b>HF HF</b>
ZX	550	84-89	<b>HF HF</b>
ZL	600	85-91	<b>HF</b>
ZX	600 Ninja	85-87	<b>HF HF</b>
VN	700 Vulcan	85-85	<b>HF</b>
ZN	700	84-89	<b>HF HF</b>
	750 Vulcan	93-94	<b>HF</b>
GPZ	750	83-87	<b>HF HF</b>
GPZ	750 R	85-86	<b>HF HF</b>
GPZ	750 T	83-85	<b>HF HF</b>
KZ	750	83-84	<b>HF</b>
KZ	750 , Turbo	84-86	<b>HF HF</b>
KZ	750 Eliminator	88-88	<b>HF HF</b>
KZ	750 LTD Twin	83-85	<b>HF HF</b>
VN	750 Twin	88-88	<b>HS</b>
VN	750 Vulcan	86-94	<b>HF</b>
Z	750	83-83	<b>HF</b>
ZX	750 E, GP	83-85	<b>HF HF</b>
VN	800 Vulcan, Classic	95-97	<b>HS</b>
ZL	900 Eliminator	85-86	<b>HF HF</b>
ZX	900	83-84	<b>HF HF</b>



<b>KAWASAKI</b>			
KZ	1000 R Ninja	86-88	<b>HF HF</b>
ZG	1000 Concours	86-93	<b>HF HF</b>
ZG	1000 Concours	94-03	<b>LS</b>
ZL	1000	86-87	<b>HF HF</b>
GPZ	1100	83-86	<b>HF HF</b>
KZ	1100 GP	83-86	<b>HF HF</b>
KZ	1100 R, LTD	84-84	<b>HF HF</b>
ZN	1100 LTD	84-84	<b>HF HF</b>
ZX	1100 GP	83-83	<b>HF HF</b>
ZG	1200 Voyager XII	86-93	<b>HS LS</b>
ZN	1300	83-84	<b>HF HF</b>
ZN	1300 Voy.	85-86	<b>HF HF</b>
VN	1500 Vulcan	87-92	<b>HS LS</b>
VN	1500 Vulcan Classic	97-99	<b>LS</b>
VN	1500 Vulcan Nomad	98-01	<b>LS</b>
VN	1500 Vulcan, SE	87-92	<b>HS LS</b>

Available compounds

HF • HS • LS • RQ

SBS 556

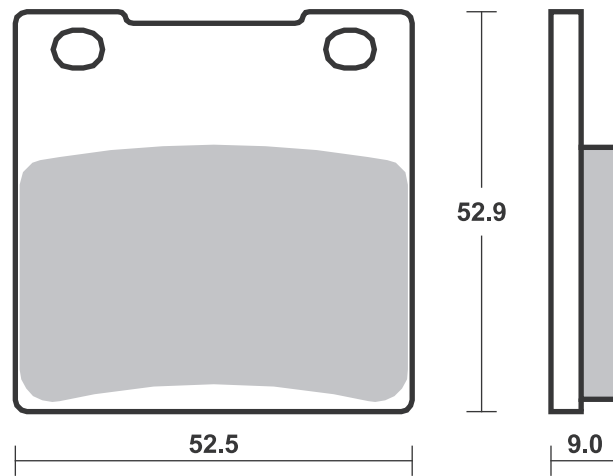

Available compounds

HF • HS • LS

SBS 557

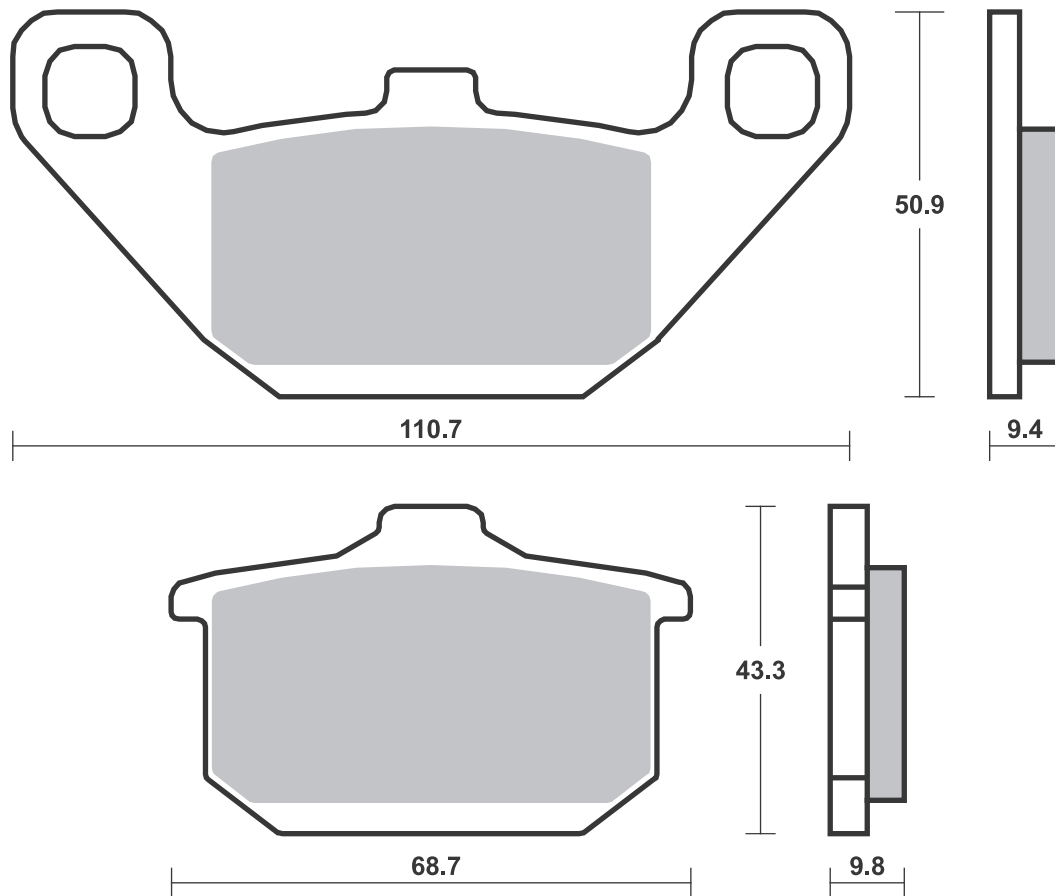

## Applications

### SBS 558 Recommended compound



<b>BENELLI</b>			
TNT	125	17-17	<b>HF</b>
<b>HONDA</b>			
CR	125 RE, RF	84-85	<b>SI</b>
CR	125 RG	86-86	<b>SI</b>
ATC	250 R	85-86	<b>SI SI</b>
ATC	250 X	85-85	<b>SI</b>
CR	250 RE, RF	84-85	<b>SI</b>
CR	250 RG	86-86	<b>SI</b>
MTX	250 R	86-86	<b>SI</b>
TRX	250 R	86-89	<b>SI</b>
TRX	250 R Fourtrax	88-88	<b>SI</b>
TRX	250 X Fourtrax	87-87	<b>SI</b>
XL	250 R	84-87	<b>HF</b>
XR	250 R	84-87	<b>SI</b>
ATC	350 Odyssey	85-85	<b>SI</b>
ATC	350 X	85-85	<b>SI</b>



<b>HONDA</b>			
XL	350 R	84-87	<b>HF</b>
XR	350 R	84-85	<b>SI</b>
CR	500 RE, RF	84-85	<b>SI</b>
CR	500 RG	86-86	<b>SI</b>
XL	500 R	83-87	<b>HF</b>
XR	500 R, Pro Link	83-84	<b>HF</b>
XL	600 R	83-86	<b>HF</b>
XR	600 R	83-87	<b>SI</b>

### SBS 559 Recommended compound



<b>BETA</b>			
50 Rev	00-09	<b>HF</b>	<b>HF</b>
ST 50	97-97	<b>HF</b>	<b>HF</b>
80 EVO Junior	10-11	<b>HF</b>	<b>HF</b>
80 Rev	00-07	<b>HF</b>	<b>HF</b>
ALP 125	99-09	<b>RSI</b>	<b>RSI</b>
ALP 125 4-stroke	00-05	<b>RSI</b>	<b>RSI</b>
SR 125 34	89-89	<b>HF</b>	
TR 125 34,35	89-90	<b>RSI</b>	<b>RSI</b>
TRIAL 125	97-97	<b>RSI</b>	
ALP 200 4-stroke	00-05	<b>RSI</b>	<b>RSI</b>
240 Super Trial	92-92	<b>RSI</b>	
ALP 240	92-92	<b>RSI</b>	
ALP 240	96-96	<b>RSI</b>	
250 Techno	96-96	<b>RSI</b>	<b>RSI</b>
250 Zero	91-91	<b>RSI</b>	
ALP 250	92-92	<b>RSI</b>	
ALP 250	97-03	<b>RSI</b>	<b>RSI</b>
260 Zero	91-91	<b>RSI</b>	
ALP 260	96-96	<b>RSI</b>	
TR 260 34,35,ZERO	89-92	<b>RSI</b>	
<b>CPI</b>			
125 Supermoto	07-12	<b>HF</b>	
<b>DERBI</b>			
DS 50	88-88	<b>HF</b>	
FD 50 Yumbo	84-84	<b>HF</b>	
FD 50 Yumbo Extra	87-87	<b>HF</b>	
FDS 50	87-87	<b>HF</b>	
FDT 50	87-87	<b>HF</b>	
FDT 50 Coppa	85-85	<b>HF</b>	
FDX 50	89-89	<b>HF</b>	
GP1 50	05-05		<b>HF</b>
GPR 50 Nude	04-10		<b>HF</b>
GPR 50 Racing	04-13		<b>HF</b>
75 GPR	89-89		<b>HF</b>
75 Sport, Coppa	84-84	<b>HF</b>	
GPR 75 Sport	92-92		<b>HF</b>
GPR 80 Cup	04-05		<b>HF</b>
125 Senda R 4T	04-12		<b>HF</b>
125 Senda X-Treme			
SM 4T	04-05		<b>HF</b>



<b>DERBI</b>			
125 Terra	07-07	<b>HF</b>	
GP1 125	05-06		<b>HF</b>
GPR 125	05-06		<b>HF</b>
GPR 125 Nude	05-08		<b>HF</b>
GPR 125 Racing	09-09		<b>HF</b>
<b>FANTIC</b>			
250 K-Roo	93-95	<b>RSI</b>	<b>RSI</b>
305	89-90	<b>RSI</b>	<b>RSI</b>
307 Trial	91-94	<b>RSI</b>	<b>RSI</b>
<b>GAS GAS</b>			
TXT 50 Boy	04-04	<b>RSI</b>	<b>RSI</b>
125 Delta	91-91	<b>HF</b>	
125 Pampera	96-03	<b>RSI</b>	<b>RSI</b>
125 Trial	91-91	<b>RSI</b>	
200 Pampera	99-08	<b>RSI</b>	<b>RSI</b>
TX 200	97-98	<b>RSI</b>	<b>RSI</b>
250 Pampera	96-99	<b>RSI</b>	<b>RSI</b>
250 Trial	89-96	<b>RSI</b>	<b>RSI</b>
GT 250 Contact	92-93	<b>RSI</b>	<b>RSI</b>
TX 270	97-98	<b>RSI</b>	<b>RSI</b>
TX 320	97-99	<b>RSI</b>	<b>RSI</b>
325 Halley PXC	86-86	<b>RSI</b>	<b>RSI</b>
327 Trial	89-90	<b>RSI</b>	<b>RSI</b>
GT 327 Contact	89-90	<b>RSI</b>	<b>RSI</b>
370 Pampera	96-00	<b>RSI</b>	<b>RSI</b>
<b>GMA</b>			
4 Piston front Model F			
<b>HUSQVARNA</b>			
50 Husky Boy J,			
R, S	01-10	<b>RSI</b>	
<b>JAYBRAKE</b>			
2 Piston Dual Series Caliper			
4 Piston Quad Series Caliper			
<b>KTM</b>			
SX 60	99-99	<b>RSI</b>	
SX 65	00-01	<b>RSI</b>	



<b>MALAGUTI</b>			
50 Fifty Evolution	91-91	<b>HF</b>	
<b>PERFORMANCE MACHINE</b>			
125 X 2			
125 X 4S			
125 X 4SL			
<b>SCORPA</b>			
TY-S 115 F Trial	06-06	<b>HF</b>	
TY-S 125 F Trial	06-08	<b>HF</b>	
<b>SHERCO</b>			
80 0,8	01-03	<b>HF</b>	<b>HF</b>
ST 125 1,25	01-05	<b>HF</b>	<b>HF</b>
ST 200 2	01-01	<b>HF</b>	<b>HF</b>
ST 250	99-00	<b>RSI</b>	<b>RSI</b>
<b>SJP</b>			
2 Piston Caliper (30-375)			
4 Piston Caliper (30-370)			
<b>TOMOS</b>			
MC 125 T	06-08		<b>HF</b>
SE 125	05-08		<b>HF</b>
SM 125 F	06-08		<b>HF</b>
<b>YAMAHA</b>			
TY 250 R	91-92	<b>HF</b>	
TY 250 Z	93-96	<b>HF</b>	<b>HF</b>

Available compounds

HF • SI • RSI

SBS 558

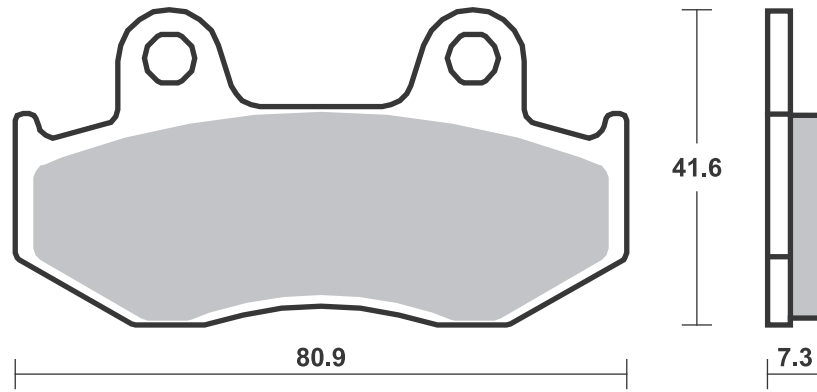

Available compounds

HF • HS • CS • SI • RSI • H.HF • H.CT • H.HS

SBS 559

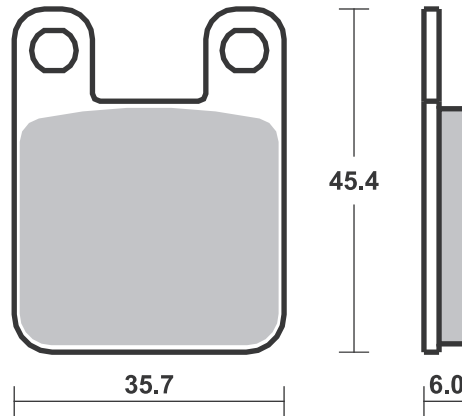

# Applications

## SBS 560 Recommended compound



<b>CAGIVA</b>			
650 Alazzurra	85-88	HF	HF
<b>FANTIC</b>			
HP1 125 Sport	86-86	HF	
<b>GILERA</b>			
80 TG 1, 2, 3	77-82	HF	
125 TG 1, 2, 3 (alu wheels)	77-85	HF	
125 TG1, GR1, RTX	77-85	HF	
<b>GMA</b>			
2 Piston Caliper, small Model B			



<b>JAYBRAKE</b>			
2 Piston Caliper ADC/ADCS			
<b>MOTO-MORINI</b>			
125 Strada	80-80	HF	
250 Strada	80-80	HF	
350 K2	84-87	HF	
350 Strada	76-81	HF	
500 Strada	80-82	HF	

## SBS 561 Recommended compound



<b>HONDA</b>			
CB 450 SC Nighthawk	82-82	HF	
CB 650 SCC Nighthawk	82-82	HF	
VT 700 C Shadow	84-86	HF	
VT 750 C	83-85	HF	

## SBS 562 Recommended compound



<b>HONDA</b>			
ATC 200 X	83-85		SI
ATC 250 R	82-84		SI
ATC 250 X	85-85		SI
TRX 300 EX	93-00		SI
ATC 350 Odyssey	85-85		SI
ATC 350 X	85-89		SI

Brake Pad 1:1 Drawings, Compounds, Fitments



Available compounds

**HF • H.HF • H.CT**

**SBS 560**

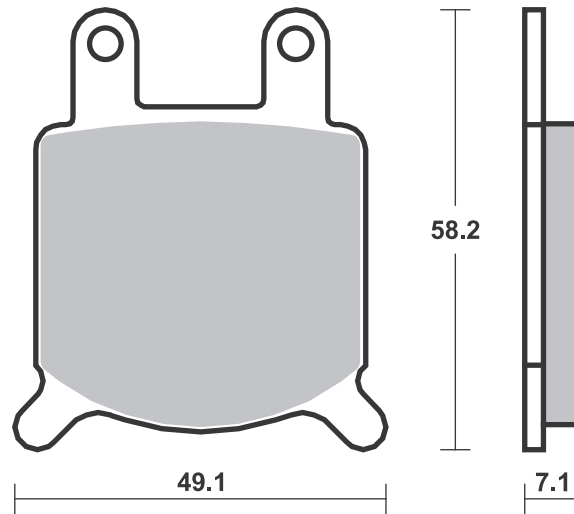

Available compounds

**HF**

**SBS 561**

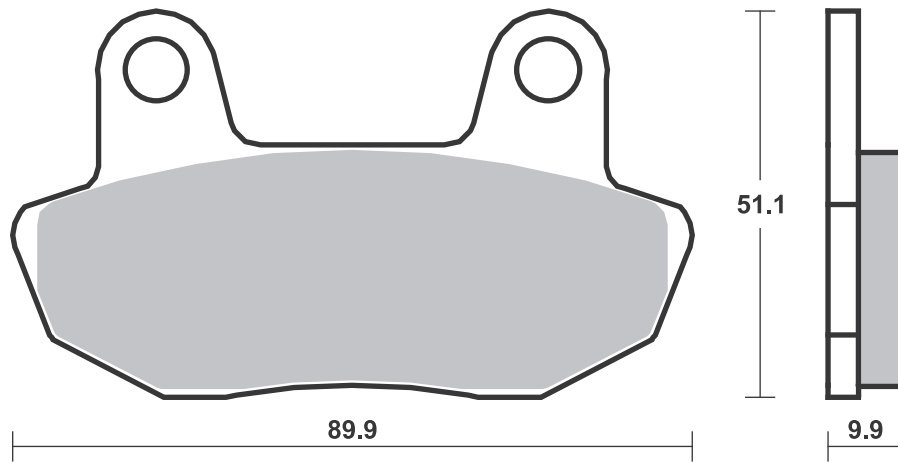

Available compounds

**HF • SI • RSI**

**SBS 562**

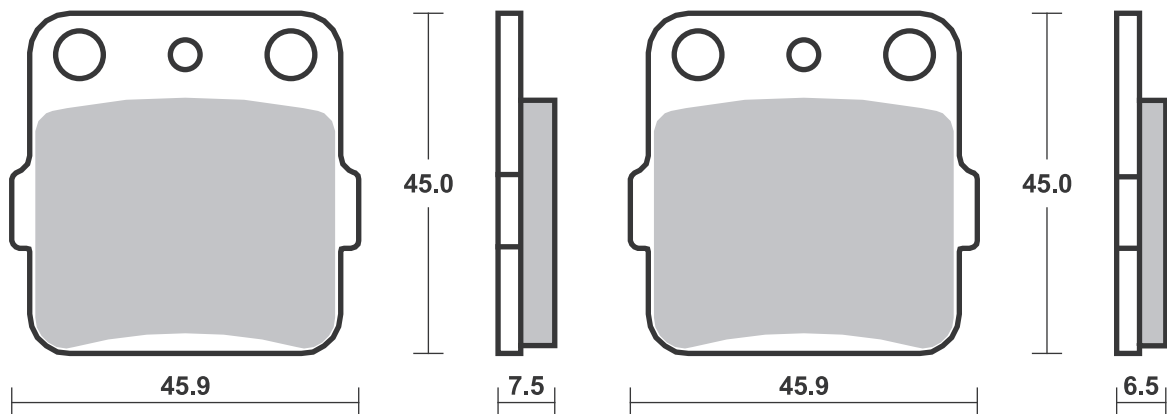

Brake Pad 1:1 Drawings,  
 Compounds, Fitsments



<b>APRILIA</b>			
RS-4	125 (J.Juan cal.)	11-19	<b>HS</b>
<b>BETA</b>			
	350 4.0 Motard	04-06	<b>RSI</b>
<b>BIMOTA</b>			
YB7	400	89-89	<b>HF</b>
	500 Vdue	97-00	<b>HF</b>
	600 Bellaria	91-91	<b>HF</b>
YB9	600 SRI	97-97	<b>HF</b>
BB1	650 Supermono	97-00	<b>HF</b>
SB7	750	96-88	<b>HF</b>
YB4	750	89-89	<b>HF</b>
1D	851 Tesi	91-91	<b>HF</b>
1D	900 Tesi	93-93	<b>HF</b>
DB2	900	92-00	<b>HF</b>
DB3	900 Mantra	97-00	<b>HF</b>
1D	906 Tesi	91-91	<b>HF</b>
	1000 Furano	92-93	<b>HF</b>
2D	1000 Tesi	04-06	<b>HS</b>
YB11	1000	97-00	<b>HF</b>
YB6	1000	89-89	<b>HF</b>
YB8	1000	90-90	<b>HF</b>
	1002 Dieci	91-91	<b>HF</b>
SB6	1100	97-00	<b>HF</b>

**BREMBO RACING CALIPERS**

Billet 20.4756.52/62,  
racing  
Goldline single pin  
20.5165.55/65, road

**CAGIVA**

	125 Raptor	03-10	<b>HF</b>
	500 Mito	07-07	<b>HS</b>
SP	525 Mito	08-10	<b>HS</b>

**CANNONDALE**

S	440	03-03	<b>HF</b>
---	-----	-------	-----------

**DUCATI**

	400 SS, Junior	92-97	<b>HF</b>
	400 SS, Nuda	92-96	<b>HF</b>
	502 Single	93-93	<b>HF</b>
	502 Supermono	93-93	<b>HF</b>
	600 SS Supersport	95-00	<b>HF</b>
M	600 Monster	94-99	<b>HF</b>
	748 Biposto	95-98	<b>HF</b>
	748 SP	95-97	<b>HF</b>
	750 Monster	96-99	<b>HF</b>
	750 SS	91-98	<b>HF</b>
	750 SS Supersport	95-99	<b>HF</b>
	750 SS, Carenara	92-98	<b>HF</b>
	750 SS, Nuda	92-92	<b>HF</b>
	750 Super Sport	92-94	<b>HF</b>
	851 Strada	89-89	<b>HF</b>
	851 Strada	91-92	<b>HF</b>
	851 Superbike	90-90	<b>HF</b>
	888 Roche Replica	91-91	<b>HF</b>
	888 SP V	93-93	<b>HF</b>
	888 SP4	92-95	<b>HF</b>
	888 SPO	93-93	<b>HF</b>
	888 SPS	92-95	<b>HF</b>
	888 Strada	93-93	<b>HF</b>
	888 Superbike	93-93	<b>HF</b>
	900 FE	97-98	<b>HF</b>
	900 M, IL Monster	93-99	<b>HF</b>

**DUCATI**

	900 SL	92-97	<b>HF</b>
	900 SS	90-94	<b>HF</b>
	900 SS Supersport	95-97	<b>HF</b>
	900 SSR	92-92	<b>HF</b>
907	900 I. E.	90-93	<b>HF</b>
M	900 Street Monster	94-99	<b>HF</b>
	916 Biposto	94-98	<b>HF</b>

**GAS GAS**

SM	125	02-13	<b>HF</b>
SM	250	02-13	<b>HF</b>
SM	400 fse	02-02	<b>HF</b>
SM	450 fse	03-06	<b>HF</b>
SM	450 FSR	07-13	<b>HF</b>

**GILERA**

	350 Saturno		
	Bialbero	90-90	<b>HF</b>
	500 Saturno		
	Bialbero	90-90	<b>HF</b>
	500 Saturno Piuma	90-94	<b>HF</b>

**HONDA**

RS	125	95-03	#DC
RS	250 R	93-93	#DC

**HUSQVARNA**

SM	400 R	02-02	<b>HF</b>
SM	450 R	03-04	<b>HF</b>
SM	570 R	01-08	<b>HF</b>

**INDIAN**

	1700 Chief		
	Blackhawk	11-13	<b>H.HS</b>
	1700 Chief Bomber	10-13	<b>H.HS</b>
	1700 Chief Classic	10-13	<b>H.HS</b>
	1700 Chief Dark		
	Horse	10-13	<b>H.HS</b>
	1700 Chief Deluxe	09-13	<b>H.HS</b>
	1700 Chief		
	Roadmaster	09-13	<b>H.HS</b>
	1700 Chief Standard	09-13	<b>H.HS</b>
	1700 Chief Vintage	09-13	<b>H.HS</b>

**ITALJET**

	900 Grifon	00-00	<b>HF</b>
--	------------	-------	-----------

**KTM**

	125 Sting	99-99	<b>HF</b>
SX	450 SM Factory		
	Replica	04-07	<b>RSI</b>
	600 Duke	93-94	<b>HF</b>
	620 Duke	96-98	<b>HF</b>
	640 Duke	99-02	<b>HF</b>
LC4	640 Supermoto	03-03	<b>HF</b>
LC4	660 SM Factory		
	Replica	02-02	<b>RSI</b>
SMC	660 Supermoto	03-03	<b>HF</b>

**LAVERDA**

	650	92-92	<b>HF</b>
	668 668	96-97	<b>HF</b>
	668 Ghost,		
	Diamante	97-97	<b>HF</b>
	750 Cup	98-01	<b>HF</b>
	750 Diamante	97-01	<b>HF</b>
	750 Ghost Strike	97-01	<b>HF</b>

**LAVERDA**

	750 S Formula	97-01	<b>HF</b>
	750 S, S Carenata	97-01	<b>HF</b>
	750 Sport	99-01	<b>HF</b>
	750 Strike/		
	Black Strike	99-01	<b>HF</b>
	750 T8	98-01	<b>HF</b>
TTS	800	99-99	<b>HF</b>
JOTA	1000	95-95	<b>HF</b>

**MOTO-GUZZI**

	750 Ippogrifo	97-97	<b>HF</b>
	1000 Daytona	91-02	<b>HF</b>
	1000 Quota	92-92	<b>HF</b>
RS	1000 Daytona	97-00	<b>HF</b>
V10	1000 Centauro	96-00	<b>HF</b>
	1100 California		
	Jackal	00-00	<b>HF</b>
	1100 California		
	Jackal Basic	00-00	<b>HF</b>
	1100 California		
	Special	99-00	<b>HF</b>
	1100 Sport	96-04	<b>HF</b>
EV	1100 California	97-00	<b>HF</b>
V11	1100 Sport	97-00	<b>HF</b>

**MZ**

	660 (MUZ)		
	Skorpion		
	Cup	99-99	<b>HF</b>
	660 (MUZ)		
	Skorpion		
	Replica	97-99	<b>HF</b>
	660 (MUZ)		
	Skorpion		
	Sport	95-99	<b>HF</b>
	660 (MUZ)		
	Skorpion		
	Tour	95-00	<b>HF</b>
	660 (MUZ)		
	Skorpion		
	Traveller	99-00	<b>HF</b>

**NORTON**

F-1	600	90-90	<b>HF</b>
TT	600	92-92	<b>HF</b>

**REVTECH**

Wilwood Caliper front/rear

**SACHS**

	500 MadAss	05-08	<b>HF</b>
--	------------	-------	-----------

**TM**

SMR	125	05-05	<b>RSI</b>
SMF	400 F	02-02	<b>RSI</b>
SMR	400 F	03-03	<b>RSI</b>
SMR	450 F	04-04	<b>RSI</b>
SMX	450 F	03-03	<b>RSI</b>
SMR	530 F	03-03	<b>RSI</b>
SMX	600 F	03-03	<b>RSI</b>

**VOR**

SM	400	02-02	<b>RSI</b>
SM	450	02-04	<b>RSI</b>
	500 492 Super		
	Motard	00-01	<b>HF</b>
SM	530	02-04	<b>RSI</b>



Available compounds

**HF • HS • DC • RST • DCC • RSI • H.HF • H.CT • H.HS SBS 566**

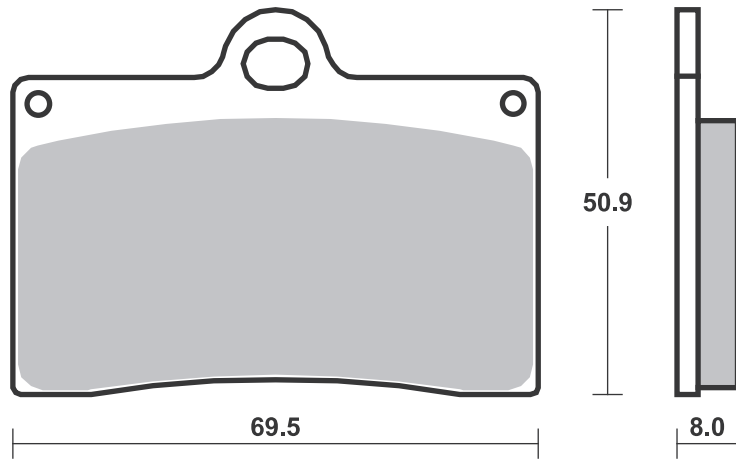



Available compounds

**HF • HS • LS • DCC**

**SBS 570**

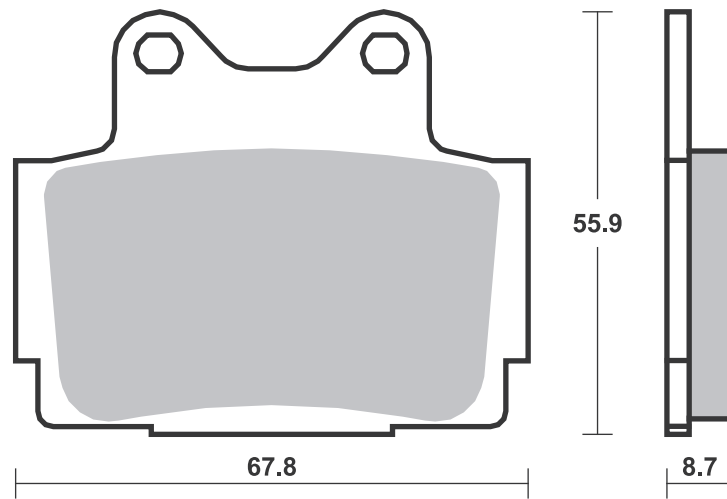

Available compounds

**HF**

**SBS 571**

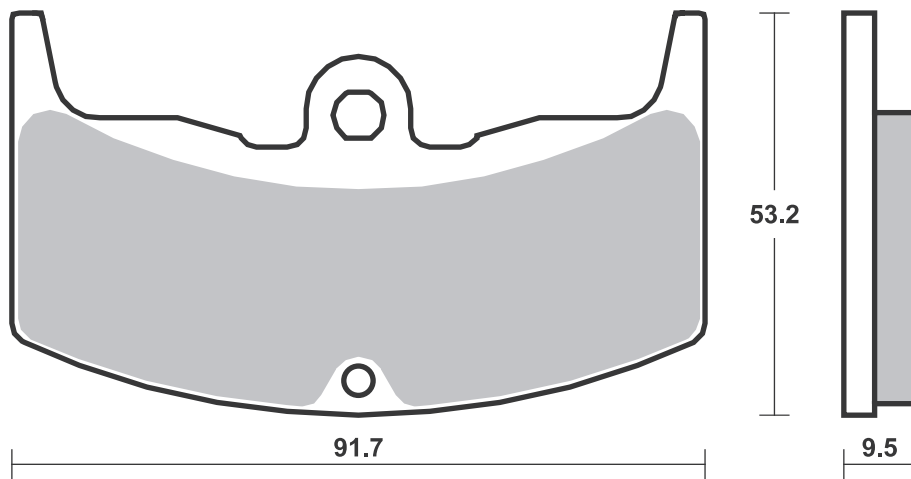



Available compounds

HF • HS • LS • DCC

SBS 572

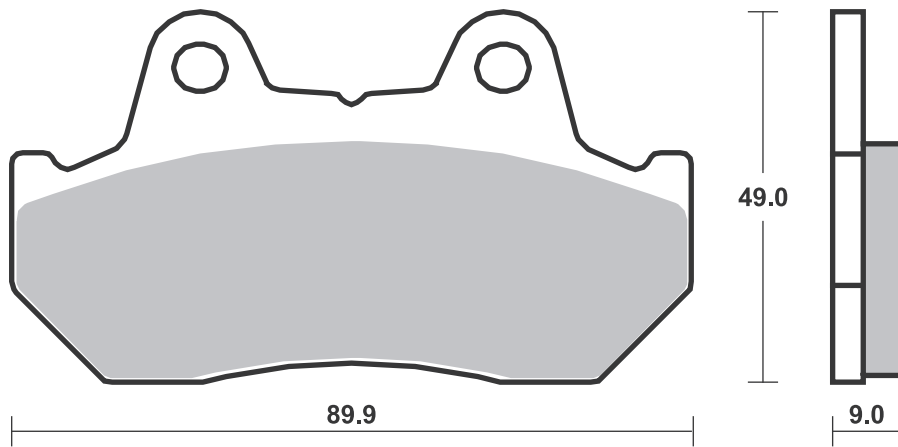

Available compounds

HF • CS • SI • RSI

SBS 574

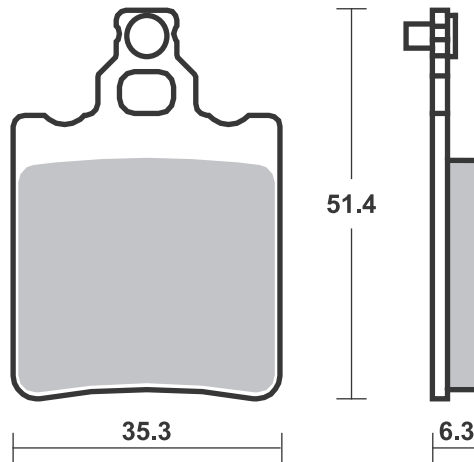

Available compounds

HF • LS • SI • RSI

SBS 575

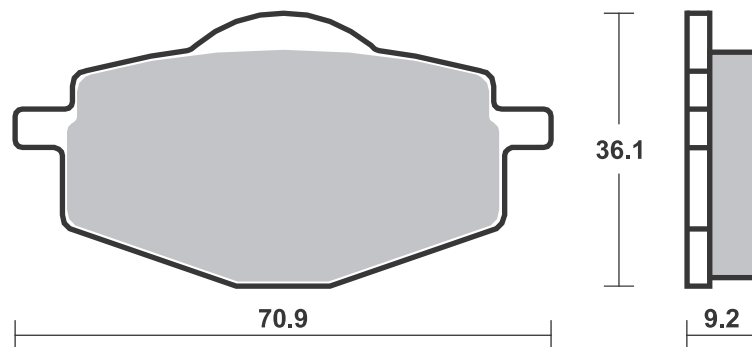





Available compounds

HF • SI • RSI

SBS 576

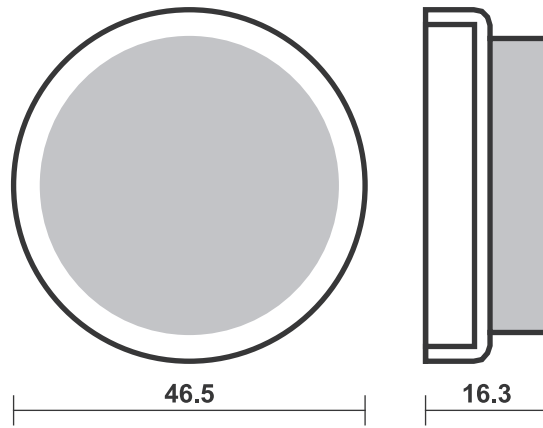

Available compounds

HF • HS • LS • DCC

SBS 577

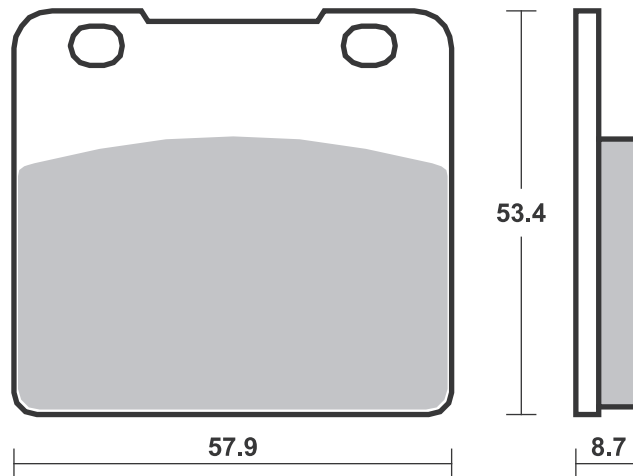



Available compounds

**H.HF • H.CT • H.HS**

**SBS 579**

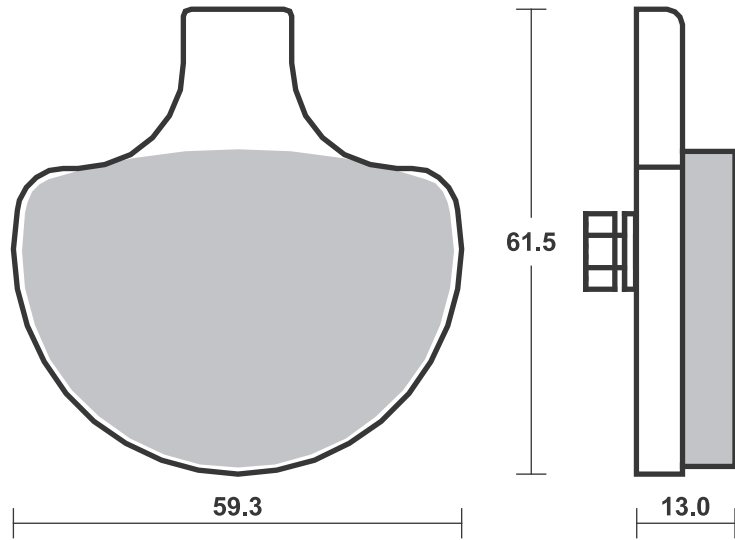
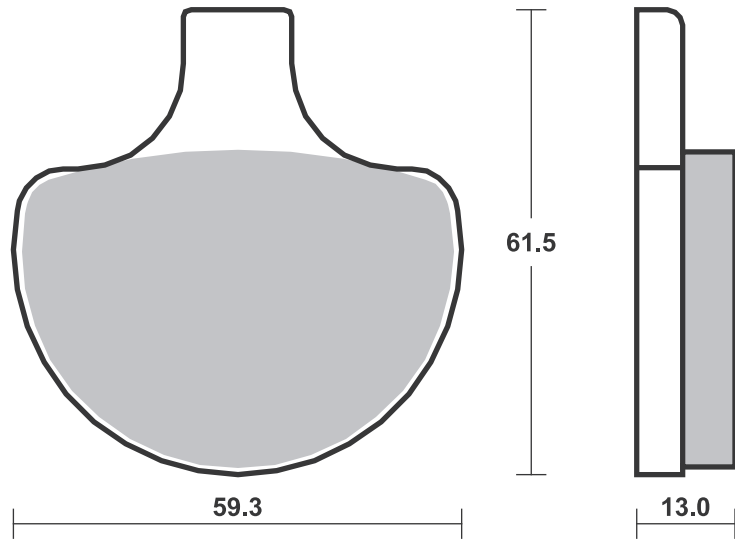

Available compounds

**HF • SI • RSI**

**SBS 580**

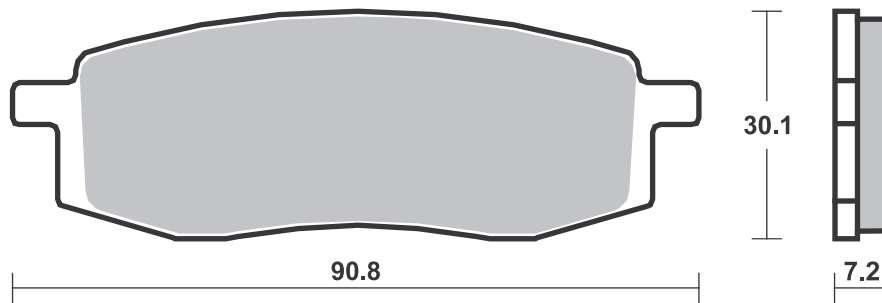

Brake Pad 1:1 Drawings,  
Compounds, Fitments



Available compounds

HF

SBS 581

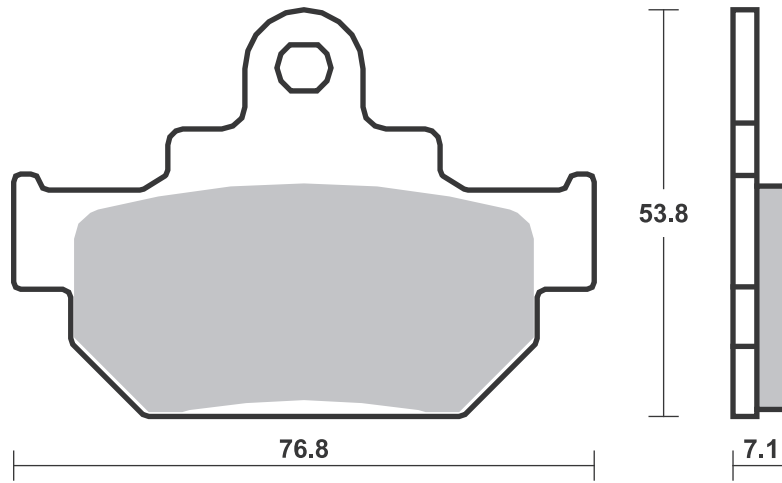

Available compounds

HF

SBS 582

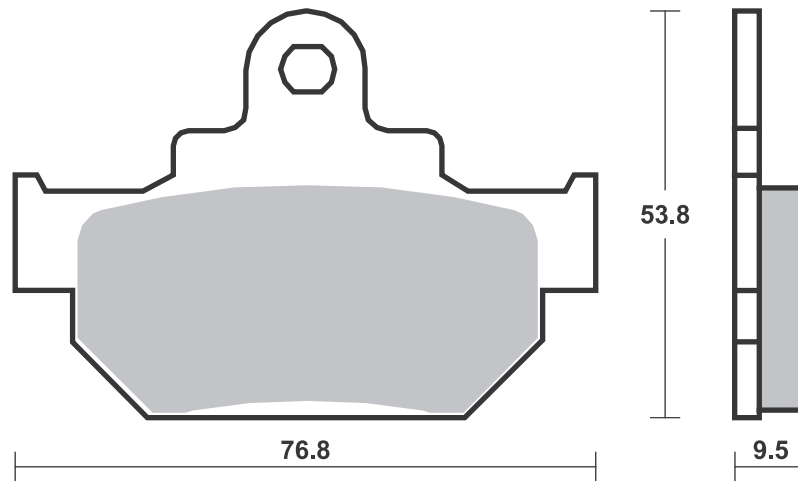

Available compounds

HF • SI • RSI

SBS 584

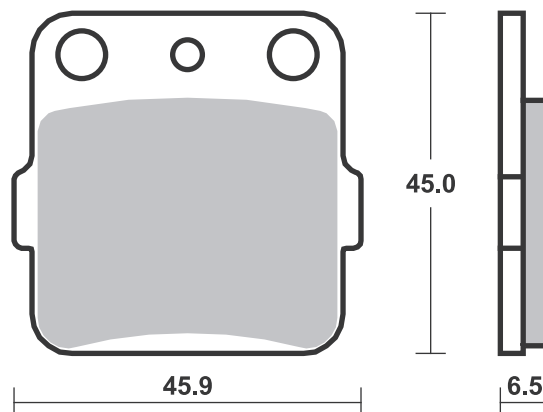



Available compounds

HF

SBS 585

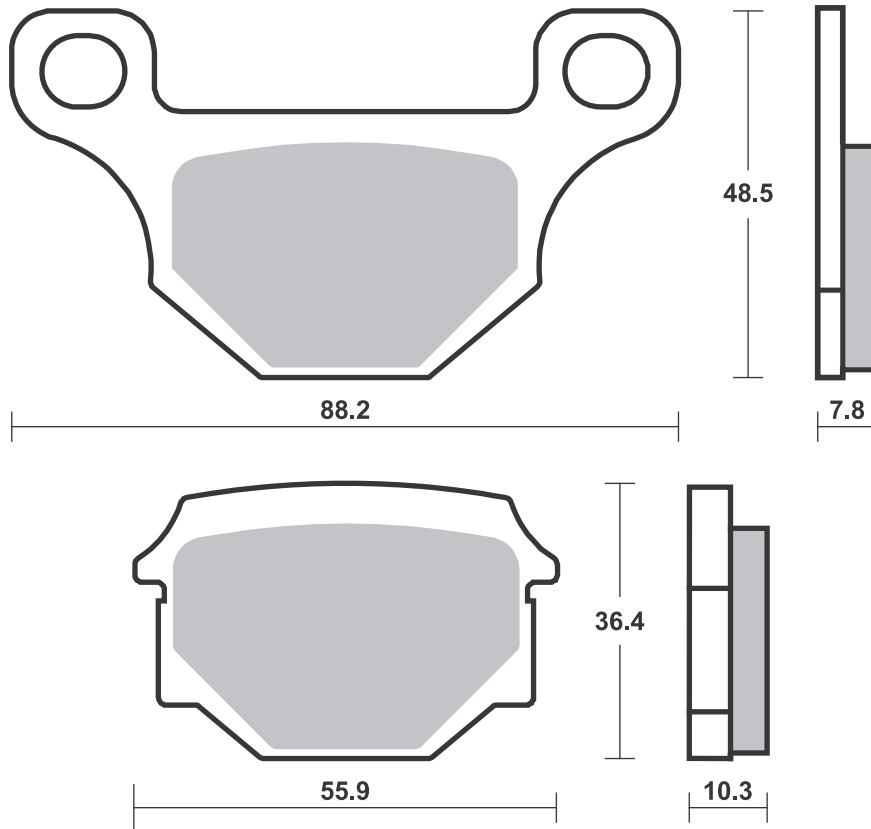

Available compounds

HF • LS • SI • RSI

SBS 586

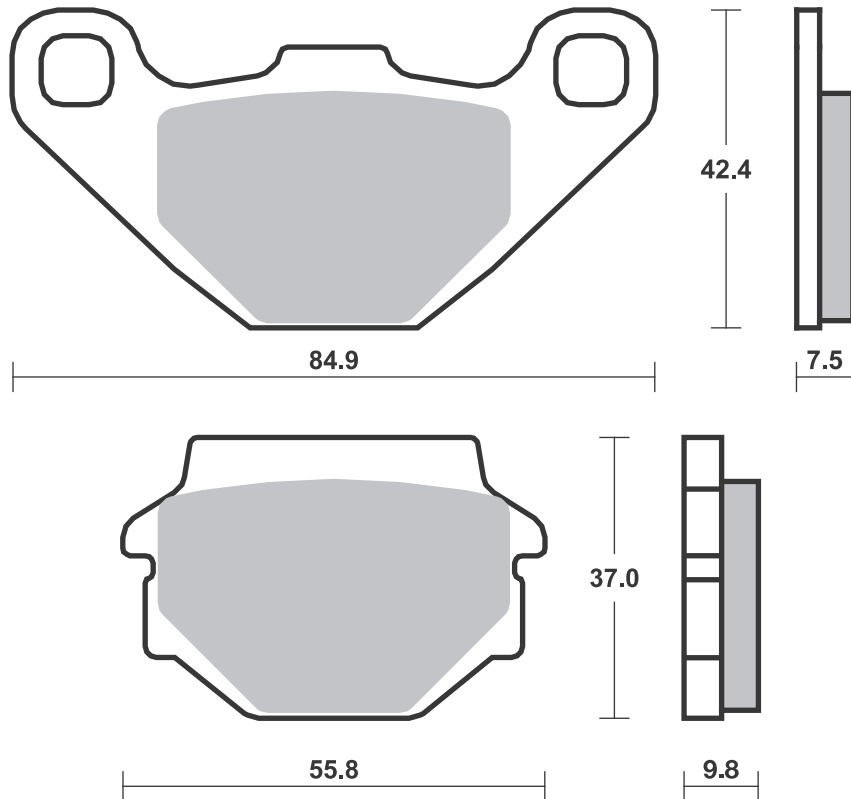





Available compounds

**HF**

**SBS 588**

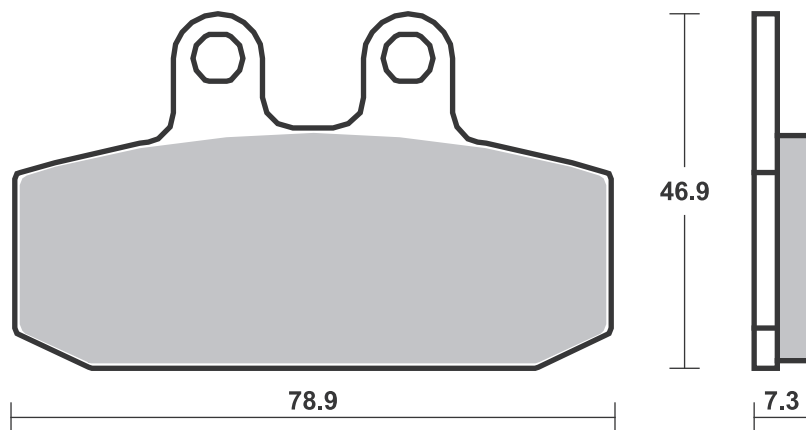

Available compounds

**HF • CS • SI • RSI**

**SBS 589**

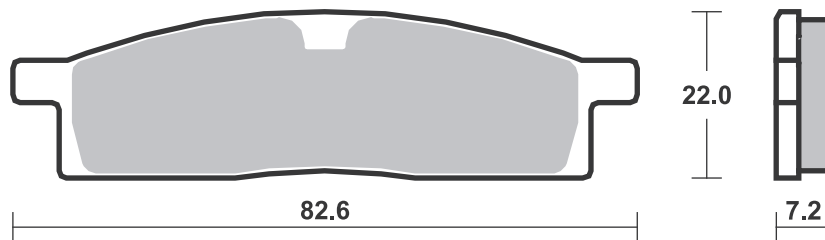

Available compounds

**HF • HS • LS • DCC**

**SBS 590**

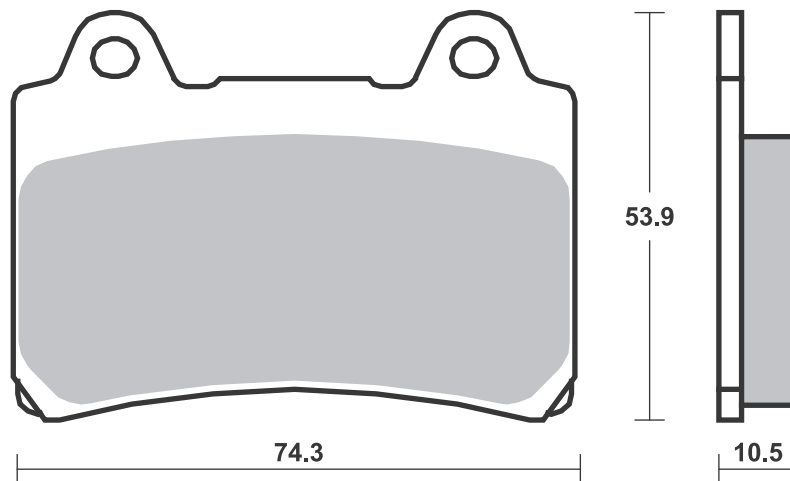

**SBS 591** Recommended compound



<b>KAWASAKI</b>			
KSF	250 Mojave	87-02	<b>SI</b>
KXF	250 Tecate	87-88	<b>SI</b>
KXT	250 Tecate	87-88	<b>SI</b>
KEF	300 Lakota	95-04	<b>SI</b>

<b>SUZUKI</b>			
LT	230	86-93	<b>SI</b>
LT	250	85-94	<b>SI</b>
LT	250	89-90	<b>SI</b>
LT	500	87-95	<b>SI</b>

**SBS 592** Recommended compound



<b>ARCTIC CAT</b>			
	400 DVX	04-08	<b>SI</b>

<b>HONDA</b>			
CR	85 R, R Expert	03-12	<b>RSI</b>
CRF	150 R	07-21	<b>RSI</b>
ATC	200 X	83-85	<b>SI</b>
ATC	200 X	86-87	<b>SI SI</b>
TRX	250 EX Sportrax	01-08	<b>SI</b>
TRX	250 X	08-13	<b>SI</b>
TRX	300 EX	93-00	<b>SI</b>
TRX	300 EX Sportrax	01-08	<b>SI SI</b>
TRX	300 X	09-09	<b>SI SI</b>
TRX	400 EX Sportrax	01-08	<b>SI SI</b>
TRX	400 Fourtrax EX	99-00	<b>SI SI</b>
TRX	400 X	09-12	<b>SI SI</b>
TRX	420 FA / FPA	09-13	<b>SI</b>
TRX	420 FPE / FPM 4x4	09-14	<b>SI</b>
TRX	450 EX Sportrax	01-05	<b>SI SI</b>

<b>KAWASAKI</b>			
KX	80	88-00	<b>RSI</b>
KX	85	01-22	<b>RSI</b>
KX	85 II	01-22	<b>RSI</b>
KX	100	88-21	<b>RSI</b>
KX	112	22-22	<b>RSI</b>
KLX	140 , L	08-21	<b>SI</b>
KSF	250 Mojave	87-02	<b>SI</b>
KXF	250 Tecate	87-88	<b>SI</b>



<b>KAWASAKI</b>			
KXT	250 Tecate	87-88	<b>SI</b>
KEF	300 Lakota	95-04	<b>SI</b>
KFX	400	02-05	<b>SI</b>
KFX	450	07-15	<b>SI</b>

<b>SUZUKI</b>			
RM	100	03-03	<b>RSI</b>
LT	230	86-93	<b>SI</b>
LT	250	89-90	<b>SI</b>
LT-Z	400 Quad Sport	02-19	<b>SI</b>
RM	500	88-89	<b>RSI</b>

<b>TM</b>			
	80 Junior	96-00	<b>RSI</b>

<b>YAMAHA</b>			
YZ	65	19-21	<b>RSI</b>
YZ	80	93-01	<b>RSI</b>
YZ	85 , LW	02-21	<b>RSI</b>
YFS	200 R Blaster	03-06	<b>SI</b>
YFM	250 Raptor	09-14	<b>SI</b>
YFM	350 FXG-FXM		
	Wolverine	95-11	<b>SI</b>
YFM	350 R Raptor	04-14	<b>SI</b>
YFM	350 XG,XH Warrior	95-96	<b>SI</b>
YFM	350 XT, XU Warrior	87-88	<b>SI</b>
YFZ	350 Banshee	87-06	<b>SI</b>
YFZ	450 S	04-05	<b>SI</b>
YFM	600 4x4 Grizzly	98-01	<b>SI</b>



<b>YAMAHA</b>			
YFM	660 FWAP 4x4		
	Grizzly	02-08	<b>SI</b>
YFM	660 RN Raptor	01-09	<b>SI SI</b>

Brake Pad 1:1 Drawings, Compounds, Fitments

Available compounds

HF • SI • RSI

SBS 591

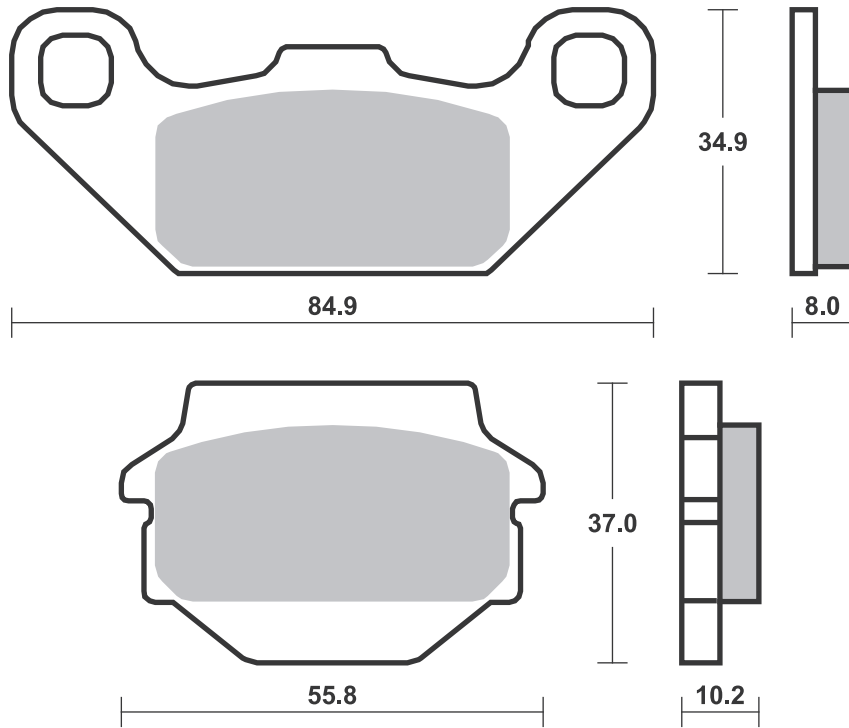

Available compounds

HF • LS • CS • SI • RSI

SBS 592

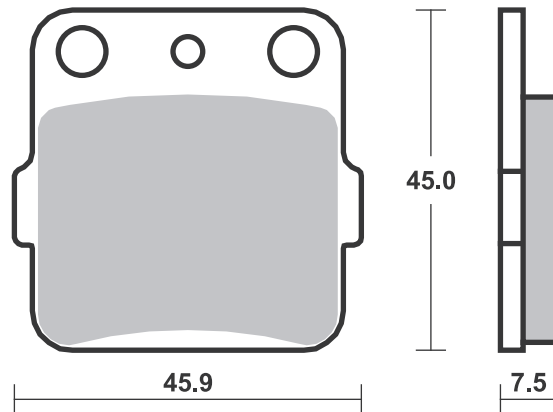



Available compounds

**HF • HS • RST • DCC • RQ**

**SBS 593**

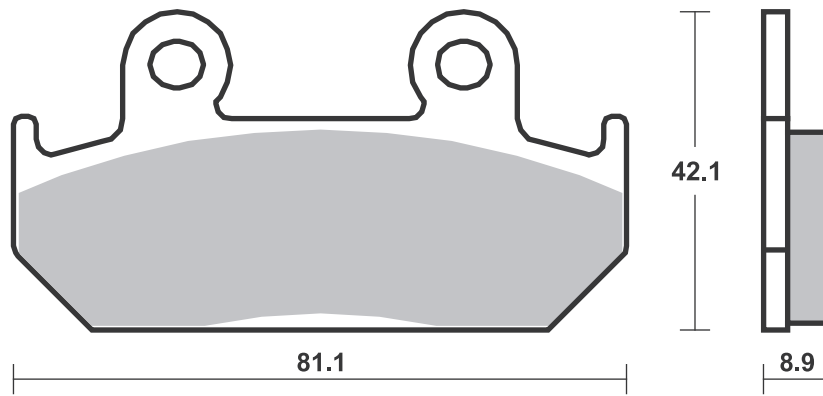

Available compounds

**HF**

**SBS 594**

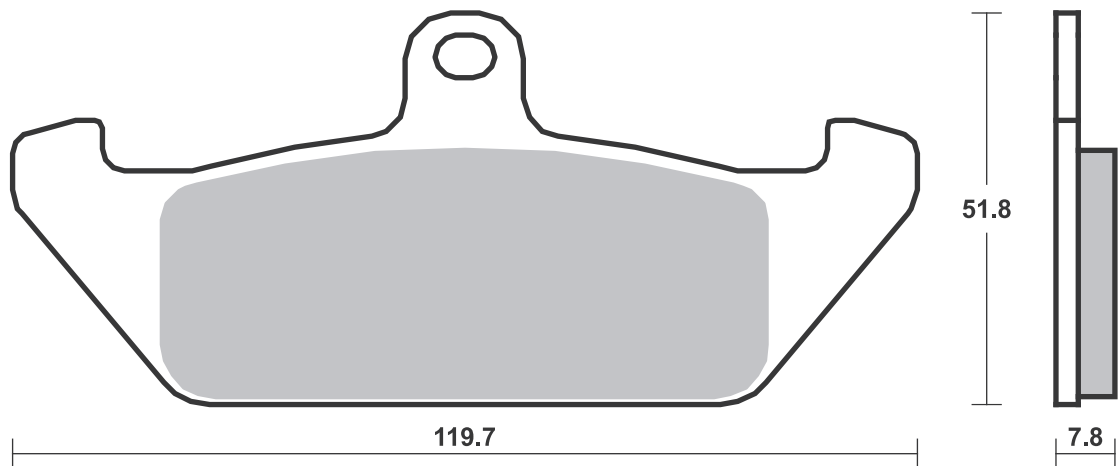

Available compounds

**HF**

**SBS 595**

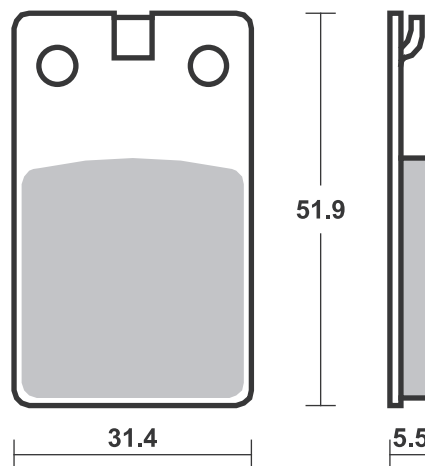

**MALAGUTI**

MDX	50 Gold Enduro	87-87	<b>HF</b>
MLX	50 Enduro	87-87	<b>HF</b>

**MOTO-GUZZI**

NTX	750	90-93	<b>HS</b>
-----	-----	-------	-----------

**YAMAHA**

RT	180	90-93	<b>HF</b>
TT	600	89-89	<b>HF</b>

**HYOSUNG**

GT	250 Comet	02-02	<b>HS</b>
	600 Comet	02-02	<b>HS</b>

**KAWASAKI**

EX	250 R Ninja	88-07	<b>HF</b>
EX	500	87-89	<b>HF</b>
EX	500	90-93	<b>HS</b>
EX	500 Ninja	94-97	<b>HS</b>
ZR	550 Zephyr	90-99	<b>HS</b>
ZL	600 B2 Eliminator	95-98	<b>HS</b>
ZX	600 Ninja	90-93	<b>LS</b>
ZX	600 Ninja R	88-97	<b>HS LS</b>
ZX-6R	600 (ZX6)	90-93	<b>LS</b>
KLR	650 Tengai	89-92	<b>HS</b>
ZR	750 Zephyr	91-95	<b>HS LS</b>
ZG	1000 Concours	94-03	<b>HS</b>
ZX-10	1000	88-90	<b>HS LS</b>
ZR	1100 Zephyr	92-95	<b>LS</b>
ZZR	1100	90-93	<b>LS</b>

**SUZUKI**

GSF	400 Bandit	91-92	<b>HS</b>
GS	450	90-90	<b>HS LS</b>
VX	800 L-P	90-93	<b>HS</b>
GSX	1100 G	94-95	<b>HS</b>

Available compounds

HF • HS

SBS 596

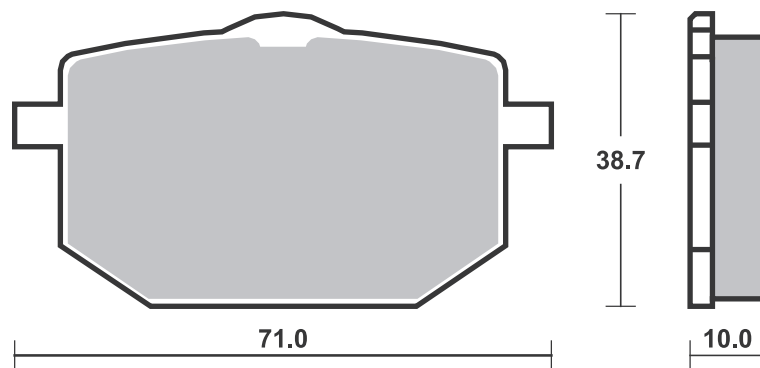

Available compounds

HF • HS • LS • RQ

SBS 597

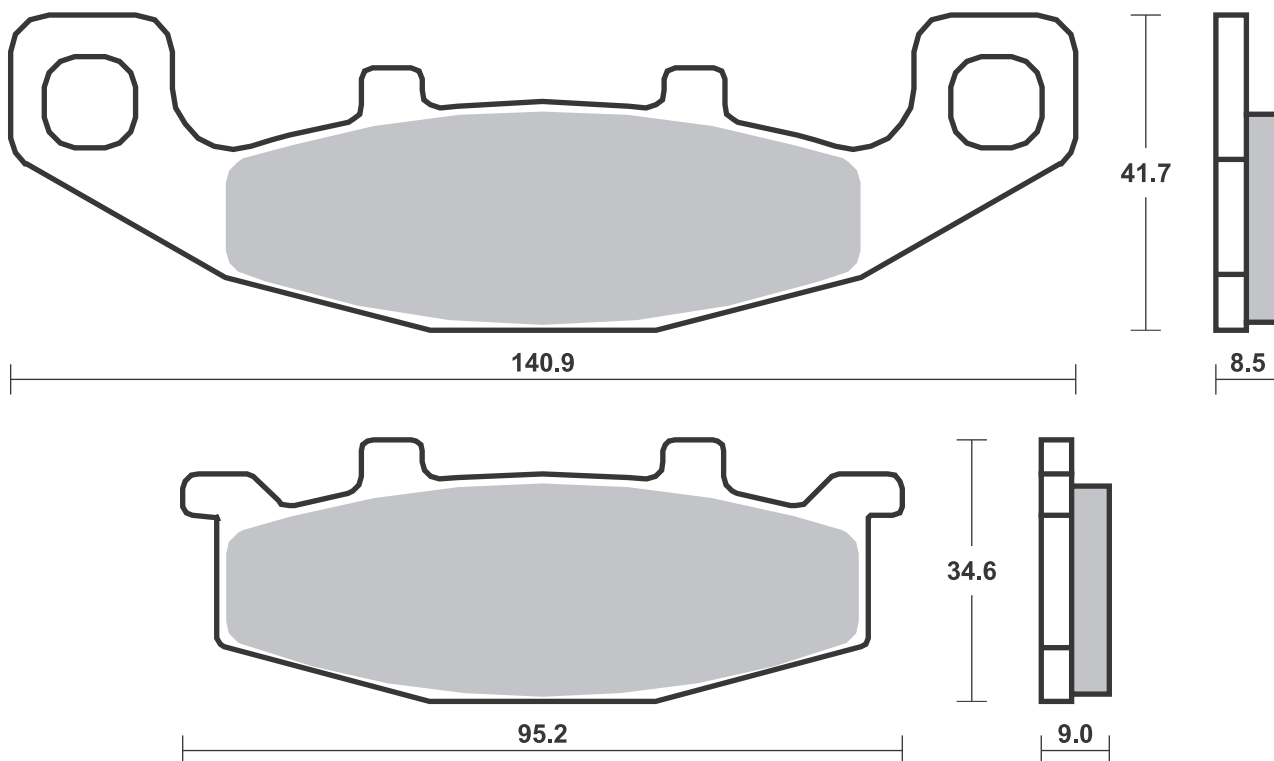





Available compounds

**HF**

**SBS 598**

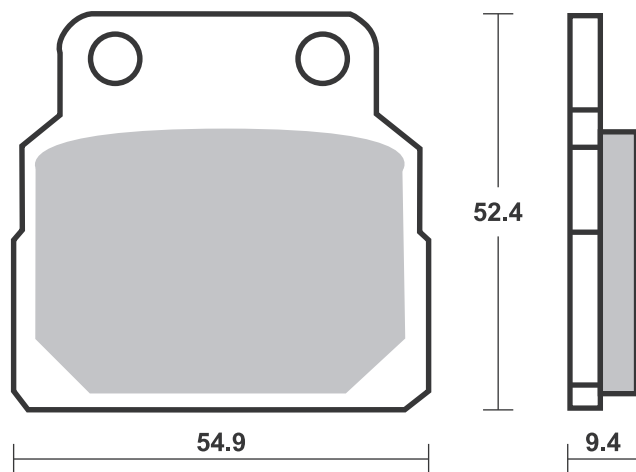

Available compounds

**RQ**

**SBS 599**

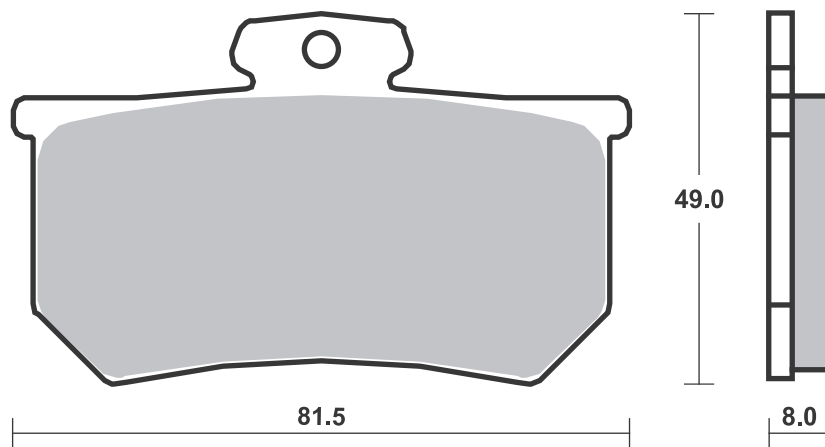

Available compounds

**HF • HS**

**SBS 600**

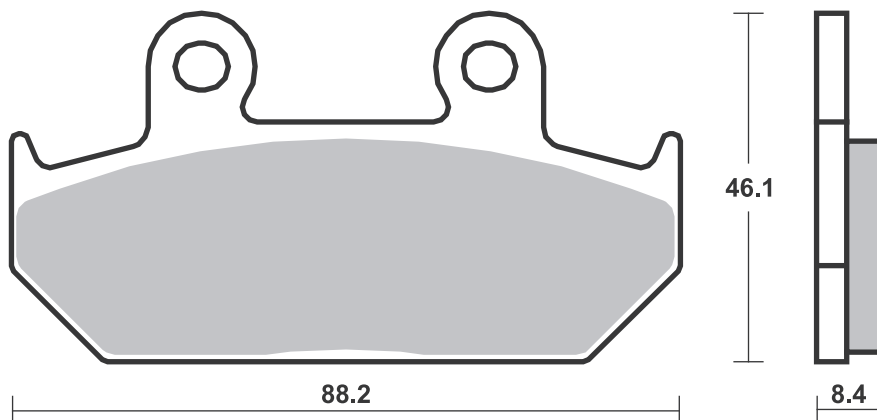

Applications

**SBS 601** Recommended compound



<b>GILERA</b>		
125 Crono	92-95	<b>HF</b>
125 Freestyle	92-95	<b>HF</b>
125 MX1, MRX, SP01	89-93	<b>HF</b>
125 SP02	90-94	<b>HF</b>
CX 125	91-95	<b>HF</b>
600 Nordwest	91-94	<b>HF</b>

<b>KTM</b>		
MX 250 VC, Enduro	87-90	<b>HF</b>
EXC 350	87-87	<b>HF</b>
GS 350	87-87	<b>HF</b>
MX 350	87-87	<b>HF</b>
400 Enduro	87-90	<b>HF</b>
MX 500	87-87	<b>HF</b>
LC4 550	87-89	<b>HF</b>
MX 550	87-90	<b>HF</b>



<b>KTM</b>			
EXC 600	87-87	<b>HF</b>	<b>HF</b>
LC4 600	88-91	<b>HF</b>	<b>HF</b>
LC4 600 Enduro	88-91	<b>HF</b>	<b>HF</b>
MC 600	88-88	<b>HF</b>	<b>HF</b>
MX 600	87-87	<b>HF</b>	<b>HF</b>

**SBS 602** Recommended compound



<b>KAWASAKI</b>		
KX 125	87-88	<b>HF</b>
KX 250	87-88	<b>HF</b>
KX 500	87-88	<b>HF</b>
KLR 650	87-94	<b>HF</b>

Available compounds

HF • RST

SBS 601

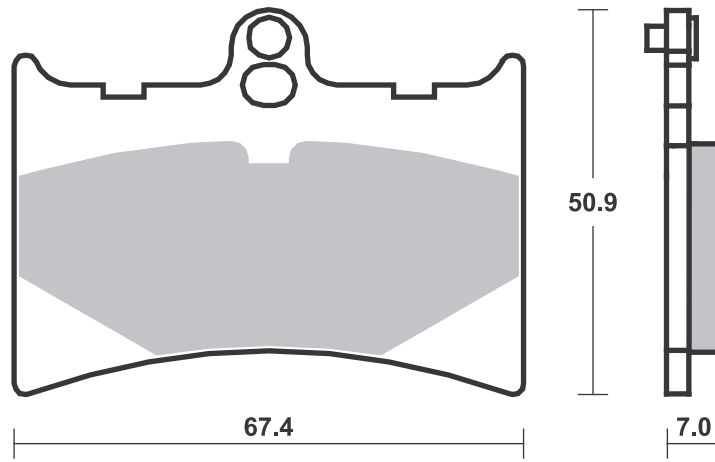

Available compounds

HF

SBS 602

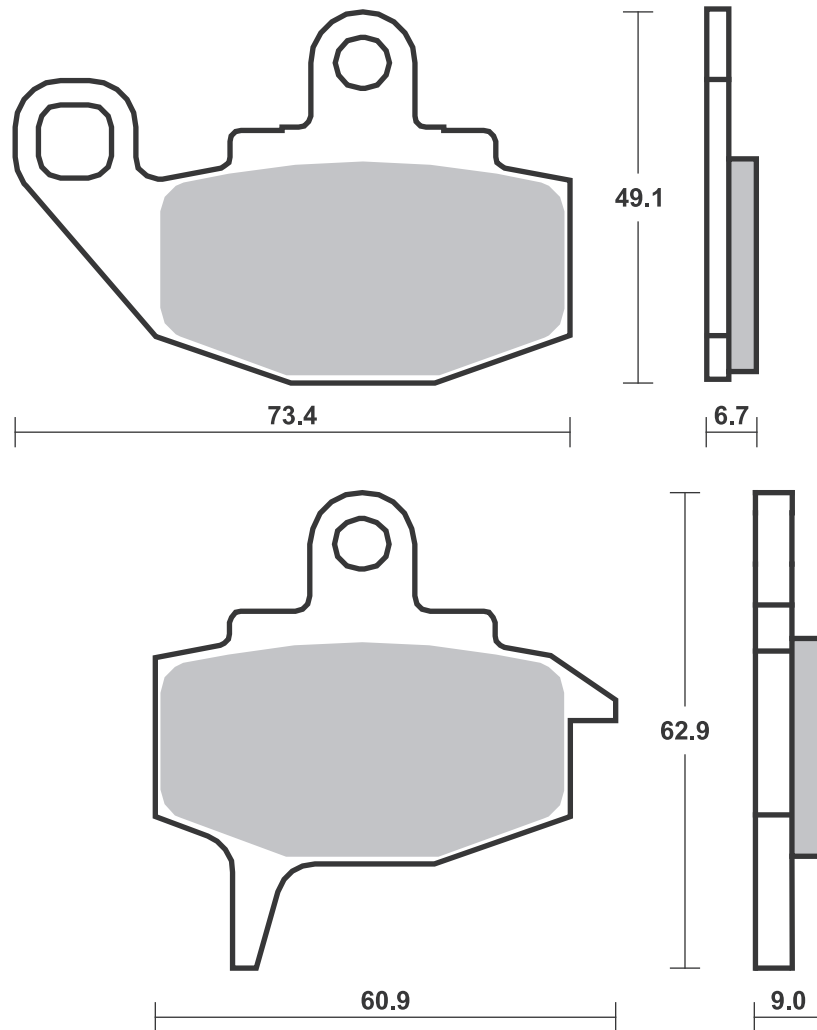



Available compounds

HF • SI • RSI

SBS 603

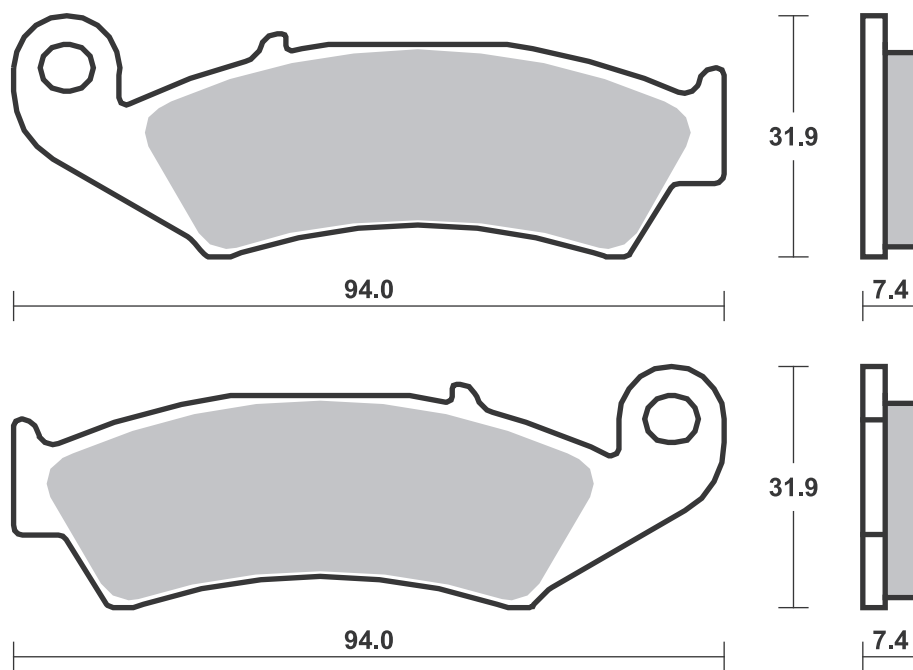

Available compounds

HF • RQ • CS • SI • RSI

SBS 604

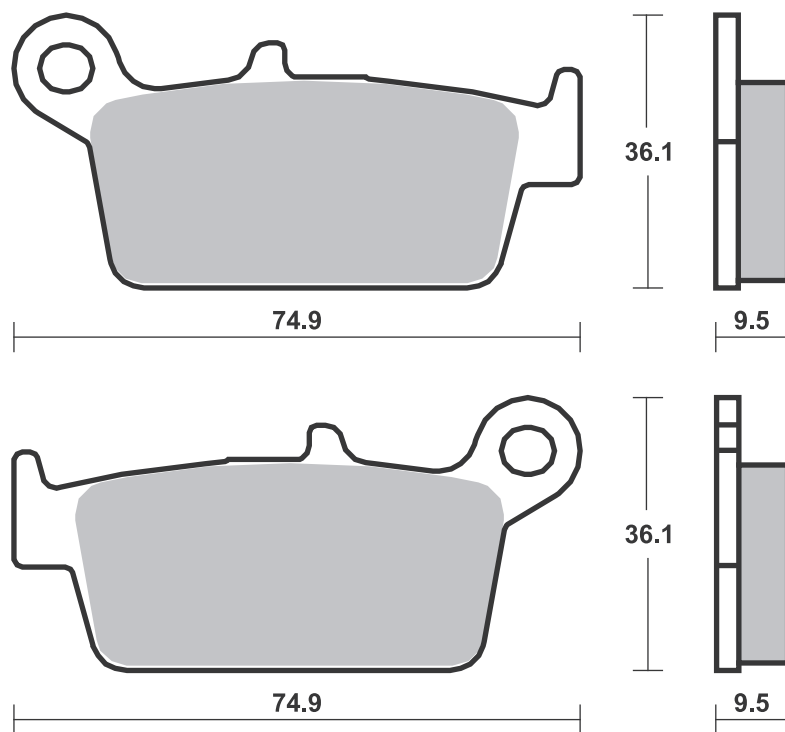



Available compounds

**HF • RQ • CS • SI • RSI**

**SBS 604**

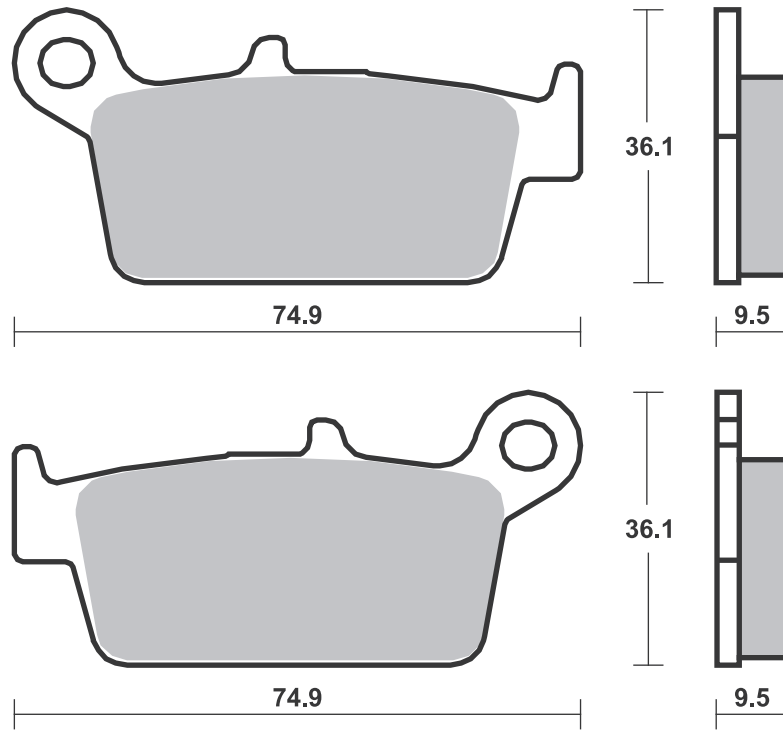

Available compounds

**HF**

**SBS 606**

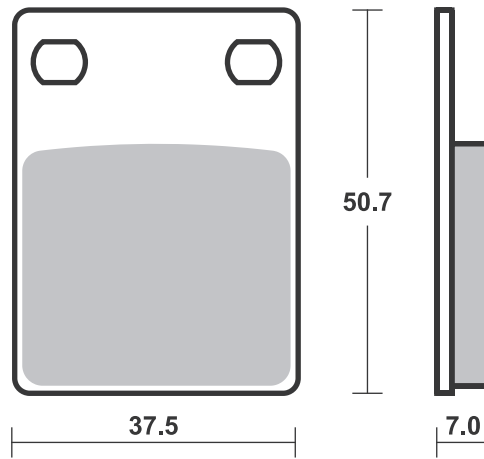





Available compounds

HF

SBS 607

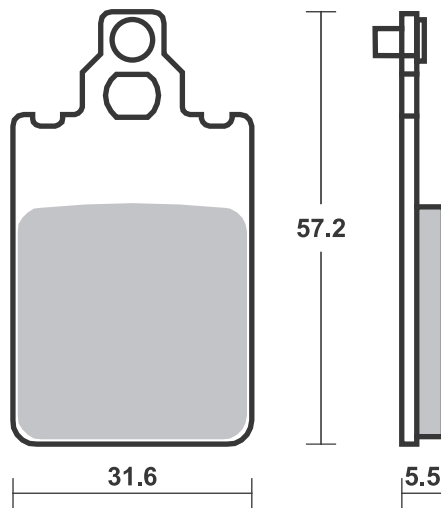

Available compounds

HF • SI • RSI

SBS 608

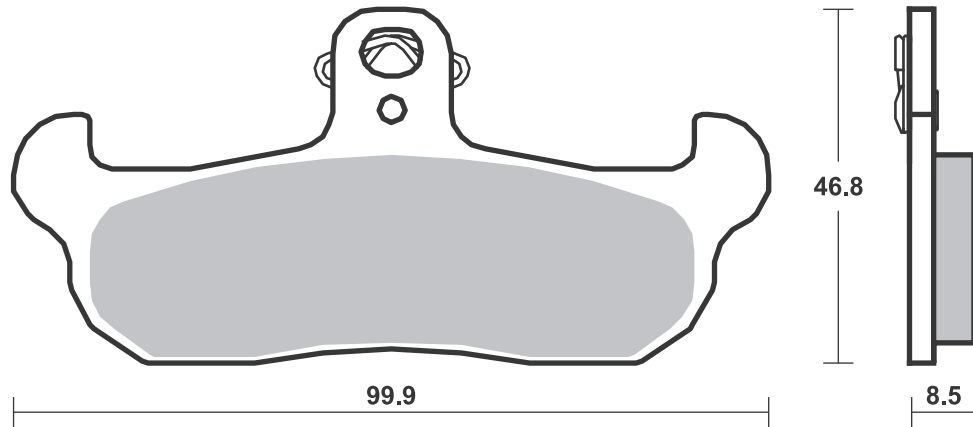

Available compounds

HF

SBS 610

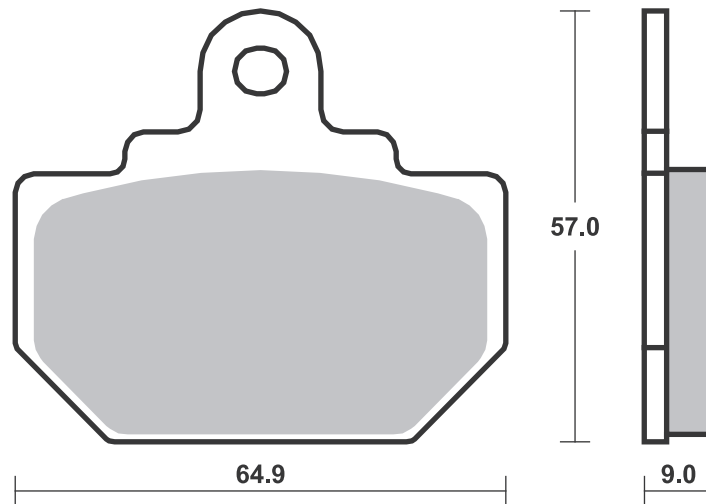



CAN-AM			
800 Commander	11-14	SI	SI
CF MOTO			
550 U-Force	15-16	SI	
550 Z-Force	15-16	SI	
800 Z-Force EX	15-15	SI	
DERBI			
DXR 200 Quad			
(Front drum)	04-05		SI
DXR 250 Quad			
(Front drum)	04-05		SI
HISUN			
HS 400 UTV	15-17	SI	
HS 500 UTV	15-17	SI	
HS 700 UTV	15-17	SI	
HS 700 UTV Left			
(2 cal.rear)	15-17	SI	SI
HS 800 UTV (2 cal.rear)	15-17	SI	SI
HONDA			
NSR 150	02-02		HF
HUSQVARNA			
all models CR, TC,TE,WR	92-94	SI	
HYOSUNG			
125 Aquila	00-04	HF	
KAWASAKI			
KLX 125	10-14	HF	
KLX 125 D-Tracker	10-14	HF	
KX 125	89-93	RSI	
KLX 140 , L	08-21	SI	
KLX 150 D-Tracker	16-18	HF	
KLX 150 L	14-15	HF	
KDX 200	93-93	SI	
KLX 230	19-22	HF	
KLX 230 R	22-22	HF	
KLX 230 SE	22-22	HF	
KDX 250 SR	91-94	SI	
KLX 250	14-18	HF	
KLX 250 Camo	18-18	HF	
KLX 250 S	09-14	HF	
KLX 250 SF	09-10	HF	
KX 250	89-93	RSI	
KLF 300 Bayou 4x4	89-05	SI	
KLF 400 Bayou	93-99	SI	
KX 500	89-93	RSI	
KLR 650	08-18	HS	
KLR 650 Camo	08-18	HS	
KVF 650 Brute Force			
4x4i	05-11	SI	
KRF 750 Teryx 4x4	08-13	SI	
KVF 750 Brute Force			
4x4i	05-15	SI	
800 Mule Pro FX	15-17	SI	
KRF 800 Teryx			
BEF/CEF/DEF	14-17	SI	
KRT 800 Teryx 4			
BEF/CEF/DEF	14-17	SI	
ZX 1000 H2 SX	18-19		LS
ZX 1000 H2 SX SE	18-19		LS
ZX 1000 H2 SX SE+	19-21		LS



SUZUKI			
RM 125	87-87	SI	
RM 125	88-90	RSI	
TS 125	89-96	HF	
DR 250	90-95	HF	
RM 250	87-90	RSI	
RMX 250	89-95	RSI	
LT-F 300 King Quad	02-02	SI	
DR 350	90-99	HF	
LT-R 450	06-12	SI	
LT-A 500 FY			
Quadmaster	00-08	SI	
LT-F 500 F	98-07	SI	
RM 500	88-89	RSI	
TRIUMPH			
750 Trident	91-98	HS	LS
800 America	03-06		LS
800 Bonneville	01-04		LS
800 Bonneville			
America	02-06		LS
800 Bonneville			
T100			
Centennial			
Edition	02-04		LS
800 Bonneville			
T100			
Paul Smith	06-08		LS
800 Speedmaster	03-04		LS
900 America	07-16		LS
900 Bonneville	09-11		LS
900 Bonneville			
Newchurch	15-15		LS
900 Bonneville SE	09-13		LS
900 Bonneville			
Spirit	15-15		LS
900 Bonneville			
Street Cup	17-18		LS
900 Bonneville			
T100	05-20		LS
900 Bonneville			
T100 Black	16-20		LS
900 Bonneville			
T214	15-15		LS
900 Daytona,			
Sprint	93-93	HS	LS
900 Scrambler	06-16		LS
900 Speedmaster	05-15		LS
900 Street Cup	17-20		LS
900 Street			
Scrambler	17-20		LS
900 Street Twin	16-20		LS
900 T100 Bud			
Ekins	20-20		LS
900 Thruxton	04-05		LS
900 Thruxton Ace	15-15		LS
900 Tiger	93-98	HS	LS
900 Trident	91-98	HS	LS
900 Trophy	91-95	HS	LS
T509 900 Speed Triple	97-01		LS
T595 950 Daytona	96-98		LS
955 Daytona			
Centennial	02-04		LS
955 Daytona to			
VIN 132512	99-06		LS
955 Speed Triple	99-06		LS
955 Sprint RS	00-05		LS
955 Sprint ST	99-04		LS



TRIUMPH			
1000 Trophy	91-95	HS	LS
1050 Speed 94	15-16		LS
1050 Speed 94R	15-16		LS
1050 Speed Triple	05-15		LS
1050 Speed Triple R	12-18		LS
1050 Speed Triple			
RS	16-20		LS
1050 Speed Triple S	16-20		LS
1050 Sprint GT ABS	10-15		LS
1050 Sprint GT SE			
ABS	10-15		LS
1050 Sprint ST	05-11		LS
1050 Tiger Sport	15-19		LS
1200 Bonneville			
T120	16-20		LS
1200 Bonneville			
T120 Ace	19-20		LS
1200 Bonneville			
T120 Black	16-20		LS
1200 Bonneville			
T120			
Diamond Ed.	19-20		LS
1200 Speed Twin	20-20		LS
1200 T120 Bud			
Ekins	20-20		LS
1200 Thruxton	16-19		LS
1200 Thruxton R	16-19		LS
1200 Thruxton RS	20-20		LS
1200 Tiger Explorer	12-17		LS
1200 Tiger XCA	18-20		LS
1200 Tiger XCX	18-20		LS
1200 Tiger XR	18-19		LS
1200 Tiger XRT	18-20		LS
1200 Tiger XRX	18-20		LS
1200 Tiger XRX Low	18-20		LS
1200 Trophy	91-95	HS	LS
1200 Trophy SE	13-18		LS
YAMAHA			
WR 125	91-97	SI	
YZ 125	89-97	RSI	
WR 200	91-92	SI	
TT-R 230	05-05	SI	
TT 250	93-03	SI	
WR 250	90-97	SI	
YZ 250	89-89	RSI	
YZ 250 A	90-90	RSI	
YZ 250 B1-J1	91-97	RSI	
YZ 250 WRA,WRB	90-91	RSI	
TT 350	95-00	SI	
YFZ 450 S	04-09	SI	
YXR 450 Rhino	06-09	SI	
WR 500 B	91-91	SI	
WR 500 ZD,ZE	92-93	SI	
660 Rhino	05-08	SI	
YFM 700 R Raptor	06-08	SI	
YFM 700 Raptor	09-14	SI	
YXR 700 Rhino	08-14	SI	SI

Available compounds

HF • HS • LS • RQ • SI • RSI • PSI

SBS 611

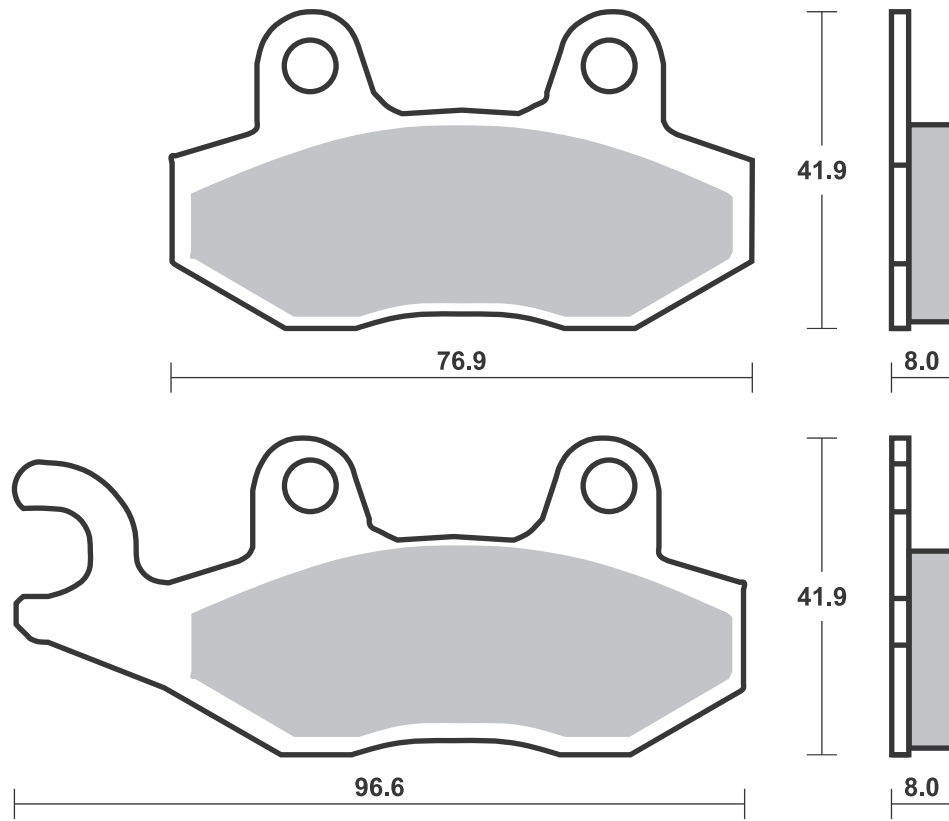



Available compounds

HF • HS • DCC

SBS 613

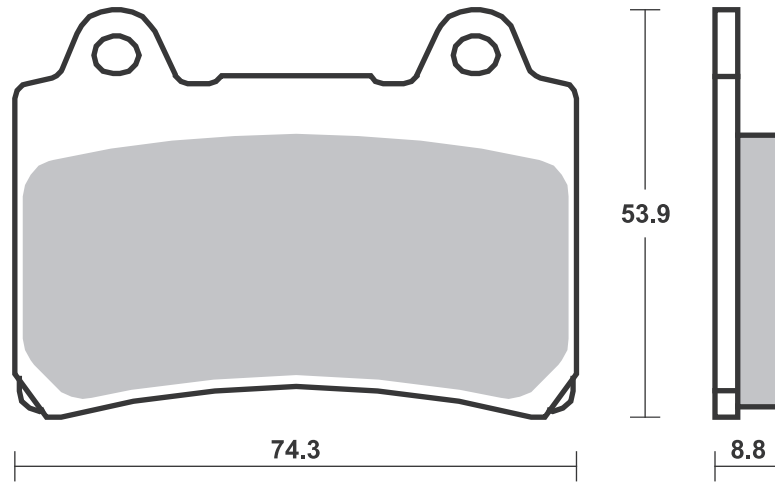

Available compounds

HF • LS • RQ

SBS 614

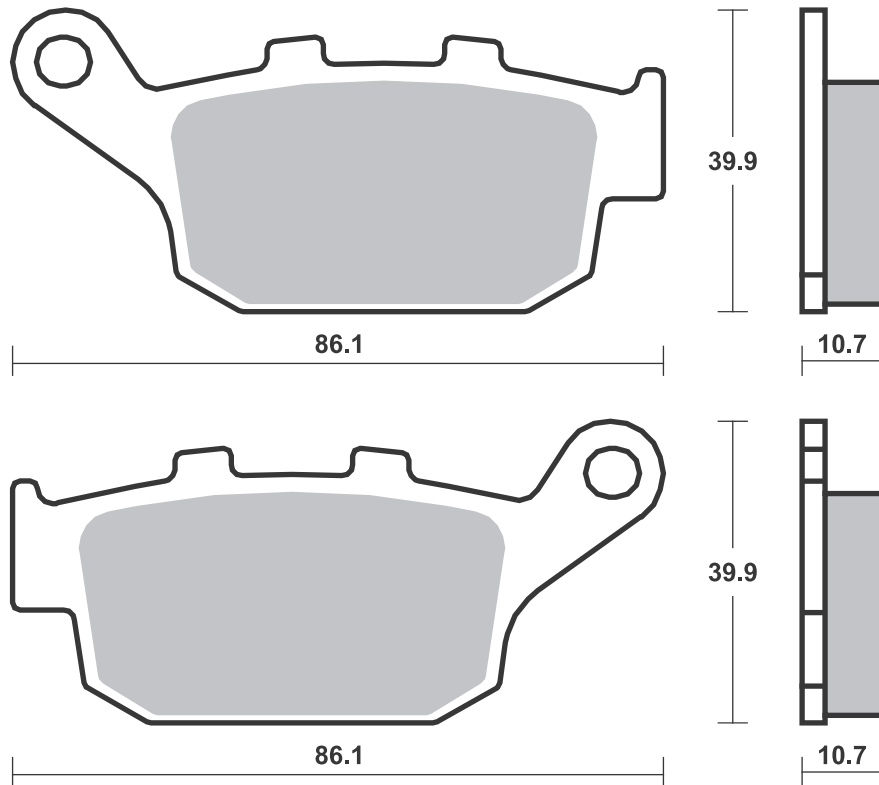

# Applications

## SBS 615 Recommended compound



### KAWASAKI

EX	250 R Ninja	88-07	HF
EX	500	94-96	HS
ZR	550 Zephyr	90-92	LS

### SUZUKI

GSX	1100 G	94-95	LS
-----	--------	-------	----

## SBS 616 Recommended compound



### YAMAHA

XV	250 Virago	89-94	HF
XV	535 Virago	87-94	HF

## SBS 617 Recommended compound



### YAMAHA

YT	125 Tri Moto	80-81	HF
----	--------------	-------	----

Brake Pad 1:1 Drawings,  
Compounds, Fitments

Available compounds

**HF • HS • LS • RQ**

**SBS 615**

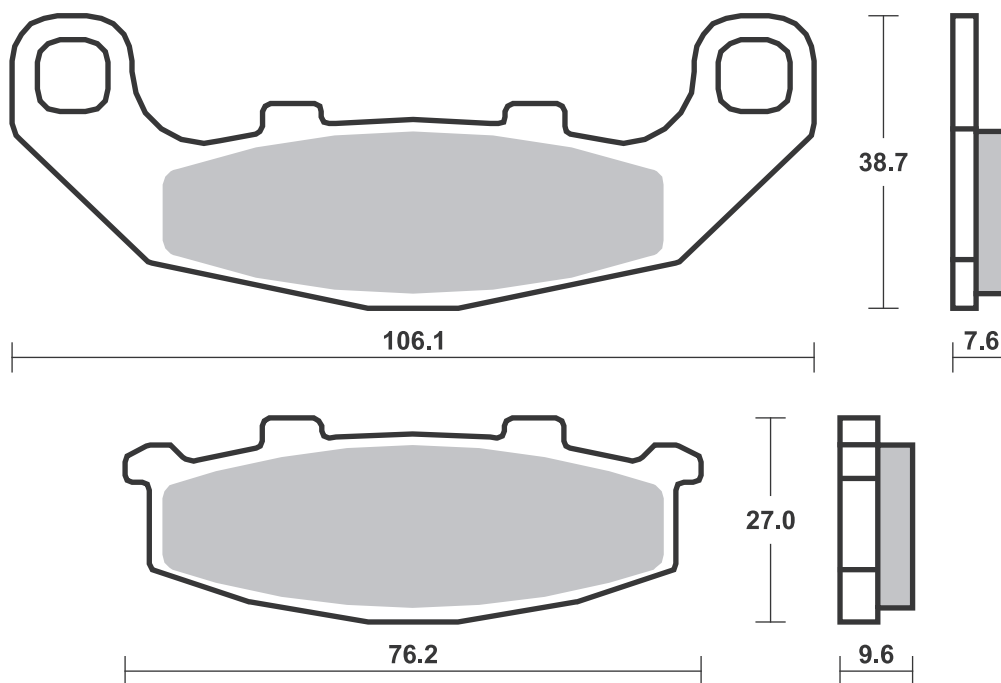

Available compounds

**HF**

**SBS 616**

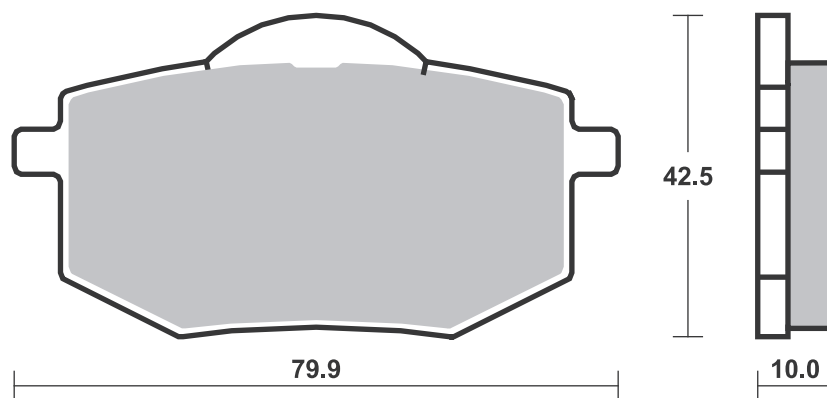

Available compounds

**HF**

**SBS 617**

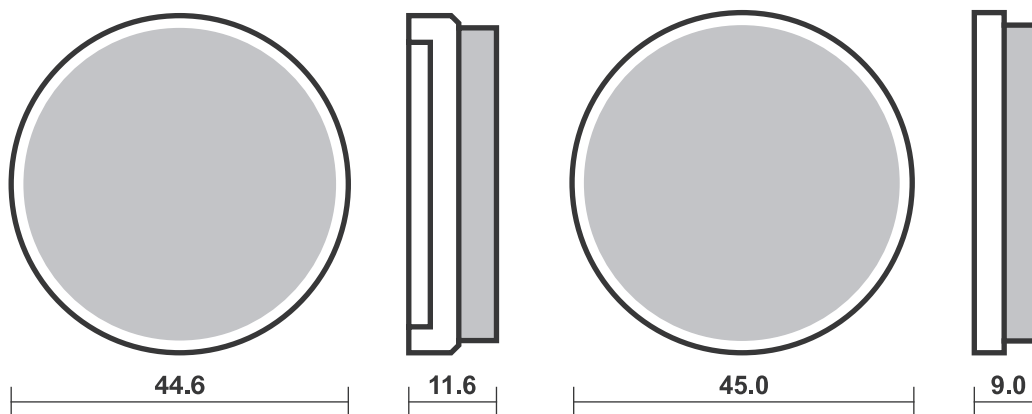

**SBS 618** Recommended compound



<b>HONDA</b>			
R	50 Monkey	88-88	<b>HF</b>
RS	125	95-03	<b>RQ</b>
RS	125 R	91-94	<b>HF</b>
RS	250 R	93-93	<b>RQ</b>
<b>MORIWAKI</b>			
MD	250	09-09	<b>RQ</b>
<b>SYM</b>			
	50 Feel-big	98-98	<b>HF</b>
	50 Pure	98-98	<b>HF</b>

**SBS 619** Recommended compound



<b>YAMAHA</b>			
BW	50	03-05	<b>HF</b>

**SBS 620** Recommended compound



<b>SUZUKI</b>			
GSX	600 Katana	88-89	<b>HF</b>
GSX	600 Katana	90-97	<b>HS</b>
GSX	750 Katana	89-96	<b>HS</b>
VX	800 L-P	90-93	<b>LS</b>
GSX	1100 F	93-96	<b>HS</b>
GL	1400 Cavalcade	87-88	<b>HF</b>

Brake Pad 1:1 Drawings, Compounds, Fitments



Available compounds

HF • RQ

SBS 618

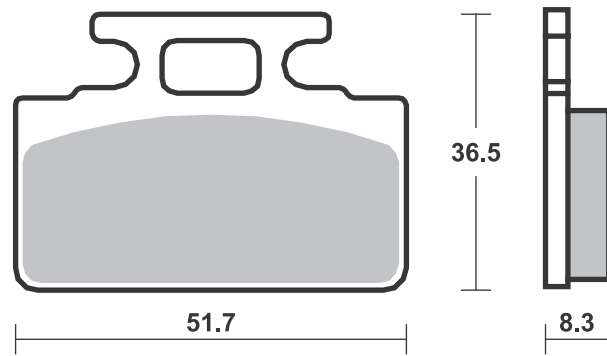

Available compounds

HF

SBS 619

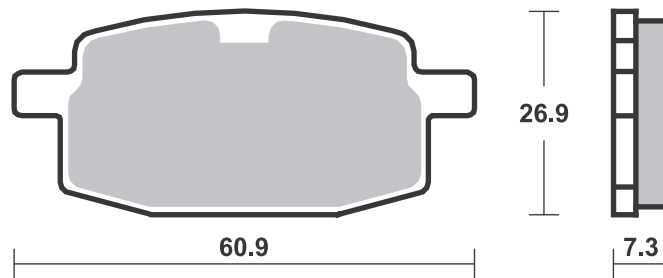

Available compounds

HF • HS • LS

SBS 620

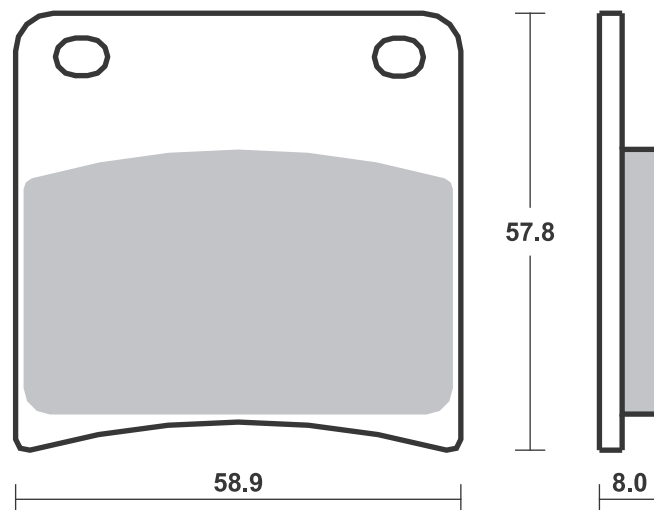



Available compounds

HF

SBS 621

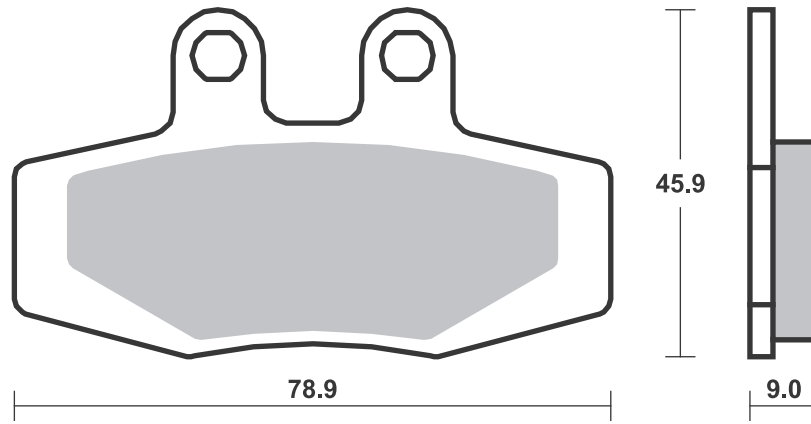

Available compounds

HF • HS • DC • RST • DCC

SBS 622

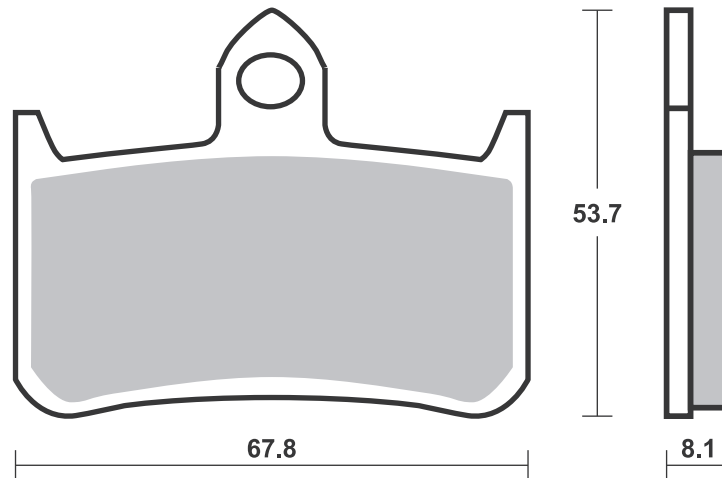



Available compounds

HF • LS • RQ

SBS 623

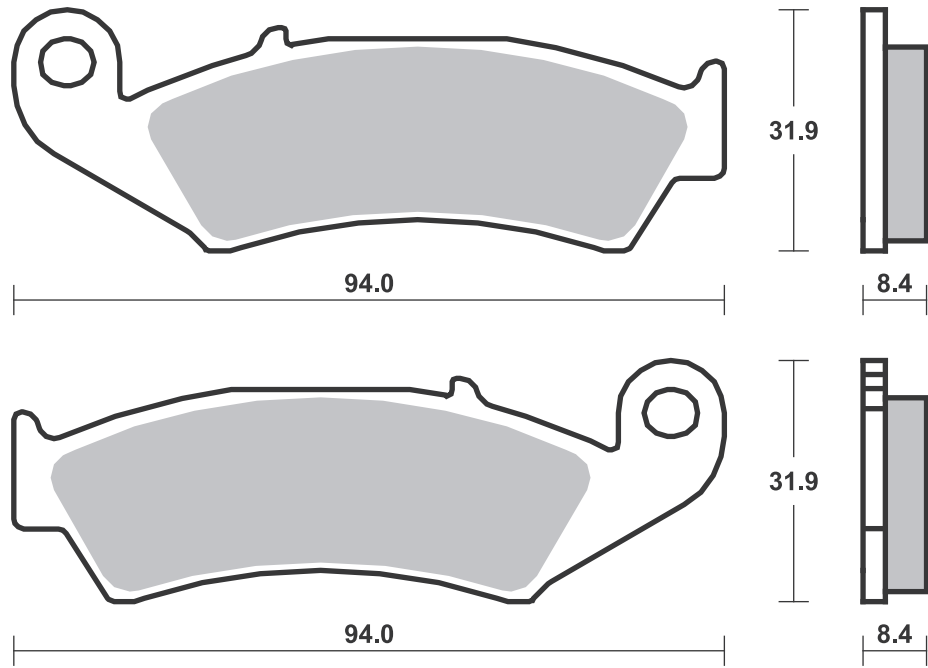

Available compounds

HF • HS • SP • DC • RST • DCC

SBS 624

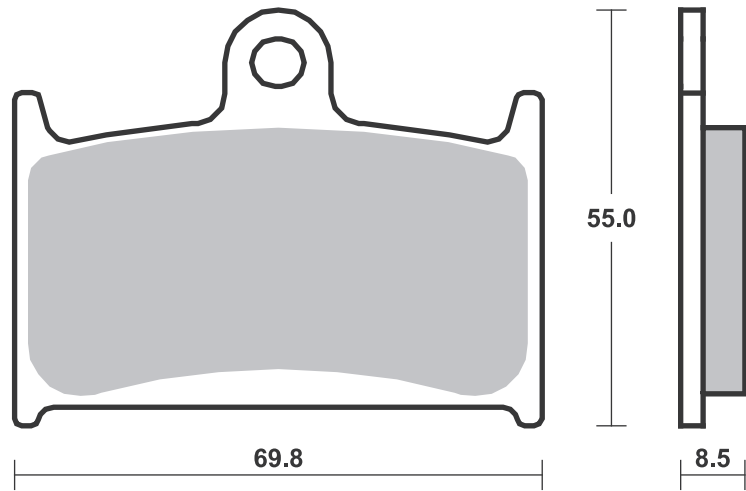



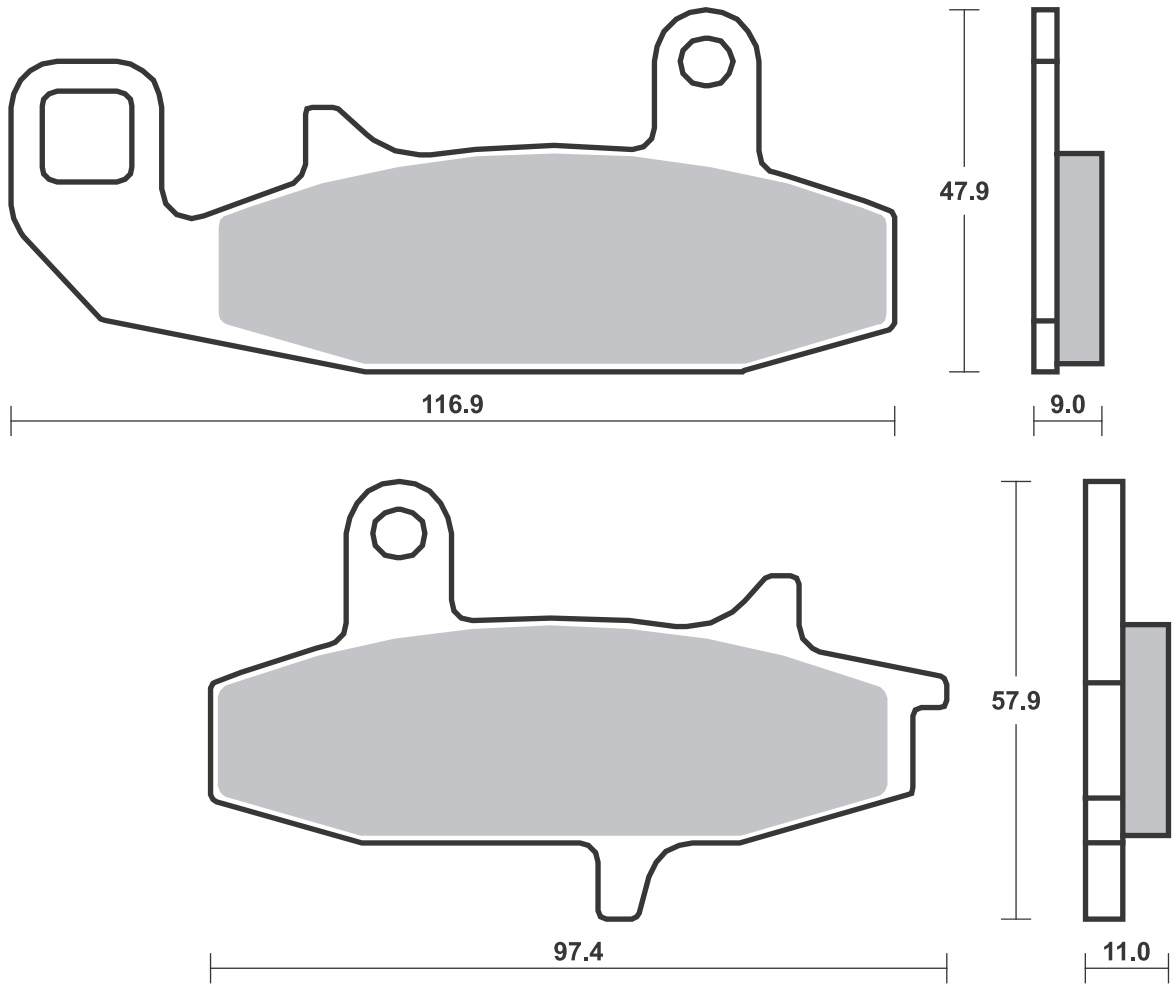



<b>BUELL</b>		
500 Blast	01-09	<b>HF</b>

<b>CAGIVA</b>		
900 Gran Canyon	99-04	<b>HS</b>
1000 Navigator, T	00-05	<b>HS</b>

<b>HONDA</b>		
RS 125 R	91-94	<b>HF</b>
CBR 250 R (Nissin cal)	11-13	<b>HS</b>
CB-1 400 (CB 400 F)	89-90	<b>HS</b>
CB 599	04-04	<b>HS</b>
CBR 600 F	11-13	<b>HS</b>
CBR 600 F3	95-98	<b>HS</b>
VT 600 C, Shadow	94-00	<b>HS</b>
VT 600 CD Shadow		
VLX	94-00	<b>HS</b>
CB 650 F	14-19	<b>HS</b>
CBR 650 F	14-20	<b>HS</b>
FMX 650 Rally	05-08	<b>HS</b>
NT 650 Hawk GT	88-91	<b>HS</b>
NC 700 S	12-13	<b>HS</b>
NC 700 X	12-13	<b>HS</b>
VFR 700 F Interceptor	88-89	<b>HS</b>
CB 750 N, F,		
Seven Fifty	92-95	<b>HS</b>
CB 750 Nighthawk	91-02	<b>HS</b>
VFR 750 F	88-98	<b>HS</b>
PC 800 Pacific Coast	89-97	<b>HS</b>
CBR 1000 F	89-92	<b>HS</b>
ST 1100 ABS-TCS	92-95	<b>HS</b>
VT 1100 C Shadow	94-96	<b>HS</b>
VT 1100 C2 Shadow		
A.C.E.	95-04	<b>HS</b>
VT 1100 C2 Shadow		
Sabre	00-05	<b>HS</b>
VT 1100 C3 Shadow		
Aero	98-04	<b>HS</b>
VT 1100 T Shadow	98-04	<b>HS</b>
VT 1300 CX A Fury	10-18	<b>HS</b>
VT 1300 Interstate	11-15	<b>HS</b>
VT 1300 Sabre	11-13	<b>HS</b>
VT 1300 Stateline	11-16	<b>HS</b>
VTX 1300 C	04-09	<b>HS</b>
VTX 1300 S	03-07	<b>HS</b>
GL 1500 Valkyrie	96-03	<b>HS</b>

<b>HYOSUNG</b>		
125 V2	99-11	<b>HF</b>
250 Aquila	00-09	<b>HF</b>

<b>KAWASAKI</b>		
KLE 300 Versys-X	17-20	<b>HS</b>
EX 650 Ninja KRT ABS	17-20	<b>HS</b>
EX 650 Ninja		
Performance		
ABS	17-20	<b>HS</b>
EX 650 Ninja Tourer		
ABS	17-20	<b>HS</b>
KLE 650 Versys	15-21	<b>HS</b>
KLE 650 Versys LT	15-16	<b>HS</b>
Z 650 ABS	17-19	<b>HS</b>
Z 750 , ABS	07-12	<b>HS</b>
Z 800 e	13-16	<b>HS</b>

<b>KYMCO</b>		
250 Venox	01-14	<b>HF</b>



<b>SUZUKI</b>		
DL 250 V-Strom	17-19	<b>HF</b>
GW 250 Inazuma	12-19	<b>HS</b>
GW 250 Inazuma F	15-19	<b>HS</b>
GSF 600 Bandit	95-99	<b>HS</b>
RF 600 R	93-96	<b>HS</b>
C 1500 T Intruder	13-18	<b>HS</b>
C90 1500 Boulevard		
B.O.S.S.	13-18	<b>HS</b>

<b>SWM</b>		
440 Gran Milano	15-17	<b>HS</b>
440 Gran Turismo	15-17	<b>HS</b>
440 Silver Vase	15-17	<b>HS</b>

<b>TRIUMPH</b>		
660 Street Triple S	17-20	<b>HS</b>
660 Tiger Sport	22-22	<b>SP</b>
660 Tiger Sport	22-22	<b>SP</b>
660 Trident	21-22	<b>SP</b>
675 Street Triple	08-17	<b>HS</b>
765 Street Triple S	17-20	<b>HS</b>
800 America	03-06	<b>HS</b>
800 Bonneville	01-04	<b>HS</b>
800 Bonneville		
America	02-06	<b>HS</b>
800 Bonneville		
T100		
Centennial		
Edition	02-04	<b>HS</b>
800 Bonneville		
T100		
Paul Smith	06-08	<b>HS</b>
800 Speedmaster	03-04	<b>HS</b>
800 Tiger	11-14	<b>HS</b>
800 Tiger XC	11-17	<b>HS</b>
800 Tiger XC ABS	12-14	<b>HS</b>
800 Tiger XCA	15-17	<b>HS</b>
800 Tiger XCR	15-17	<b>HS</b>
800 Tiger XR	15-18	<b>HS</b>
800 Tiger XRT	15-17	<b>HS</b>
800 Tiger XRX	15-17	<b>HS</b>
900 Adventurer	96-02	<b>HS</b>
900 America	07-16	<b>HS</b>
900 Bonneville	05-11	<b>HS</b>
900 Bonneville		
Newchurch	15-15	<b>HS</b>
900 Bonneville SE	09-13	<b>HS</b>
900 Bonneville		
Spirit	15-15	<b>HS</b>
900 Bonneville		
Street Cup	17-18	<b>HS</b>
900 Bonneville		
T100	05-20	<b>HS</b>
900 Bonneville		
T100 Black	16-20	<b>HS</b>
900 Bonneville		
T214	15-15	<b>HS</b>
900 Legend TT	99-01	<b>HS</b>
900 Scrambler	06-16	<b>HS</b>
900 Speedmaster	05-15	<b>HS</b>
900 Street Cup	17-20	<b>HS</b>
900 Street		
Scrambler	17-18	<b>HS</b>
900 Street Twin	16-18	<b>HS</b>
900 T100 Bud		
Ekins	20-20	<b>HS</b>
900 Thruxton	04-05	<b>HS</b>



<b>TRIUMPH</b>		
900 Thruxton Ace	15-15	<b>HS</b>
900 Thunderbird	96-05	<b>HS</b>
900 Thunderbird		
Sport	03-04	<b>HS</b>
900 Tiger	99-00	<b>HS</b>
955 Tiger	01-06	<b>HS</b>
955 Tiger	04-06	<b>HS</b>
1200 Bonneville		
Bobber	17-20	<b>HS</b>
1200 Bonneville		
T120	16-20	<b>HS</b>
1200 Bonneville		
T120 Ace	19-20	<b>HS</b>
1200 Bonneville		
T120 Black	16-20	<b>HS</b>
1200 Bonneville		
T120		
Diamond Ed.	19-20	<b>HS</b>
1200 T120 Bud		
Ekins	20-20	<b>HS</b>
1200 Thruxton	16-19	<b>HS</b>

<b>YAMAHA</b>		
WR 125 R, XY	09-16	<b>HF</b>
WR 250 X	08-16	<b>HS</b>



Available compounds

HF • HS • LS • SP • DC • RST • DCC

SBS 627

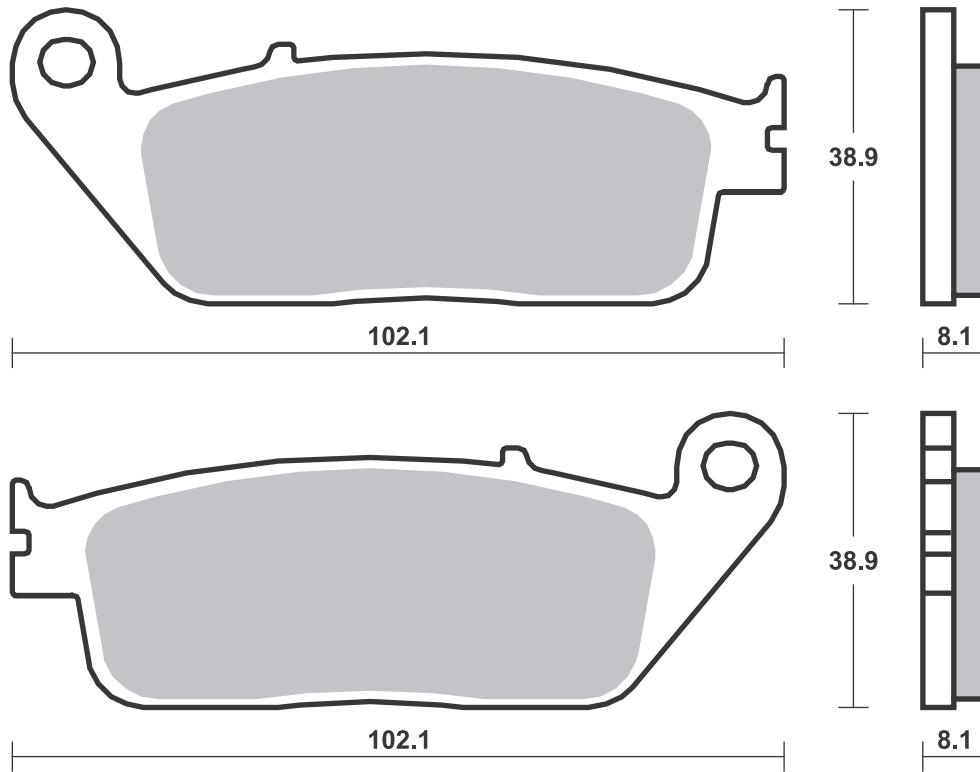

# Applications

## SBS 630 Recommended compound



<b>HONDA</b>			
DN-01	680	08-11	<b>LS</b>
VF	750 C,		
	CD Magna	94-98	<b>HS</b>
VFR	750 F	88-98	<b>LS</b>
CBR	1000 F	89-92	<b>LS</b>
CTX	1300	14-18	<b>LS</b>
GL	1500 Valkyrie	96-03	<b>LS</b>

<b>INDIAN</b>			
	1800 Challenger	20-20	<b>H.LS</b>
	1800 Challenger		
	Dark Horse	20-20	<b>H.LS</b>
	1800 Challenger		
	Limited	20-20	<b>H.LS</b>
	1800 Chief	15-18	<b>H.LS</b>
	1800 Chief Classic	14-18	<b>H.LS</b>
	1800 Chief Dark		
	Horse	15-19	<b>H.LS</b>
	1800 Chief Vintage	14-19	<b>H.LS</b>
	1800 Chieftain	14-18	<b>H.LS</b>
	1800 Chieftain		
	Classic	15-18	<b>H.LS</b>
	1800 Chieftain		
	Dark Horse	15-18	<b>H.LS</b>
	1800 Chieftain		
	Limited	15-18	<b>H.LS</b>
	1800 Dark Horse	16-18	<b>H.LS</b>
	1800 Roadmaster	15-19	<b>H.LS</b>
	1800 Roadmaster		
	Classic	15-18	<b>H.LS</b>



<b>INDIAN</b>			
	1800 Roadmaster		
	Elite	15-18	<b>H.LS</b>
	1800 Springfield	16-19	<b>H.LS</b>
	1800 Springfield		
	Dark Horse	15-20	<b>H.LS</b>

<b>TRIUMPH</b>			
	900 Adventurer	96-02	<b>LS</b>
	900 Legend TT	99-01	<b>LS</b>
	900 Thunderbird	96-05	<b>LS</b>
	900 Thunderbird		
	Sport	03-04	<b>LS</b>
	900 Tiger	99-00	<b>LS</b>

<b>VICTORY</b>			
	1634 Hammer	08-08	<b>H.LS</b>
	1634 Kingpin		
	all models	08-12	<b>H.LS</b>
	1634 Vegas	08-17	<b>H.LS</b>
	1634 Vegas 8-Ball	08-17	<b>H.LS</b>
	1634 Vegas Jackpot	08-08	<b>H.LS</b>
	1731 Boardwalk	13-15	<b>H.LS</b>
	1731 Cross Country	10-17	<b>H.LS</b>
	1731 Cross Country		
	8-Ball	14-16	<b>H.LS</b>
	1731 Cross Country		
	Tour	12-17	<b>H.LS</b>
	1731 Cross Roads	10-12	<b>H.LS</b>
	1731 Cross Roads		
	8-Ball	14-14	<b>H.LS</b>



<b>VICTORY</b>			
	1731 Cross Roads		
	Classic	14-14	<b>H.LS</b>
	1731 Gunner	15-17	<b>H.LS</b>
	1731 Hammer	09-11	<b>H.LS</b>
	1731 Hammer		
	8-Ball	10-16	<b>H.LS</b>
	1731 Hammer S	09-17	<b>H.LS</b>
	1731 Hard-Ball	12-13	<b>H.LS</b>
	1731 High-Ball	12-17	<b>H.LS</b>
	1731 Jackpot	10-16	<b>H.LS</b>
	1731 Judge	13-17	<b>H.LS</b>
	1731 Kingpin	10-12	<b>H.LS</b>
	1731 Kingpin 8-Ball	10-11	<b>H.LS</b>
	1731 Magnum	15-17	<b>H.LS</b>
	1731 Magnum X-1	15-17	<b>H.LS</b>
	1731 Vegas	10-17	<b>H.LS</b>
	1731 Vegas 8-Ball	10-17	<b>H.LS</b>
	1731 Vegas Jackpot	09-09	<b>H.LS</b>
	1731 Vision		
	all models	08-17	<b>H.LS</b>

## SBS 631 Recommended compound



<b>BERINGER</b>			
	4 Piston Caliper		

<b>HUSABERG</b>			
FS	400 e, c	01-03	<b>RSI</b>
FS	450 e, c	03-05	<b>RSI</b>
FS	650 e, c	01-05	<b>RSI</b>

<b>KAWASAKI</b>			
ZR	400 Zephyr	97-01	<b>HS</b>
	600 R, Ninja	89-96	<b>HF</b>
ZX	600 Ninja	90-93	<b>HS</b>
ZX-6R	600 (Ninja ZX6)	93-97	<b>HS</b>
ZX-6R	600 (Ninja ZX6R)	95-97	<b>HS</b>
ZX-6R	600 (ZX6)	90-93	<b>HS</b>
ZX-7R	750 Ninja	89-95	<b>HS</b>
ZX-9R	900 Ninja	94-95	<b>HS</b>
KLE	1000 Versys	12-18	<b>SP</b>
KLE	1000 Versys ABS	15-18	<b>SP</b>
KLE	1000 Versys LT	15-16	<b>SP</b>
ZR	1100 Zephyr	92-95	<b>HS</b>
ZX	1100	93-97	<b>HS</b>
ZZR	1100	90-01	<b>HS</b>
ZZR	1200	02-04	<b>HS</b>
VN	1700 Vulcan		
	Voyager	09-16	<b>HS</b>
VN	2000 Vulcan	04-10	<b>HS</b>

<b>MOTO-MASTER</b>			
	Supermoto Racing Caliper		



<b>SUZUKI</b>			
GSF	400 Bandit	93-97	<b>HS</b>
GSR	600	06-10	<b>HS</b>
GSX-R	600	97-03	<b>HS</b>
GSF	650 Bandit	07-11	<b>HS</b>
GSF	650 Bandit ABS	07-12	<b>HS</b>
GSF	650 S Bandit	07-11	<b>HS</b>
GSF	650 S Bandit ABS	07-13	<b>HS</b>
GSX	650 F	08-18	<b>HS</b>
SV	650	19-20	<b>HS</b>
SV	650 X	19-20	<b>HS</b>
GSX-R	750	00-03	<b>HS</b>
SV	1000, S	03-07	<b>HS</b>
TL	1000 S V-Twin	97-01	<b>HS</b>
GSF	1200 Bandit	06-06	<b>HS</b>
GSF	1200 S Bandit	06-06	<b>HS</b>
GSF	1250 A Bandit	07-18	<b>HS</b>
GSF	1250 Bandit	06-18	<b>HS</b>
GSF	1250 F Bandit	12-18	<b>HS</b>
GSF	1250 S Bandit	06-18	<b>HS</b>
GSF	1250 SA Bandit	07-18	<b>HS</b>
GSX	1250 FA Bandit	16-18	<b>HS</b>
GSX	1250 FA Traveller	15-16	<b>HS</b>

Available compounds

HF • HS • LS • H.HF • H.CT • H.LS

SBS 630

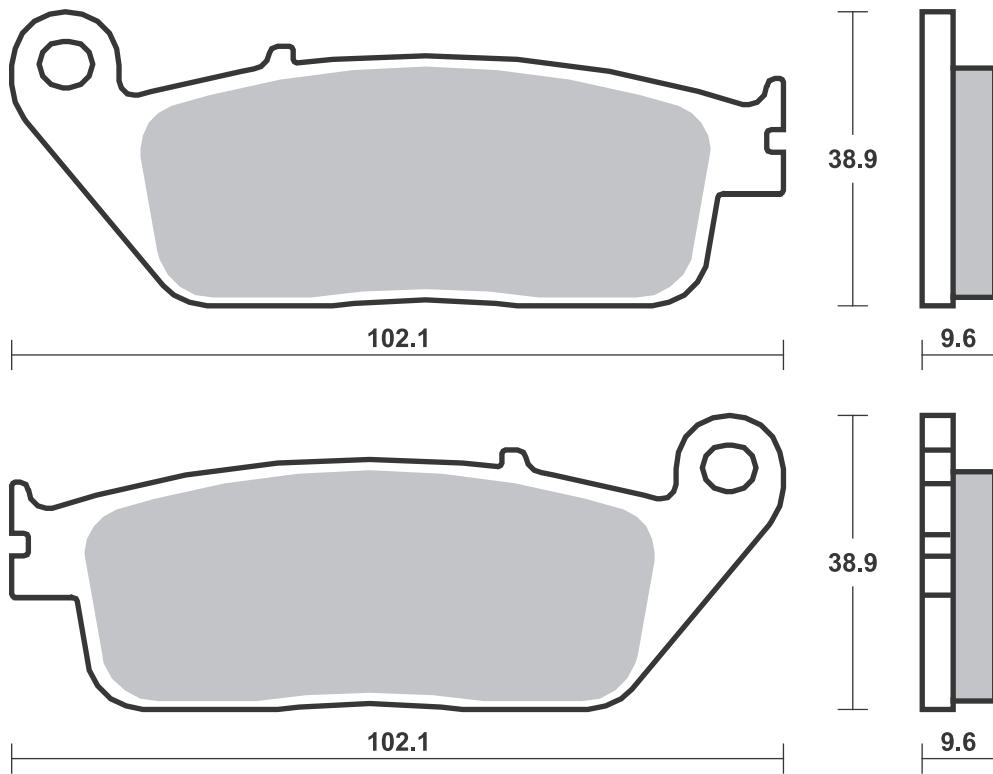

Available compounds

HF • HS • SP • DC • RST • DCC • DS-1 • RSI

SBS 631

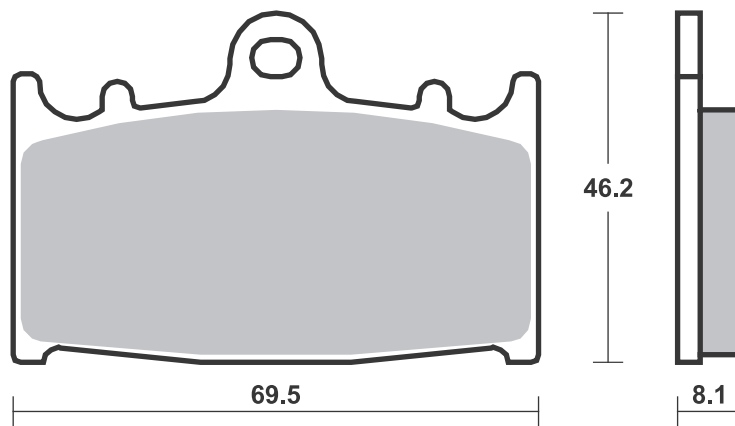

**SBS 632** Recommended compound



<b>CANNONDALE</b>			
MX	400	00-03	<b>RSI</b>
C	440 R	03-03	<b>RSI</b>
E	440, A, R	03-03	<b>RSI</b>
S	440	03-03	<b>HF</b>
X	440	03-03	<b>RSI</b>

<b>KAWASAKI</b>			
KX	125	89-94	<b>RSI</b>
KDX	200	93-99	<b>SI</b>
KDX	200 SR	89-92	<b>SI</b>
KDX	220 R	97-05	<b>SI</b>
KDX	250 SR	91-94	<b>SI</b>
KLX	250	93-96	<b>SI</b>
KX	250	89-94	<b>RSI</b>
KX	500	89-95	<b>RSI</b>
KLX	650	93-96	<b>SI</b>
KLX	650 R	93-95	<b>SI</b>

<b>SUZUKI</b>			
RM	125	89-90	<b>RSI</b>
TS	125	89-96	<b>HF</b>
DR	250	90-95	<b>HF</b>
RM	250	89-90	<b>RSI</b>

<b>YAMAHA</b>			
WR	125	91-97	<b>SI</b>
XSR	125	22-22	<b>HF</b>
YZ	125	90-95	<b>RSI</b>
WR	200	91-92	<b>SI</b>
FZ25	250	19-19	<b>HF</b>



<b>YAMAHA</b>			
TT	250	93-03	<b>SI</b>
WR	250	90-97	<b>SI</b>
XG	250 Tricker	05-11	<b>HF</b>
XT	250	08-08	<b>HF</b>
YZ	250 A	90-90	<b>RSI</b>
YZ	250 WRA,WRB	90-91	<b>RSI</b>
TT	350	95-00	<b>SI</b>
WR	500 ZD,ZE	92-93	<b>SI</b>

**SBS 633** Recommended compound



<b>TRIUMPH</b>			
	750 Daytona	91-92	<b>LS</b>
	900 Daytona	91-93	<b>LS</b>
	900 Daytona		
	Super III	94-98	<b>LS</b>
	900 Trophy	96-03	<b>LS</b>
	1000 Daytona	92-92	<b>LS</b>
	1200 Daytona	91-97	<b>LS</b>
	1200 Trophy	96-03	<b>LS</b>

Brake Pad 1:1 Drawings, Compounds, Fitments

Available compounds

HF • SI • RSI

SBS 632

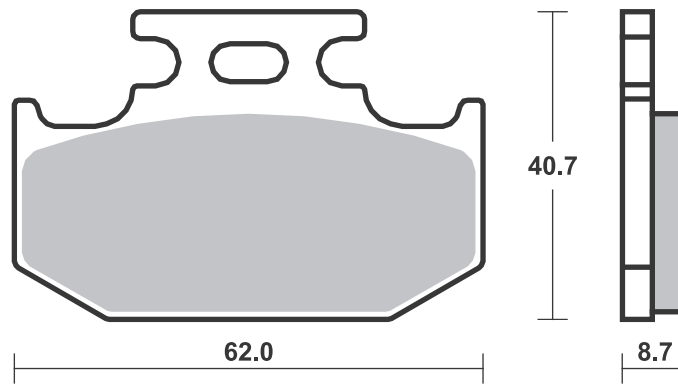

Available compounds

HF • LS • SI • RSI

SBS 633

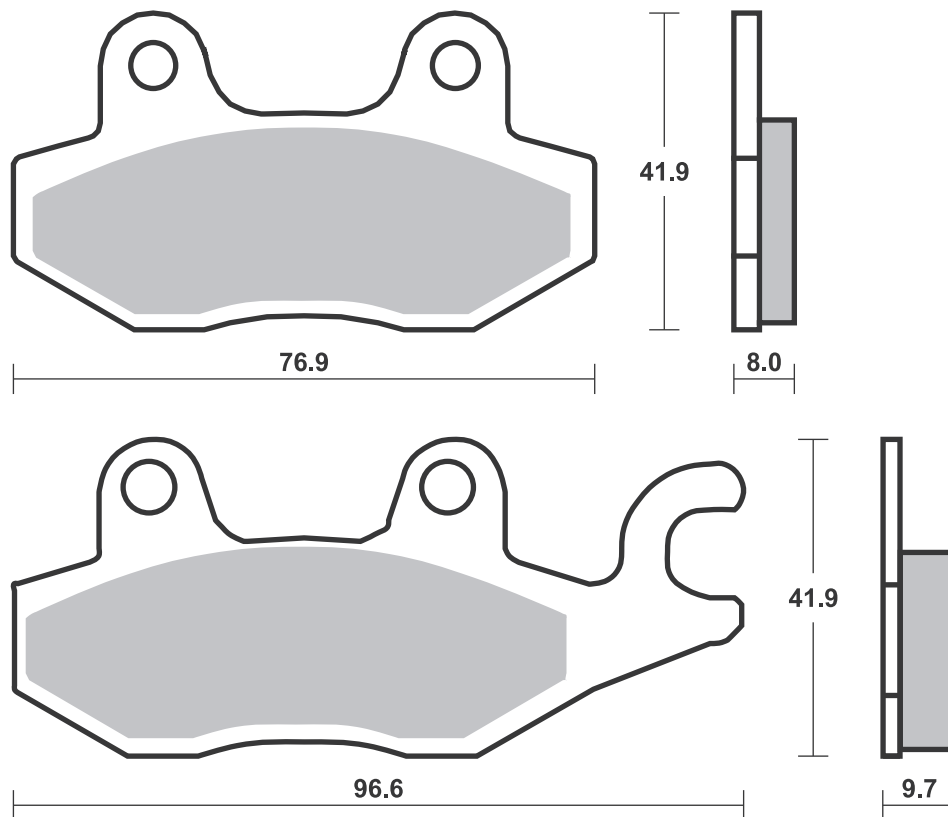



Available compounds

HF • HS • SP • DC • RST • DS-1 • DS-2

SBS 634

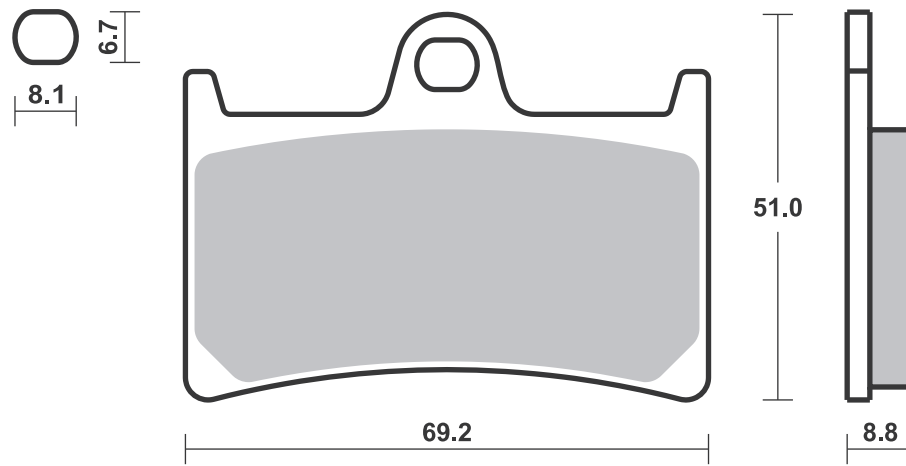

Available compounds

HF • LS

SBS 635

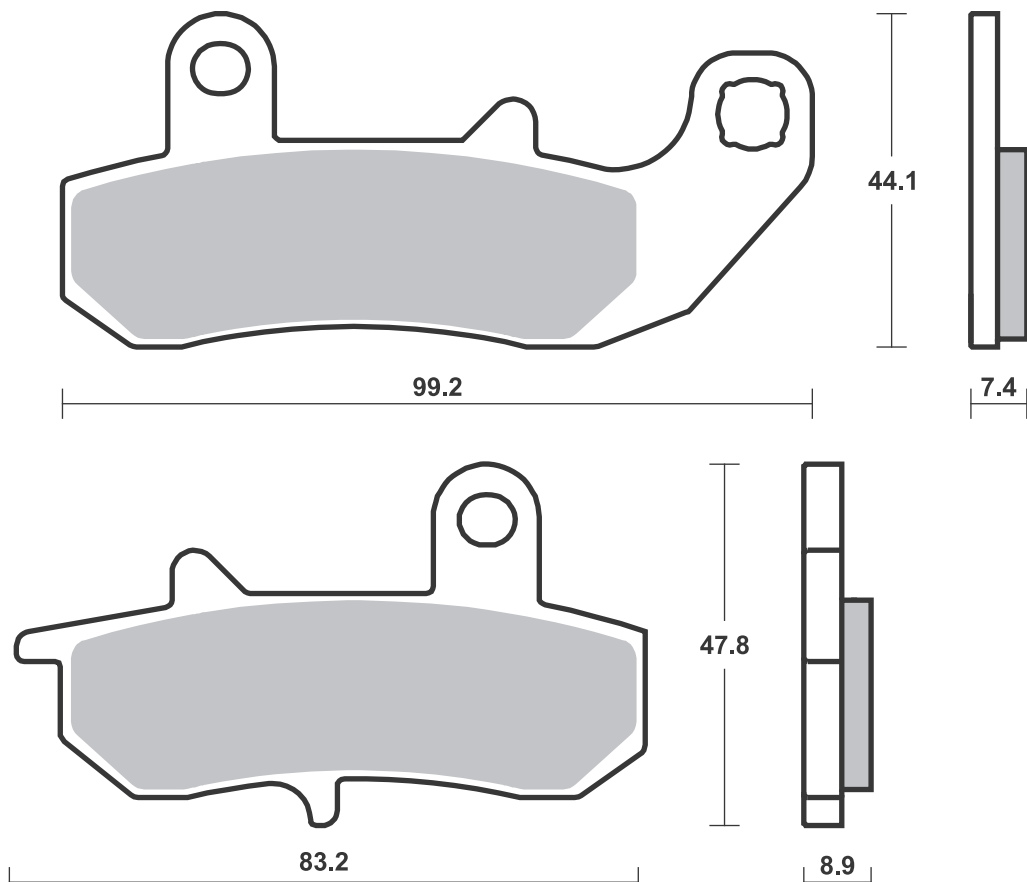





Available compounds

HF

SBS 636

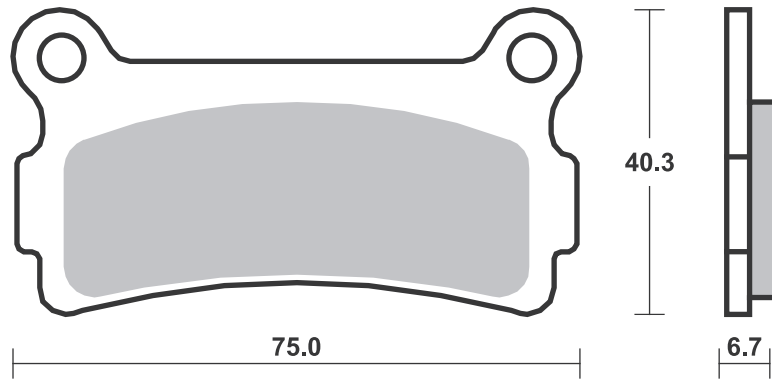

Available compounds

HF • SI • RSI

SBS 637

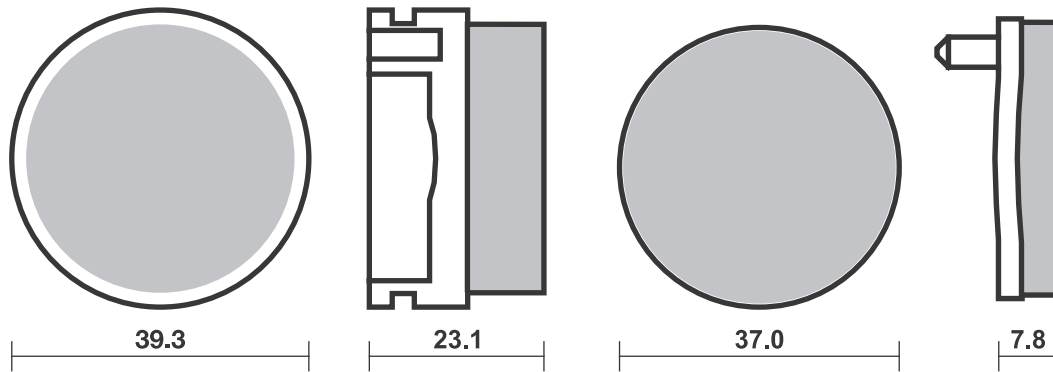



Available compounds

**HF • HS • LS • DC • RST • DS-1 • RQ • SI • RSI • PSI SBS 638**

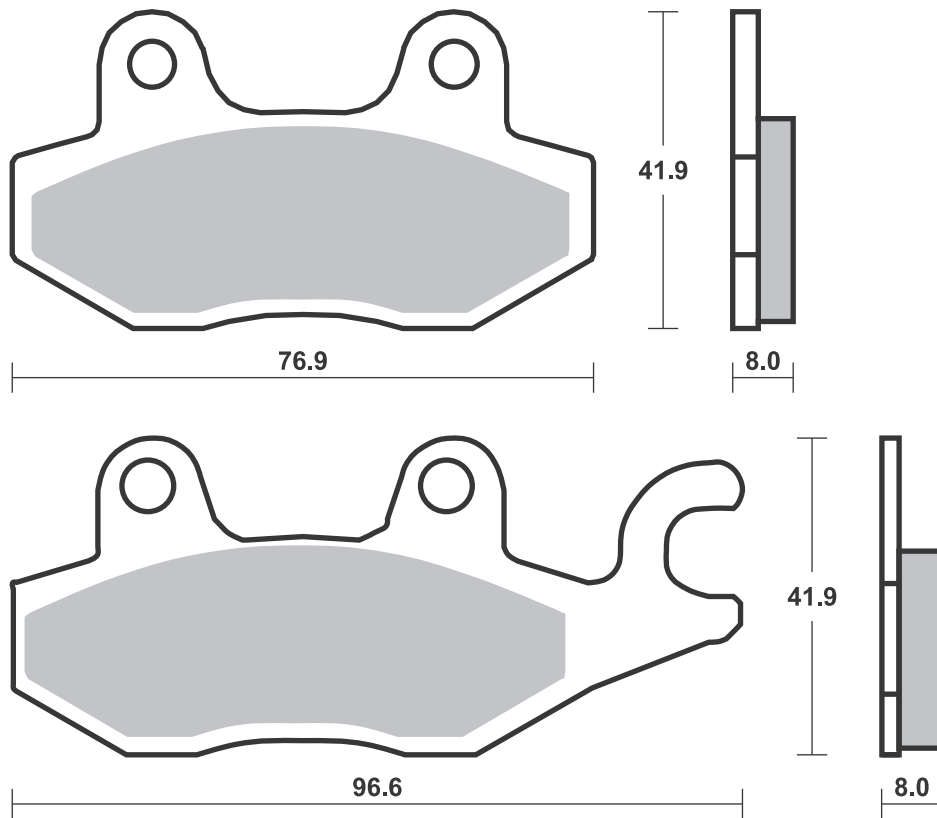

Available compounds

**HF • HS**

**SBS 640**

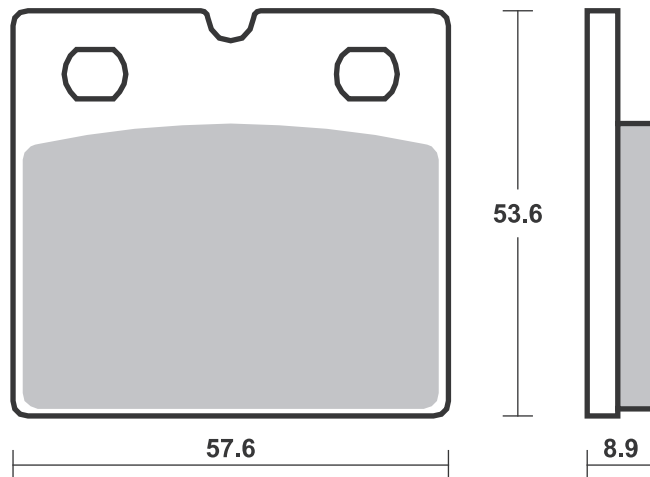



Available compounds

HF

SBS 641

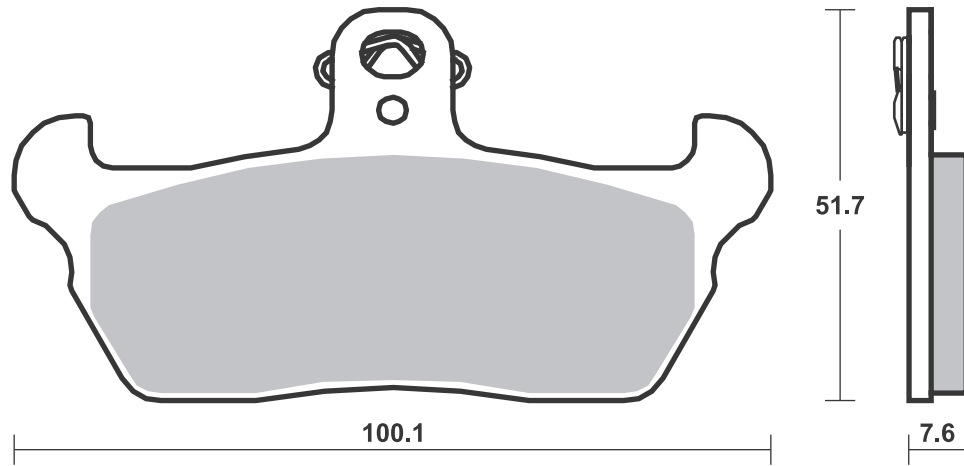

Available compounds

HF • SI • RSI • ATS • PSI

SBS 642

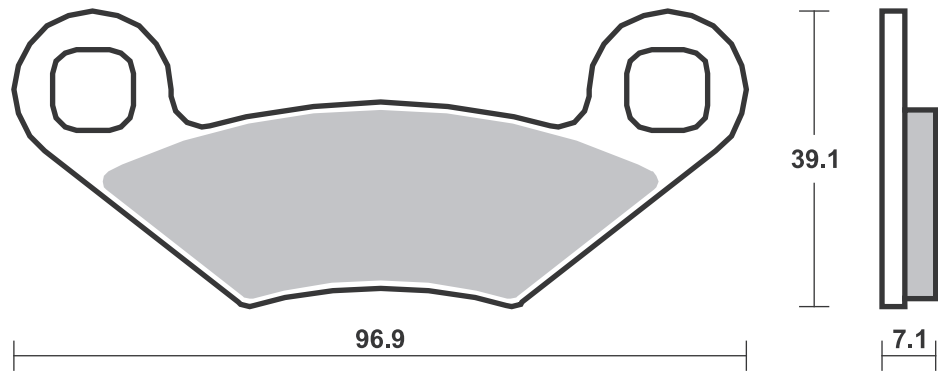

Available compounds

HF

SBS 643

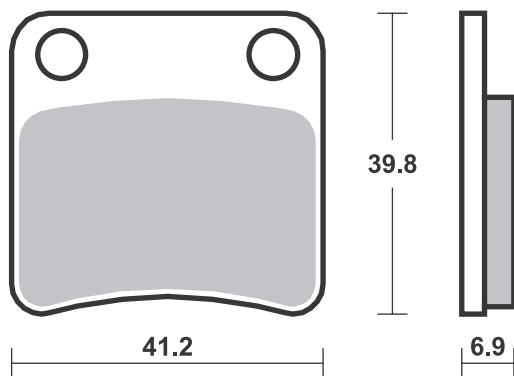

## Applications

### SBS 644 Recommended compound



<b>BMW</b>			
R80	800 R	91-95	<b>HS</b>
K1	1000	89-89	<b>HS</b>
K100	1000 LT	92-94	<b>HS</b>
K100	1000 RS	90-92	<b>HS</b>
R100	1000 R	91-95	<b>HS</b>
K1100	1100 LT/SE	92-00	<b>HS</b>
K1100	1100 RS	93-96	<b>HS</b>
R1100	1100 RS	93-93	<b>HS</b>

### SBS 645 Recommended compound



<b>YAMAHA</b>			
FZR	600 R	90-91	<b>HS</b>
YZF	600 R	94-96	<b>HS</b>
TDM	850	96-01	<b>HS</b>
FZR	1000 EX UP	90-91	<b>HS</b>
V-MAX	1200	93-03	<b>HS</b>

### SBS 647 Recommended compound



<b>CAGIVA</b>			
	900 Canyon I.E.	97-97	<b>HS</b>
<b>HONDA</b>			
VT	600 C, Shadow	88-93	<b>HS</b>
NX	650 Dominator J-K	88-92	<b>HS</b>
GL	1500 Gold Wing		
	Aspencade,		
	Interstate, SE	94-00	<b>HS</b>
GL	1500 Gold Wing,		
	Gold Wing SE	88-99	<b>HS</b>

Brake Pad 1:1 Drawings,  
Compounds, Fitments

Available compounds

HF • HS

SBS 644

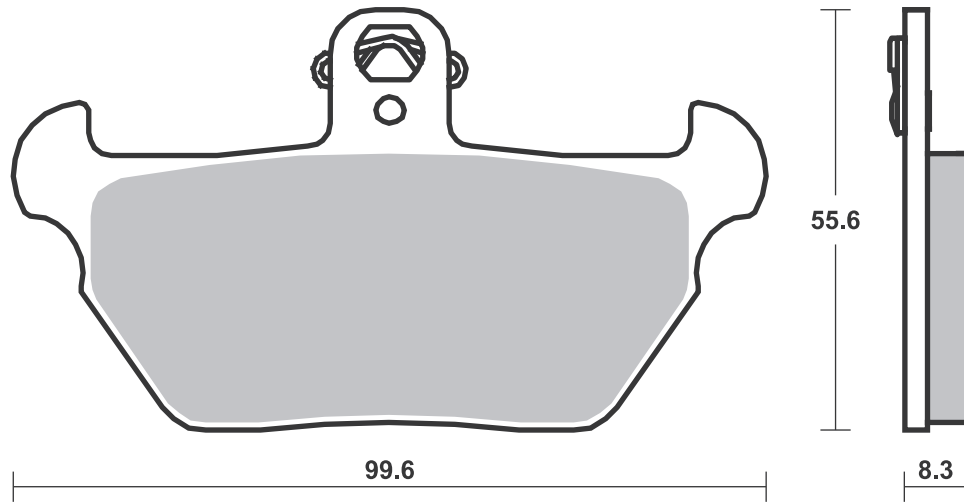

Available compounds

HF • HS • DCC

SBS 645

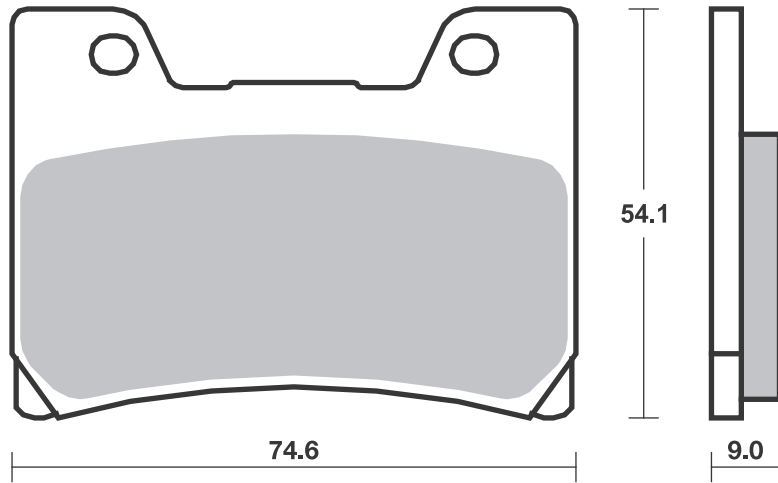

Available compounds

HF • HS

SBS 647

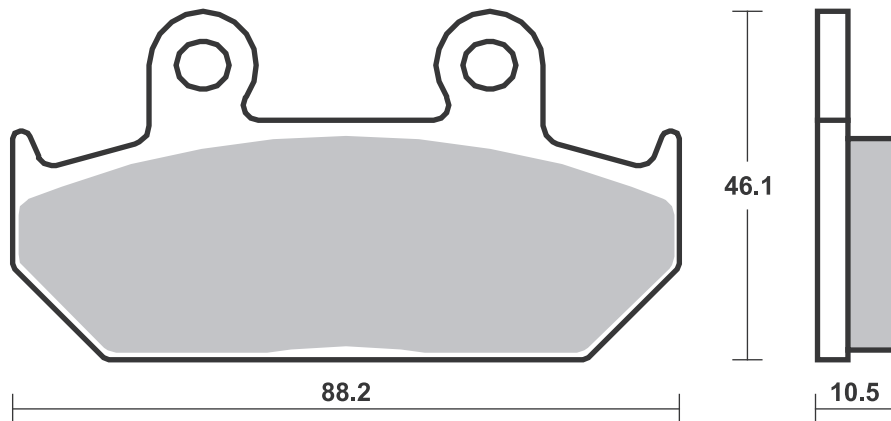

**SBS 648** Recommended compound



<b>SUZUKI</b>			
RM	125	91-95	<b>RSI</b>
DR-Z	250	01-07	<b>SI</b>
RM	250	91-95	<b>RSI</b>
RMX	250	89-98	<b>RSI</b>
DR	350	90-99	<b>HF</b>
DR	350 V, W, X	97-99	<b>SI</b>
DR	650 SE T-W	96-99	<b>HF</b>

<b>YAMAHA</b>			
YZ	125	96-97	<b>RSI</b>
YZ	250 B1-J1	91-97	<b>RSI</b>
WR	400 F	98-98	<b>SI</b>
YZ	400 F	98-98	<b>RSI</b>

**SBS 649** Recommended compound



<b>ARCTIC CAT</b>			
	400 DVX	04-08	<b>SI</b>

<b>HYOSUNG</b>			
TE	400	05-06	<b>SI</b>
TE	450	07-11	<b>SI</b>

<b>KAWASAKI</b>			
KFX	400	02-05	<b>SI</b>

<b>SUZUKI</b>			
LT	250	88-94	<b>SI</b>
LT-Z	400 Quad Sport	02-19	<b>SI</b>
LT-R	450	06-12	<b>SI</b>
LT	500	87-95	<b>SI</b>

Brake Pad 1:1 Drawings,  
Compounds, Fitments



Available compounds

HF • SI • RSI

SBS 648

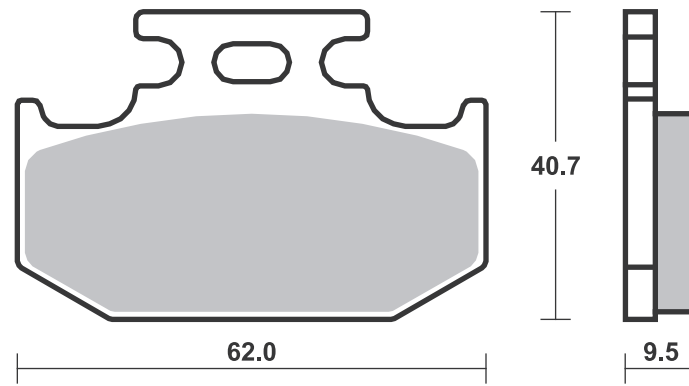

Available compounds

HF • SI • RSI

SBS 649

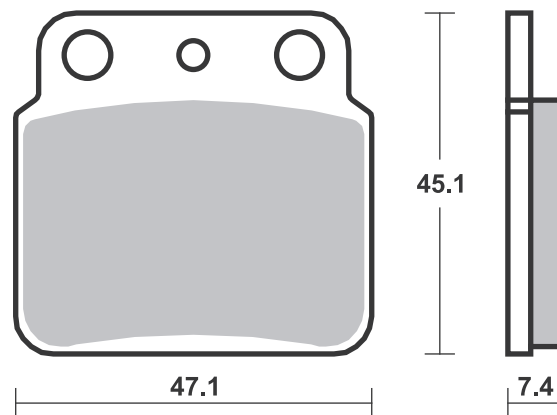

**SBS 651 Recommended compound**



<b>APRILIA</b>			
SX	125	08- 13	HF
	650 Pegaso	92- 94	HF

**SBS 652 Recommended compound**



<b>ITALJET</b>			
SM	125	02- 05	HF

Brake Pad 1:1 Drawings,  
Compounds, Fitments

Available compounds

HF

SBS 651

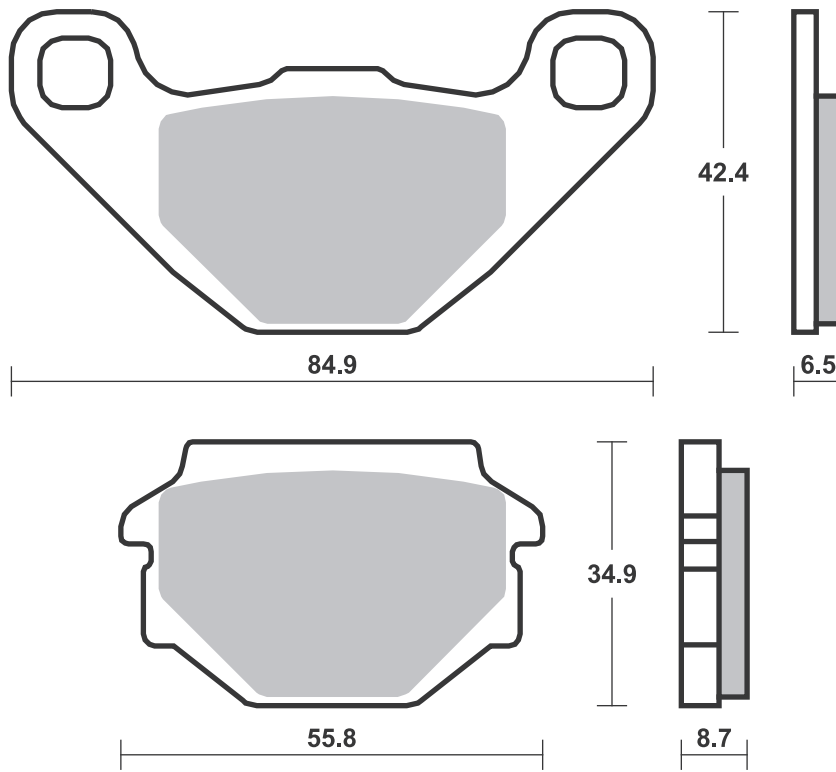

Available compounds

HF

SBS 652

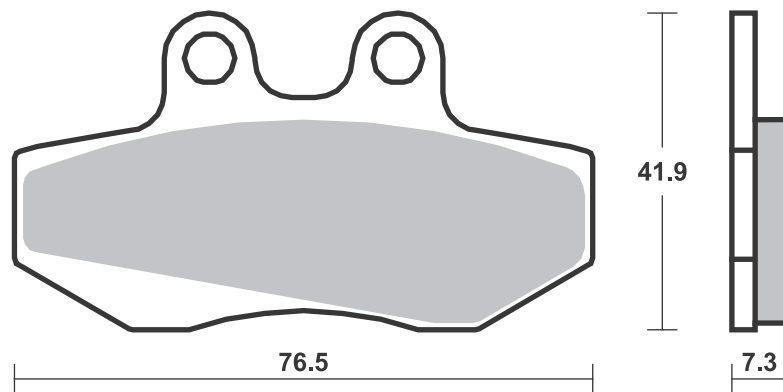

# Applications

## SBS 654 Recommended compound



HONDA			
VTR	250	98-02	HF
ST	1100 ABS-TCS	92-95	LS

## SBS 655 Recommended compound



ISR CALIPERS			
2 Piston (22-036)			
4 Piston (22-043)			
6 Piston Racing Caliper, small			

Brake Pad 1:1 Drawings, Compounds, Fitments

Available compounds

HF • HS • LS

SBS 654

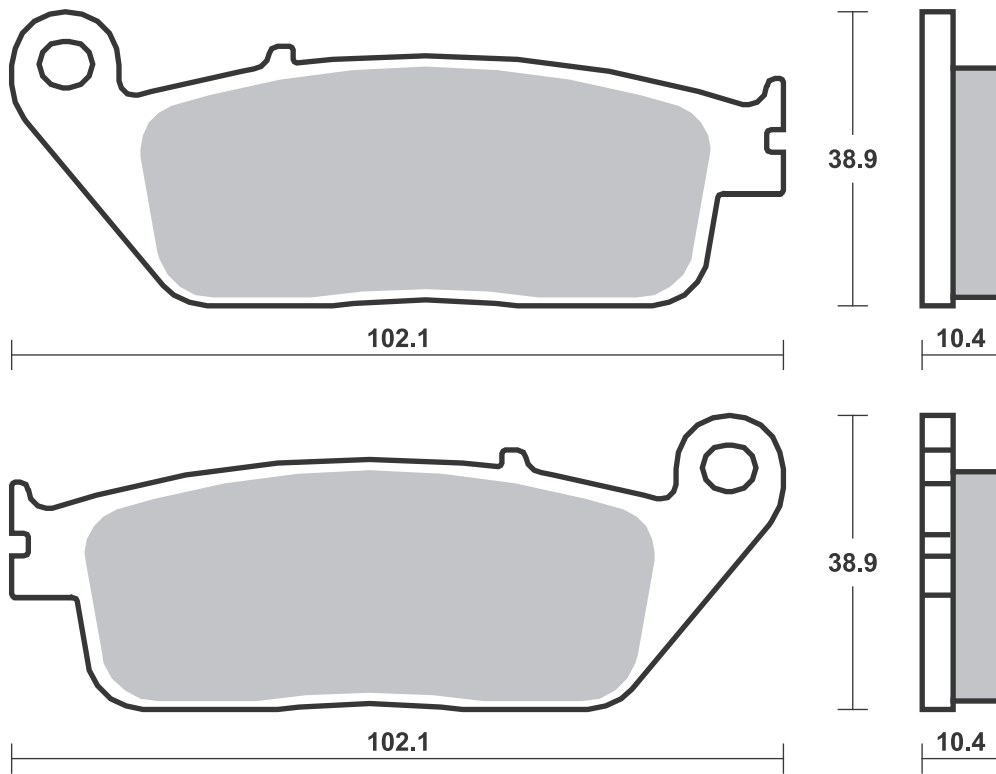

Available compounds

HF • DC

SBS 655

1 set = 6 pcs.

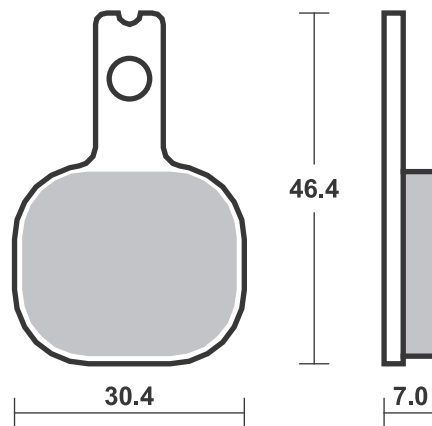

# Applications

## SBS 656 Recommended compound



### HARRISON/BILLET CALIPERS

Mini-6

### ISR CALIPERS

6 Piston Racing Caliper, large

## SBS 657 Recommended compound



### HONDA

CB	599	04-04	LS
CB	600 Hornet ABS	07-12	LS
CBR	600 F ABS	11-13	LS
CBR	600 F, Super Sport	91-94	LS
CBR	600 F3	95-98	LS
CBR	600 F4, F4 Sport	99-06	LS
CBR	600 RR	03-06	LS
FMX	650 Rally	05-08	LS
NT	650 V Deauville	01-01	LS
NC	700 D Integra	12-13	LS
NC	700 SA ABS	12-13	LS
NC	700 SD ABS	12-13	LS
NC	700 XA ABS	12-13	LS
NC	700 XD ABS	12-13	LS
CB	750 N, F, Seven Fifty	92-95	LS
CBR	900 RR Fireblade	92-03	LS
	919	02-02	LS
CBR	929 RR	00-01	LS
CBR	954 RR	02-03	LS
CB	1000 F (Big One)	93-97	LS
CBR	1000 RR Fireblade	04-05	LS
CRF	1000 L Africa Twin	16-19	LS
CRF	1000 L Africa Twin Adventure		
	Sports	18-19	LS
RVT	1000 RC51	00-06	LS
VTR	1000 SP-1, SP-2	00-06	LS
VTR	1000 Super Hawk	97-07	LS
CB	1100	13-13	LS
CB	1100, EX	14-19	LS
CB	1100 EX ABS	17-19	LS
CB	1100 RS ABS	17-19	LS
CRF	1100 L Africa Twin	20-21	LS
CRF	1100 L Africa Twin Adventure		
	Sports	20-21	LS
NT	1100	22-22	LS
VT	1100 C2 Shadow A.C.E.	95-04	LS
VT	1100 C2 Shadow Sabre	00-05	LS
VT	1100 C3 Shadow Aero	98-04	LS
VT	1100 T Shadow	98-04	LS

### HONDA

CB	1300	05-13	LS
CB	1300 S	11-15	LS
VT	1300 CX A Fury	10-18	LS
VT	1300 Interstate	11-15	LS
VT	1300 Sabre	11-13	LS
VT	1300 Stateline	11-16	LS
VTX	1300 C	04-09	LS
VTX	1300 S	03-07	LS

### KAWASAKI

ZX-25R	250	20-20	LS
EN	650 Vulcan S	15-19	LS
EN	650 Vulcan S Cafe	17-19	LS
EN	650 Vulcan S SE	17-18	LS
EX	650 Ninja KRT ABS	17-20	LS
EX	650 Ninja Performance		
	ABS	17-20	LS
EX	650 Ninja Tourer ABS	17-20	LS
KLE	650 Versys	16-21	LS
Z	650 ABS	17-19	LS
Z	750, ABS	07-12	LS
Z	900 RS	18-21	LS
Z	900 RS Cafe	18-21	LS
KLE	1000 Versys	12-18	LS
KLE	1000 Versys ABS	15-20	LS
KLE	1000 Versys LT	15-16	LS
KLE	1000 Versys SE	19-20	LS
KLV	1000	04-07	LS
Z	1000 H2	20-21	LS
Z	1000 H2 SE	21-21	LS

### SUZUKI

DL	250 V-Strom	17-19	HF
GW	250 Inazuma	12-19	LS
DL	650 V-Strom	04-20	LS
DL	650 V-Strom XT	15-20	LS
GSF	650 Bandit	07-11	LS
GSF	650 Bandit / S Bandit ABS	06-06	LS
GSF	650 Bandit ABS	07-12	LS
GSF	650 S Bandit	07-11	LS
GSF	650 S Bandit ABS	07-13	LS
GSX	650 F	08-18	HF

### SUZUKI

SV	650, S	03-12	LS
SV	650, S ABS	07-18	LS
GSR	750	11-16	LS
GSX-S	750	15-19	LS
GSX-S	750 Z	15-16	LS
GSX-S	950	22-22	LS
DL	1000 V-Strom	02-13	LS
GSX-S	1000	15-19	LS
GSX-S	1000 F	15-19	LS
GSX-S	1000 Katana	19-21	LS
SV	1000, S	03-07	LS
GSF	1200 Bandit	06-06	LS
GSF	1200 S Bandit	06-06	LS
GSF	1250 A Bandit	07-18	LS
GSF	1250 Bandit	06-18	LS
GSF	1250 F Bandit	12-18	LS
GSF	1250 S Bandit	06-18	LS
GSF	1250 SA Bandit	07-18	LS
GSX	1250 FA Bandit	16-18	LS
GSX	1250 FA Traveller	15-16	LS
	1300 B-King	07-07	LS

### YAMAHA

FZ6	600	04-08	LS
FZ6	600 Fazer	04-08	LS
FZ6	600 Fazer S2	07-09	LS
FZ6	600 Fazer S2 ABS	07-09	LS
FZ6	600 S2	07-09	LS
FZ6	600 S2 ABS	07-09	LS
YZF	600 R6	03-16	LS
FZ-07	700	14-17	LS
MT-07	700	14-18	LS
MT-07	700 Moto Cage	15-17	LS
MT-07	700 SP	18-18	LS
MT-07	700 Tracer	16-20	LS
MT-07	700 Tracer GT	19-19	LS
XSR	700	16-20	LS
XSR	700 XTrIBUTE	19-20	LS
YZF	700 R7	22-22	LS
	800 Fazer 8	10-15	LS
FZ8	800	10-14	LS
FJ-09	850	15-17	LS
FZ-09	850	14-17	LS
MT-09	850	18-18	LS
MT-09	900	14-20	LS

Available compounds

HF • DC • RQ • H.HF

SBS 656

1 set = 6 pcs.

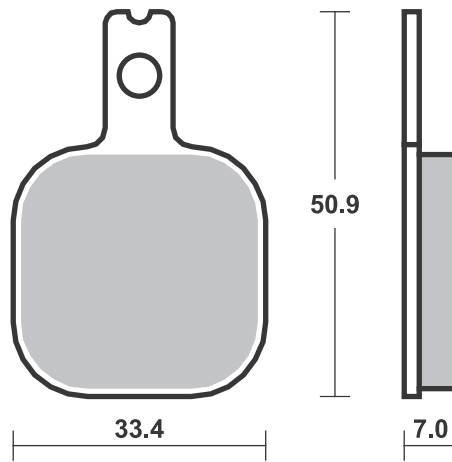

Available compounds

HF • LS • RQ

SBS 657

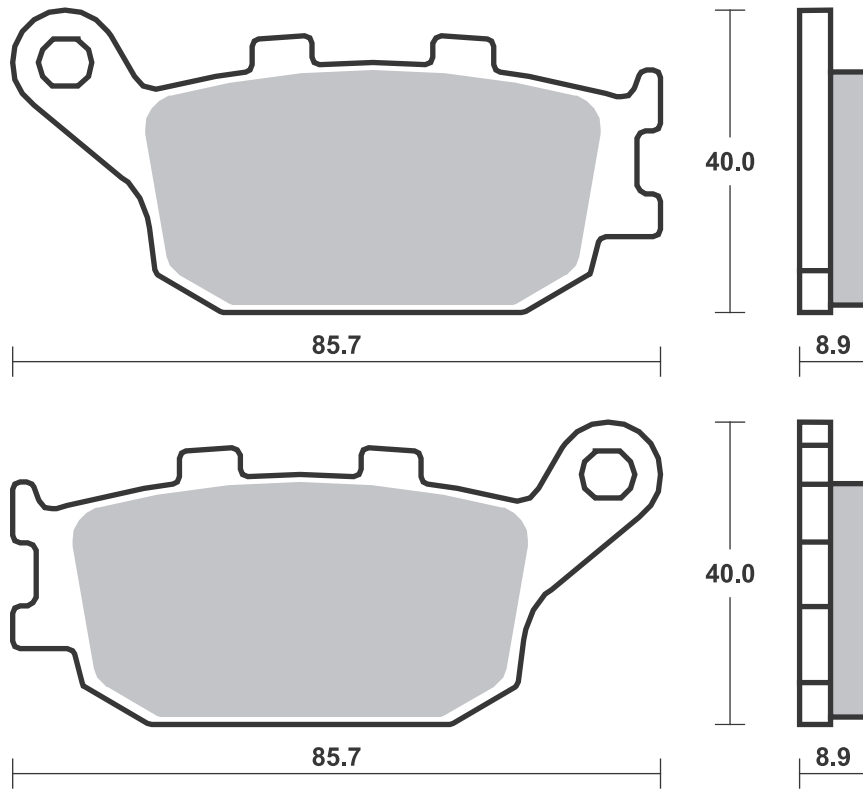

# Applications

## SBS 657 Recommended compound



### YAMAHA

MT-09	900 SP	18-20	<b>LS</b>
MT-09	900 Sport Tracker	15-16	<b>LS</b>
MT-09	900 Street Rally	14-16	<b>LS</b>
MT-09	900 Tracer	15-20	<b>LS</b>
MT-09	900 Tracer GT	18-20	<b>LS</b>
XSR	900	16-22	<b>LS</b>
XSR	900 Abarth	17-18	<b>LS</b>
FZ1	1000 Fazer	06-16	<b>LS</b>
FZ-10	1000	16-17	<b>LS</b>
MT-10	1000	16-22	<b>LS</b>
MT-10	1000 SP	17-19	<b>LS</b>
YZF	1000 R1	04-06	<b>LS</b>
YZF	1000 R1 (4-pad)	07-14	<b>LS</b>
YZF	1000 R1 (4-pad)		
	ABS	12-14	<b>LS</b>
YZF	1000 R1 LE	06-06	<b>LS</b>

## SBS 658 Recommended compound



### BUELL

	all models	94-97	<b>HF</b>
RS	1200	12-12	<b>HF</b>

### PERFORMANCE MACHINE

	125 X 6		
	137 X 6		

Brake Pad 1:1 Drawings, Compounds, Fitments



Available compounds

HF • LS • RQ

SBS 657

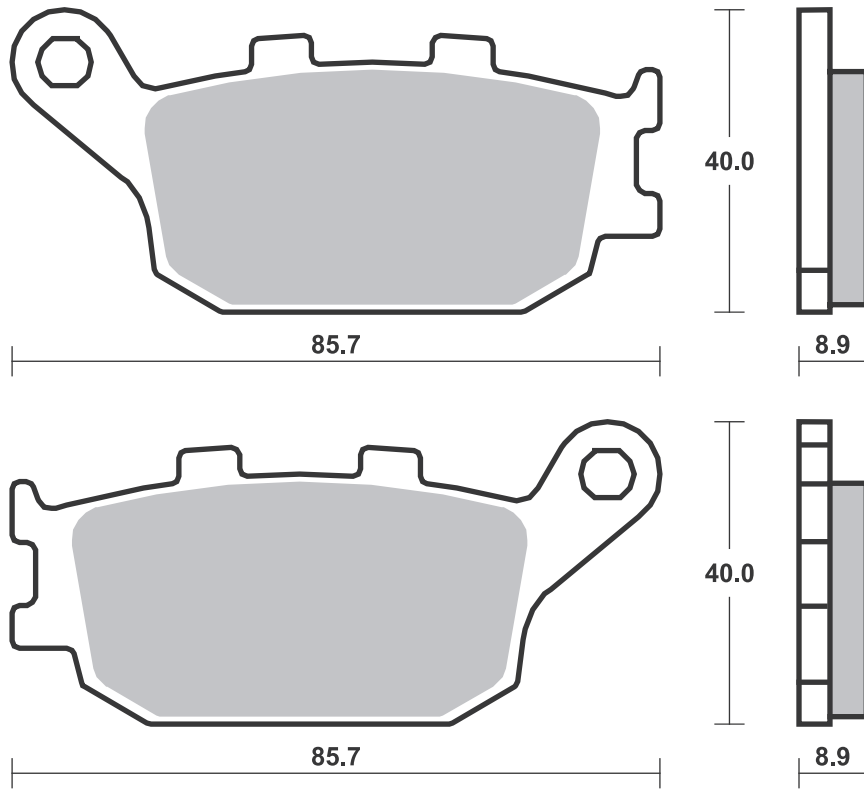

Available compounds

HF • RQ • H.HF • H.CT

SBS 658

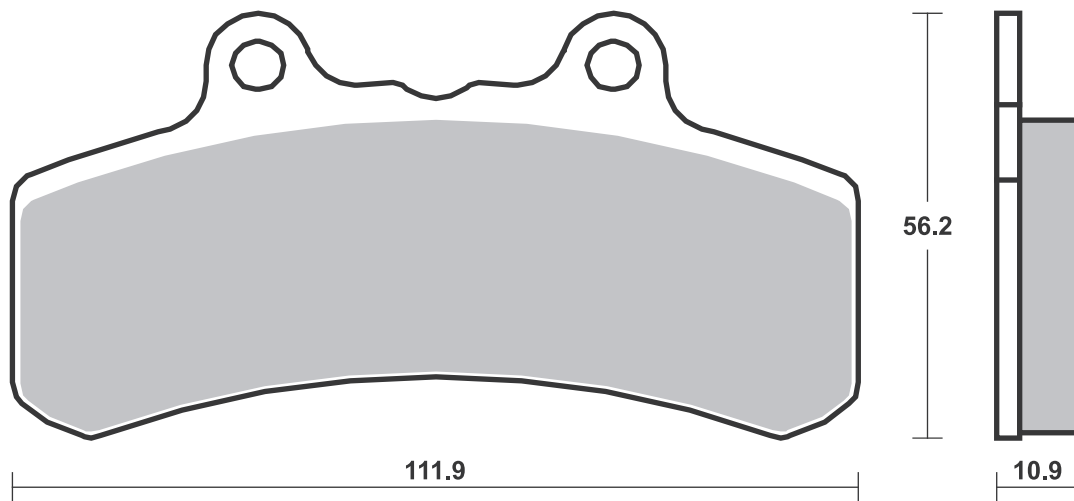



Available compounds

HF • RQ

SBS 659

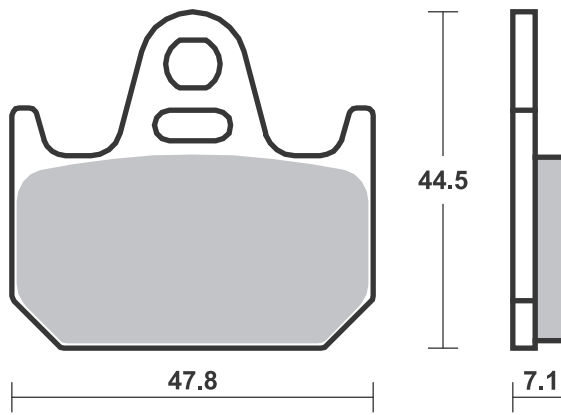

Available compounds

RQ

SBS 660

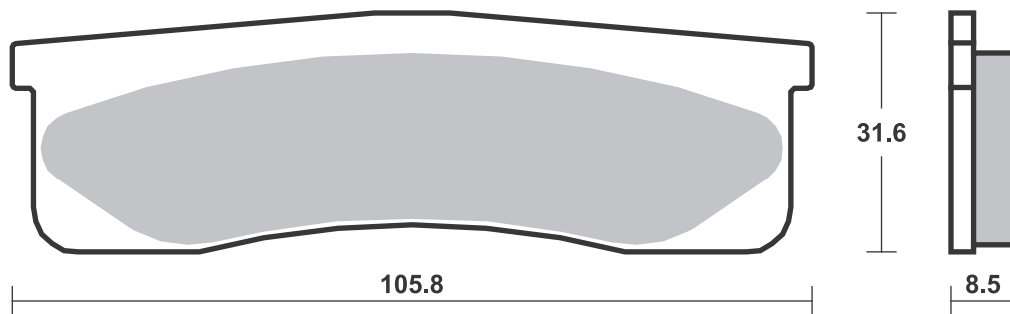

Available compounds

RQ

SBS 661

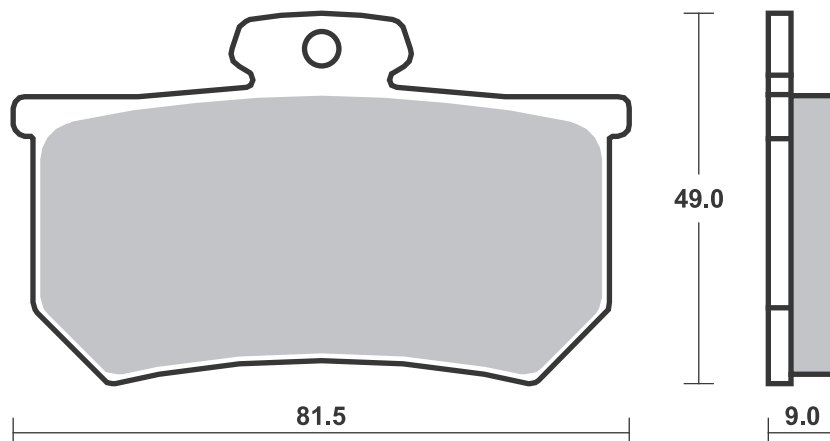



Available compounds

HF • RQ • H.HF • H.CT

SBS 662

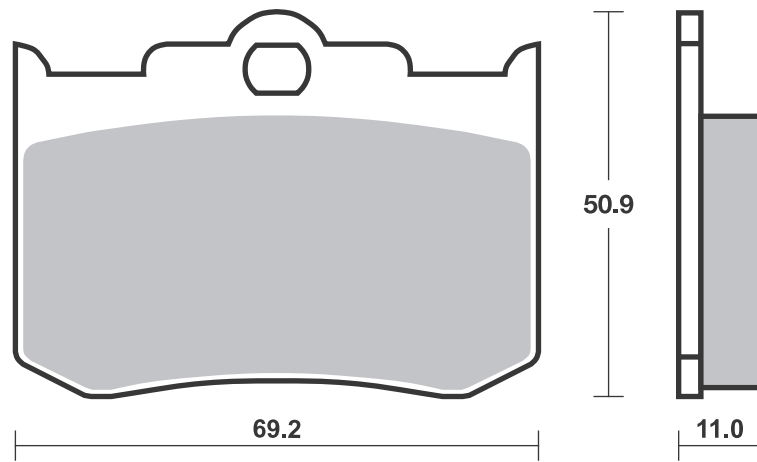

Available compounds

HF • HS

SBS 663

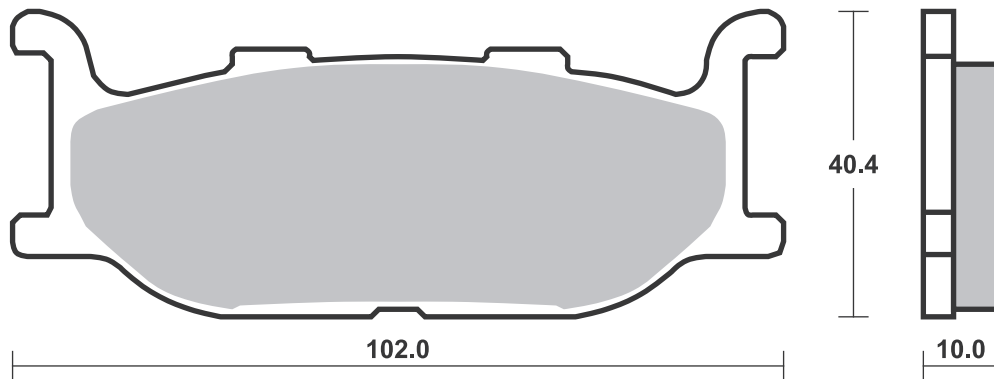

Available compounds

HF • HS

SBS 665

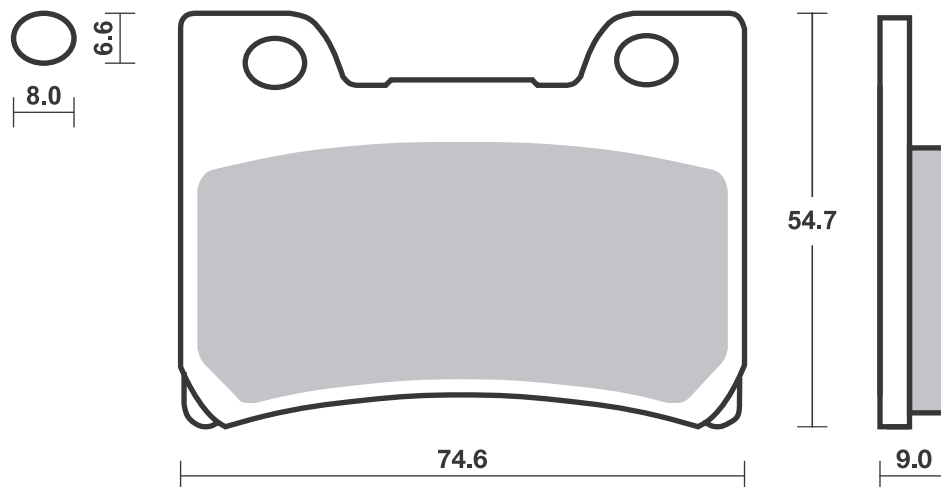



Available compounds

**HF**

**SBS 667**

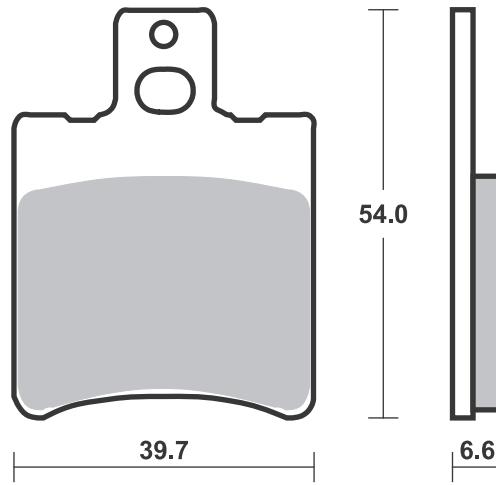

Available compounds

**H.HF • H.CT • H.LS**

**SBS 668**

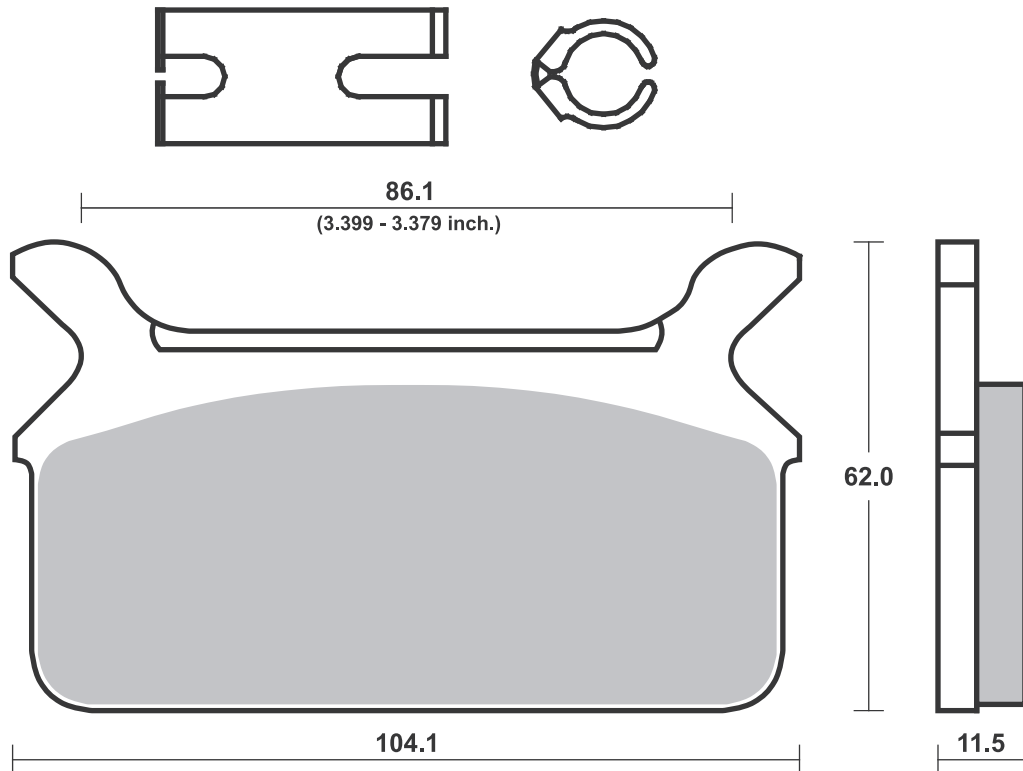

**SBS 669** Recommended compound

<b>HARLEY DAVIDSON</b>			
XLH	Series	88-99	<b>H.LS</b>
XLH	883 Sportster	87-99	<b>H.HF</b>
XLH	1100	87-88	<b>H.LS</b>
XLH	1200 Sportster	90-99	<b>H.LS</b>
FLHT	1340 Electra		
	Glide		
	Classic	87-99	<b>H.LS</b>
FLSTC	1340 Heritage		
	Softail Cl.	90-99	<b>H.LS</b>
FLSTF	1340 Fat Boy	90-99	<b>H.LS</b>
FLSTN	1340 Heritage		
	Softail Nost.	93-99	<b>H.LS</b>
FXDB	1340 Dyna Glide		
	Daytona	91-99	<b>H.LS</b>
FXDB	1340 Dyna Glide		
	Sturgis	91-99	<b>H.HF</b>
FXDB	1340 Sturgis	91-99	<b>H.LS</b>
FXDL	1340 Dyna Low		
	Rider	93-99	<b>H.LS</b>
FXDWG	1340 Dyna Wide		
	Glide	93-99	<b>H.LS</b>
FXE	1340	82-82	<b>H.HF</b>
FXLR	1340 Low Rider		
	Custom	87-99	<b>H.LS</b>
FXR	1340	87-88	<b>H.LS</b>
FXR	1340 Super Glide	90-99	<b>H.LS</b>
FXRS	1340 Low Rider		
	Sport	87-99	<b>H.LS</b>
FXRS	1340 Low Rider		
	Sport Ed.	90-99	<b>H.LS</b>



<b>HARLEY DAVIDSON</b>			
FXRS	1340 Low Rider,		
	Convert.	90-99	<b>H.LS</b>
FXRT	1340 Sport Glide	90-99	<b>H.LS</b>
FXSTC	1340 Softail Custom	88-99	<b>H.LS</b>
FXSTS	1340 Springer		
	Softail	90-99	<b>H.LS</b>
FXWG	1340	87-88	<b>H.LS</b>

**SBS 671** Recommended compound

<b>APRILIA</b>			
SX	125	08-13	<b>HF</b>
RST	1000 Futura	01-03	<b>LS</b>
<b>BENELLI</b>			
BX	449 Cross	07-09	<b>RSI</b>
BX	505 Enduro	08-08	<b>SI</b>
<b>BIMOTA</b>			
DBX	1100	13-18	<b>LS</b>
<b>BMW</b>			
G	450 X	08-10	<b>SI</b>
	1200 HP2 Enduro	04-06	<b>LS</b>
	1200 HP2 Sport	08-10	<b>LS</b>
K	1200 GT (K44)		
	With Integral		
	ABS	04-08	<b>LS</b>
R	1200 Nine-T	14-22	<b>LS</b>
R	1200 Nine-T Pure	17-22	<b>LS</b>
R	1200 Nine-T Racer	17-20	<b>LS</b>
R	1200 Nine-T		
	Scrambler	16-22	<b>LS</b>
R	1200 Nine-T		
	Urban GS	17-22	<b>LS</b>
K	1300 GT	09-10	<b>LS</b>
<b>BREMBO RACING CALIPERS</b>			
Floating Motocross			
Caliper 22.5930.62			



<b>BREMBO RACING CALIPERS</b>			
Off Road 122A99021, P2 24			
Off Road XQ21361, P2 28			
<b>CAGIVA</b>			
	900 Elefant	93-97	<b>HF HF</b>
<b>CCM</b>			
	450 MX	08-10	<b>RSI</b>
GP	450	16-16	<b>SI</b>
604	600 RS	01-01	<b>HF</b>
604E	600 Sport	99-01	<b>SI</b>
604E	600 Supermoto	99-01	<b>SI</b>
C25	600	96-98	<b>SI</b>
	644 DS	03-06	<b>HF</b>
	644 R30	02-06	<b>HF</b>
<b>CF MOTO</b>			
	700 CL-X	22-22	<b>LS</b>
	800 MT Sport	22-22	<b>LS</b>
	800 MT Touring	22-22	<b>LS</b>
<b>DUCATI</b>			
	620 Multistrada	05-06	<b>HS</b>
	695 Monster	07-12	<b>HS</b>
	803 Monster S2R	05-07	<b>HS</b>
	803 Monster S2R		
	ABS	05-07	<b>HS</b>
	950 Multistrada	17-22	<b>LS</b>
	950 Multistrada S	19-22	<b>LS</b>



<b>DUCATI</b>			
	1158 Multistrada V4	21-21	<b>LS</b>
	1158 Multistrada V4		
	Pikes Peak	22-22	<b>LS</b>
	1158 Multistrada		
	V4S	21-22	<b>LS</b>
	1158 Multistrada		
	V4S Sport	21-22	<b>LS</b>
	1200 Multistrada	15-16	<b>LS</b>
	1200 Multistrada		
	Enduro	16-18	<b>LS</b>
	1200 Multistrada		
	Enduro Pro	18-18	<b>LS</b>
	1200 Multistrada S	15-17	<b>LS</b>
	1200 Multistrada S		
	D-air	15-17	<b>LS</b>
	1200 Multistrada S		
	Pikes Peak	16-17	<b>LS</b>
	1260 Multistrada	18-18	<b>LS</b>
	1260 Multistrada		
	Enduro	19-21	<b>LS</b>
	1260 Multistrada S	18-19	<b>LS</b>
	1260 Multistrada S		
	D-air	18-19	<b>LS</b>
	1260 Multistrada S		
	Grand Tour	20-20	<b>LS</b>
	1260 Multistrada S		
	Pikes Peak	18-19	<b>LS</b>



Available compounds

H.HF • H.CT • H.LS

SBS 669

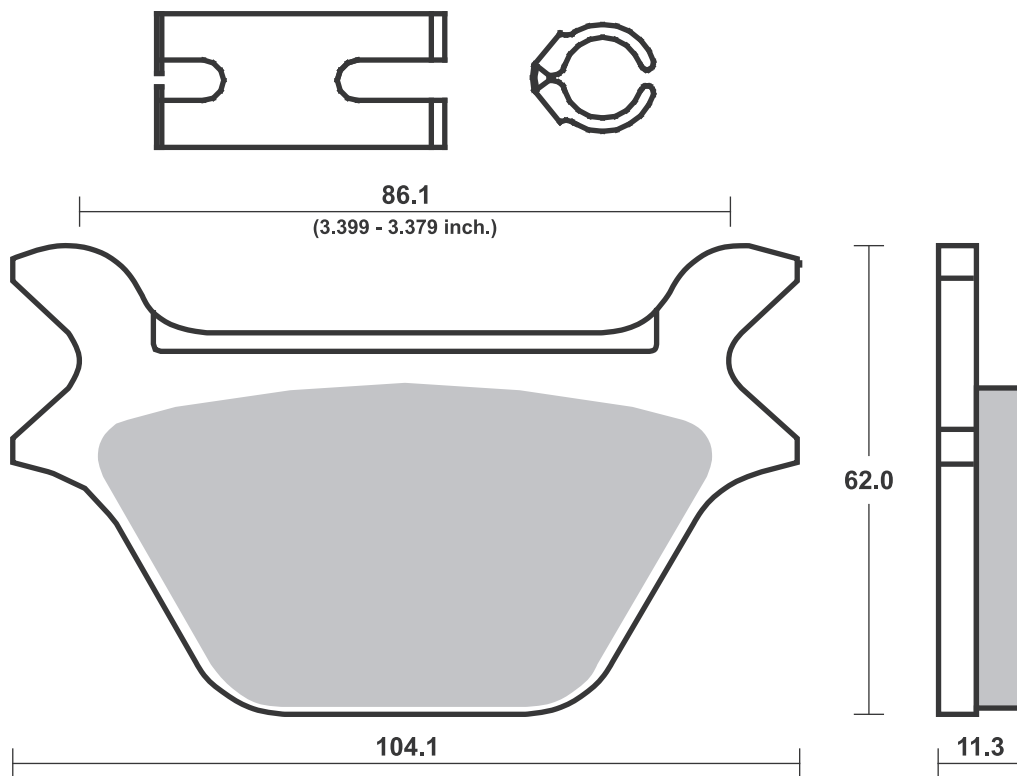

Available compounds

HF • HS • LS • RQ • CS • SI • RSI • H.HF • H.CT • H.LS SBS 671

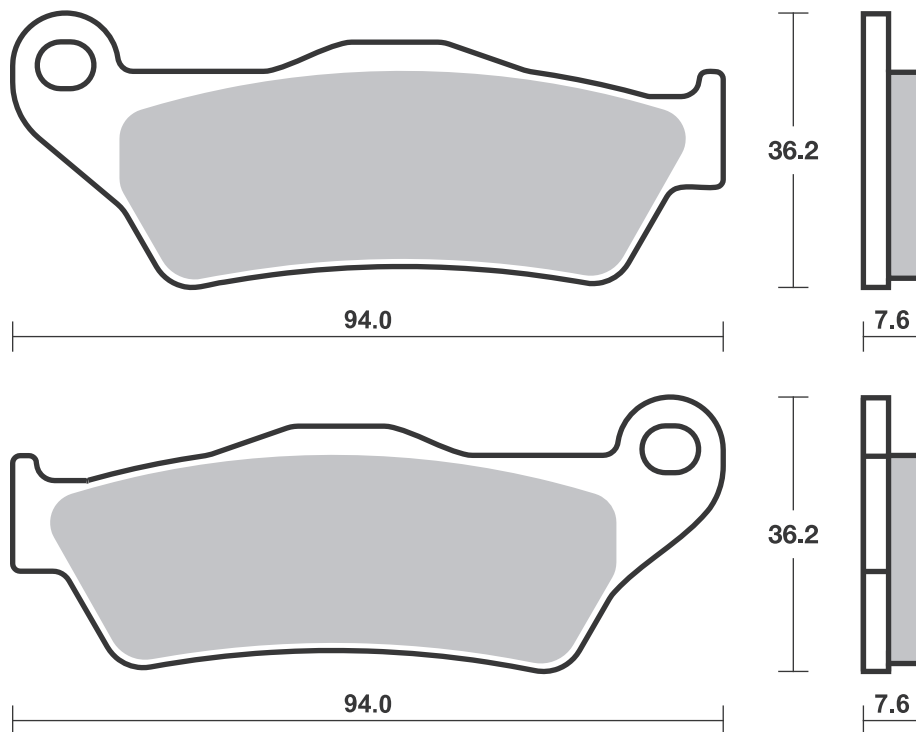



<b>GAS GAS</b>			
	50 Wild HP	04-07	<b>SI</b>
MC	85	21-22	<b>RSI</b>
EC	125	97-99	<b>SI</b>
MC	125	21-22	<b>RSI</b>
	200 Wild HP	08-09	<b>SI</b>
EC	200	99-99	<b>SI</b>
EC	200 Ranger Enduro	19-19	<b>SI</b>
	240 Wild HP	04-06	<b>SI</b>
	250 Wild HP	08-08	<b>SI</b>
EC	250	97-99	<b>SI</b>
EC	250	21-22	<b>SI</b>
EC	250 F	21-22	<b>SI</b>
MC	250	97-99	<b>RSI</b>
MC	250	21-22	<b>RSI</b>
MC	250 F	21-22	<b>RSI</b>
	300 Wild HP	03-05	<b>SI</b>
EC	300	99-99	<b>SI</b>
EC	300	21-22	<b>SI</b>
EC	300 Ranger Enduro	19-19	<b>SI</b>
EC	350 F	21-22	<b>SI</b>
MC	350 F	22-22	<b>RSI</b>
	450 Wild HP	03-09	<b>SI</b>
MC	450 F	21-22	<b>RSI</b>
	515 Wild HP	09-09	<b>SI</b>

**HARLEY DAVIDSON**

XG	500 Street	16-18	<b>H.HF</b>
XG	750 Street	16-17	<b>H.HF</b>
XG	750 Street Rod	18-20	<b>H.HF</b>

**HIGHLAND**

	450 MX	06-09	<b>RSI</b>
	950 V2 Motard	00-08	<b>HF</b>
	950 V2 Outback	99-08	<b>HF</b>

**HUSABERG**

	all models	93-98	<b>SI</b>
TE	125	13-13	<b>SI</b>
FE	250	13-13	<b>SI</b>
TE	250	11-13	<b>SI</b>
TE	300	11-13	<b>SI</b>
FE	350	13-13	<b>SI</b>
FE	390	10-13	<b>SI</b>
FC	400	99-02	<b>RSI</b>
FE	400 ,S,E	99-03	<b>SI</b>
FC	450	03-08	<b>RSI</b>
FE	450	09-13	<b>SI</b>
FE	450 e	04-08	<b>SI</b>
FX	450 e	03-08	<b>RSI</b>
FC	470 , e	01-02	<b>RSI</b>
FX	470 e	01-02	<b>RSI</b>
FC	501	99-01	<b>RSI</b>
FE	501	13-13	<b>SI</b>
FE	501 ,S,E	99-04	<b>SI</b>
FC	550	01-05	<b>RSI</b>
FE	550 e	04-08	<b>SI</b>
FE	570	09-13	<b>SI</b>
FC	600	99-01	<b>RSI</b>
FE	600 ,S,E	99-02	<b>SI</b>
FE	650 e	01-08	<b>SI</b>
FX	650 e	01-05	<b>RSI</b>

**HUSQVARNA**

TC	85	21-22	<b>RSI</b>
CR	125	96-13	<b>RSI</b>
SM	125 S	09-13	<b>HF</b>
SM	125 S 4T	11-13	<b>HF</b>

**HUSQVARNA**

SM	125 Supermotard,		
	S	99-13	<b>HF</b>
TC	125	14-22	<b>RSI</b>
TE	125	14-16	<b>SI</b>
TE	125 4T	11-13	<b>HF</b>
TX	125	17-19	<b>SI</b>
WR	125	96-13	<b>SI</b>
WRE	125	96-13	<b>SI</b>
TE	150 i	20-22	<b>SI</b>
CR	250	96-05	<b>RSI</b>
FC	250	14-22	<b>RSI</b>
FE	250	14-22	<b>SI</b>
TC	250	02-22	<b>RSI</b>
TE	250	02-18	<b>SI</b>
TE	250 4T	10-13	<b>SI</b>
TE	250 i	20-22	<b>SI</b>
WR	250	96-13	<b>SI</b>
TC	300	14-15	<b>RSI</b>
TE	300	14-19	<b>SI</b>
TE	300 i	18-22	<b>SI</b>
WR	300	09-13	<b>SI</b>
TE	310 4T	10-13	<b>SI</b>
FC	350	14-22	<b>RSI</b>
FE	350	14-22	<b>SI</b>
TE	350	96-13	<b>SI</b>
WR	360	98-13	<b>SI</b>
TE	400	01-13	<b>SI</b>
TE	410	96-13	<b>SI</b>
TC	449	11-13	<b>RSI</b>
TE	449	11-13	<b>SI</b>
FC	450	14-22	<b>RSI</b>
FE	450	14-22	<b>SI</b>
TC	450	02-10	<b>RSI</b>
TE	450	02-10	<b>SI</b>
TE	450	14-14	<b>SI</b>
FE	501	14-22	<b>SI</b>
TC	510	02-10	<b>RSI</b>
TE	510	02-10	<b>SI</b>
TE	510 Centennial	04-05	<b>SI</b>
TE	511	11-14	<b>SI</b>
TC	570	01-13	<b>RSI</b>
TE	570	01-13	<b>SI</b>
TC	610	96-13	<b>RSI</b>
TE	610 Rallye	96-13	<b>RSI</b>
TE	630	10-13	<b>HS</b>
TE	630	14-14	<b>SI</b>
	901 Norden	22-22	<b>LS</b>

**KTM**

SX	85	21-22	<b>RSI</b>
SX	85 (19"/		
	16" wheels)	21-22	<b>RSI</b>
	125 SuperMoto	00-03	<b>HF</b>
EXC	125 Enduro	99-15	<b>SI</b>
EXE	125	00-00	<b>HF</b>
GS	125	92-97	<b>SI</b>
LC2	125	99-99	<b>HF</b>
MX	125	92-93	<b>SI</b>
SX	125	96-22	<b>RSI</b>
XC	125	19-22	<b>RSI</b>
SX	144	07-08	<b>RSI</b>
EXC	150 TPI	20-22	<b>SI</b>
SX	150	09-22	<b>RSI</b>
XC	150	10-19	<b>RSI</b>
XC	150 TPI	20-22	<b>RSI</b>
EXC	200 Enduro	99-16	<b>SI</b>
SX	200	03-04	<b>RSI</b>

**KTM**

XC	200	06-09	<b>RSI</b>
XC-W	200	06-16	<b>RSI</b>
EXC	250 Enduro	99-08	<b>SI</b>
EXC	250 Enduro 4T	99-06	<b>SI</b>
EXC	250 TPI	18-22	<b>SI</b>
EXC-F	250	07-22	<b>SI</b>
MX	250	92-93	<b>SI</b>
SX	250	96-22	<b>RSI</b>
SX-F	250	06-22	<b>RSI</b>
XC	250	06-14	<b>RSI</b>
XC	250 TPI	19-22	<b>RSI</b>
XC-F	250	10-22	<b>RSI</b>
XC-W	250	08-17	<b>RSI</b>
EXC	300	93-96	<b>SI</b>
EXC	300 Enduro	99-08	<b>SI</b>
EXC	300 TPI	18-22	<b>SI</b>
MX	300	92-92	<b>SI</b>
XC	300	06-14	<b>RSI</b>
XC	300 TPI	19-22	<b>RSI</b>
XC-W	300	06-08	<b>RSI</b>
EXC-F	350	11-22	<b>SI</b>
SX-F	350	11-22	<b>RSI</b>
XC-F	350	12-22	<b>RSI</b>
XCF-W	350	13-17	<b>RSI</b>
MX	360	96-97	<b>SI</b>
SX	360	96-97	<b>RSI</b>
XC	360	96-97	<b>SI</b>
EXC	380 Enduro	99-99	<b>SI</b>
MX	380	98-98	<b>SI</b>
SX	380	98-02	<b>RSI</b>
XC	380	98-03	<b>SI</b>
EXC	400 Racing	00-07	<b>SI</b>
LC4	400	93-02	<b>SI</b>
LC4-E	400 Enduro	99-02	<b>SI</b>
SC	400	99-00	<b>SI</b>
SX	400 Racing	00-02	<b>RSI</b>
SXC	400 Tiainen		
	Replica	99-00	<b>SI</b>
XC-W	400	07-10	<b>RSI</b>
EXC-F	450	04-22	<b>SI</b>
SX-F	450	03-22	<b>RSI</b>
XC-F	450	06-22	<b>RSI</b>
XCF-W	450	07-15	<b>RSI</b>
EXC-F	500	12-22	<b>SI</b>
MX	500	92-93	<b>SI</b>
XCF-W	500	12-17	<b>RSI</b>
SX	505 Racing	07-09	<b>RSI</b>
XC-F	505	08-09	<b>RSI</b>
EXC	520 Racing	00-02	<b>SI</b>
SX-F	520 Racing	00-02	<b>RSI</b>
EXC	525 Racing	03-06	<b>SI</b>
SX-F	525 Racing	03-06	<b>RSI</b>
XC-F	525	07-07	<b>RSI</b>
XCF-W	525	07-07	<b>RSI</b>
EXC	530 Racing	08-11	<b>SI</b>
XCF-W	530	09-11	<b>RSI</b>
SXC	540 Tiainen		
	Replica	99-00	<b>SI</b>
LC4	600 Six Days	92-92	<b>SI</b>
LC4	620 Competition	99-02	<b>SI</b>
LC4	620 Competition		
	SuperMoto	00-01	<b>HF</b>
LC4	620 RXC	95-95	<b>SI</b>
LC4	620 Supercompetition		
		01-01	<b>HF</b>
SC	620	99-00	<b>SI</b>
SX	620	95-99	<b>RSI</b>



Available compounds

**HF • HS • LS • RQ • CS • SI • RSI • H.HF • H.CT • H.LS SBS 671**

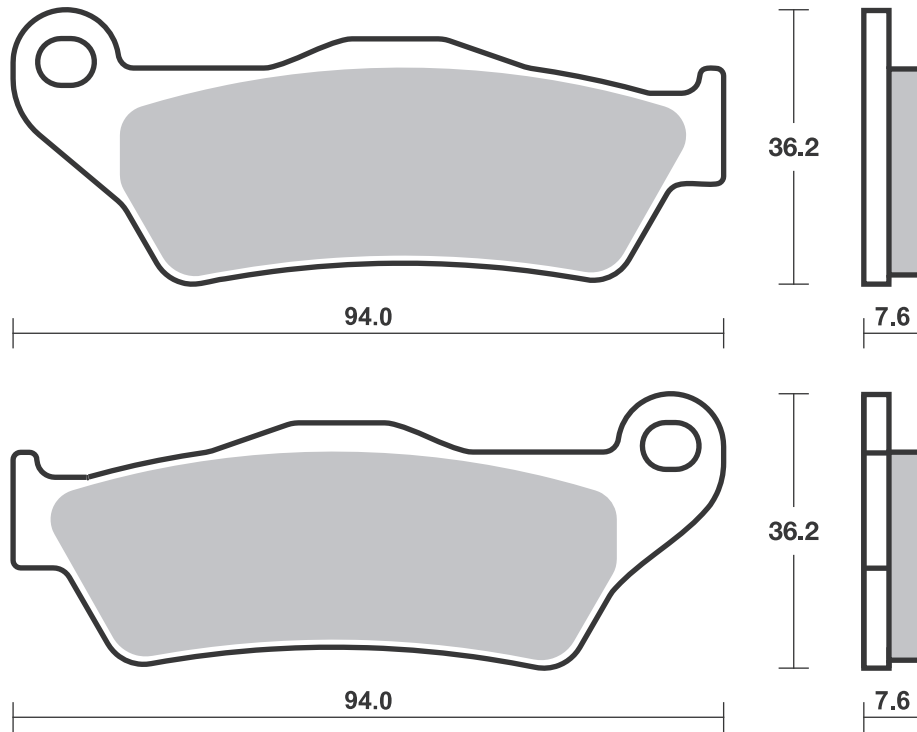



<b>KTM</b>			
LC4	625 SC Supermoto	02-04	<b>HF</b>
SXC	625	03-04	<b>HF</b>
LC4	640 Adventure	99-04	<b>HF</b>
LC4-E	640 Enduro	99-04	<b>HF</b>
LC4-E	640 Supermoto	99-02	<b>HF</b>
LC4	660 Rallye	01-03	<b>HF</b>
	790 Adventure	19-20	<b>LS</b>
	790 Adventure R	19-20	<b>LS</b>
	790 Adventure R Rallye	20-20	<b>LS</b>
	890 Adventure R	21-21	<b>LS</b>
	950 R Superenduro	06-08	<b>LS</b>
	950 SM	05-07	<b>LS</b>
	950 SM R	07-09	<b>LS</b>
LC8	950 Adventure	02-07	<b>LS</b>
	990 Adventure R	10-12	<b>LS</b>
	990 Adventure, Adventure S, ABS	06-11	<b>LS</b>
	990 Supermoto	07-11	<b>LS</b>
	990 Supermoto R	10-10	<b>LS</b>
	990 Supermoto T	09-13	<b>LS</b>
	1050 Adventure	15-16	<b>LS</b>
	1090 Super Adventure	17-19	<b>LS</b>
	1090 Super Adventure R	17-20	<b>LS</b>
	1190 Adventure	13-16	<b>LS</b>
	1290 Super Adventure	15-16	<b>LS</b>
	1290 Super Adventure R	17-20	<b>LS</b>
	1290 Super Adventure S	17-20	<b>LS</b>
	1290 Super Adventure T	17-19	<b>LS</b>
<b>MAICO</b>			
	250 Motocross/Enduro	99-01	<b>SI</b>
	500 Motocross/Enduro	99-99	<b>SI</b>
	500 Supermotard	99-99	<b>HF</b>
<b>MOTO-GUZZI</b>			
V100	1042 Mandello	22-22	<b>LS</b>
ES	1100 Quota	99-03	<b>HF</b>
V	1100 Brevia, ABS	05-07	<b>LS</b>
	1200 Griso 8V	07-13	<b>LS</b>
	1200 Griso 8V SE	18-18	<b>LS</b>
	1200 Norge	06-14	<b>LS</b>
	1200 Norge GT 8V	10-13	<b>LS</b>
	1200 Sport	07-08	<b>LS</b>
	1200 Sport 8V	12-13	<b>LS</b>
	1200 Sport 8V SE	12-15	<b>LS</b>
	1200 Stelvio	08-11	<b>LS</b>
	1200 Stelvio 8V SE	12-16	<b>LS</b>
	1200 Stelvio NTX	09-11	<b>LS</b>
V	1200 Brevia	08-13	<b>LS</b>
<b>MOTO-MORINI</b>			
	650 Seiemmezzo	20-20	<b>LS</b>
	650 X-Cape	20-20	<b>LS</b>
	1200 Granferro	10-10	<b>LS</b>
	1200 Granpasso	08-13	<b>LS</b>
	1200 GT	10-10	<b>LS</b>
	1200 Scrambler	09-10	<b>LS</b>



<b>ROYAL ENFIELD</b>			
	411 Himalayan	19-20	<b>HF</b>
	500 Bullet	20-20	<b>HS</b>
	500 Bullet Trials	20-20	<b>HS</b>
	500 Classic	19-19	<b>HF</b>
<b>SHERCO</b>			
SE-R	125	17-19	<b>SI</b>
SE	250 , R	14-14	<b>SI</b>
SE	250 2.5i Enduro	06-11	<b>SI</b>
SE	250 F, F-R	14-19	<b>SI</b>
SE	250 i/iR	12-13	<b>SI</b>
SE	250 i-F	13-13	<b>SI</b>
SX	250 2.5i-F	09-11	<b>RSI</b>
SCF-R	300	16-19	<b>SI</b>
SE	300 , R	14-19	<b>SI</b>
SE	300 3.0i-F	10-11	<b>SI</b>
SE	300 F, F-R	14-19	<b>SI</b>
SE	300 i/iR	12-13	<b>SI</b>
SE	300 i-F	13-13	<b>SI</b>
SE	450 4.5i Enduro	04-11	<b>SI</b>
SE	450 F, F-R	14-19	<b>SI</b>
SE	450 iR	12-13	<b>SI</b>
SE	510 5.1i Enduro	06-11	<b>SI</b>
SE	510 iR	12-13	<b>SI</b>
<b>SWM</b>			
RS	300 R	15-20	<b>SI</b>
RS	500 R	15-20	<b>SI</b>
<b>TM</b>			
	80 Cross	96-00	<b>RSI</b>
MX	85	01-12	<b>RSI</b>
EN	125 Enduro	01-17	<b>SI</b>
MX	125	96-04	<b>RSI</b>
	250 E	95-00	<b>RSI</b>
EN	250 Enduro	01-15	<b>SI</b>
EN	250 F Enduro	00-04	<b>SI</b>
MX	250	01-20	<b>RSI</b>
MX	250 F	01-20	<b>RSI</b>
EN	300 Enduro	01-05	<b>SI</b>
FT	300	17-19	<b>RSI</b>
MX	300	98-04	<b>RSI</b>
	320	96-97	<b>RSI</b>
	400 F	00-01	<b>RSI</b>
	400 F Enduro	01-01	<b>SI</b>
EN	450 F Enduro	02-17	<b>SI</b>
FT	450 Fi	17-19	<b>RSI</b>
MX	450 F	02-20	<b>RSI</b>
EN	530 F Enduro	01-05	<b>SI</b>
FT	530 Fi	17-19	<b>RSI</b>
MX	530 F	01-20	<b>RSI</b>
<b>TRIUMPH</b>			
	800 Tiger XCA	18-18	<b>HS</b>
	800 Tiger XCX	18-20	<b>HS</b>
	800 Tiger XRT	18-18	<b>HS</b>
	800 Tiger XRX	18-18	<b>HS</b>
	800 Tiger XRX Low	18-20	<b>HS</b>
	1200 Bonneville		
	Bobber Black	18-19	<b>HS</b>
	1200 Speedmaster	18-19	<b>HS</b>
<b>VERTEMATI</b>			
C	500 Cross	02-04	<b>RSI</b>
E	501 Enduro	02-04	<b>SI</b>
S	501 Supermotard	02-04	<b>HF</b>



<b>VOR</b>			
	400 Cross	00-01	<b>RSI</b>
	400 Enduro	00-01	<b>SI</b>
EN	400	02-03	<b>SI</b>
MX	400	02-02	<b>RSI</b>
EN	450	02-04	<b>SI</b>
MX	450	02-04	<b>RSI</b>
	500 492 Enduro	99-99	<b>SI</b>
	500 495 Cross	99-99	<b>RSI</b>
EN	530	02-04	<b>SI</b>
MX	530	02-04	<b>RSI</b>
<b>YAMAHA</b>			
FZ25	250	19-19	<b>HF</b>
XT	660 Z Tenere	08-15	<b>HS</b>
XT	660 Z Tenere ABS	11-15	<b>HS</b>
XTZ	700 Tenere	19-21	<b>HS</b>
<b>ZERO</b>			
FX	ZF2.8	15-15	<b>HS</b>
FX	ZF5.7	15-15	<b>HS</b>

Available compounds

**HF • HS • LS • RQ • CS • SI • RSI • H.HF • H.CT • H.LS SBS 671**

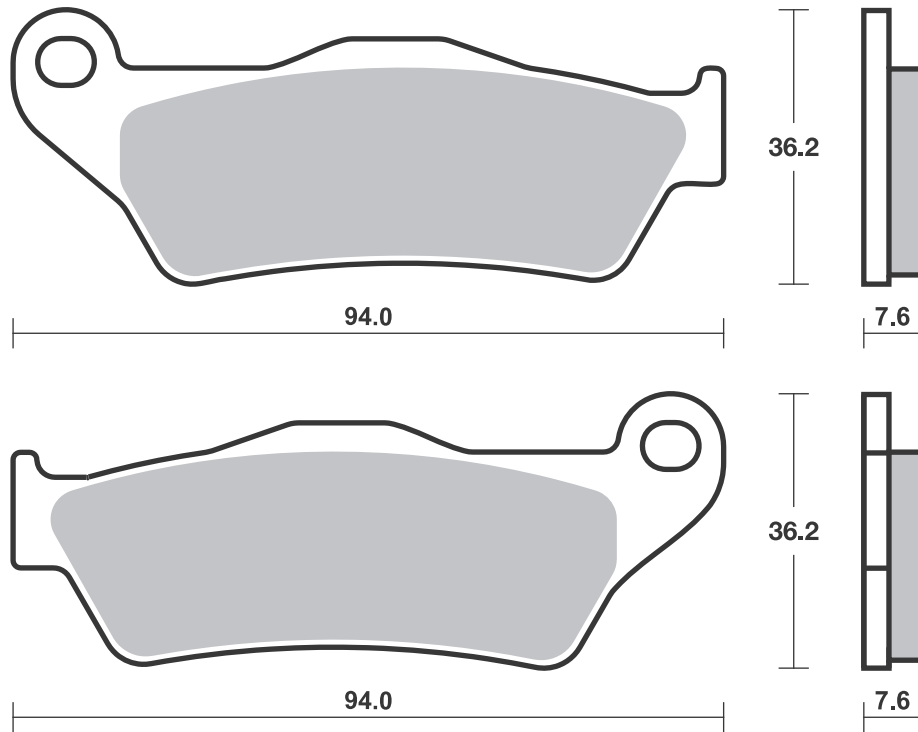



Available compounds

HF

SBS 672

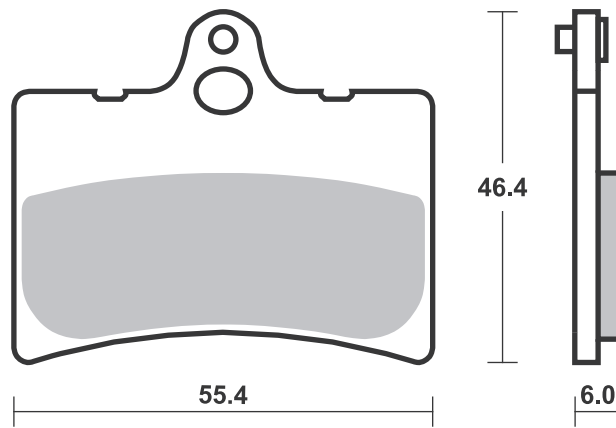

Available compounds

HF • HS • LS • SI • RSI • H.HF • H.CT • H.HS • H.LS

SBS 674

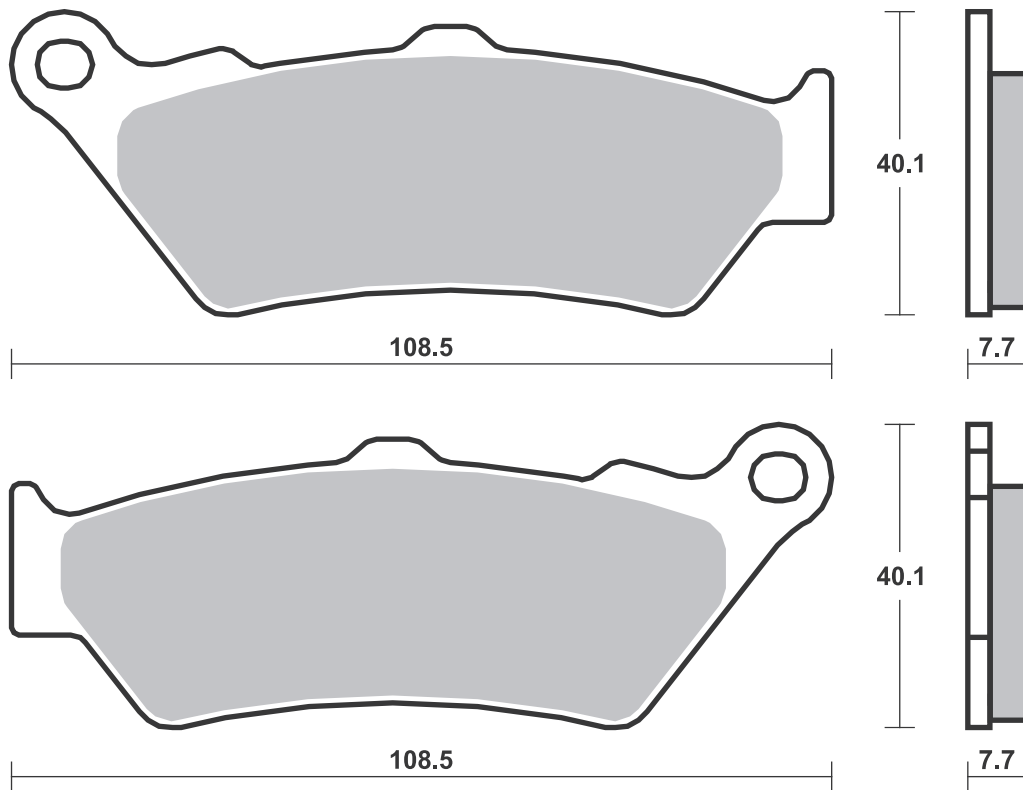

**SBS 674 Recommended compound**

<b>MOTO-GUZZI</b>			
1400 California			
Custom	13- 15	<b>LS</b>	
1400 California			
Touring	13- 15	<b>LS</b>	
1400 California			
Touring SE	16- 17	<b>LS</b>	
1400 Eldorado	15- 17	<b>LS</b>	
MGX-21 1400 Flying			
Fortress	15- 17	<b>LS</b>	

<b>MOTO-MORINI</b>			
649 X-Cape	22- 22	<b>HS</b>	
650 Seiemmezzo	20- 20	<b>HS</b>	
650 X-Cape	20- 20	<b>HS</b>	
1200 Granpasso	08- 13	<b>HS</b>	
1200 GT	10- 10	<b>HS</b>	
1200 Scrambler	09- 10	<b>HS</b>	

<b>ROYAL ENFIELD</b>			
535 Continental			
GT	14- 17	<b>HS</b>	
650 Continental			
GT	20- 20	<b>HS</b>	
650 Interceptor	19- 20	<b>HS</b>	

<b>SWM</b>			
600 Superdual			
GT Pack	18- 18	<b>HS</b>	
600 Superdual T	18- 20	<b>HS</b>	
600 Superdual X	18- 20	<b>HS</b>	



<b>TRIUMPH</b>			
1200 Scrambler XC	19- 20	<b>LS</b>	
1200 Scrambler XE	19- 20	<b>LS</b>	
1600 Thunderbird	09- 18	<b>LS</b>	
1700 Thunderbird			
Commander	14- 18	<b>LS</b>	
1700 Thunderbird LT	14- 18	<b>LS</b>	
1700 Thunderbird			
Nightstorm	14- 18	<b>LS</b>	
1700 Thunderbird			
Storm	11- 18	<b>LS</b>	
2300 Rocket III	04- 13	<b>LS</b>	
2300 Rocket III			
Classic	07- 13	<b>LS</b>	
2300 Rocket III			
Roadster	10- 18	<b>LS</b>	
2300 Rocket III			
Touring	13- 14	<b>LS</b>	
2300 Rocket X	15- 15	<b>LS</b>	

<b>VICTORY</b>			
1200 Octane	17- 17	<b>H.HS</b>	
1500 Kingpin	04- 05	<b>H.LS</b>	
1500 Touring Cruiser	03- 06	<b>H.LS</b>	
1500 V92C Cruiser	98- 02	<b>H.LS</b>	
1500 V92C Deluxe	01- 02	<b>H.LS</b>	
1500 V92SC Sport			
Cruiser	00- 02	<b>H.LS</b>	
1500 Vegas	03- 05	<b>H.LS</b>	
1500 Vegas 8-Ball	05- 05	<b>H.LS</b>	
1634 Hammer	05- 07	<b>H.LS</b>	



<b>VICTORY</b>			
1634 Hammer S	06- 08	<b>H.LS</b>	
1634 Kingpin	06- 07	<b>H.LS</b>	
1634 Kingpin Tour	06- 07	<b>H.LS</b>	
1634 Vegas	06- 07	<b>H.LS</b>	
1634 Vegas 8-Ball	06- 07	<b>H.LS</b>	
1634 Vegas Jackpot	06- 07	<b>H.LS</b>	

<b>YAMAHA</b>			
XT 660 R	04- 11	<b>HS</b>	

<b>ZERO</b>			
DS	ZF12.5	15- 15	<b>HS</b>
DS	ZF13.0	16- 17	<b>HS</b>
DS	ZF9.4	15- 15	<b>HS</b>
DS	ZF9.8	16- 17	<b>HS</b>
DSR	ZF13.0	16- 17	<b>HS</b>
FX	ZF3.3	16- 17	<b>HS</b>
FX	ZF6.5	16- 17	<b>HS</b>
FXS	ZF3.3	16- 17	<b>HS</b>
FXS	ZF6.5	16- 17	<b>HS</b>
S	ZF12.5	15- 15	<b>HS</b>
S	ZF13.0	16- 17	<b>HS</b>
S	ZF9.4	15- 15	<b>HS</b>
S	ZF9.8	16- 17	<b>HS</b>
SR	ZF12.5	15- 15	<b>HS</b>
SR	ZF13.0	16- 17	<b>HS</b>

**SBS 675 Recommended compound**

<b>APRILIA</b>			
650 Pegaso			
Strada	05- 09	<b>LS</b>	
660 Tuareg	22- 22	<b>LS</b>	
750 Dorsoduro			
Factory	12- 13	<b>LS</b>	
SL 750 Shiver GT,			
ABS	09- 12	<b>LS</b>	
SL 750 Shiver, ABS	07- 18	<b>LS</b>	
SMV 750 Dorsoduro	08- 18	<b>LS</b>	
NA 850 Mana	07- 07	<b>LS</b>	
1200 Caponord	13- 19	<b>LS</b>	
1200 Caponord			
Rally	15- 19	<b>LS</b>	
1200 Caponord			
Travel Pack	16- 19	<b>LS</b>	
1200 Dorsoduro,			
ABS	11- 14	<b>LS</b>	

<b>BENELLI</b>			
BX 449 Cross	07- 09	<b>RSI</b>	
BX 505 Enduro	08- 08	<b>SI</b>	

<b>BMW</b>			
G 310 GS	17- 22	<b>LS</b>	
G 310 R	16- 22	<b>LS</b>	
F 650 , ST	94- 00	<b>HF</b>	
F 650 CS Scarver	02- 06	<b>LS</b>	
F 650 GS	08- 12	<b>LS</b>	
F 650 GS ABS	01- 07	<b>HF</b>	



<b>BMW</b>			
F 650 GS ABS	08- 12	<b>LS</b>	
F 650 GS Dakar	01- 07	<b>HF</b>	
F 650 GS, Rallye	01- 07	<b>HF</b>	
F 650 ST Strada	97- 01	<b>HF</b>	
G 650 GS	09- 15	<b>LS</b>	
G 650 GS Sertao	12- 14	<b>LS</b>	
G 650 Xchallenge	06- 07	<b>LS</b>	
G 650 Xcountry	06- 09	<b>LS</b>	
G 650 Xmoto	06- 07	<b>LS</b>	
F 700 GS	13- 16	<b>LS</b>	
F 750 GS	18- 22	<b>LS</b>	
F 800 GS	08- 20	<b>LS</b>	
F 800 GT	13- 20	<b>LS</b>	
F 800 R	09- 18	<b>LS</b>	
F 800 S	06- 10	<b>LS</b>	
F 800 ST	06- 12	<b>LS</b>	
F 800 ST Touring	11- 12	<b>LS</b>	
F 850 GS	18- 22	<b>LS</b>	
F 850 GS Adventure	18- 22	<b>LS</b>	
R 850 RT	96- 01	<b>LS</b>	
F 900 R	20- 22	<b>LS</b>	
F 900 XR	20- 22	<b>LS</b>	
S 1000 R	13- 19	<b>LS</b>	
S 1000 RR (Hayes cal.)	09- 21	<b>LS</b>	
S 1000 RR (Nissin cal.)	21- 22	<b>LS</b>	
S 1000 RR HP4	12- 14	<b>LS</b>	

<b>BREMBO RACING CALIPERS</b>			
Motocross Caliper	22.2180.20		



<b>CCM</b>			
GP 450	16- 16	<b>SI</b>	
604 600 RS	01- 01	<b>HF</b>	
604E 600 Sport	99- 01	<b>SI</b>	
604E 600 Supermoto	99- 01	<b>SI</b>	
C25 600	96- 98	<b>SI</b>	
644 DS	03- 06	<b>HF</b>	
644 R30	02- 06	<b>HF</b>	

<b>CF MOTO</b>			
400 NK Efi	17- 17	<b>LS</b>	
650 NK	14- 16	<b>LS</b>	
650 NK Efi	17- 17	<b>LS</b>	
650 TK	14- 15	<b>LS</b>	

<b>DUCATI</b>			
400 Scrambler			
Sixty Two	16- 20	<b>LS</b>	
797 Monster	17- 21	<b>LS</b>	
797 Monster+	17- 20	<b>LS</b>	
803 Scrambler	17- 18	<b>LS</b>	
803 Scrambler			
Classic	15- 19	<b>LS</b>	
803 Scrambler CR	17- 20	<b>LS</b>	
803 Scrambler CR			
Cafe Racer	17- 20	<b>LS</b>	
803 Scrambler DS			
Desert Sled	17- 22	<b>LS</b>	
803 Scrambler			
Enduro	15- 16	<b>LS</b>	



Available compounds

**HF • HS • LS • SI • RSI • H.HF • H.CT • H.HS • H.LS**

**SBS 674**

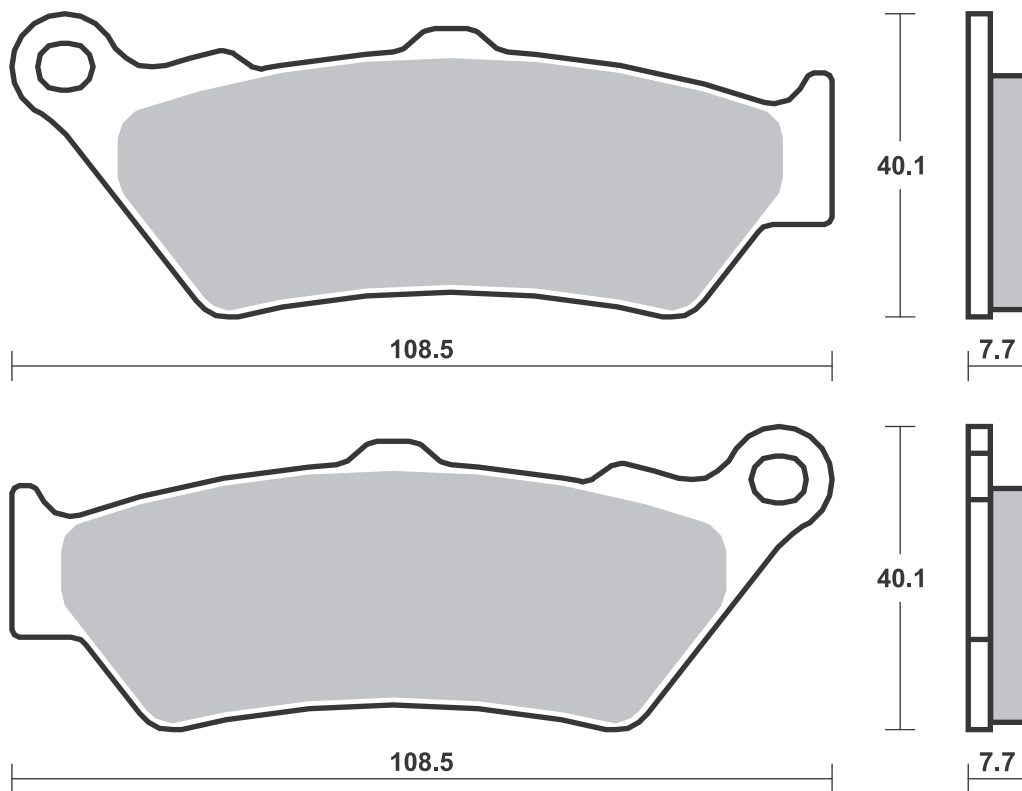

Available compounds

**HF • LS • RQ • CS • SI • RSI • H.HF • H.CT • H.LS**

**SBS 675**

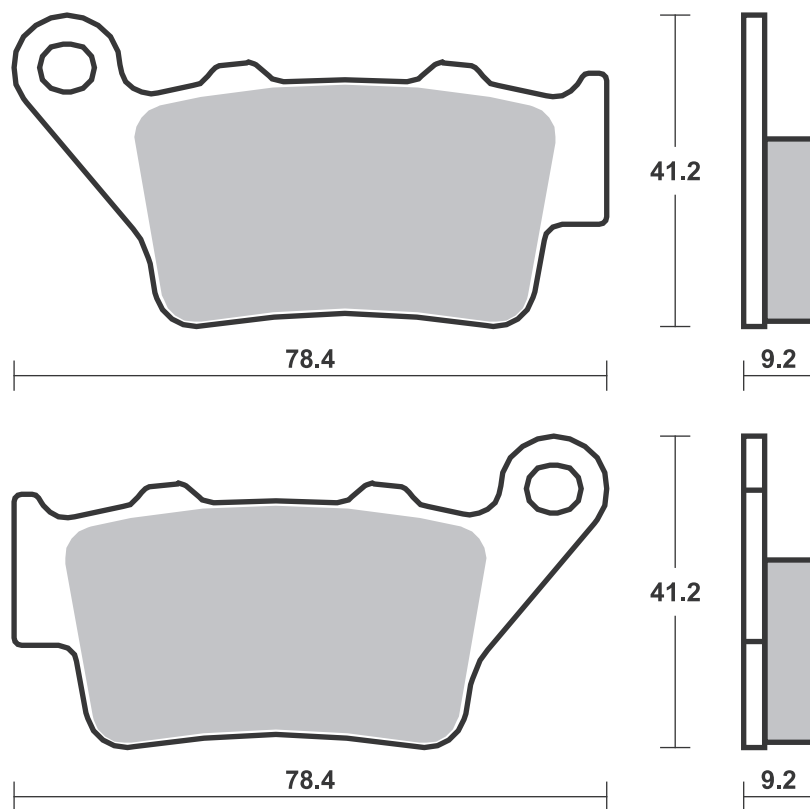



<b>DUCATI</b>			
803 Scrambler			
Flat Track Pro	16-16		<b>LS</b>
803 Scrambler			
Full Throttle	15-20		<b>LS</b>
803 Scrambler Icon	15-22		<b>LS</b>
803 Scrambler Icon			
Dark	20-22		<b>LS</b>
803 Scrambler			
Mach 2.0	18-18		<b>LS</b>
803 Scrambler SCR	20-20		<b>LS</b>
803 Scrambler			
Street Classic	17-18		<b>LS</b>
803 Scrambler			
Urban Enduro	15-18		<b>LS</b>
803 Scrambler			
Urban Motard	22-22		<b>LS</b>
1000 Biposto	07-08		<b>LS</b>
1000 GT	05-10		<b>LS</b>
1000 GT Touring	09-10		<b>LS</b>
1000 Paul Smart	05-08		<b>LS</b>
1000 Sport	05-09		<b>LS</b>
1000 Sport S	05-09		<b>LS</b>
1100 Scrambler	18-19		<b>LS</b>
1100 Scrambler			
Dark Pro	20-22		<b>LS</b>
1100 Scrambler			
Desert X	20-20		<b>LS</b>
1100 Scrambler Pro	20-22		<b>LS</b>
1100 Scrambler			
Special	18-19		<b>LS</b>
1100 Scrambler			
Sport	18-19		<b>LS</b>
1100 Scrambler			
Sport Pro	20-22		<b>LS</b>
1100 Scrambler			
Tribute Pro	22-22		<b>LS</b>

<b>FANTIC</b>			
125 Caballero Flat			
Track	17-17		<b>LS</b>
125 Caballero Rally	22-22		<b>HF</b>
125 Caballero			
Scrambler	22-22		<b>HF</b>
500 Caballero	17-17		<b>LS</b>
500 Caballero			
Explorer	22-22		<b>HF</b>
500 Caballero Rally	22-22		<b>HF</b>
500 Caballero			
Scrambler	22-22		<b>HF</b>
500 Caballero			
Six Days	22-22		<b>HF</b>

<b>GAS GAS</b>			
EC 125		97-99	<b>SI</b>
EC 200		99-99	<b>SI</b>
EC 250		97-99	<b>SI</b>
MC 250		97-99	<b>RSI</b>
EC 300		99-99	<b>SI</b>

<b>HARLEY DAVIDSON</b>			
975 Bronx		20-21	<b>H.LS</b>
1250 Pan America		21-22	<b>LS</b>

<b>HIGHLAND</b>			
450 MX		06-09	<b>RSI</b>
950 V2 Motard		00-08	<b>HF</b>
950 V2 Outback		99-08	<b>HF</b>



<b>HONDA</b>			
CBR 250 R (Bybre cal)		11-11	<b>LS</b>

<b>HUSABERG</b>			
FC 400		99-02	<b>RSI</b>
FE 400 ,S,E		99-03	<b>SI</b>
FS 400 e, c		01-03	<b>RSI</b>
FC 450		03-08	<b>RSI</b>
FE 450 e		04-08	<b>SI</b>
FS 450 c		06-08	<b>RSI</b>
FS 450 e, c		03-05	<b>RSI</b>
FX 450 e		03-08	<b>RSI</b>
FC 470 , e		01-02	<b>RSI</b>
FX 470 e		01-02	<b>RSI</b>
FC 501		99-01	<b>RSI</b>
FE 501 ,S,E		99-04	<b>SI</b>
FC 550		01-05	<b>RSI</b>
FE 550 e		04-08	<b>SI</b>
FC 600		99-01	<b>RSI</b>
FE 600 ,S,E		99-02	<b>SI</b>
FE 650 e		01-08	<b>SI</b>
FS 650 e, c		01-08	<b>RSI</b>
FX 650 e		01-05	<b>RSI</b>

<b>HUSQVARNA</b>			
CR 125		96-04	<b>RSI</b>
SM 125 S		09-13	<b>HF</b>
SM 125 S 4T		11-13	<b>HF</b>
SM 125 Supermotard,			
S		99-13	<b>HF</b>
TE 125 4T		11-13	<b>HF</b>
WR 125		96-13	<b>SI</b>
WRE 125		96-13	<b>SI</b>
CR 250		96-04	<b>RSI</b>
TC 250		02-03	<b>RSI</b>
TE 250		02-13	<b>SI</b>
WR 250		96-13	<b>SI</b>
TE 350		96-13	<b>SI</b>
WR 360		98-13	<b>SI</b>
SM 400 R		02-02	<b>HF</b>
TE 400		01-13	<b>SI</b>
401 Svartpilen		17-20	<b>LS</b>
401 Vitpilen		17-20	<b>LS</b>
TE 410		96-13	<b>SI</b>
SM 450 R		03-04	<b>HF</b>
SM 450 R		05-05	<b>RSI</b>
TC 450		02-03	<b>RSI</b>
TE 450		02-10	<b>SI</b>
SM 510 R		05-05	<b>RSI</b>
TC 510		02-03	<b>RSI</b>
TE 510		02-10	<b>SI</b>
TE 510 Centennial		04-05	<b>SI</b>
570 Nox		01-03	<b>HF</b>
SM 570 R		01-08	<b>HF</b>
TC 570		01-13	<b>RSI</b>
TE 570		01-13	<b>SI</b>
LT 610		00-02	<b>HF</b>
SM 610 Super Motard,			
S		98-00	<b>HF</b>
TC 610		96-13	<b>RSI</b>
TE 610 Rallye		96-13	<b>RSI</b>
SMR 630		04-08	<b>RSI</b>
TR 650 Strada		13-13	<b>LS</b>
TR 650 Terra		13-13	<b>LS</b>
701 Enduro LR		20-20	<b>LS</b>
701 Svartpilen		18-19	<b>LS</b>
701 Vitpilen		18-20	<b>LS</b>
FE 701 Enduro		17-20	<b>LS</b>



<b>HUSQVARNA</b>			
SM 701 Supermoto		15-20	<b>LS</b>
900 Nuda		12-13	<b>LS</b>
900 Nuda R, ABS		12-13	<b>LS</b>

<b>HYOSUNG</b>			
RX 450 SM		08-11	<b>LS</b>

<b>INDIAN</b>			
1000 Scout Sixty		17-18	<b>H.LS</b>
1200 Scout		17-20	<b>H.LS</b>
1200 Scout Bobber		17-20	<b>H.LS</b>

<b>KTM</b>			
125 Duke		11-19	<b>LS</b>
125 Sting		99-99	<b>HF</b>
125 SuperMoto		00-03	<b>HF</b>
EXC 125 Enduro		99-03	<b>SI</b>
EXE 125		00-00	<b>HF</b>
LC2 125		99-99	<b>HF</b>
RC 125		14-22	<b>LS</b>
SX 125		96-03	<b>RSI</b>
200 Duke		12-17	<b>LS</b>
EXC 200 Enduro		99-03	<b>SI</b>
RC 200		14-22	<b>LS</b>
250 Duke		14-15	<b>LS</b>
EXC 250 Enduro		99-03	<b>SI</b>
EXC 250 Enduro 4T		99-03	<b>SI</b>
RC 250		14-15	<b>LS</b>
RC 250 Upgrade DS		14-15	<b>LS</b>
SX 250		96-02	<b>RSI</b>
EXC 300 Enduro		99-03	<b>SI</b>
MX 360		96-97	<b>SI</b>
SX 360		96-97	<b>RSI</b>
XC 360		96-97	<b>SI</b>
EXC 380 Enduro		99-99	<b>SI</b>
MX 380		98-98	<b>SI</b>
SX 380		98-02	<b>RSI</b>
XC 380		98-03	<b>SI</b>
390 Adventure		20-20	<b>LS</b>
390 Duke		13-20	<b>LS</b>
RC 390		14-22	<b>LS</b>
RC 390 Upgrade DS		14-22	<b>LS</b>
EXC 400 Racing		00-03	<b>SI</b>
LC4-E 400 Enduro		99-02	<b>SI</b>
SC 400		99-00	<b>SI</b>
SX 400 Racing		00-02	<b>RSI</b>
SXC 400 Tiainen Replica		99-00	<b>SI</b>
450 Rally		11-17	<b>SI</b>
EXC 520 Racing		00-02	<b>SI</b>
SX-F 520 Racing		00-02	<b>RSI</b>
EXC 525 Racing		03-03	<b>SI</b>
SX-F 525 Racing		03-03	<b>RSI</b>
SXC 540 Tiainen Replica		99-00	<b>SI</b>
LC4 620 Competition		99-02	<b>SI</b>
LC4 620 Competition			
SuperMoto		00-01	<b>HF</b>
LC4 620 RXC		95-95	<b>SI</b>
LC4 620 Supercompetition			
		01-01	<b>HF</b>
SC 620		99-00	<b>SI</b>
SX 620		95-99	<b>RSI</b>
LC4 625 SC Supermoto		02-04	<b>HF</b>
SMC 625		05-06	<b>HF</b>
SXC 625		03-04	<b>HF</b>
640 Duke		03-06	<b>HF</b>
LC4 640 Adventure		99-07	<b>HF</b>
LC4 640 Supermoto		03-04	<b>HF</b>

Available compounds

HF • LS • RQ • CS • SI • RSI • H.HF • H.CT • H.LS

SBS 675

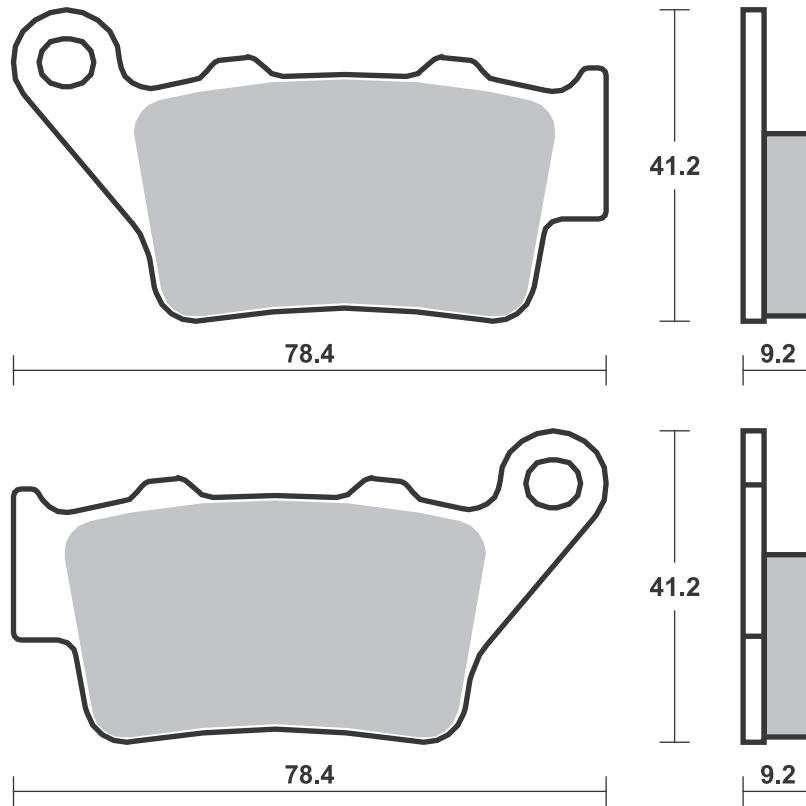



<b>KTM</b>			
LC4-E	640 Enduro	99-04	<b>HF</b>
LC4-E	640 Supermoto	99-02	<b>HF</b>
LC4	660 Rallye	01-03	<b>HF</b>
LC4	660 SM Factory		
	Replica	02-02	<b>RSI</b>
SMC	660 Supermoto	03-07	<b>HF</b>
	690 Duke	08-11	<b>LS</b>
	690 Duke ABS	12-19	<b>LS</b>
	690 Duke R	10-11	<b>LS</b>
	690 Duke R	14-17	<b>LS</b>
	690 Enduro	08-14	<b>LS</b>
	690 Enduro R	09-21	<b>LS</b>
	690 SM	07-11	<b>LS</b>
	690 SMC	08-10	<b>LS</b>
	690 SMC R	14-20	<b>LS</b>
	690 Supermoto R	08-09	<b>LS</b>
	790 Duke	18-20	<b>LS</b>
	890 Duke R	20-20	<b>LS</b>
	990 Super Duke	04-13	<b>LS</b>
	990 Super Duke R	09-13	<b>LS</b>

<b>MAICO</b>			
	250 Motocross/ Enduro	99-01	<b>SI</b>
	500 Motocross/ Enduro	99-99	<b>SI</b>
	500 Supermotard	99-99	<b>HF</b>

<b>ROYAL ENFIELD</b>			
	411 Himalayan	19-20	<b>HF</b>
	500 Bullet	20-20	<b>LS</b>
	500 Bullet Trials	20-20	<b>LS</b>
	500 Classic	19-19	<b>HF</b>
	535 Continental GT	14-17	<b>LS</b>
	650 Continental GT	20-20	<b>LS</b>
	650 Interceptor	19-20	<b>LS</b>

<b>SWM</b>			
	600 Superdual		
	GT Pack	18-18	<b>LS</b>
	600 Superdual T	18-20	<b>LS</b>
	600 Superdual X	18-20	<b>LS</b>
	650 Superdual	15-18	<b>LS</b>



<b>TM</b>			
	80 Cross	96-00	<b>RSI</b>
MX	125	96-00	<b>RSI</b>
	250 E Rallye	95-00	<b>RSI</b>
EN	250 F Enduro	00-00	<b>SI</b>
MX	300	98-00	<b>RSI</b>
	320	96-97	<b>RSI</b>
	400 F	00-00	<b>RSI</b>

<b>TRIUMPH</b>			
	660 Street Triple S	17-20	<b>LS</b>
	675 Daytona R Triple	13-18	<b>LS</b>
	675 Daytona Triple	13-18	<b>LS</b>
	675 Street Triple	13-17	<b>LS</b>
	675 Street Triple R	13-17	<b>LS</b>
	675 Street Triple RX	15-16	<b>LS</b>
	765 Daytona Moto2	20-22	<b>LS</b>
	765 Street Triple R	17-20	<b>LS</b>
	765 Street Triple R		
	Low	17-18	<b>LS</b>
	765 Street Triple RS	17-20	<b>LS</b>
	765 Street Triple S	17-20	<b>LS</b>
	850 Tiger Sport	21-21	<b>LS</b>
	900 Tiger	20-21	<b>LS</b>
	900 Tiger GT	20-21	<b>LS</b>
	900 Tiger Rally	20-21	<b>LS</b>

<b>VERTEMATI</b>			
C	500 Cross	02-04	<b>RSI</b>
E	501 Enduro	02-04	<b>SI</b>
S	501 Supermotard	02-04	<b>HF</b>

<b>VICTORY</b>			
	1200 Octane	17-17	<b>H.LS</b>

<b>VOR</b>			
	400 Cross	00-01	<b>RSI</b>
	400 Enduro	00-01	<b>SI</b>
EN	400	02-03	<b>SI</b>
MX	400	02-02	<b>RSI</b>
SM	400	02-02	<b>RSI</b>
EN	450	02-04	<b>SI</b>
MX	450	02-04	<b>RSI</b>
SM	450	02-04	<b>RSI</b>
	500 492 Enduro	99-99	<b>SI</b>



<b>VOR</b>			
	500 492 Super		
	Motard	00-01	<b>HF</b>
	500 495 Cross	99-99	<b>RSI</b>
EN	530	02-04	<b>SI</b>
MX	530	02-04	<b>RSI</b>
SM	530	02-04	<b>RSI</b>

<b>YAMAHA</b>			
WR	125 R, XY	09-16	<b>HF</b>
XT	660 R	04-11	<b>LS</b>
XT	660 X	04-13	<b>LS</b>
XT	660 Z Tenere	08-15	<b>LS</b>
XT	660 Z Tenere ABS	11-15	<b>LS</b>
XTZ	700 Tenere	19-21	<b>LS</b>

<b>ZERO</b>			
DS	ZF11.4	14-14	<b>LS</b>
DS	ZF12.5	15-15	<b>LS</b>
DS	ZF13.0	16-17	<b>LS</b>
DS	ZF8.5	14-14	<b>LS</b>
DS	ZF9.4	15-15	<b>LS</b>
DS	ZF9.8	16-17	<b>LS</b>
DSR	ZF13.0	16-17	<b>LS</b>
DSRBF	ZF14.4	19-21	<b>LS</b>
FX	ZF2.8	14-15	<b>LS</b>
FX	ZF3.3	16-17	<b>LS</b>
FX	ZF5.7	14-15	<b>LS</b>
FX	ZF6.5	16-17	<b>LS</b>
FXS	ZF3.3	16-17	<b>LS</b>
FXS	ZF6.5	16-17	<b>LS</b>
S	ZF11.4	14-14	<b>LS</b>
S	ZF12.5	15-15	<b>LS</b>
S	ZF13.0	16-17	<b>LS</b>
S	ZF8.5	14-14	<b>LS</b>
S	ZF9.4	15-15	<b>LS</b>
S	ZF9.8	16-17	<b>LS</b>
SR	ZF11.4	14-14	<b>LS</b>
SR	ZF12.5	15-15	<b>LS</b>
SR	ZF13.0	16-17	<b>LS</b>
SR/F	ZF14.4	19-21	<b>LS</b>
SR/S	ZF14.4	19-21	<b>LS</b>



<b>BRAKING</b>			
Front Harley Davidson			

<b>BUELL</b>			
M2	1200 Cyclone	98-02	<b>HS</b>
S1	1200 Lightning	98-02	<b>HS</b>
S1	1200 Whitelighting	98-02	<b>HS</b>
S3	1200 Thunderbolt	98-02	<b>HS</b>
X1	1200 Lightning	01-02	<b>HS</b>

<b>HHI</b>			
6 Piston Caliper			

<b>KAWASAKI</b>			
ZX-7RR	750 Ninja	96-02	<b>HS</b>



<b>MV AGUSTA</b>			
	750 Brutale,		
	Brutale S	01-05	<b>HS</b>
F4	750	99-02	<b>HS</b>
F4	750 SPR	01-03	<b>HS</b>
	910 Brutale	06-08	<b>HS</b>
	910 Brutale S	06-08	<b>HS</b>
F4	1000 Mamba	04-06	<b>HS</b>
F4	1000 S	04-06	<b>HS</b>
F4	1000 Tamburini	04-06	<b>HS</b>

Available compounds

HF • LS • RQ • CS • SI • RSI • H.HF • H.CT • H.LS

SBS 675

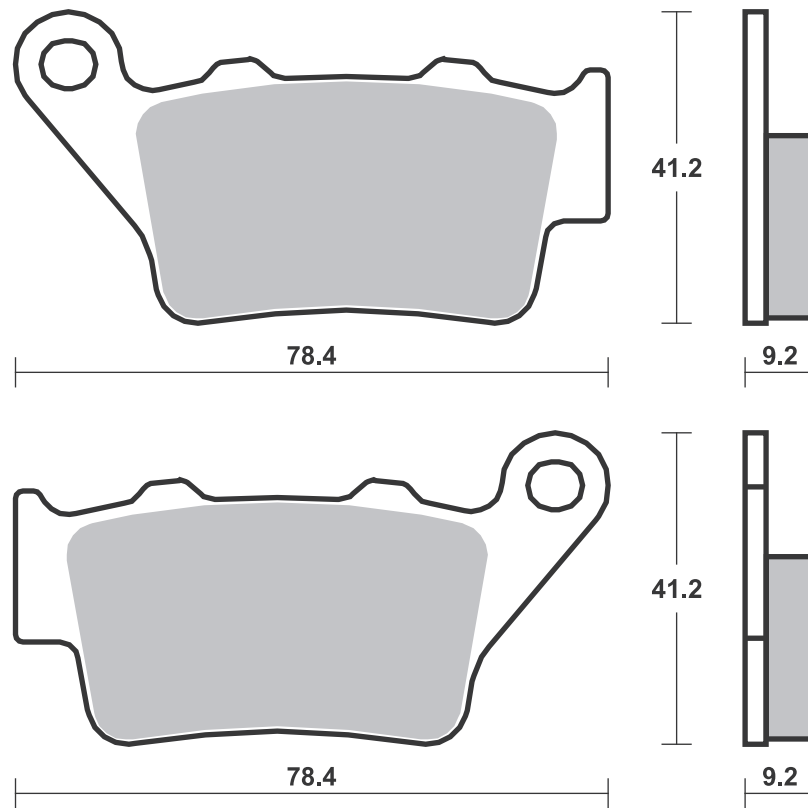

Available compounds

HF • HS • DC • RST • H.HF • H.CT • H.HS

SBS 676

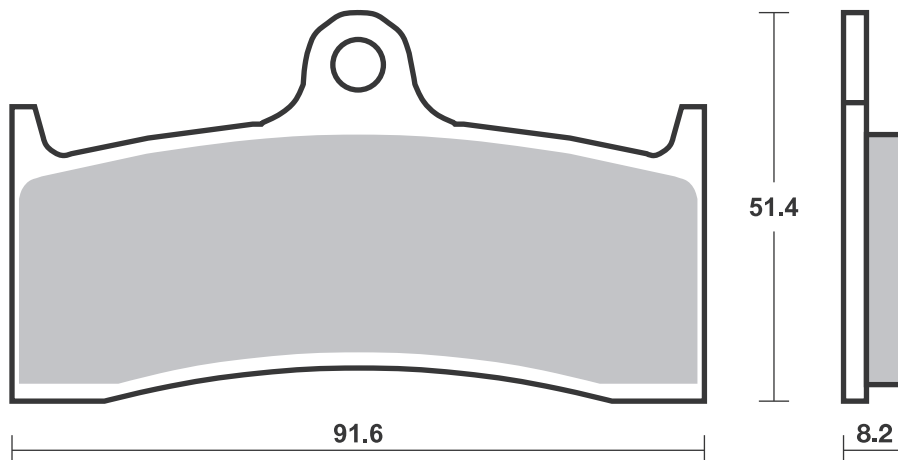



Available compounds

**HF • HS • LS • DC • H.HF • H.CT • H.HS • H.LS**

**SBS 678**

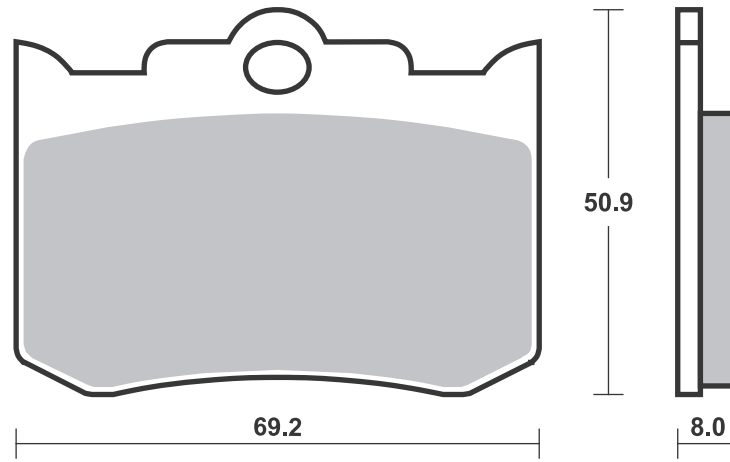

Available compounds

**H.HF**

**SBS 679**

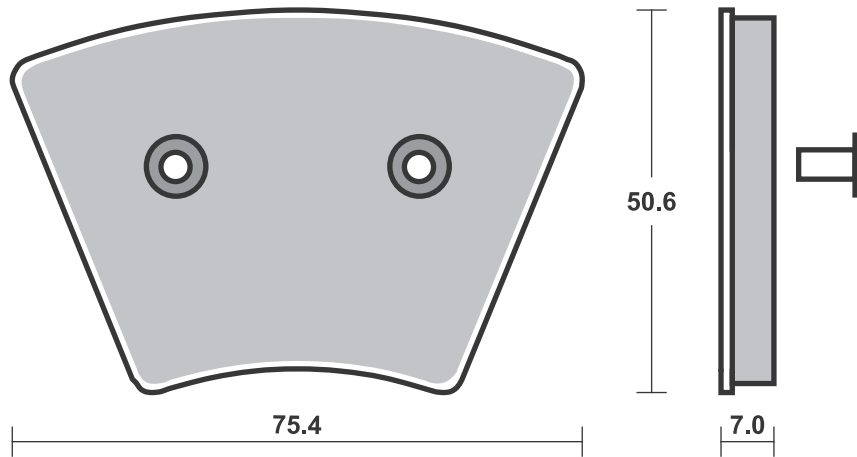





Available compounds

HF

SBS 681

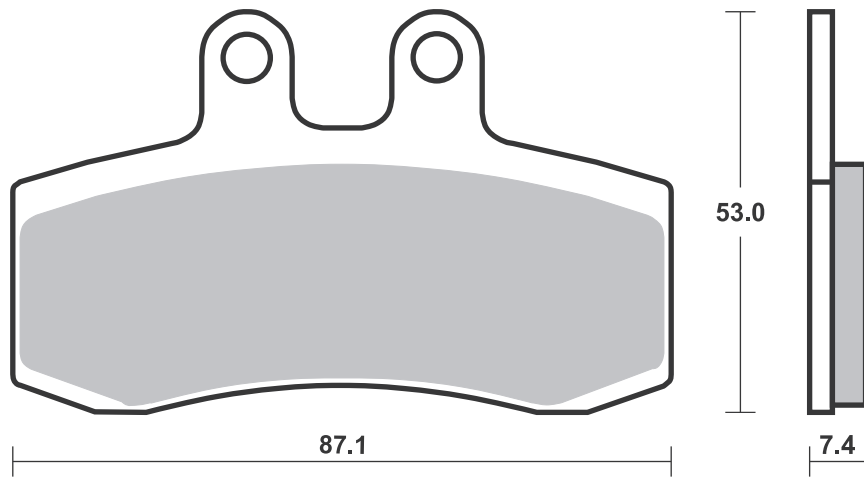

Available compounds

HF

SBS 682

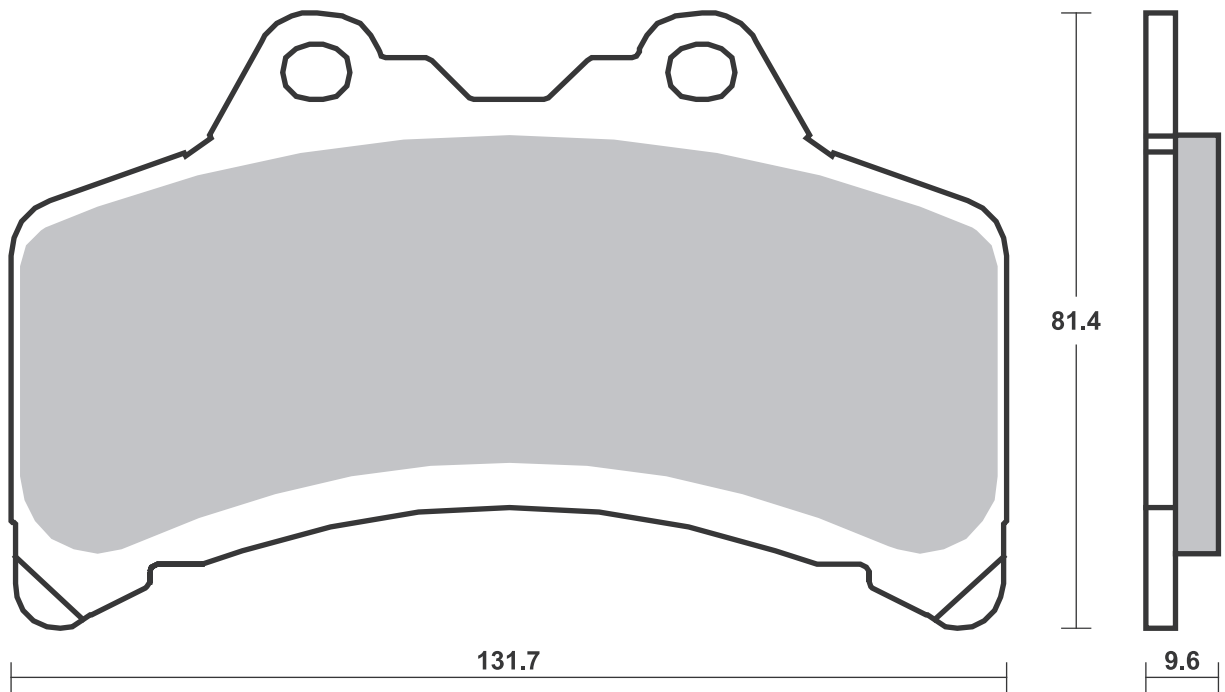

Available compounds

HF • HS • RST • H.HF • H.CT • H.HS

SBS 683

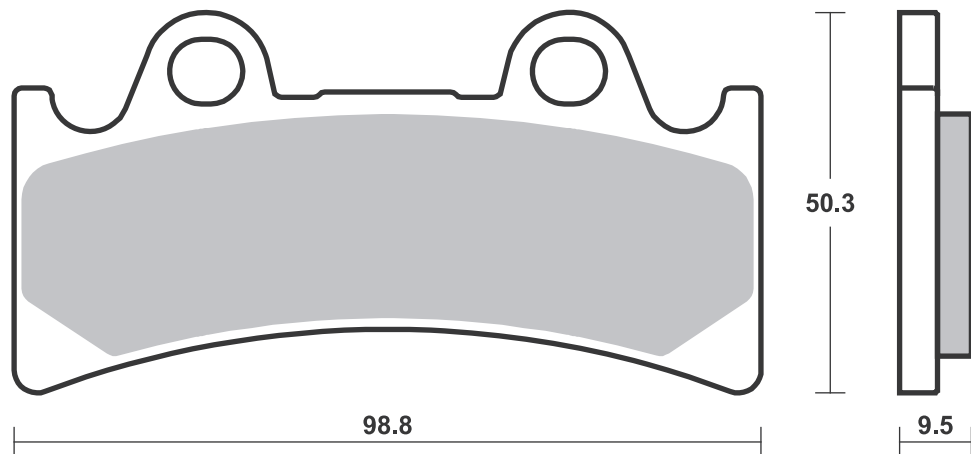

# Applications

## SBS 684 Recommended compound



<b>MZ</b>		
660 (MUZ) Baghira	96-00	HF
660 (MUZ) Black Panther	00-06	HF
660 (MUZ) Mastiff	96-06	HF
660 (MUZ) Street Moto	00-06	HF
660 (MUZ) Super Moto	07-07	HF

<b>SACHS</b>		
500 MadAss	05-08	HF

## SBS 685 Recommended compound



<b>HONDA</b>			
CBR	1000 F, FP	93-99	HS LS

Brake Pad 1:1 Drawings, Compounds, Fitments

Available compounds

**HF**

**SBS 684**

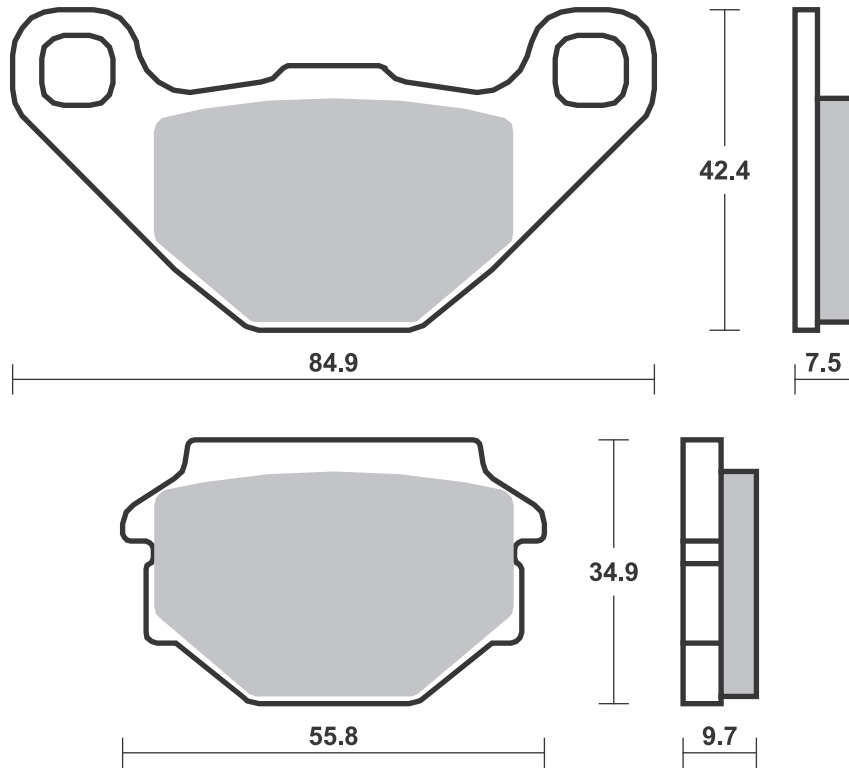

Available compounds

**HF • HS • LS**

**SBS 685**

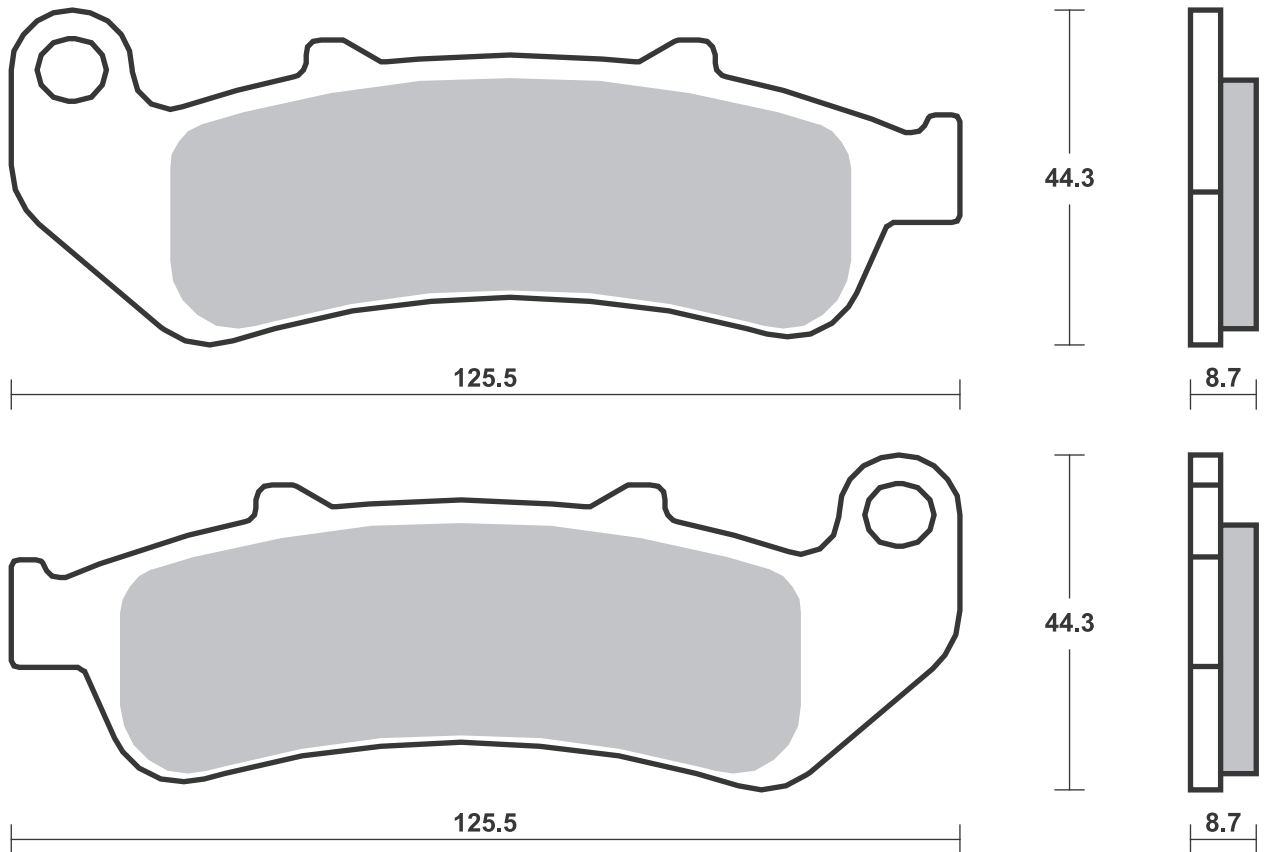

# Applications

## SBS 686 Recommended compound



<b>JAYBRAKE</b>		
4 Piston Caliper A4 P/L		
4 Piston J-Four Caliper		
<b>KAWASAKI</b>		
ZX-6R 600 Ninja	98-01	<b>HS</b>
ZX-6R 636 Ninja	02-02	<b>HS</b>
ZX-7R 750 Ninja	96-03	<b>HS</b>
ZX-9R 900 Ninja	96-01	<b>HS</b>
ZRX 1100	96-00	<b>HS</b>
ZRX 1200	01-04	<b>HS</b>
ZRX 1200 R	01-08	<b>HS</b>
ZRX 1200 S	01-07	<b>HS</b>
ZX-12R 1200 Ninja	00-03	<b>HS</b>
VN 1500 Mean Streak	02-03	<b>HS</b>
VN 1600 Mean Streak	04-04	<b>HS</b>
<b>SUZUKI</b>		
GSX-R 750	94-99	<b>HS</b>
GSX-R 1000	01-02	<b>HS</b>
TL 1000 RW	98-02	<b>HS</b>
GSX-R 1100	93-97	<b>HS</b>
GSF 1200 Bandit	01-05	<b>HS</b>



<b>SUZUKI</b>		
GSF 1200 S Bandit	01-05	<b>HS</b>
GSX-R 1300 Hayabusa	99-07	<b>HS</b>
GSX 1400	02-07	<b>HS</b>
VZ 1600 Marauder	04-04	<b>HS</b>

## SBS 687 Recommended compound



<b>KAWASAKI</b>		
400 Ninja R	11-11	<b>LS</b>
ZR 400 Zephyr	97-01	<b>LS</b>
ZR 550 Zephyr	93-99	<b>LS</b>
ZX-6R 600 (Ninja ZX6)	93-97	<b>LS</b>
ZX-6R 600 (Ninja ZX6R)	95-97	<b>LS</b>
ZX-6R 600 Ninja	98-01	<b>LS</b>
ZX-6R 600 Ninja	07-17	<b>LS</b>
ZX-6RR 600 Ninja	03-06	<b>LS</b>
ZX-6R 636 Ninja	02-06	<b>LS</b>
650 R Ninja	06-08	<b>LS</b>
KLE 650 Versys	07-14	<b>LS</b>
Z 750	04-06	<b>LS</b>
Z 750 S	05-06	<b>LS</b>
ZX-9R 900 Ninja	94-01	<b>LS</b>
1000 Ninja sx	20-20	<b>LS</b>
Z 1000 ABS	15-19	<b>LS</b>
Z 1000 Ninja	14-16	<b>LS</b>
Z 1000 SE	14-16	<b>LS</b>
Z 1000 SX	11-19	<b>LS</b>
ZX-10R 1000 Ninja	04-10	<b>LS</b>
GPZ 1100 (ZX 1100)	95-99	<b>LS</b>

Brake Pad 1:1 Drawings, Compounds, Fitments

Available compounds

HF • HS • DC • RST • H.HF • H.CT • H.HS

SBS 686

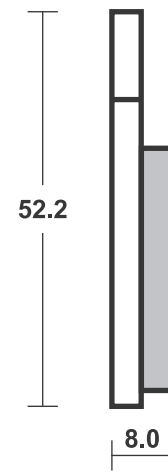
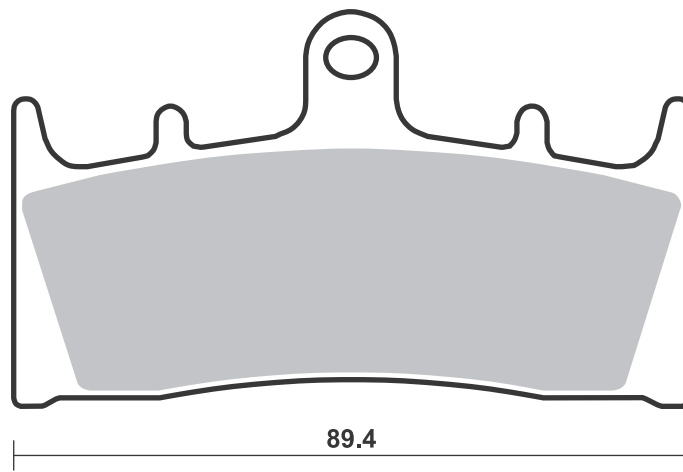

HF / HS - Th. 8.0  
RST / DC - Th. 9.5

Available compounds

HF • LS • RQ

SBS 687

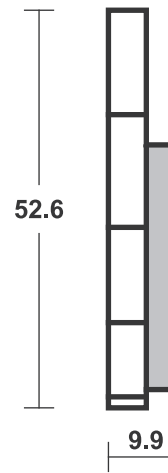
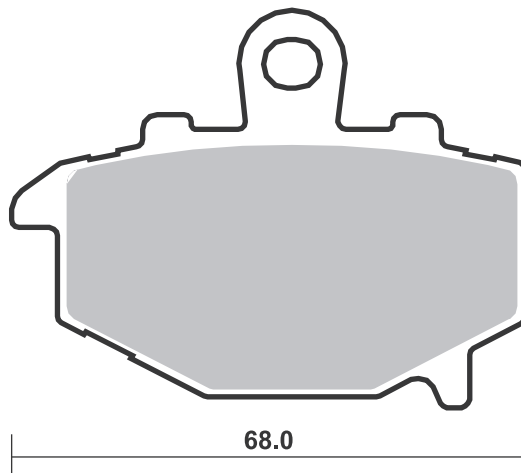
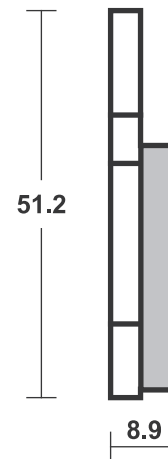
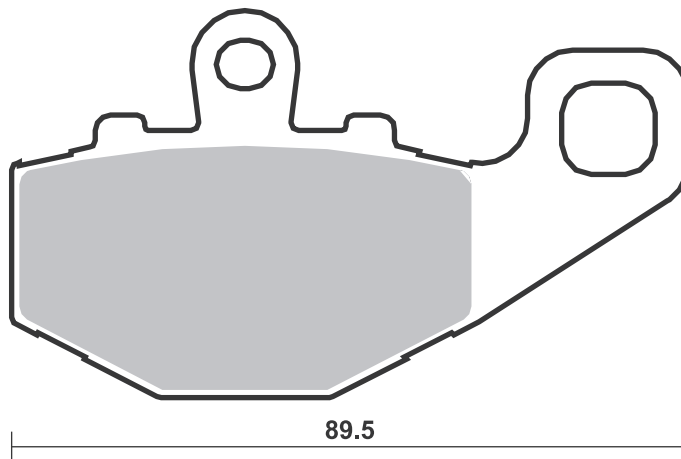

**SBS 688** Recommended compound



**CF MOTO**

125 Papio	17-17	<b>HF</b>
-----------	-------	-----------

**HONDA**

NSF 100	06-06	<b>DC</b>
NSR 150	02-02	<b>HF</b>
CBF 250	04-08	<b>HF</b>
CB 300	10-10	<b>HF</b>

**KYMCO**

125 K-Pipe	13-15	<b>HF</b>
------------	-------	-----------

**TGB**

50 Buffalo	03-03	<b>HF</b>
------------	-------	-----------

**SBS 691** Recommended compound



**KEEWAY**

250 Supershadow	06-09	<b>HF</b>
-----------------	-------	-----------

**MZ**

1000 (MUZ) S	01-02	<b>HF</b>
--------------	-------	-----------

**YAMAHA**

XV 250 Route 66	95-97	<b>HF</b>
XV 250 S Virago	95-07	<b>HS</b>
XVS 250 V-Star	08-14	<b>HS</b>
FZ6 600	04-08	<b>HS</b>
FZ6 600 Fazer	04-08	<b>HS</b>
FZ6R 600	09-14	<b>HS</b>
XV 1100 Virago	99-99	<b>HS</b>
XVS 1100 V-Star	99-06	<b>HS</b>
XVS 1100 V-Star Classic	00-06	<b>HS</b>
XVS 1300 A Midnight Star	07-11	<b>HS</b>
XVS 1300 Custom	14-16	<b>HS</b>
XVS 1300 V-Star	07-14	<b>HS</b>
XVS 1300 V-Star Deluxe	07-14	<b>HS</b>
XVS 1300 V-Star Tourer	07-14	<b>HS</b>

Available compounds

HF • DC

SBS 688

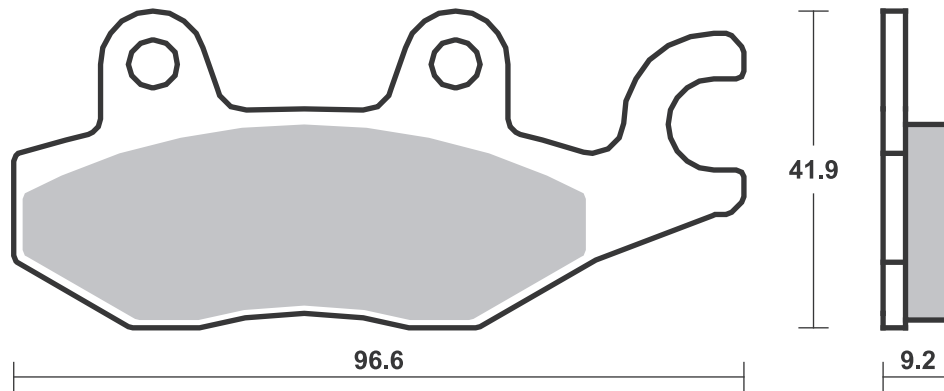
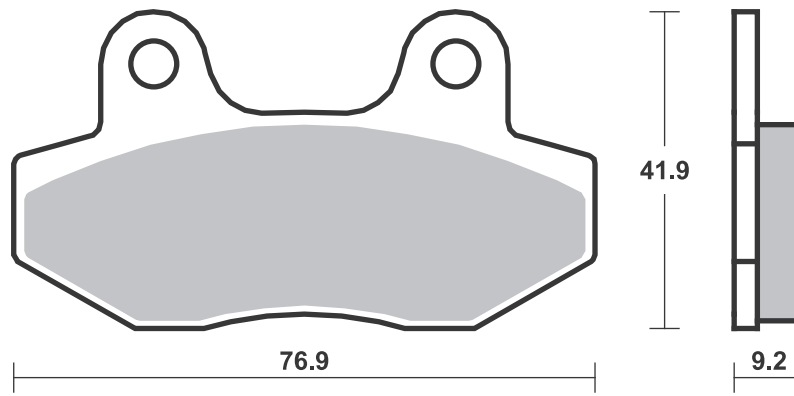

Available compounds

HF • HS

SBS 691

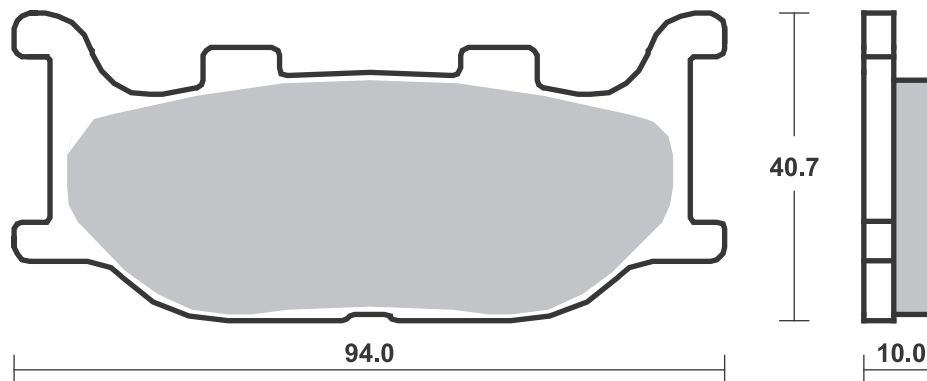

**SBS 692** Recommended compound

<b>APRILIA</b>			
	650 Pegaso	95-00	<b>HF</b>
<b>BUELL</b>			
	all models	94-97	<b>HF</b>
RS	1200	12-12	<b>HF</b>
<b>CAGIVA</b>			
	125 Cross	86-86	<b>SI</b>
WMX	125	89-90	<b>SI</b>
WMX	250	89-90	<b>SI</b>
<b>HUSQVARNA</b>			
CR/WR	125	91-91	<b>SI</b>
WR	240	87-91	<b>SI</b>
CR	250	91-91	<b>SI</b>
WR	260	90-93	<b>SI</b>
TC	610 Cross	91-91	<b>SI</b>
TE	610	91-95	<b>SI</b>
<b>KTM</b>			
MX	125	89-90	<b>SI</b>
MX	125	92-93	<b>SI</b>
MX	250	89-90	<b>SI</b>
MX	250	92-93	<b>SI</b>
MX	500	89-93	<b>SI</b>

**SBS 694** Recommended compound

<b>APRILIA</b>			
MXV	450	09-13	<b>RSI</b>
RXV	450	06-13	<b>SI</b>
RXV	550	06-13	<b>SI</b>
<b>BETA</b>			
RR	125	18-19	<b>SI</b>
RR	250	05-09	<b>SI</b>
	300 Crosstrainer	15-15	<b>SI</b>
RR	300	13-19	<b>SI</b>
RR	350 Efi	15-15	<b>SI</b>
RR	350 Efi Racing	15-15	<b>SI</b>
RR	350 Enduro	12-14	<b>SI</b>
RR	390	15-19	<b>SI</b>
RR	400 Enduro	05-05	<b>SI</b>
RR	430	15-19	<b>SI</b>
RR	430 Racing	15-19	<b>SI</b>
RR	450 Cross Country	12-12	<b>SI</b>
RR	450 Enduro	05-07	<b>SI</b>
RR	480	15-19	<b>SI</b>
RR	480 Racing	15-19	<b>SI</b>
RR	498 Enduro	12-14	<b>SI</b>
RR	525 Enduro	05-13	<b>SI</b>
<b>BIMOTA</b>			
BBX	300 Enduro	12-12	<b>SI</b>
BBX	508 Enduro	12-12	<b>SI</b>



<b>BRACING</b>			
	Front Cross		
<b>CANNONDALE</b>			
MX	400	00-03	<b>RSI</b>
C	440 R	03-03	<b>RSI</b>
E	440 , A, R	03-03	<b>RSI</b>
X	440	03-03	<b>RSI</b>
<b>CPI</b>			
	125 Sahel	02-02	<b>HF</b>
<b>GAS GAS</b>			
	125 Enducross	93-93	<b>SI</b>
EC	125	00-06	<b>SI</b>
MC	125	03-13	<b>RSI</b>
EC	200	00-09	<b>SI</b>
EC	200	17-17	<b>SI</b>
EC	200 Hobby	07-16	<b>SI</b>
XC	200	18-19	<b>SI</b>
EC	250	00-20	<b>SI</b>
EC	250 Enduro GP 18	18-19	<b>SI</b>
EC	250 fse	02-11	<b>SI</b>
MC	250	00-13	<b>SI</b>
XC	250	17-19	<b>SI</b>
EC	300	00-20	<b>SI</b>
EC	300 Enduro GP 18	18-19	<b>SI</b>



<b>GAS GAS</b>			
XC	300	18-19	<b>SI</b>
	400 Pampera	06-09	<b>SI</b>
EC	400 fse	02-02	<b>SI</b>
EC	450 fse	03-15	<b>SI</b>
EC	450 FSR	07-16	<b>SI</b>
EC	515 fsr	08-16	<b>SI</b>
<b>HONDA</b>			
CR	125 R	95-07	<b>RSI</b>
CRE	125	02-07	<b>SI</b>
CRF	125 F	14-21	<b>SI</b>
XLR	125 R	98-01	<b>HF</b>
XR	125 L	03-07	<b>HF</b>
CRF	150 F	03-06	<b>SI</b>
CTX	200	04-06	<b>SI</b>
CRF	230	04-09	<b>SI</b>
CRF	230 L	08-10	<b>SI</b>
CRF	230 M	09-12	<b>SI</b>
SL	230	97-01	<b>HF</b>
CR	250 R	95-07	<b>RSI</b>
CRE	250	02-07	<b>SI</b>
CRF	250 R	04-22	<b>RSI</b>
CRF	250 X	04-19	<b>SI</b>
XR	250 L	93-97	<b>HF</b>
XR	250 S	96-00	<b>HF</b>
XR	400 R	96-04	<b>SI</b>



Available compounds

HF • SI • RSI

SBS 692

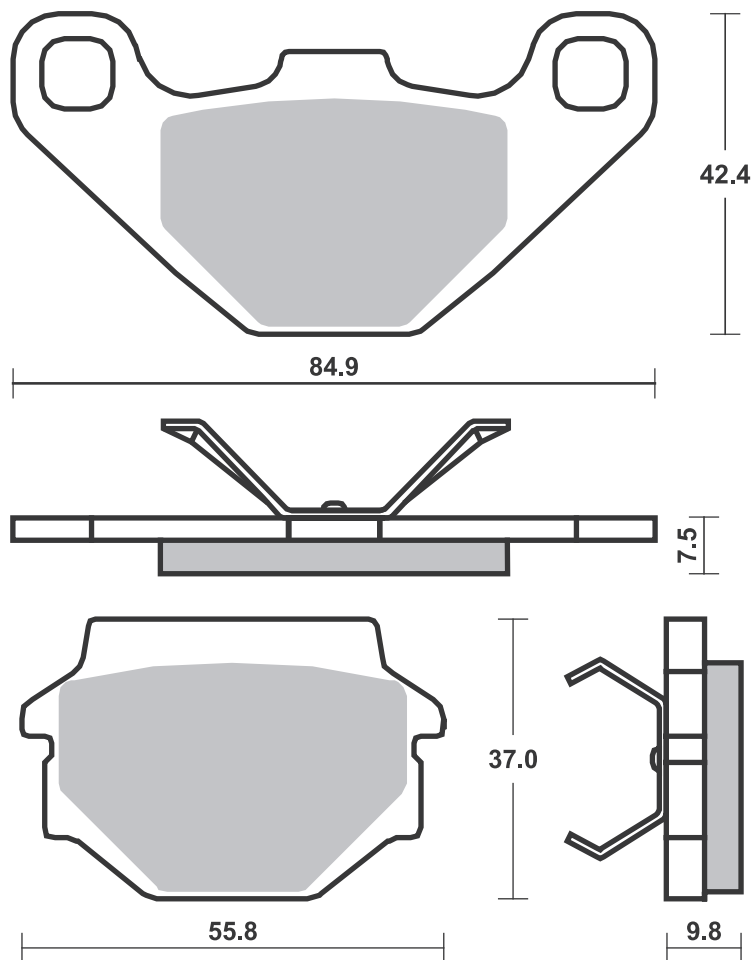

Available compounds

HF • HS • CS • SI • RSI

SBS 694

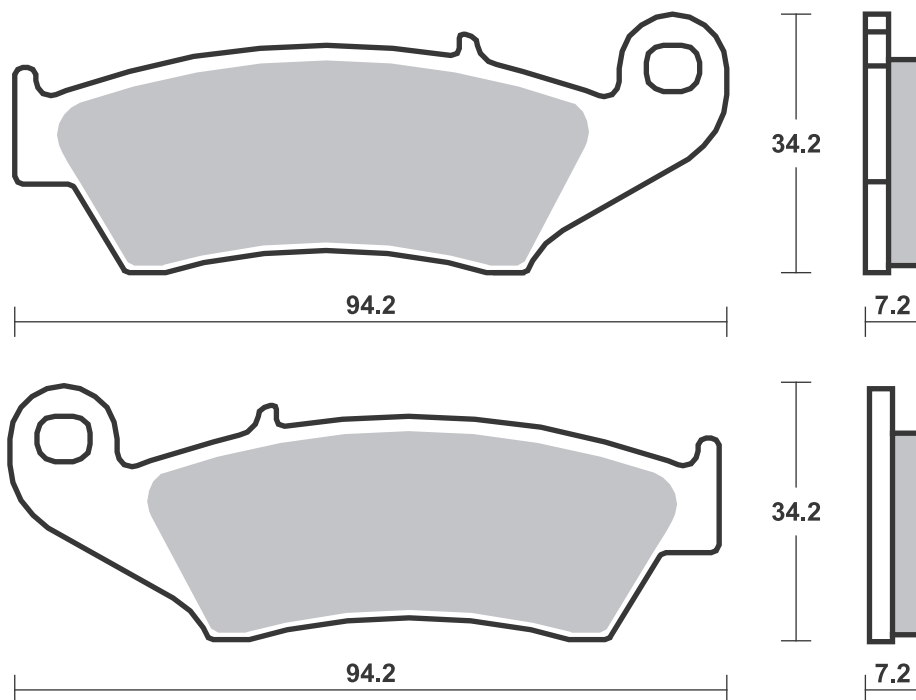

**SBS 694** Recommended compound

<b>HONDA</b>			
XR	440 R	00-03	<b>SI</b>
CRE	450 F	02-06	<b>SI</b>
CRF	450 L	19-21	<b>RSI</b>
CRF	450 R	02-22	<b>RSI</b>
CRF	450 R-S	22-22	<b>RSI</b>
CRF	450 RWE	19-22	<b>RSI</b>
CRF	450 RX	17-22	<b>SI</b>
CRF	450 X	05-22	<b>SI</b>
TRX	450 R	04-09	<b>SI</b>
CR	500 R	95-01	<b>RSI</b>
XR	600 R	93-00	<b>SI</b>
XR	650 L	93-18	<b>HF</b>
XR	650 R	00-11	<b>SI</b>
TRX	700 XX	08-12	<b>SI</b>

<b>KAWASAKI</b>			
KX	125	94-08	<b>RSI</b>
KDX	200	94-99	<b>SI</b>
KDX	220 R	97-05	<b>SI</b>
KLX	250	93-96	<b>SI</b>
KLX	250	98-07	<b>SI</b>
KX	250	94-08	<b>RSI</b>
KX	250	19-22	<b>RSI</b>
KX	250 F	04-18	<b>RSI</b>
KX	250 X	21-22	<b>SI</b>
KLX	300 R	97-07	<b>SI</b>
KLX	400 R	03-04	<b>SI</b>
KLX	400 SR	03-04	<b>HF</b>
KLX	450 R	07-19	<b>SI</b>
KX	450	19-22	<b>RSI</b>
KX	450 F	06-18	<b>RSI</b>
KX	450 X	21-22	<b>SI</b>
KX	500	94-04	<b>RSI</b>
KLX	650	93-96	<b>SI</b>
KLX	650 R	93-95	<b>SI</b>
KLX	650 R D1	96-96	<b>SI</b>

<b>SUZUKI</b>			
RM	125	96-09	<b>RSI</b>
DR-Z	250	01-07	<b>SI</b>
RM	250	96-09	<b>RSI</b>
RMX	250	96-98	<b>RSI</b>



<b>SUZUKI</b>			
RMX	250 X-K1	99-99	<b>SI</b>
RM-Z	250	04-22	<b>RSI</b>
DR	350 V, W, X	97-99	<b>SI</b>
DR-Z	400 S/E	00-12	<b>HF</b>
DR-Z	400 SM	05-10	<b>RSI</b>
RMX	450 Z	10-18	<b>SI</b>
RM-Z	450	05-22	<b>RSI</b>
DR	650 SE T-W	96-99	<b>HF</b>

<b>YAMAHA</b>			
WR	125	98-02	<b>SI</b>
YZ	125	98-07	<b>RSI</b>
WR	250	98-02	<b>SI</b>
WR	250 F	01-13	<b>SI</b>
WR	250 F Efi	15-17	<b>SI</b>
WR	250 R	08-15	<b>HS</b>
YZ	250	98-07	<b>RSI</b>
YZ	250 F	01-06	<b>RSI</b>
WR	400 F	98-00	<b>SI</b>
YZ	400 F	98-98	<b>RSI</b>
YZ	400 F	99-99	<b>RSI</b>
WR	426 F	01-02	<b>SI</b>
YZ	426 F	00-02	<b>RSI</b>
WR	450 F	03-15	<b>SI</b>
YZ	450 F	03-07	<b>RSI</b>

<b>ZERO</b>			
DS	ZF11.4	13-14	<b>HS</b>
DS	ZF8.5	13-14	<b>HS</b>
FX	ZF2.8	13-14	<b>HS</b>
FX	ZF5.7	13-14	<b>HS</b>
MX	ZF2.8	13-13	<b>RSI</b>
MX	ZF5.7	13-13	<b>RSI</b>
S	ZF11.4	13-14	<b>HS</b>
S	ZF8.5	13-14	<b>HS</b>
SR	ZF11.4	14-14	<b>HS</b>
XU	ZF2.8	13-13	<b>HS</b>
XU	ZF5.7	13-13	<b>HS</b>

**SBS 695** Recommended compound

<b>APRILIA</b>			
SXV	450 Van den Bosch Rep.	08-10	<b>RST</b>
SXV	550 Van den Bosch Rep.	08-10	<b>RST</b>

<b>BREMBO RACING CALIPERS</b>			
GP X10.48.13/14, racing			

<b>GALESPEED</b>			
4 Piston Axial Front Caliper, GSFCAR3430AF(Right)/GSFCAL3430AF(Left)			
4 Piston Axial Front Caliper, GSFCAR3430AT(Right)/GSFCAL3430AT(Left)			



<b>GALESPEED</b>			
4 Piston Radial Front Caliper, GSFCAR3430F(Right)/GSFCAL3430F(Left)			
4 Piston Radial Front Caliper, GSFCAR3430T(Right)/GSFCAL3430T(Left)			

Available compounds

HF • HS • CS • SI • RSI

SBS 694

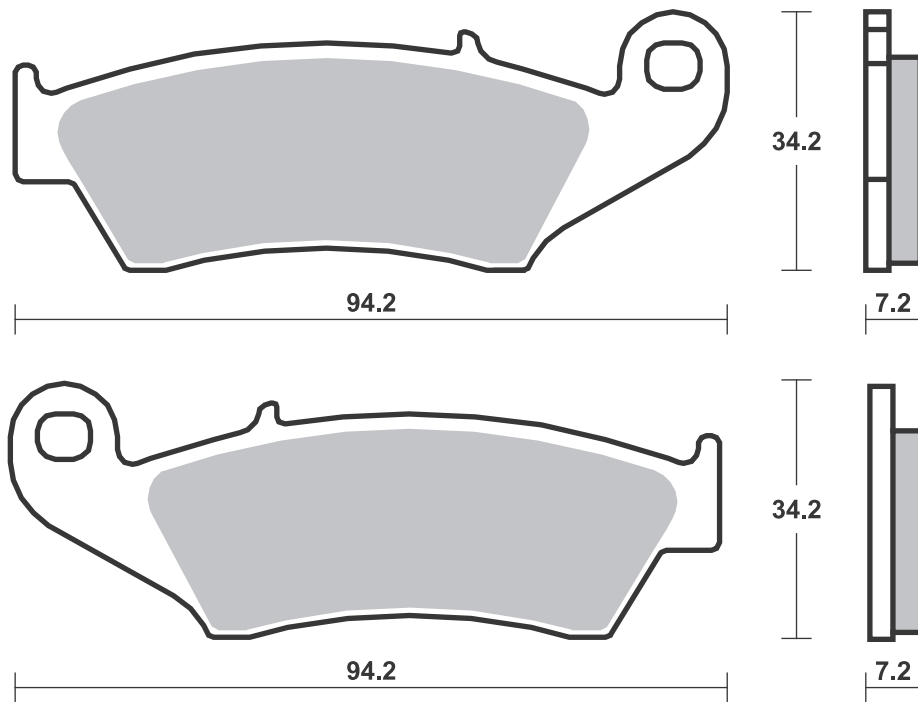

Available compounds

DC • RST • DS-1 • DS-2

SBS 695

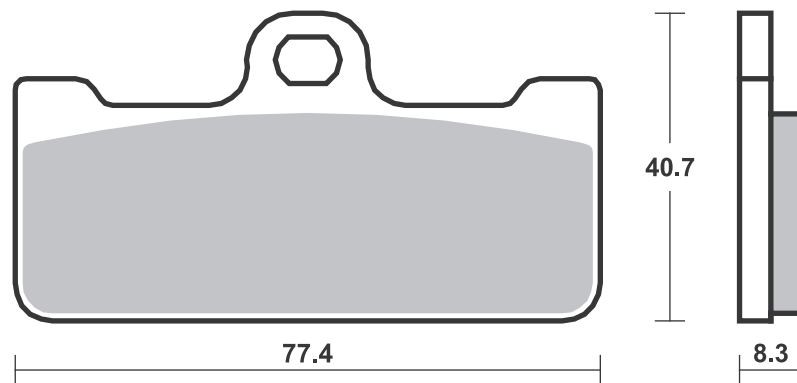



Available compounds

HF

SBS 698

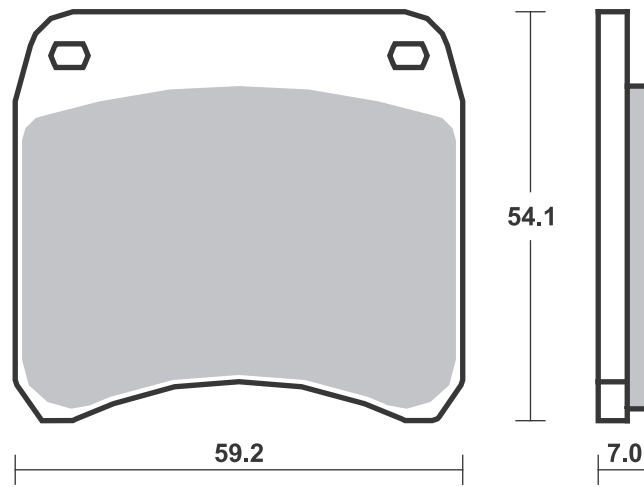

Available compounds

HF

SBS 699

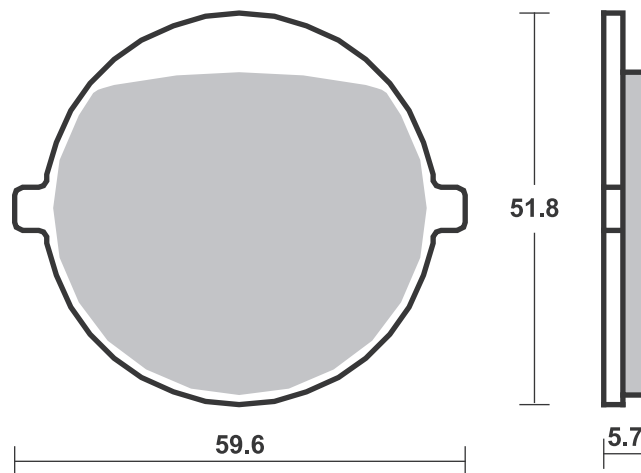



Available compounds

HF • HS • SP • DC • RST • DS-1 • DS-2

SBS 700

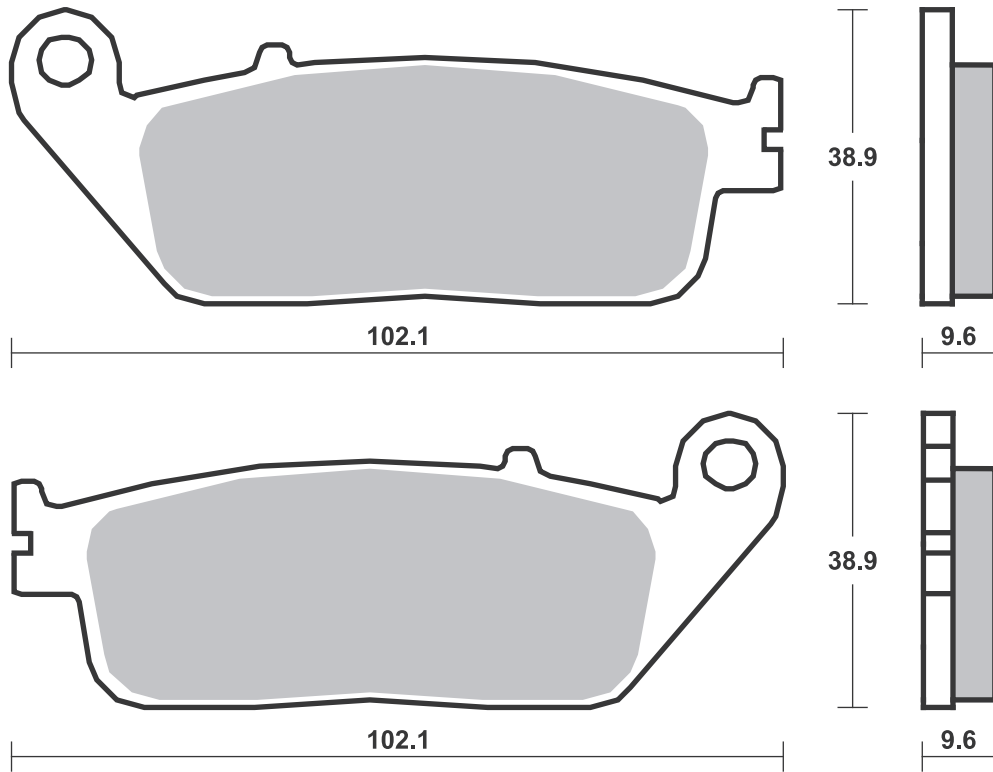

Available compounds

HF • LS

SBS 701

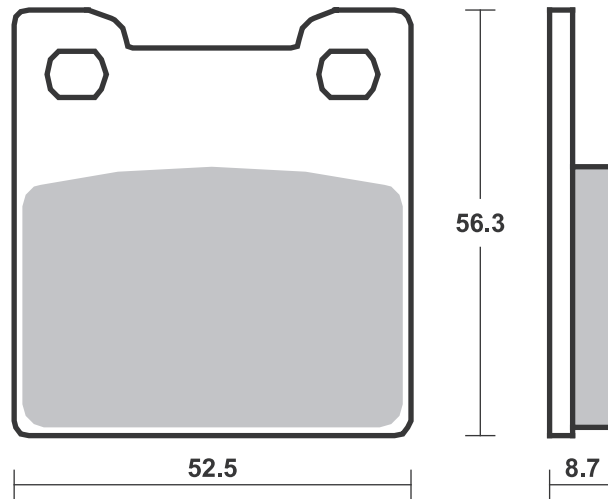

**SBS 702** Recommended compound



**KAWASAKI**

KLX	125 L	03-06	<b>SI</b>
-----	-------	-------	-----------

**SUZUKI**

RM	80	96-01	<b>RSI</b>
RM	85	02-04	<b>RSI</b>
DR-Z	125 L	03-20	<b>SI</b>

**SBS 703** Recommended compound



**BMW**

R	850 C	99-01	<b>HS</b>
R	850 GS	99-07	<b>HS</b>
R	850 R	96-02	<b>HS</b>
R	850 RT	96-01	<b>HS</b>
R	1100 GS	94-01	<b>HS</b>
R	1100 R Cast wheels	99-01	<b>HS</b>
R	1100 R Spoke wheels	99-06	<b>HS</b>
R	1100 RT Cast wheels	95-01	<b>HS</b>
R	1100 RT Spoke wheels	95-01	<b>HS</b>
R	1100 S	99-00	<b>HS</b>
R1100	1100 RS	94-01	<b>HS</b>
R	1150 GS	00-01	<b>HS</b>
K	1200 LT	99-00	<b>HS</b>
K	1200 RS	97-00	<b>HS</b>
R	1200 C	98-02	<b>HS</b>

Brake Pad 1:1 Drawings, Compounds, Fitments



Available compounds

HF • CS • SI • RSI

SBS 702

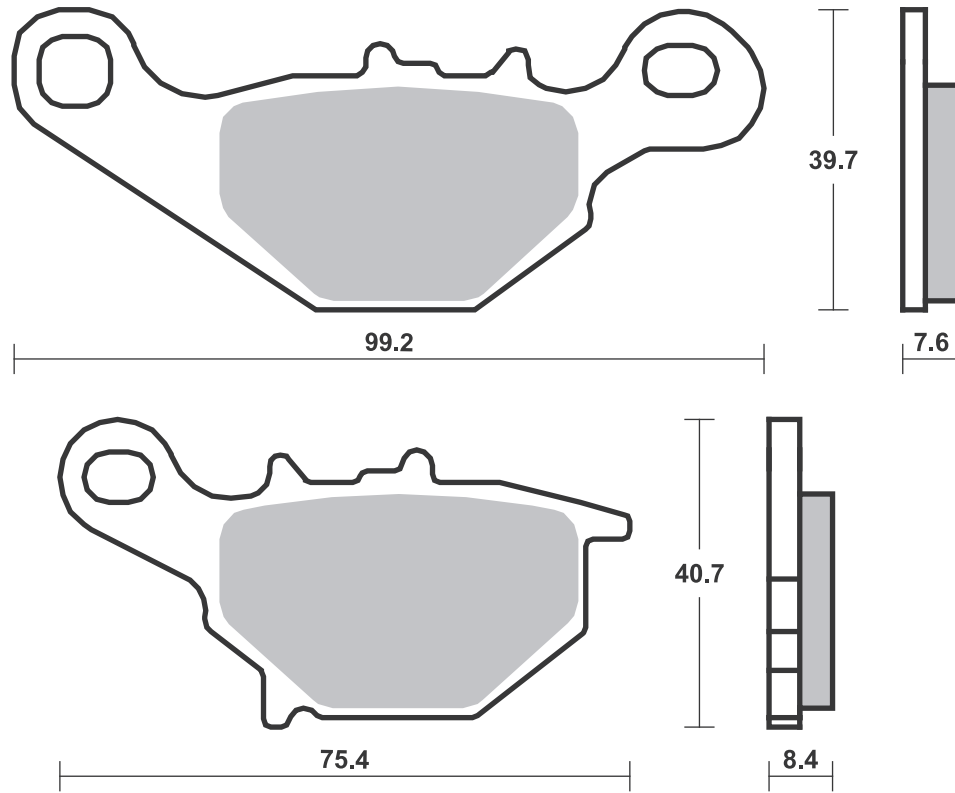

Available compounds

HF • HS

SBS 703

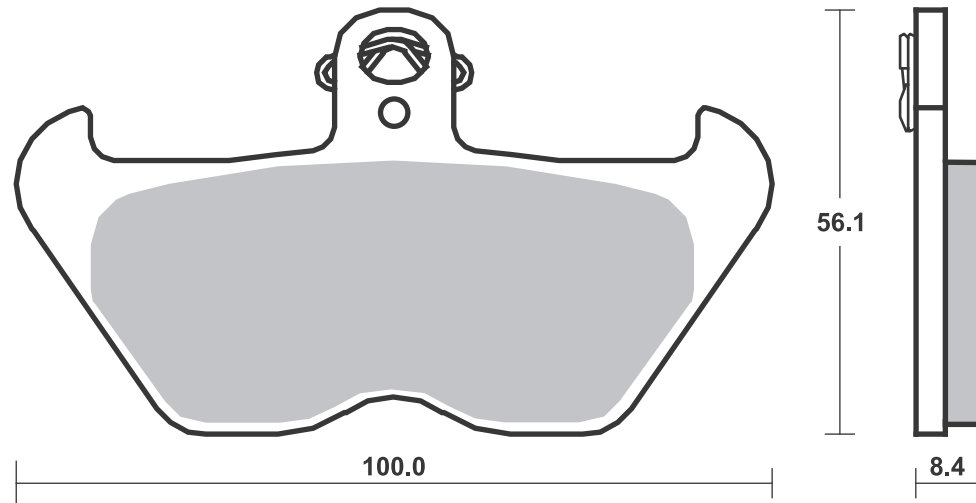

# Applications

## SBS 704 Recommended compound



KAWASAKI			
400 Ninja R	11-11	HS	
650 R Ninja	06-08	HS	
KLE 650 Versys	07-14	HS	
W 650	99-05	HF	
Z 750	04-06	HS	
Z 750 S	05-06	HS	
ZR 750 Zephyr	96-97	HS	
ZR-7S 750	01-04	HS	LS
ZR-7S 750	01-04	HS	LS
VN 800 Vulcan Drifter	99-03		LS
W 800	11-16	HS	
W 800 Cafe	19-19	HS	
W 800 Street	19-19	HS	
KLV 1000	04-07	HS	
KZ 1000 Police	02-03	HS	
GPZ 1100 (ZX 1100)	95-99	HS	
VN 1500 Vulcan Drifter	99-02		LS
VN 1500 Vulcan Nomad	98-01	HS	
VN 1500 Vulcan Nomad			
Fi	00-04	HS	
VN 1600 Nomad	05-05	HS	
VN 1600 Vulcan Classic	03-08	HS	
VN 1700 Voyager			
Vaquero	09-14	HS	
VN 1700 Vulcan Classic	09-14	HS	
VN 1700 Vulcan Nomad	09-16	HS	



SUZUKI			
RV 125 VanVan	03-18	HF	
RV 200 VanVan	16-19	HF	
GS 500 F	04-08	HS	
GSF 600 Bandit /			
S Bandit	00-04	HS	
GSX 600 FW	98-04	HS	
DL 650 V-Strom	04-20	HS	
DL 650 V-Strom XT	15-20	HS	
GSF 650 Bandit /			
S Bandit	05-05	HS	
GSF 650 Bandit /			
S Bandit ABS	06-06	HS	
SFV 650 Gladius	09-16	HS	
SV 650	16-18	HS	
SV 650 ,S	99-12	HS	
SV 650 ,S	03-12	HS	
SV 650 X	18-18	HS	
GSR 750	11-16	HS	
GSX 750	98-08	HS	
GSX 750 FW	98-02	HS	
GSX-S 750	15-16	HS	
GSX-S 750 Z	15-16	HS	
C50 800 Boulevard	05-18	HS	
M50 800 Boulevard	05-18	HS	
VL 800 Intruder			
LC Volusia	01-04	HS	
VZ 800 Marauder	97-04	HS	
DL 1000 V-Strom	02-13	HS	



SUZUKI			
GSX 1100 G	96-98	HS	
C90 1500 Boulevard	05-18	HS	
M90 1500	09-18	HS	
VL 1500 Intruder LC	02-02	HS	

## SBS 705 Recommended compound



KAWASAKI			
400 Ninja R	11-11	HS	
650 R Ninja	06-08	HS	
KLE 650 Versys	07-14	HS	
KLR 650	95-04	HS	
Z 750	04-06	HS	
Z 750 S	05-06	HS	
ZR 750 Zephyr	96-97	HS	
ZR-7S 750	01-04	HS	
VN 800 Vulcan Classic	96-06	HS	
VN 800 Vulcan Drifter	99-03	HS	
VN 900 Vulcan Classic	06-16	HS	
VN 900 Vulcan Classic			
SE	11-16	HS	
VN 900 Vulcan			
Custom	07-16	HS	
KLV 1000	04-07	HS	
KZ 1000 Police	02-03	HS	
GPZ 1100 (ZX 1100)	95-99	HS	
VN 1500 Vulcan Classic	97-99	HS	
VN 1500 Vulcan Classic			
Fi	00-04	HS	
VN 1500 Vulcan Drifter	99-02	HS	
VN 1500 Vulcan Nomad	98-01	HS	
VN 1500 Vulcan Nomad			
Fi	00-04	HS	
VN 1600 Nomad	05-05	HS	
VN 1600 Vulcan Classic	03-08	HS	
VN 1700 Voyager			
Vaquero	09-14	HS	
VN 1700 Vulcan Classic	09-14	HS	
VN 1700 Vulcan Nomad	09-16	HS	



SUZUKI			
TU 250 X	09-19	HF	
GSF 600 Bandit /			
S Bandit	00-04	HS	
GSX 600 FW	98-04	HS	
DL 650 V-Strom	04-20	HS	
DL 650 V-Strom XT	15-20	HS	
GSF 650 Bandit /			
S Bandit	05-05	HS	
GSF 650 Bandit /			
S Bandit ABS	06-06	HS	
SFV 650 Gladius	09-16	HS	
SV 650	16-18	HS	
SV 650 ,S	99-12	HS	
SV 650 ,S	03-12	HS	
SV 650 ,S ABS	07-18	HS	
SV 650 X	18-18	HS	
GSR 750	11-16	HS	
GSX 750	98-08	HS	
GSX 750 FW	98-02	HS	
GSX-S 750	15-16	HS	
GSX-S 750 Z	15-16	HS	
DL 1000 V-Strom	02-13	HS	
GSX 1100 G	96-98	HS	
C90 1500 Boulevard	05-18	HS	
M90 1500	09-18	HS	
VL 1500 Intruder LC	02-02	HS	

Available compounds

HF • HS • LS • SP • RST

SBS 704

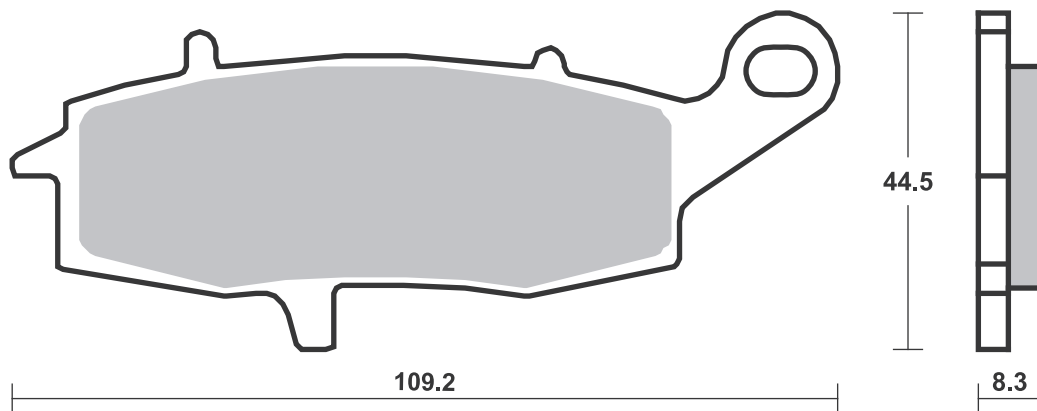
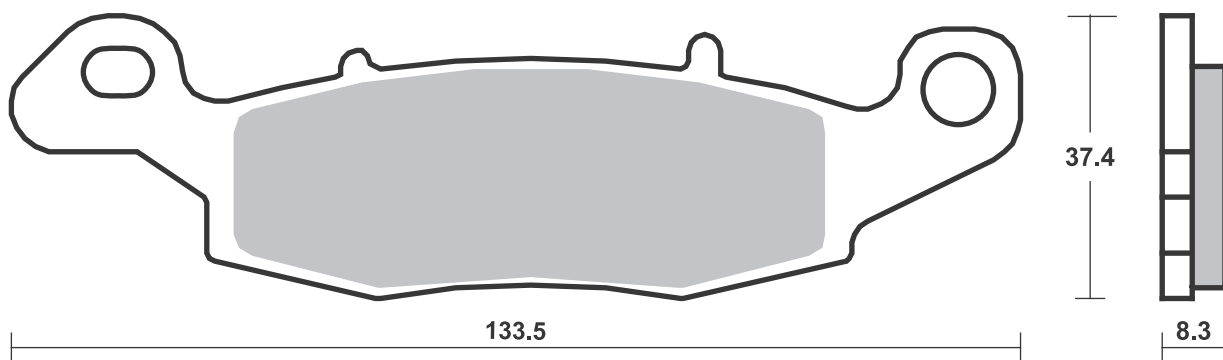

Available compounds

HF • HS • SP • RST

SBS 705

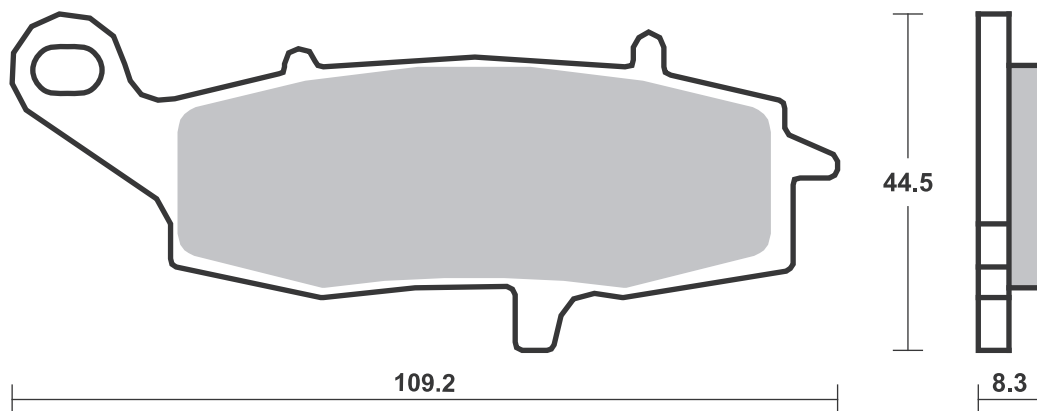
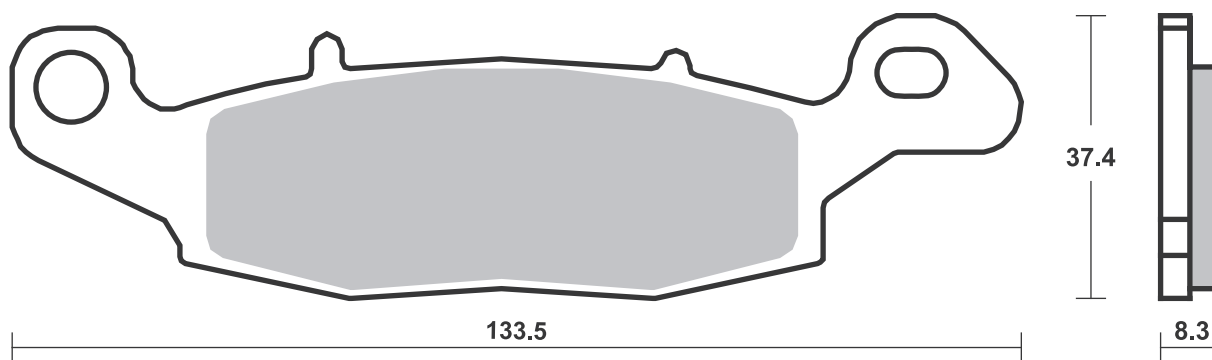



<b>APRILIA</b>			
RS	250 Pista	04-04	<b>HF</b>
	650 Pegaso Strada	05-09	<b>HS</b>
	750 Dorsoduro		
	Factory	12-13	<b>HS</b>
SMV	750 Dorsoduro	08-08	<b>HS</b>
	1000 Blue Marlin	02-02	<b>HS</b>
RST	1000 Futura	01-03	<b>HS</b>
RSV	1000	97-01	<b>HS</b>
RSV	1000 Falco SL, R	00-04	<b>HS</b>
RSV	1000 R	00-00	<b>HS</b>
RSV	1000 SP	00-00	<b>HS</b>
RSV	1000 Tuono Fighter	03-05	<b>HS</b>
RSV	1000 Tuono R, ABS	04-12	<b>HS</b>
RSV	1000 Tuono V4 R	11-13	<b>HS</b>
	1200 Dorsoduro,		
	ABS	11-14	<b>HS</b>

<b>BENELLI</b>			
	500 Leoncino	16-17	<b>HS</b>
TRK	502	16-17	<b>HS</b>
BN	600	12-13	<b>HS</b>
	756 Cue	10-12	<b>HS</b>
	899 Trek	07-12	<b>HS</b>
TnT	899	07-15	<b>HS</b>
	900 Tornado 3	00-06	<b>HS</b>
TnT	1100	04-04	<b>HS</b>
TnT	1130	05-14	<b>HS</b>
TnT	1130 Trek	06-12	<b>SP</b>
TnT	1130 Trek		
	Amazonas	07-15	<b>SP</b>

<b>BIMOTA</b>			
DB4	900	99-00	<b>HS</b>
SB8	1000 R	98-00	<b>HS</b>
SB8K	1000	06-06	<b>HS</b>

<b>BMW</b>			
G	650 Xmoto	06-07	<b>HS</b>
F	800 GT	13-20	<b>HS</b>
F	800 R	09-14	<b>HS</b>
F	800 S	06-10	<b>HS</b>
F	800 ST	06-12	<b>HS</b>
F	800 ST Touring	11-12	<b>HS</b>
R	1200 Nine-T Pure	17-22	<b>HS</b>
R	1200 Nine-T Racer	17-20	<b>HS</b>
R	1200 Nine-T		
	Scrambler	16-22	<b>HS</b>
R	1200 Nine-T		
	Urban GS	17-22	<b>SP</b>

<b>BRAKING</b>			
Street, Supermotard			

<b>BRAMMO</b>			
	Empulse	14-16	<b>H.HS</b>

<b>BREMBO RACING CALIPERS</b>			
100 mm Motard Radial			
XA78910, P4 30/34			
100 mm Radial 220A16810,			
P4 30/34			
100 mm Radial 220A80310,			
P4 30/34			
108 mm Motard Radial			
XA69510, P4 30/34			
108 mm Radial 220A01610,			
P4 30/34			



<b>BREMBO RACING CALIPERS</b>			
108 mm Radial 220A80210,			
P4 30/34			
Goldline two pin 20.6800,			
road			
Radial 220A16820, P4 30/34			

<b>CAGIVA</b>			
	650 Raptor	01-08	<b>HS</b>
	650 V-Raptor	01-08	<b>HS</b>
	1000 Raptor	00-08	<b>HS</b>
	1000 V-Raptor	00-08	<b>HS</b>
	1000 Xtra Raptor	02-06	<b>HS</b>

<b>CF MOTO</b>			
	700 CL-X	22-22	<b>SP</b>
	800 MT Sport	22-22	<b>SP</b>
	800 MT Touring	22-22	<b>SP</b>

<b>DUCATI</b>			
	400 Monster		
	(Japan)	01-06	<b>HS</b>
	600 Monster	00-01	<b>HS</b>
	620 Monster		
	Dark i.e.	02-06	<b>HS</b>
	620 Monster i.e.,		
	s i.e.	02-06	<b>HS</b>
	620 Multistrada		
	Dark	05-06	<b>HS</b>
	620 Sport	03-06	<b>HS</b>
	696 Monster	08-12	<b>HS</b>
	748 , S	99-02	<b>HS</b>
	748 R	00-00	<b>HS</b>
	748 SPS	98-99	<b>HS</b>
	750 Monster	00-01	<b>HS</b>
	750 Monster i.e.	02-02	<b>HS</b>
	750 Sport	00-02	<b>HS</b>
	750 Super Sport	00-02	<b>HS</b>
	795 Monster	12-12	<b>HS</b>
	796 Hypermotard	10-12	<b>HS</b>
	796 Monster	11-14	<b>HS</b>
	796 Monster ABS	11-14	<b>HS</b>
	800 Monster Dark		
	i.e., s i.e.	03-07	<b>HS</b>
	800 Monster i.e.,		
	s i.e.	03-07	<b>HS</b>
	800 Sport	03-06	<b>HS</b>
	800 Supersport	03-06	<b>HS</b>
	848	08-10	<b>HS</b>
	848 Streetfighter	12-15	<b>HS</b>
	900 Monster	00-01	<b>HS</b>
	900 Monster i.e.	02-02	<b>HS</b>
	900 Super Sport	98-02	<b>HS</b>
MH	900	00-01	<b>HS</b>
	916 Monster S4	01-03	<b>HS</b>
	916 Sport		
	Touring 4	99-01	<b>HS</b>
	916 SPS	97-98	<b>HS</b>
	944 Sport Touring	98-03	<b>HS</b>
	944 ST2	97-03	<b>HS</b>
	992 ST3	04-07	<b>HS</b>
	992 ST3s ABS	06-07	<b>HS</b>
	996 , SPS	99-01	<b>HS</b>
	996 Monster S4R	04-06	<b>HS</b>
	996 S	01-01	<b>HS</b>
	996 ST4s	02-06	<b>HS</b>
	996 ST4s ABS	03-06	<b>HS</b>
	998 , S	02-04	<b>HS</b>



<b>DUCATI</b>			
	1000 Monster Dark		
	i.e., s i.e.	03-06	<b>HS</b>
	1000 Monster i.e.,		
	s i.e.	03-06	<b>HS</b>
	1000 Monster S2R	06-07	<b>HS</b>
	1000 Multistrada	07-07	<b>HS</b>
	1000 Multistrada DS	03-06	<b>HS</b>
	1000 Multistrada S		
	DS	05-06	<b>HS</b>
	1000 Supersport		
	DS	03-06	<b>HS</b>
	1100 Hypermotard	07-09	<b>HS</b>
	1100 Hypermotard		
	EVO	10-12	<b>HS</b>
	1100 Monster	09-13	<b>HS</b>
	1100 Monster ABS	09-10	<b>HS</b>
	1100 Monster EVO	11-13	<b>HS</b>
	1100 Monster EVO		
	ABS	11-13	<b>HS</b>
	1100 Monster S	09-13	<b>HS</b>
	1100 Monster S		
	ABS	09-10	<b>HS</b>
	1100 Multistrada	07-09	<b>HS</b>
	1100 Multistrada S	07-09	<b>HS</b>
	1200 Multistrada	10-14	<b>SP</b>
	1200 Multistrada S		
	GT	12-14	<b>SP</b>
	1200 Multistrada S		
	Pikes Peak	11-14	<b>SP</b>
	1200 Multistrada S		
	Sport	10-14	<b>SP</b>
	1200 Multistrada S		
	Touring	10-14	<b>SP</b>

<b>HUSQVARNA</b>			
	570 Nox	01-03	<b>HF</b>
LT	610	00-02	<b>HF</b>
SM	610 Super		
	Motard, S	98-00	<b>HF</b>
SMR	630	04-08	<b>RST</b>
	701 Svartpilen	18-19	<b>HS</b>
	701 Vitpilen	18-20	<b>HS</b>
	900 Nuda	12-13	<b>HS</b>
	901 Norden	22-22	<b>SP</b>

<b>KTM</b>			
SMC	625	05-06	<b>HF</b>
	640 Duke	03-06	<b>HF</b>
LC4	640 Supermoto	04-04	<b>HF</b>
SMC	660 Supermoto	04-07	<b>HF</b>
	690 Duke ABS	12-19	<b>HS</b>
	790 Adventure	19-20	<b>HS</b>
	790 Adventure R	19-20	<b>HS</b>
	790 Adventure R		
	Rally	20-20	<b>HS</b>
	790 Duke	18-20	<b>HS</b>
	890 Adventure R	21-21	<b>SP</b>
	1050 Adventure	15-16	<b>SP</b>
	1090 Super		
	Adventure	17-19	<b>SP</b>
	1090 Super		
	Adventure R	17-20	<b>SP</b>
	1190 Adventure	13-16	<b>SP</b>
	1290 Super		
	Adventure	15-16	<b>SP</b>
	1290 Super		
	Adventure R	17-20	<b>SP</b>

Available compounds

HF • HS • SP • DC • RST • DS-1 • DS-2 •

SBS 706

H.HF • H.CT • H.HS

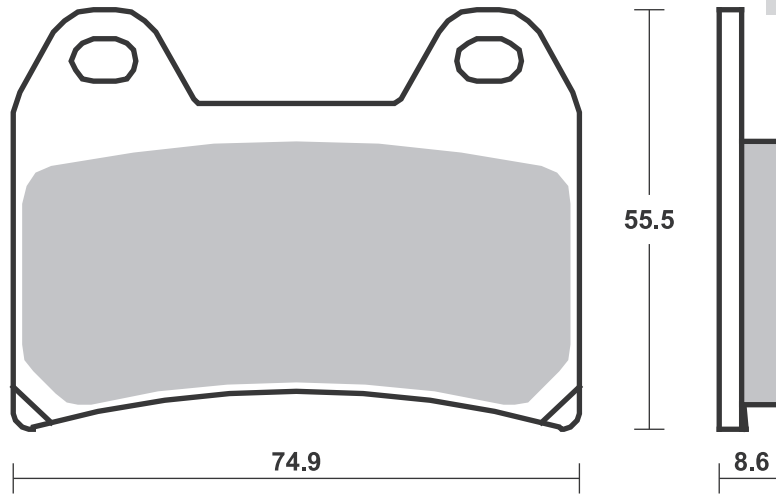



<b>KTM</b>			
1290 Super			
Adventure S	17-20	<b>SP</b>	
1290 Super			
Adventure T	17-19	<b>SP</b>	

**MOTO-GUZZI**

750 Breva	03-09	<b>HS</b>	
750 Nevada			
Classic ie	06-11	<b>HF</b>	
750 Nevada,			
Nevada Club	03-16	<b>HF</b>	
V7 750 Cafe Classic	10-13	<b>HS</b>	
V7 750 Classic	09-12	<b>HS</b>	
V7 750 Clubman			
Racer	10-10	<b>HS</b>	
V7 750 Racer	11-14	<b>HS</b>	
V7 750 Stone	12-14	<b>HS</b>	
V7 II 750 Racer	15-16	<b>HS</b>	
V7 II 750 Scrambler	16-16	<b>HS</b>	
V7 II 750 Special	15-16	<b>HS</b>	
V7 II 750 Stone	15-16	<b>HS</b>	
V7 II 750 Stornello	16-16	<b>HS</b>	
V7 II 750 Stornello Ltd.			
Edition	17-18	<b>HS</b>	
V7 III 750 Anniversario	17-18	<b>HS</b>	
V7 III 750 Carbon	18-19	<b>HS</b>	
V7 III 750 Euro 4	17-19	<b>HS</b>	
V7 III 750 Limited	19-19	<b>HS</b>	
V7 III 750 Milano	18-20	<b>HS</b>	
V7 III 750 Racer	17-20	<b>HS</b>	
V7 III 750 Rough	18-20	<b>HS</b>	
V7 III 750 Special	17-19	<b>HS</b>	
V7 III 750 Stone	17-20	<b>HS</b>	
850 Breva	06-09	<b>HS</b>	
850 V7 Special	22-22	<b>SP</b>	
850 V7 Stone	22-22	<b>SP</b>	
850 V7 Stone Fast			
Endurance	22-22	<b>SP</b>	
V85 850 TT	19-19	<b>HS</b>	
V85 850 TT Guardia			
d'Onore	22-22	<b>SP</b>	
V85 850 TT travel	20-20	<b>HS</b>	
V9 850 Bobber	16-17	<b>HS</b>	
V9 850 Bobber			
Sports	19-20	<b>HS</b>	
V9 850 Roamer	16-17	<b>HS</b>	
V9 850 X-Track	17-17	<b>HS</b>	
940 Custom	07-07	<b>HS</b>	
1100 California EV	06-06	<b>HS</b>	
1100 California EV			
Touring	06-06	<b>HS</b>	
1100 California			
Jackal	01-06	<b>HS</b>	
1100 California			
Jackal Basic	01-06	<b>HS</b>	
1100 California			
Special	01-01	<b>HS</b>	
1100 California			
Special Sport			
Alloy	02-06	<b>HS</b>	
1100 California			
Stone Metal	02-03	<b>HS</b>	
1100 California			
Stone,			
Stone Touring	02-05	<b>HS</b>	
1100 California			
Titanium	03-05	<b>HS</b>	



<b>MOTO-GUZZI</b>			
1100 California			
Vintage	06-13	<b>HS</b>	
1100 Griso	05-10	<b>HS</b>	
EV 1100 California, 80,			
Touring	01-01	<b>HS</b>	
V 1100 Breva	04-04	<b>HS</b>	
V 1100 Breva, ABS	05-07	<b>HS</b>	
V11 1100 , Scura,			
Sport Scura	02-05	<b>HS</b>	
V11 1100 Lemans,			
Lemans Tenni,			
Lemans			
Rosso			
Corsa	01-06	<b>HS</b>	
V11 1100 Sport Rosso			
Mandell	01-06	<b>HS</b>	
V11 1100 Sport,			
Sport Naked	01-05	<b>HS</b>	
1200 Griso 8V	07-13	<b>HS</b>	
1200 Griso 8V SE	18-18	<b>HS</b>	
1200 Norge	06-14	<b>HS</b>	
1200 Norge GT 8V	10-13	<b>HS</b>	
1200 Sport	07-08	<b>HS</b>	
1200 Sport 4V	09-11	<b>HS</b>	
1200 Sport 8V	12-13	<b>HS</b>	
1200 Sport 8V SE	12-15	<b>HS</b>	
1200 Stelvio	08-11	<b>SP</b>	
1200 Stelvio 8V SE	12-16	<b>SP</b>	
1200 Stelvio NTX	09-11	<b>SP</b>	
V 1200 Breva	08-13	<b>HS</b>	
1400 Audace	15-17	<b>HS</b>	
1400 California			
Custom	13-15	<b>HS</b>	
1400 California			
Touring	13-15	<b>HS</b>	
1400 California			
Touring SE	16-17	<b>HS</b>	
1400 Eldorado	15-17	<b>HS</b>	
MGX-21 1400 Flying			
Fortress	15-17	<b>HS</b>	

**MOTO-MORINI**

1200 11 1/2	18-18	<b>HS</b>	
1200 9 1/2	06-09	<b>HS</b>	
1200 Corsaro	06-13	<b>HS</b>	
1200 Sport	08-13	<b>HS</b>	

**MOTUS**

MST 1650	14-17	<b>HS</b>	
----------	-------	-----------	--

**MV AGUSTA**

675 Brutale	12-15	<b>HS</b>	
F3 675	11-14	<b>HS</b>	
800 Brutale	13-20	<b>HS</b>	
800 Brutale			
Dragster	15-19	<b>HS</b>	
800 Brutale			
Dragster RC	17-20	<b>HS</b>	
800 Brutale			
Dragster RR	15-19	<b>HS</b>	
800 Brutale			
Dragster			
RR LH44	18-20	<b>HS</b>	
800 Brutale			
Dragster			
RR Pirelli	18-20	<b>HS</b>	
800 Brutale RC	18-20	<b>HS</b>	



<b>MV AGUSTA</b>			
800 Brutale RR	16-20	<b>HS</b>	
800 RVS#1	18-20	<b>HS</b>	
920 Brutale	12-14	<b>HS</b>	
989 Brutale R	09-09	<b>HS</b>	
990 Brutale R	10-11	<b>HS</b>	
1090 Brutale R	12-15	<b>HS</b>	

**MZ**

1000 (MUZ) S	01-02	<b>HS</b>	
--------------	-------	-----------	--

**NORTON**

961 Commando SE	10-11	<b>HS</b>	
961 Commando SF			
Sport	11-15	<b>HS</b>	

**VICTORY**

Empulse TT	16-17	<b>H.HS</b>	
1500 Kingpin	04-05	<b>H.HS</b>	
1500 Touring Cruiser	03-06	<b>H.HS</b>	
1500 V92C Cruiser	98-02	<b>H.HS</b>	
1500 V92C Deluxe	01-02	<b>H.HS</b>	
1500 V92SC Sport			
Cruiser	00-02	<b>H.HS</b>	
1500 Vegas	03-05	<b>H.HS</b>	
1500 Vegas 8-Ball	05-05	<b>H.HS</b>	
1634 Hammer	05-07	<b>H.HS</b>	
1634 Hammer S	06-08	<b>H.HS</b>	
1634 Kingpin	06-07	<b>H.HS</b>	
1634 Kingpin Tour	06-07	<b>H.HS</b>	
1634 Vegas	06-07	<b>H.HS</b>	
1634 Vegas 8-Ball	06-07	<b>H.HS</b>	
1634 Vegas Jackpot	06-07	<b>H.HS</b>	

**YAMAHA**

XT 660 X	04-13	<b>HS</b>	
----------	-------	-----------	--

**ZERO**

DSRBF ZF14.4	19-21	<b>HS</b>	
SR/F ZF14.4	19-21	<b>HS</b>	
SR/S ZF14.4	19-21	<b>HS</b>	

Available compounds

HF • HS • SP • DC • RST • DS-1 • DS-2 •

SBS 706

H.HF • H.CT • H.HS

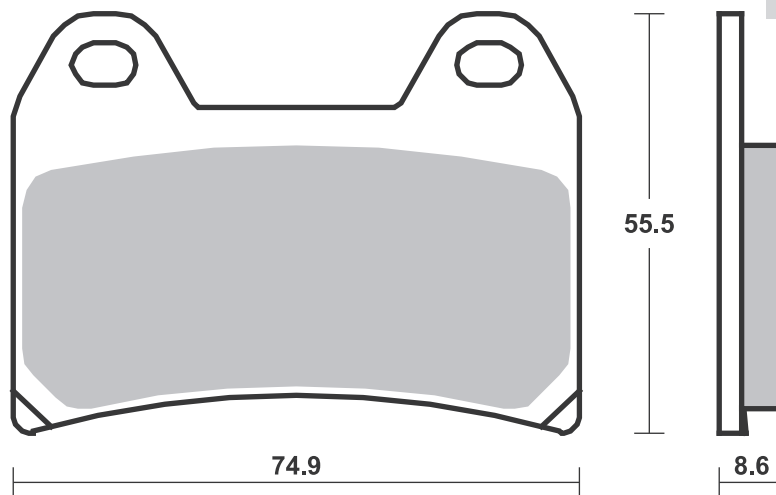

**SBS 707** Recommended compound



**A.P. RACING CALIPERS**

6 Piston 4466/4477 Series

**PFM**

6 Piston Racing Caliper

**SBS 708** Recommended compound



**SYM**

	125 Attila	95- 02	<b>HF</b>
H01	150	95- 00	<b>HF</b>

**ZERO**

DS	ZF6.0	10- 12	<b>HF</b>
DS	ZF9.0	10- 12	<b>HF</b>
MX		10- 12	<b>HF</b>
S	ZF6.0	10- 12	<b>HF</b>
X		10- 12	<b>HF</b>
XU		11- 12	<b>HF</b>

Brake Pad 1:1 Drawings,  
Compounds, Fitments



Available compounds

**RST • DS-1 • RQ**

**SBS 707**

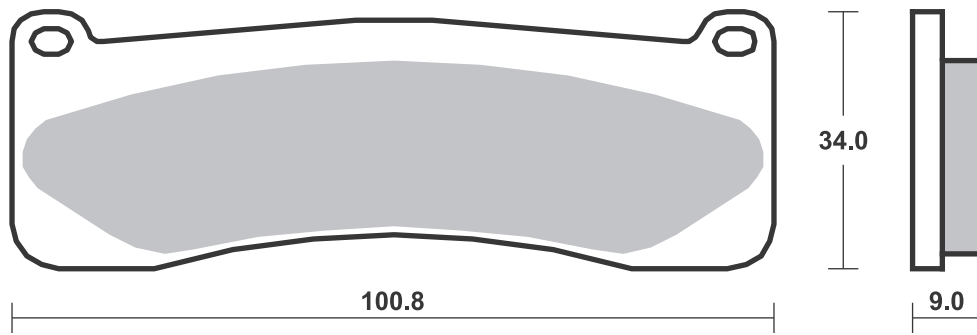

Available compounds

**HF**

**SBS 708**

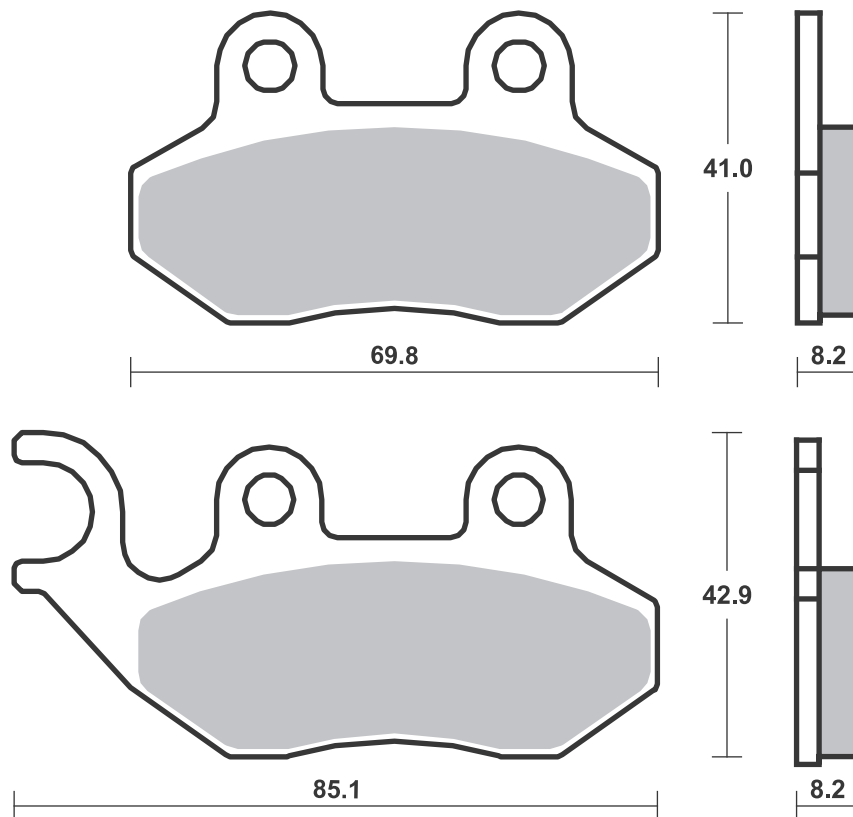



Available compounds

**HF • LS • SI • RSI**

**SBS 709**

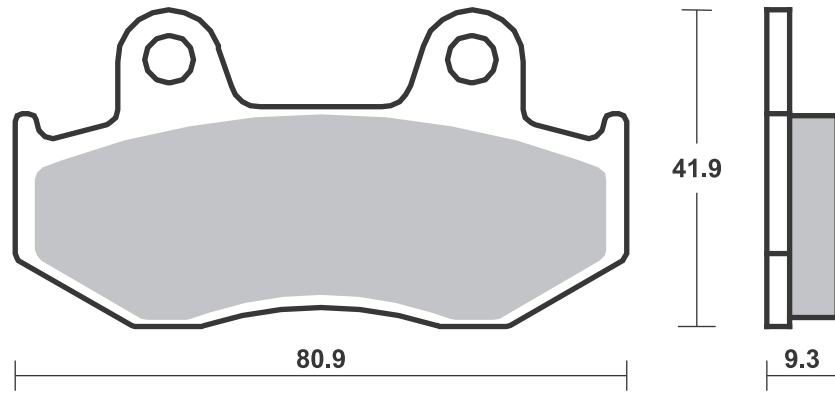

Available compounds

**DC • RST • DS-1 • DS-2**

**SBS 711**

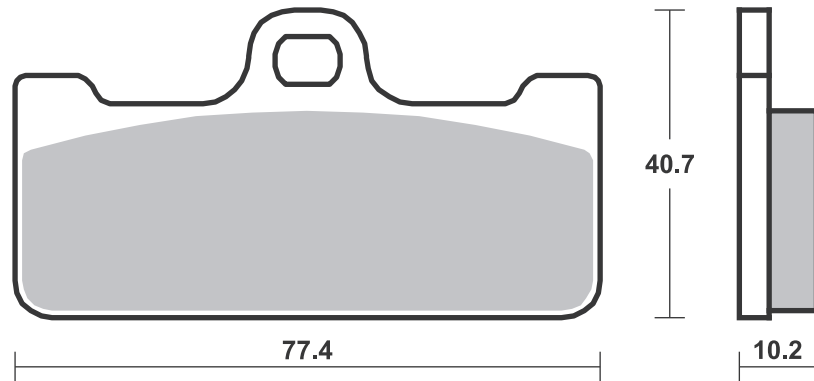



Available compounds

HF

SBS 713

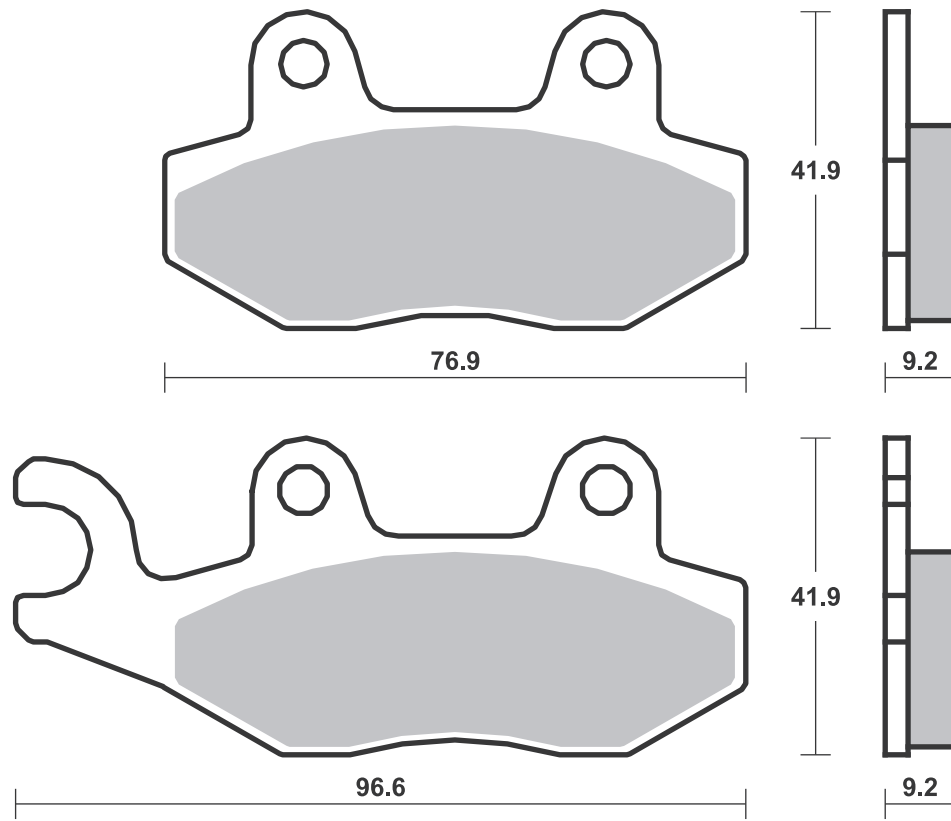

Available compounds

HF • HS

SBS 714

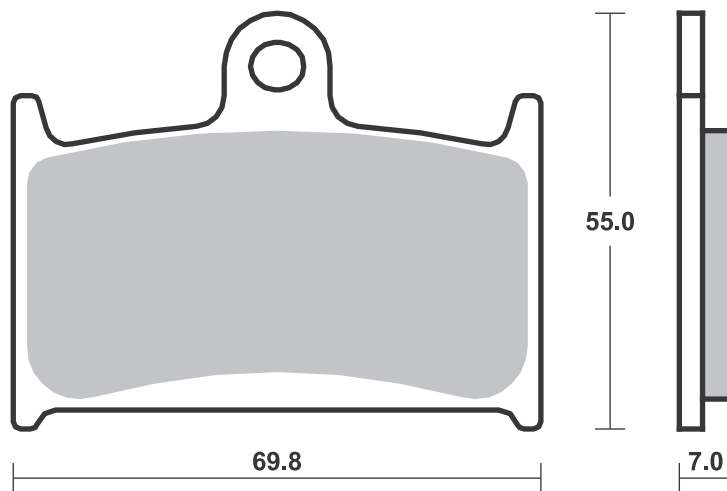

# Applications

## SBS 715 Recommended compound



<b>HARLEY DAVIDSON</b>			
XL	883 L Super Low	14- 18	<b>H.LS</b>
XL	883 N Iron	14- 18	<b>H.LS</b>
XL	883 R Roadster	14- 15	<b>H.LS</b>
XL	1200 C, CA, CB, CP Custom	14- 19	<b>H.LS</b>
XL	1200 CX	17- 17	<b>H.LS</b>
XL	1200 Iron	18- 20	<b>H.LS</b>
XL	1200 Roadster	18- 20	<b>H.LS</b>
XL	1200 T Super Low	15- 17	<b>H.LS</b>
XL	1200 V Seventy-Two	14- 16	<b>H.LS</b>
XL	1200 X Forty-Eight	14- 18	<b>H.LS</b>
XL	1200 X Forty-Eight Spec.	19- 20	<b>H.LS</b>



<b>HONDA</b>			
VT	750 C2S ABS	13- 14	<b>LS</b>
VT	750 CS ABS	13- 14	<b>LS</b>
VT	750 Shadow Aero	13- 18	<b>LS</b>
CB	1300 R	02- 04	<b>LS</b>
<b>KAWASAKI</b>			
ZX-7RR	750 Ninja	96- 02	<b>LS</b>
ZG	1400 Concours	07- 10	<b>LS</b>
ZX-14R	1400 Ninja	06- 15	<b>LS</b>
ZX-14R	1400 Ninja ABS	07- 15	<b>LS</b>
ZX-14R	1400 SE	16- 18	<b>LS</b>
<b>MZ</b>			
	1000 (MUZ) S	03- 10	<b>LS</b>
	1000 (MUZ) SF	05- 10	<b>LS</b>



<b>MZ</b>			
	1000 (MUZ) SFX	07- 07	<b>LS</b>
	1000 (MUZ) SN	05- 05	<b>LS</b>
	1000 (MUZ) ST	07- 10	<b>LS</b>

## SBS 716 Recommended compound



<b>POLARIS</b>			
	250 2x4, 4x4	90- 93	<b>ATS</b>
	250 Big Boss 4x6, 6x6	89- 93	<b>ATS</b>
	250 Trail Blazer	90- 07	<b>ATS</b>
	250 Trail Boss	91- 99	<b>ATS</b>
	250 Trail Boss 2x4, 4x4	91- 92	<b>ATS</b>
	250 Xplorer 4x4	00- 02	<b>ATS</b>
	300 2x4, 4x4	94- 95	<b>ATS</b>
	300 Big Boss 6x6	94- 94	<b>ATS</b>
	300 Hawkeye 2x4, 4x4	07- 11	<b>ATS</b> <b>ATS</b>
	300 Xplorer 4x4	96- 99	<b>ATS</b>
	300 Xpress 2x4	98- 99	<b>ATS</b>
	300 Xpress L	96- 97	<b>ATS</b>
	325 Magnum 2x4, 4x4	00- 02	<b>ATS</b>
	325 Trail Boss	00- 02	<b>ATS</b>
	330 ATP	04- 05	<b>ATS</b> <b>ATS</b>
	330 ATP	06- 05	<b>ATS</b>
	330 Magnum 2x4, 4x4	03- 13	<b>ATS</b>
	330 Trail Boss	03- 14	<b>ATS</b>
	335 Sportsman 4x4	99- 02	<b>ATS</b>
	350 Big Boss	93- 93	<b>ATS</b>
	350 L 2x4, 4x4	90- 90	<b>ATS</b>
	350 L 4x4	93- 93	<b>ATS</b>
	350 Sportsman 4x4	93- 93	<b>ATS</b>
	350 Trail Boss 2x4, 4x4	88- 89	<b>ATS</b>
	350 Trail Boss L 2x4	91- 93	<b>ATS</b>
	350 Trail Boss L 4x4	91- 91	<b>ATS</b>
	400 Big Boss L 6x6	96- 96	<b>ATS</b>
	400 L 2x4	94- 95	<b>ATS</b>
	400 L 4x4	94- 94	<b>ATS</b>
	400 Scrambler 2x4, 4x4	00- 03	<b>ATS</b>
	400 Scrambler 4x4	98- 03	<b>ATS</b>



<b>POLARIS</b>			
	400 Scrambler L 4x4	95- 97	<b>ATS</b>
	400 Sport	99- 00	<b>ATS</b>
	400 Sport L	94- 98	<b>ATS</b>
	400 Sportsman	01- 13	<b>ATS</b>
	400 Sportsman L 4x4	94- 97	<b>ATS</b>
	400 Trail Blazer	03- 04	<b>ATS</b>
	400 Xplorer L 4x4	95- 02	<b>ATS</b>
	400 Xpress L	96- 97	<b>ATS</b>
	425 2x4, 4x4 Magnum	95- 98	<b>ATS</b>
	425 Magnum 6x6	96- 96	<b>ATS</b>
	425 Xpedition 4x4	00- 03	<b>ATS</b>
	450 Sportsman	06- 09	<b>ATS</b>
	455 Diesel EBS 4x4	99- 01	<b>ATS</b>
	500 ATP HO	04- 05	<b>ATS</b> <b>ATS</b>
	500 Big Boss 6x6	98- 99	<b>ATS</b>
	500 Magnum 2x4, 4x4	02- 07	<b>ATS</b>
	500 Magnum 4x4	00- 01	<b>ATS</b>
	500 Outlaw	06- 09	<b>ATS</b> <b>ATS</b>
	500 Predator	03- 13	<b>ATS</b> <b>ATS</b>
	500 Predator e	06- 13	<b>ATS</b>
	500 Ranger 6x6	00- 02	<b>ATS</b>
	500 Scrambler 2x4	01- 02	<b>ATS</b>
	500 Scrambler 4x4	97- 13	<b>ATS</b>
	500 Sportsman 4x4	96- 14	<b>ATS</b>
	500 Sportsman 6x6	00- 11	<b>ATS</b>
	500 Sportsman EBS 4x4	98- 02	<b>ATS</b>
	500 Xplorer 4x4	97- 97	<b>ATS</b>

Available compounds

**HF • LS • RQ • H.HF • H.CT • H.LS**

**SBS 715**

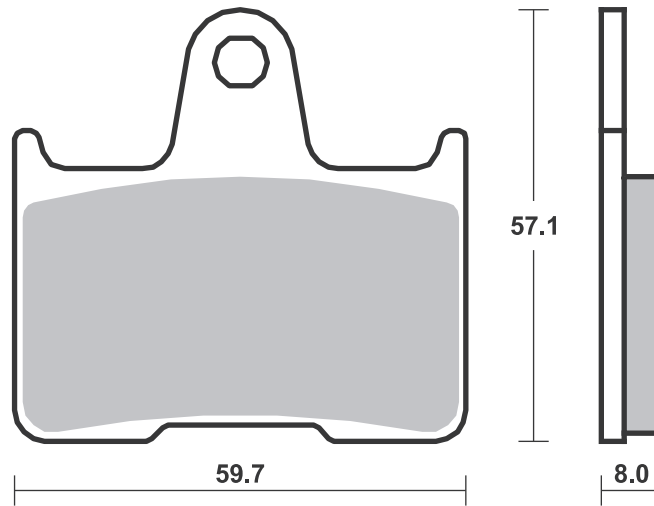

Available compounds

**HF • SI • RSI • ATS**

**SBS 716**

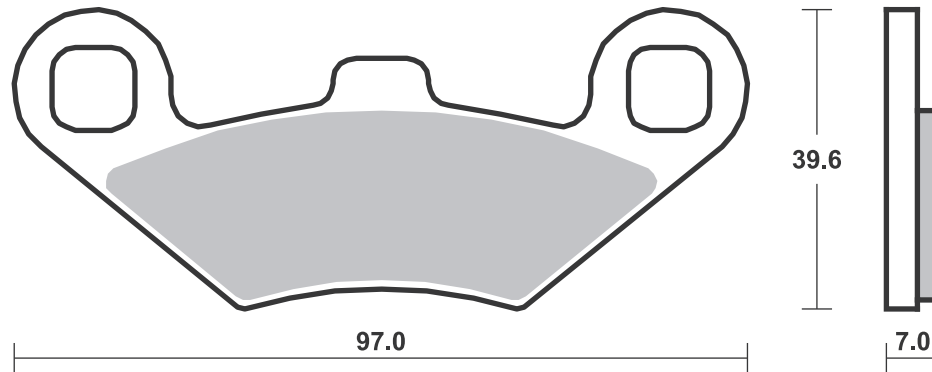





Available compounds

**HF • SI • RSI • ATS**

**SBS 717**

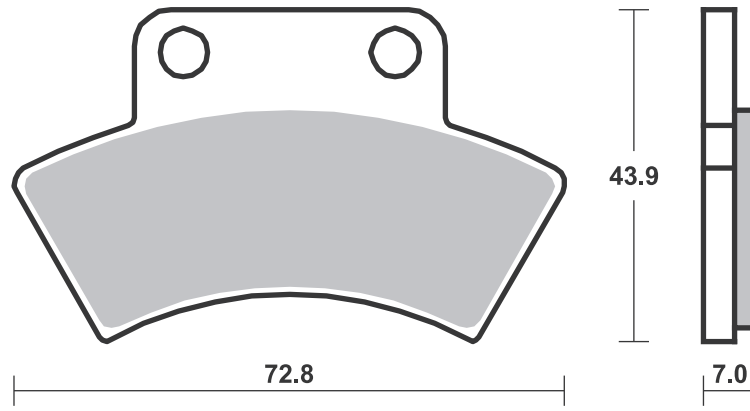

Available compounds

**HF • SI • RSI**

**SBS 718**

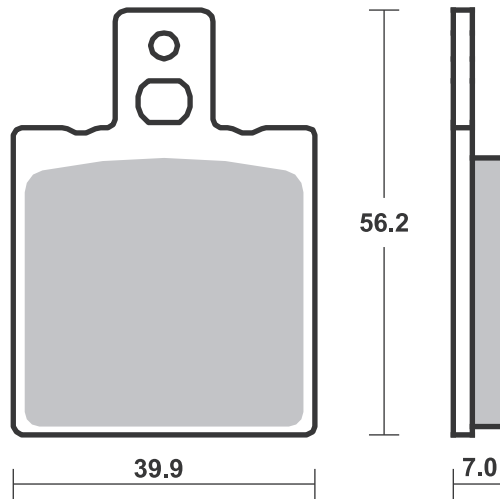



Available compounds

**RST • RQ**

**SBS 719**

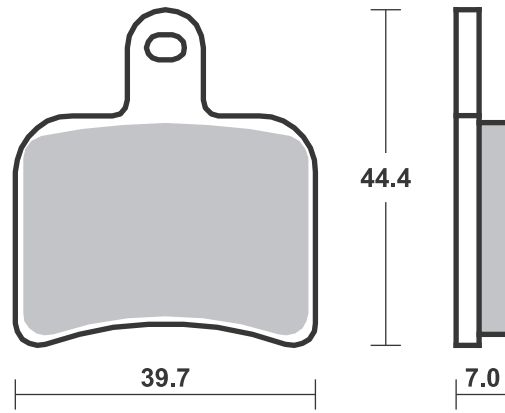

Available compounds

**RQ**

**SBS 720**

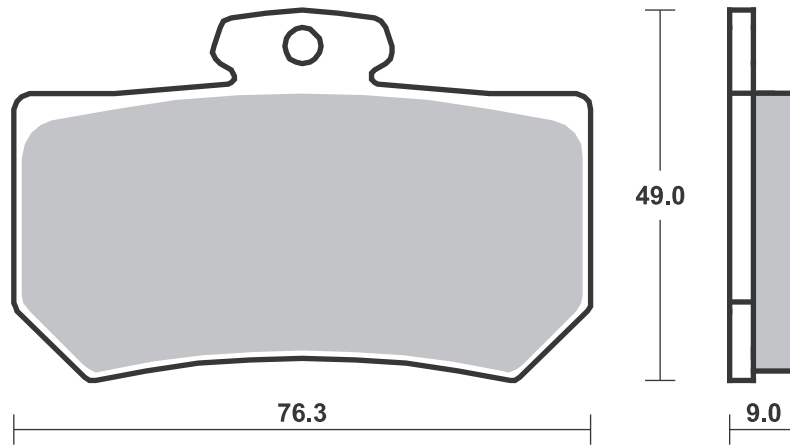



Available compounds

HF • HS

SBS 721

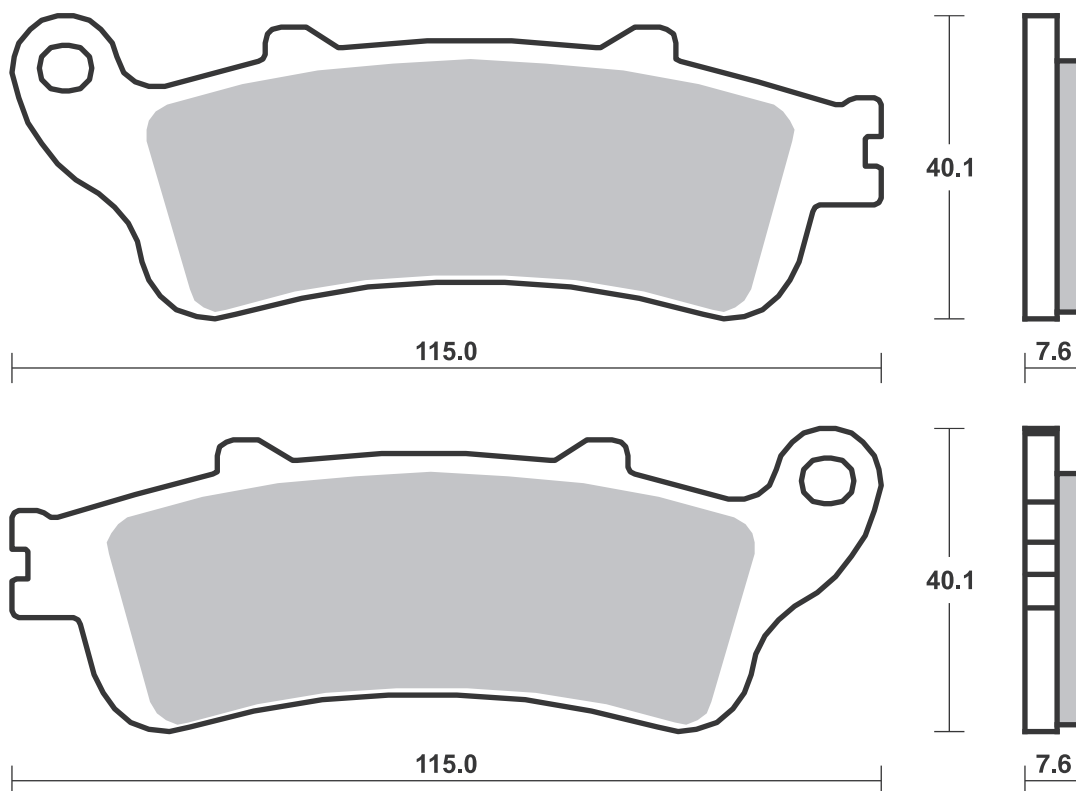

Available compounds

HF • LS

SBS 722

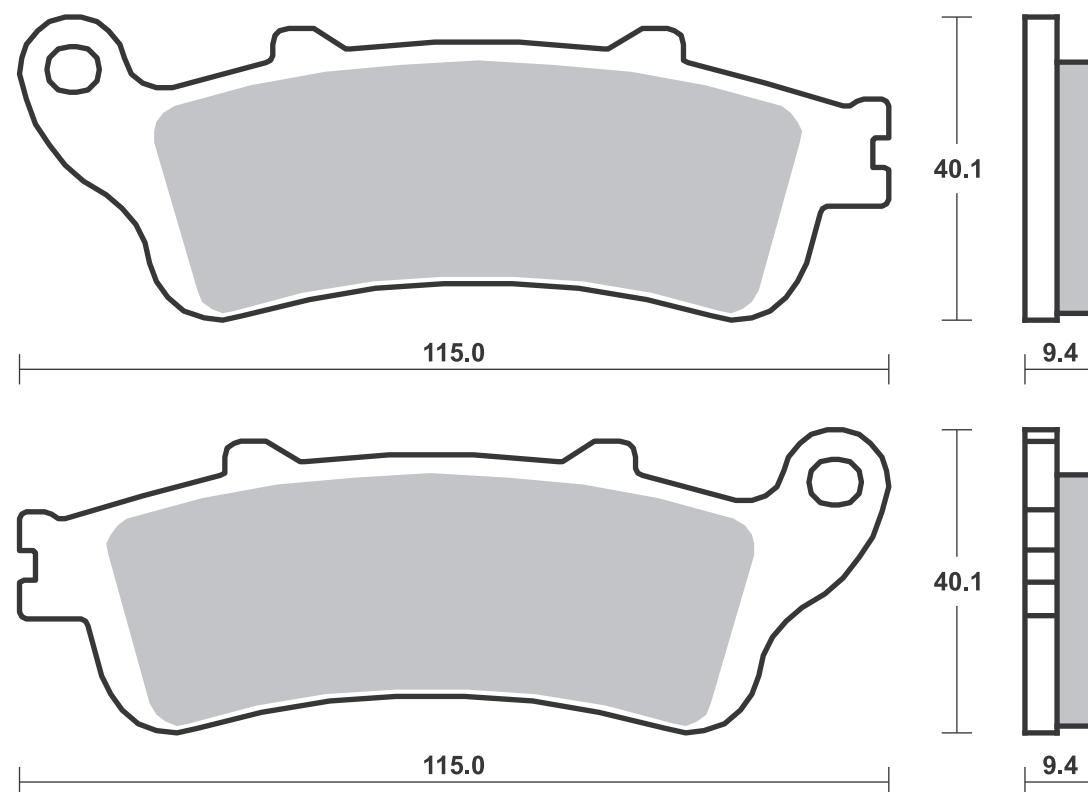

# Applications

## SBS 726 Recommended compound



### KAWASAKI

KX	80	97-00	RSI
KX	85	01-22	RSI
KX	85 II	01-22	RSI
KX	100	97-21	RSI
KX	112	22-22	RSI
KL	250 Super Sherpa	00-02	SI

### SUZUKI

RM	85	05-21	RSI
RM	100	03-03	RSI

## SBS 728 Recommended compound



### YAMAHA

TW	125	99-07	HF
DT	175	00-00	HF
TW	200	01-21	HF
XT	225	01-01	HF
XG	250 Tricker	05-11	HF
XT	250	08-08	HF
YZF	600 R6	99-02	LS
YZF	1000 R1	02-03	LS

## SBS 729 Recommended compound



### NISSIN

6 Piston Racing Caliper

### PERFORMANCE MACHINE

112 X 6B  
112 X 6QC

### YAMAHA

YZF	750 R7 OW02		
	Race kit	99-01	HS

Brake Pad 1:1 Drawings, Compounds, Fitments

Available compounds

CS • SI • RSI

SBS 726

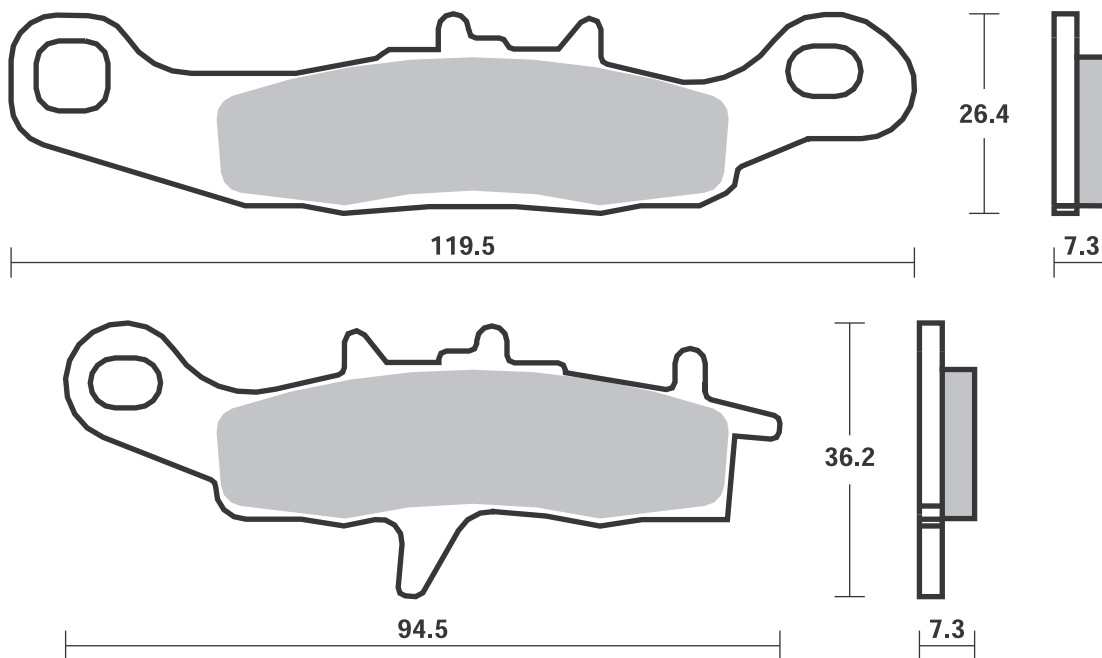

Available compounds

HF • LS • RQ

SBS 728

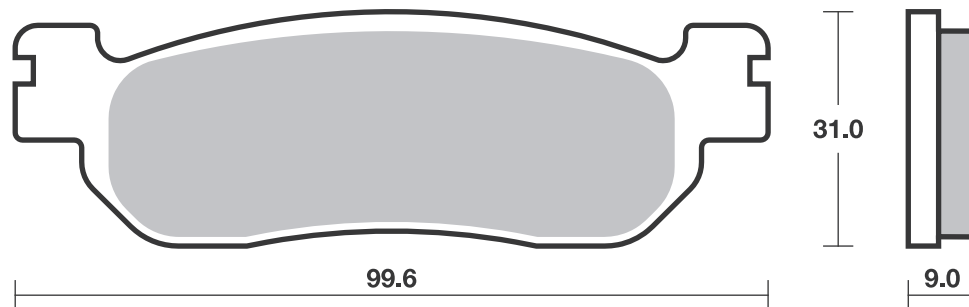

Available compounds

HF • HS • DC • H.HF • H.CT • H.HS

SBS 729

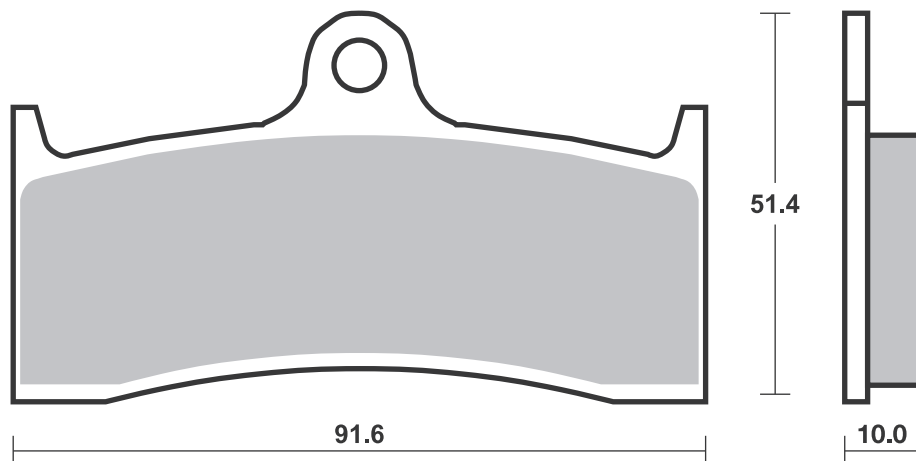



<b>APRILIA</b>			
660 Tuono			
Factory	22-22		<b>LS</b>
RS 660	20-22		<b>LS</b>
RS 660 Trofeo	22-22		<b>LS</b>
1000 Blue Marlin	02-02		<b>LS</b>
ETV 1000 Caponord	01-08		<b>LS</b>
ETV 1000 Caponord			
Rally Raid	04-08		<b>LS</b>
RSV 1000	97-03		<b>LS</b>
RSV 1000 Factory			
Pista	04-04		<b>LS</b>
RSV 1000 Falco SL, R	00-04		<b>LS</b>
RSV 1000 Nera	04-04		<b>LS</b>
RSV 1000 R	00-07		<b>LS</b>
RSV 1000 R Factory	04-08		<b>LS</b>
RSV 1000 SP	00-00		<b>LS</b>
RSV 1000 Tuono			
Fighter	03-05		<b>LS</b>
RSV 1000 Tuono R	03-03		<b>LS</b>
RSV 1000 Tuono R			
Factory,			
ABS	06-12		<b>LS</b>
RSV 1000 Tuono R,			
ABS	04-12		<b>LS</b>
RSV 1000 Tuono V4 R	11-14		<b>LS</b>
RSV4 1000 , ABS	09-13		<b>LS</b>
RSV4-R 1000 , ABS APRC	10-10		<b>LS</b>
RSV4-RF 1000	15-20		<b>LS</b>
RSV4-RR 1000	15-20		<b>LS</b>
RSV 1100 Tuono V4	15-15		<b>LS</b>
RSV 1100 Tuono V4			
Factory	15-18		<b>LS</b>
RSV 1100 Tuono V4			
RR	15-19		<b>LS</b>
RSV4 1100 Factory	19-20		<b>LS</b>
<b>BENELLI</b>			
500 C	19-19		<b>LS</b>
500 Leoncino	16-17		<b>LS</b>
TRK 502	16-17		<b>LS</b>
BN 600	12-17		<b>LS</b>
BN 600 GT	14-15		<b>LS</b>
T 600 Tornado			
Naked	20-20		<b>LS</b>
752 S	20-20		<b>LS</b>
756 Cue	07-12		<b>LS</b>
800 Leoncino	20-20		<b>LS</b>
899 Trek	07-12		<b>LS</b>
TnT 899	07-15		<b>LS</b>
TnT 899 Century			
Racer	11-11		<b>LS</b>
900 Tornado			
TRE	03-06		<b>LS</b>
900 Tornado			
TRE RS	04-06		<b>LS</b>
TnT 1130	05-14		<b>LS</b>
TnT 1130 Cafe Racer	05-13		<b>LS</b>
TnT 1130 Century			
Racer	11-12		<b>LS</b>
TnT 1130 Officine	07-07		<b>LS</b>
TnT 1130 R	17-17		<b>LS</b>
TnT 1130 Sport	05-08		<b>LS</b>
TnT 1130 Titanium	05-08		<b>LS</b>
TnT 1130 Trek	06-12		<b>LS</b>
TnT 1130 Trek			
Amazonas	07-15		<b>LS</b>



<b>BIMOTA</b>			
3D 800 Tesi	16-16		<b>LS</b>
BB3 1000	14-18		<b>LS</b>
DB5 1000	05-11		<b>LS</b>
DB5 1000 S	07-11		<b>LS</b>
DB6 1000 Delirio	07-09		<b>LS</b>
DB10 1078 Bimotard	12-12		<b>LS</b>
DB5 1078 RE	12-12		<b>LS</b>
DB7 1098	08-08		<b>LS</b>
3D 1100 Tesi	07-11		<b>LS</b>
DB6R 1100 Delirio	08-09		<b>LS</b>
DB8 1198	10-14		<b>LS</b>
1200 Impeto	16-17		<b>LS</b>
DB11 1200 VLX	13-13		<b>LS</b>
DB12 1200	12-12		<b>LS</b>
DB9 1200 Brivido	12-18		<b>LS</b>
<b>BOMBARDIER</b>			
500 Traxter 4x4	99-00	<b>HF</b>	<b>HF</b>
<b>BRAMMO</b>			
Empulse	14-16		<b>LS</b>
<b>BREMO RACING CALIPERS</b>			
Goldline 20.6951.50, road			
Supersport 120A44110, P2 34			
<b>CAGIVA</b>			
650 Raptor	01-08		<b>LS</b>
650 V-Raptor	01-08		<b>LS</b>
1000 Raptor	00-08		<b>LS</b>
1000 V-Raptor	00-08		<b>LS</b>
1000 X3 Raptor	04-04		<b>LS</b>
1000 X-Raptor	03-04		<b>LS</b>
1000 Xtra Raptor	02-06		<b>LS</b>
<b>CF MOTO</b>			
700 CL-X Sport	22-22		<b>LS</b>
<b>DERBI</b>			
GP1 50	05-05	<b>HF</b>	
GPR 50 Nude	04-10	<b>HF</b>	
GPR 50 Racing	04-13	<b>HF</b>	
GP1 125	05-06	<b>HF</b>	
GP1 250	05-09	<b>HF</b>	
659 Mulhacen	05-07		<b>LS</b>
659 Mulhacen Cafe	08-08		<b>LS</b>
<b>DUCATI</b>			
620 Multistrada	05-06		<b>LS</b>
620 Multistrada			
Dark	05-06		<b>LS</b>
620 Sport	03-06		<b>LS</b>
696 Monster	08-12		<b>LS</b>
749 , S	03-07		<b>LS</b>
749 R	04-07		<b>LS</b>
750 Sport	00-02		<b>LS</b>
750 Super Sport	00-02		<b>LS</b>
795 Monster	12-12		<b>LS</b>
796 Hypermotard	10-12		<b>LS</b>
796 Monster	11-14		<b>LS</b>
796 Monster ABS	11-14		<b>LS</b>
800 Sport	03-06		<b>LS</b>
800 Supersport	03-06		<b>LS</b>
821 Hypermotard	13-16		<b>LS</b>
821 Hypermotard			
ABS	13-16		<b>LS</b>
821 Hypermotard SP	13-16		<b>LS</b>



<b>DUCATI</b>			
821 Hypermotard			
SP ABS	13-16		<b>LS</b>
821 Hyperstrada	13-16		<b>LS</b>
821 Hyperstrada			
ABS	13-16		<b>LS</b>
821 Monster	14-21		<b>LS</b>
821 Monster Dark	15-16		<b>LS</b>
821 Monster Stealth	19-21		<b>LS</b>
848	08-10		<b>LS</b>
848 EVO	11-12		<b>LS</b>
848 Streetfighter	12-15		<b>LS</b>
848 Streetfighter S	12-15		<b>LS</b>
899 Panigale	14-15		<b>LS</b>
900 Super Sport	98-02		<b>LS</b>
916 Sport Touring 4	99-01		<b>LS</b>
937 Monster	20-22		<b>LS</b>
937 Monster +	20-22		<b>LS</b>
939 Hypermotard	16-18		<b>LS</b>
939 Hypermotard SP	16-18		<b>LS</b>
939 Hyperstrada	16-16		<b>LS</b>
939 SuperSport	17-20		<b>LS</b>
939 SuperSport S	17-20		<b>LS</b>
944 Sport Touring	98-03		<b>LS</b>
944 ST2	97-03		<b>LS</b>
950 Hypermotard	19-22		<b>LS</b>
950 Hypermotard SP	19-22		<b>LS</b>
950 Supersport	20-22		<b>LS</b>
950 Supersport S	20-22		<b>LS</b>
955 Panigale V2	20-22		<b>LS</b>
955 Panigale V2			
Bayliss	22-22		<b>LS</b>
955 Streetfighter V2	22-22		<b>LS</b>
959 Panigale	16-20		<b>LS</b>
959 Panigale Corse	18-20		<b>LS</b>
D16RR 990 Desmosedici			
RR	07-08		<b>LS</b>
992 ST3	04-07		<b>LS</b>
992 ST3s ABS	06-07		<b>LS</b>
996 ST4s	02-06		<b>LS</b>
996 ST4s ABS	03-06		<b>LS</b>
998 Monster S4Rs	06-06		<b>LS</b>
998 Panigale V4 R	19-21		<b>LS</b>
998 Superleggera V4	20-21		<b>LS</b>
999	03-07		<b>LS</b>
999 Monster S4R	07-08		<b>LS</b>
999 Monster S4RS	07-08		<b>LS</b>
999 R	03-07		<b>LS</b>
999 RS			
(slipper clutch)	04-05		<b>LS</b>
999 S	03-07		<b>LS</b>
1000 Hypermotard	06-06		<b>LS</b>
1000 Monster S2R	06-07		<b>LS</b>
1000 Multistrada	07-07		<b>LS</b>
1000 Multistrada DS	03-06		<b>LS</b>
1000 Multistrada S DS	05-06		<b>LS</b>
1000 Supersport DS	03-06		<b>LS</b>
1098	07-08		<b>LS</b>
1098 R	08-10		<b>LS</b>
1098 R Bayliss LE	09-10		<b>LS</b>
1098 S	07-08		<b>LS</b>
1098 Streetfighter	09-14		<b>LS</b>
1098 Streetfighter S	09-13		<b>LS</b>
1100 Hypermotard	07-09		<b>LS</b>
1100 Hypermotard			
EVO	10-12		<b>LS</b>
1100 Hypermotard			
EVO SP	10-12		<b>LS</b>



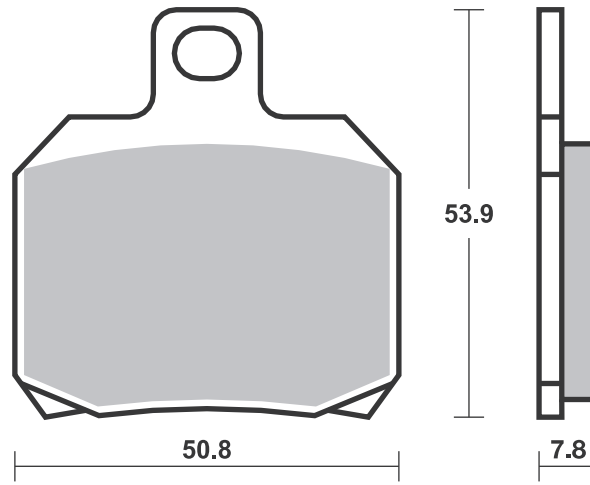



<b>DUCATI</b>		
1100 Hypermotard S	07-09	LS
1100 Monster	09-13	LS
1100 Monster ABS	09-10	LS
1100 Monster EVO	11-13	LS
1100 Monster EVO		
ABS	11-13	LS
1100 Monster S	09-13	LS
1100 Monster S		
ABS	09-10	LS
1100 Multistrada	07-09	LS
1100 Multistrada S	07-09	LS
1100 Panigale V4	18-21	LS
1100 Panigale V4 S	18-21	LS
1100 Panigale V4 S		
Corse	19-19	LS
1100 Panigale V4 SP	21-21	LS
1100 Panigale V4		
Speciale	18-19	LS
1103 Streetfighter V4	20-22	LS
1103 Streetfighter V4		
S	20-22	LS
1103 Streetfighter V4		
SP	22-22	LS
1198	09-13	LS
1198 S	09-12	LS
1198 SP	11-12	LS
1199 Panigale	12-14	LS
1199 Panigale R	13-15	LS
1199 Panigale S	12-14	LS
1199 Superleggera	14-14	LS
1200 Monster	14-21	LS
1200 Monster 25		
Anniversario	19-19	LS
1200 Monster R	16-19	LS
1200 Monster S	14-21	LS
1200 Multistrada	10-14	LS
1200 Multistrada S		
GT	12-14	LS
1200 Multistrada S		
Pikes Peak	11-14	LS
1200 Multistrada S		
Sport	10-14	LS
1200 Multistrada S		
Touring	10-14	LS
1299 Panigale	15-17	LS
1299 Panigale R	15-17	LS
1299 Panigale R		
Final Edition	17-20	LS
1299 Panigale S	15-17	LS
1299 Panigale S		
Anniversario	17-17	LS
1299 Superleggera	17-17	LS

<b>ENERGICA</b>		
Ego	15-21	LS
Eva EsseEsse9	18-21	LS
Eva Ribelle	15-21	LS

<b>GALESPEED</b>		
2 Piston Axial Rear Caliper, GSRCA34AF		
2 Piston Axial Rear Caliper, GSRCA34AT		
2 Piston Radial Rear Caliper, GSRCA30F (30mm Piston)		
2 Piston Radial Rear Caliper, GSRCA30T (30mm Piston)		



<b>GALESPEED</b>		
2 Piston Radial Rear Caliper, GSRCA34F (34mm Piston)		
2 Piston Radial Rear Caliper, GSRCA34T (34mm Piston)		

<b>GILERA</b>		
600 Supersport	02-02	LS

<b>HARLEY DAVIDSON</b>		
Livewire	19-21	LS

<b>HONDA</b>		
CBR 1000 RR-R		
Fireblade	20-22	LS
CBR 1000 RR-R SP		
Fireblade	20-22	LS
RC213V-S 1000	16-18	LS

<b>INDIAN</b>		
FTR 1200	19-20	LS
FTR 1200 S	19-20	LS

<b>KAWASAKI</b>		
ZX 1000 H2 Carbon		
Ninja	17-20	LS
ZX 1000 H2 Ninja	15-21	LS
ZX 1000 H2R Ninja	15-20	LS

<b>KTM</b>		
RC8 890 C	22-22	LS
RC8 1190	08-11	LS
RC8 1190 R	09-15	LS
RC8 1190 R Track	11-15	LS
1290 Super Duke		
GT	16-20	LS
1290 Super Duke		
R	14-22	LS
1290 Super Duke		
R EVO	22-22	LS
1290 Superduke		
R Black	20-20	LS

<b>LAVERDA</b>		
TTS 800	99-99	HF
SFC 1000	04-04	LS

<b>MONDIAL</b>		
1000 EVO	04-04	LS
1000 Piegia	03-04	LS
1000 RZ Nuda	04-04	LS
1000 Starfighter	04-04	LS

<b>MOTO-GUZZI</b>		
750 Brevia	03-09	LS
750 Nevada		
Classic ie	06-11	HF
750 Nevada, Nevada		
Club	03-16	HF
V7 750 Cafe		
Classic	10-13	LS
V7 750 Classic	09-12	LS
V7 750 Clubman		
Racer	10-10	LS
V7 750 Racer	11-11	LS
850 Brevia	06-09	LS
V 1100 Brevia	04-04	LS



<b>MOTO-GUZZI</b>		
1200 MGS-01		
Corsa	05-13	LS
1200 Sport 4V	09-11	LS

<b>MOTO-MORINI</b>		
649 X-Cape	22-22	LS
1200 11 1/2	18-18	LS
1200 9 1/2	06-09	LS
1200 Corsaro	06-13	LS
1200 Corsaro ZT	20-20	LS
1200 Corsaro ZZ	18-20	LS
1200 Milano	18-19	LS
1200 Scrambler	18-18	LS
1200 Sport	08-13	LS
1200 Super		
Scrambler	20-20	LS

<b>MOTUS</b>		
MST 1650	14-17	LS
MST-R 1650	14-17	LS

<b>MV AGUSTA</b>		
675 Brutale	12-15	LS
F3 675	13-20	LS
F3 675 RC	16-20	LS
800 Brutale	13-20	LS
800 Brutale		
Dragster	15-19	LS
800 Brutale		
Dragster RC	17-20	LS
800 Brutale		
Dragster RR	15-19	LS
800 Brutale		
Dragster		
RR LH44	18-20	LS
800 Brutale		
Dragster		
RR Pirelli	18-20	LS
800 Brutale RC	18-20	LS
800 Brutale RR	16-20	LS
800 Rivale	13-17	LS
800 RVS#1	18-20	LS
800 Stradale	15-16	LS
800 Superverloce	19-20	LS
800 Turismo Veloce	14-19	LS
800 Turismo Veloce		
Lusso	14-20	LS
800 Turismo Veloce		
RC	17-20	LS
F3 800 RC	16-20	LS
F3 800 RR	21-22	LS
1000 Brutale RR	20-20	LS

<b>NORTON</b>		
961 Commando		
Cafe Racer	11-14	LS
961 Commando		
Cafe Racer		
MKII	18-19	LS
961 Commando SE	10-14	LS
961 Commando SF	13-15	LS
961 Commando SF		
Sport	11-15	LS
961 Commando		
Sport	18-19	LS
961 Dominator		
Naked	17-19	LS

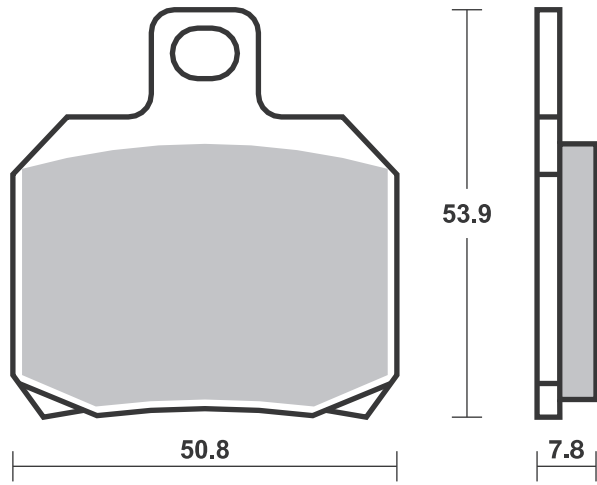

# Applications

## SBS 730 Recommended compound



### NORTON

1200 V4 RR	18- 19	LS
------------	--------	----

### TRIUMPH

1200 Speed Triple RR	22- 22	LS
-------------------------	--------	----

1200 Speed Triple RS	21- 22	LS
-------------------------	--------	----

### VICTORY

Empulse TT	16- 17	LS
------------	--------	----

## SBS 732 Recommended compound



### BREMBO RACING CALIPERS

Billet P2.24 X20.60.01, racing		
--------------------------------	--	--

Brake Pad 1:1 Drawings,  
Compounds, Fitments

Available compounds

**HF • LS • RQ**

**SBS 730**

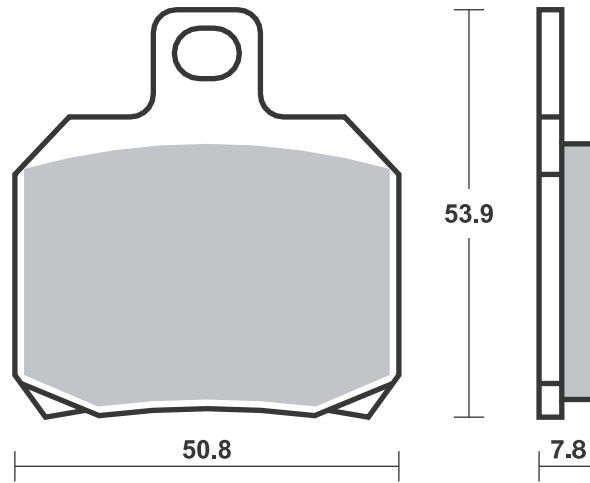

Available compounds

**RQ**

**SBS 732**

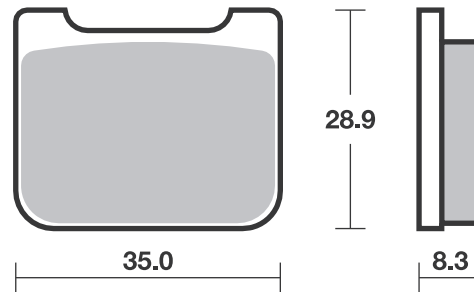



Available compounds

HF • LS • RQ

SBS 733

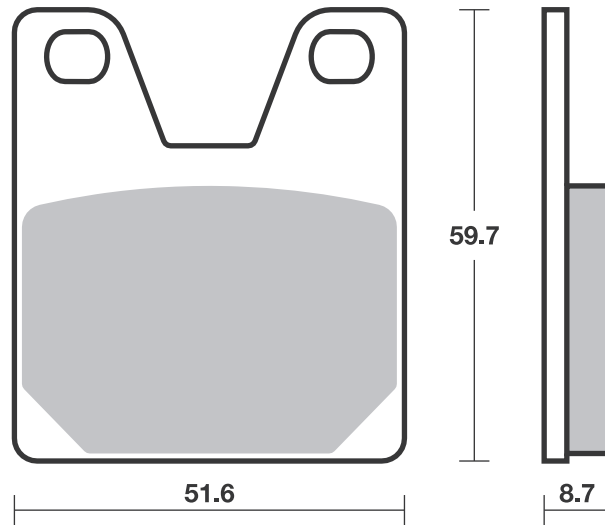

Available compounds

HF • HS • SP • DC • RST

SBS 734

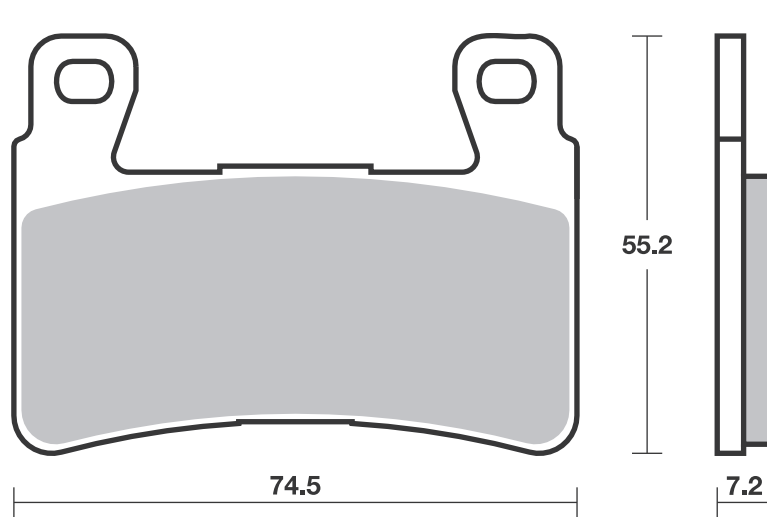

HF / HS / SP - Th. 7.2  
RST / DC - Th. 8.0

# Applications

## SBS 735 Recommended compound



<b>HONDA</b>			
NT	650 V Deauville	02-05	<b>HS</b>
VFR	800 FI Interceptor,		
	ABS	02-05	<b>HS</b>
VFR	800 Interceptor	98-01	<b>HS</b>
CB	1100 X-11	00-03	<b>HS</b>
CBR	1100 XX Super		
	Blackbird	96-07	<b>HS</b>
ST	1300 , ABS	02-07	<b>HS</b>
GL	1800 Gold Wing	01-17	<b>HS</b>
GL	1800 Gold Wing		
	F6B	13-16	<b>HS</b>
NRX	1800 Valkyrie Rune	04-05	<b>HS</b>
VTX	1800	01-12	<b>HS</b>
<b>KAWASAKI</b>			
EN	650 Vulcan S	15-19	<b>HS</b>
EN	650 Vulcan S Cafe	17-19	<b>HS</b>
EN	650 Vulcan S SE	17-18	<b>HS</b>
<b>VICTORY</b>			
	1731 Vision		
	all models	08-17	<b>H.HS</b>

## SBS 736 Recommended compound



<b>HONDA</b>			
NT	650 V Deauville	02-05	<b>LS</b>
NT	700 Deauville ABS	06-12	<b>LS</b>
NT	700 V Varadero,		
	ABS	10-13	<b>LS</b>
VFR	800 FI Interceptor,		
	ABS	02-05	<b>LS</b>
VFR	800 Interceptor	98-01	<b>LS</b>
VFR	800 Interceptor	06-18	<b>LS</b>
VFR	800 Interceptor		
	ABS	06-18	<b>LS</b>
CB	1100 X-11	00-03	<b>LS</b>
CBR	1100 XX Super		
	Blackbird	96-07	<b>LS</b>
VT	1300 CXA A Fury		
	ABS	10-18	<b>LS</b>
NRX	1800 Valkyrie Rune	04-05	<b>LS</b>
VTX	1800	01-12	<b>LS</b>

Brake Pad 1:1 Drawings, Compounds, Fitments



Available compounds

**HF • HS • SP • H.HF • H.CT • H.HS**

**SBS 735**

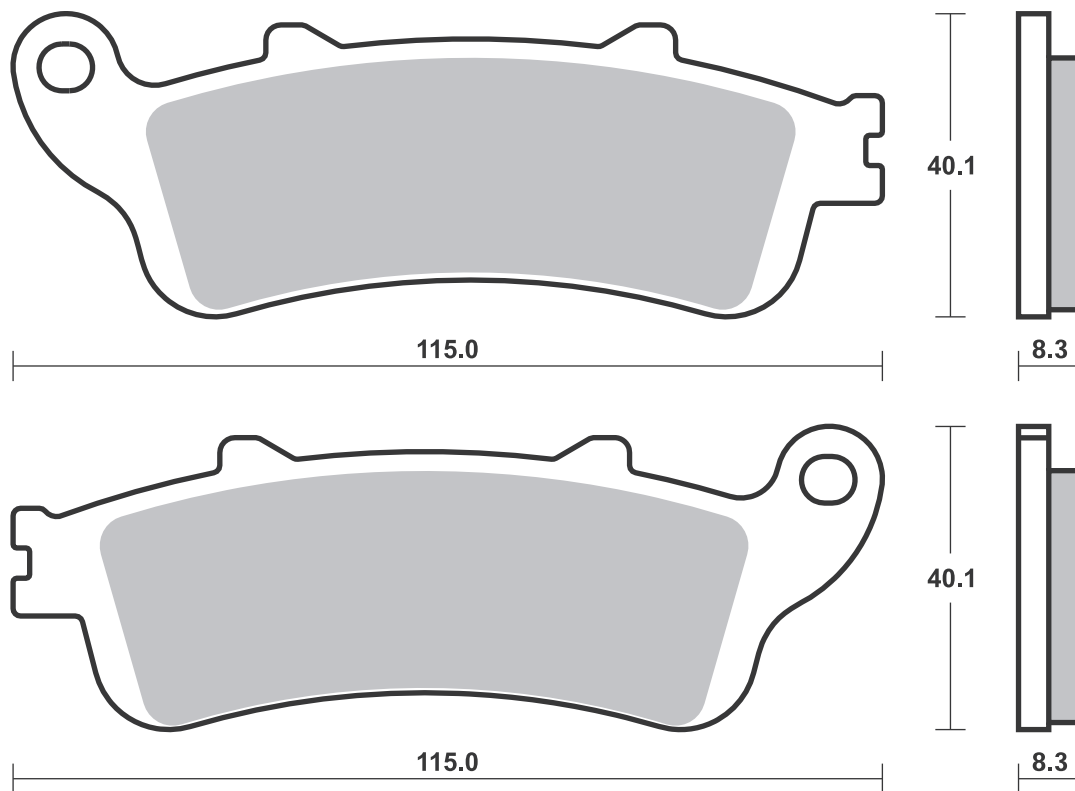

Available compounds

**HF • LS**

**SBS 736**

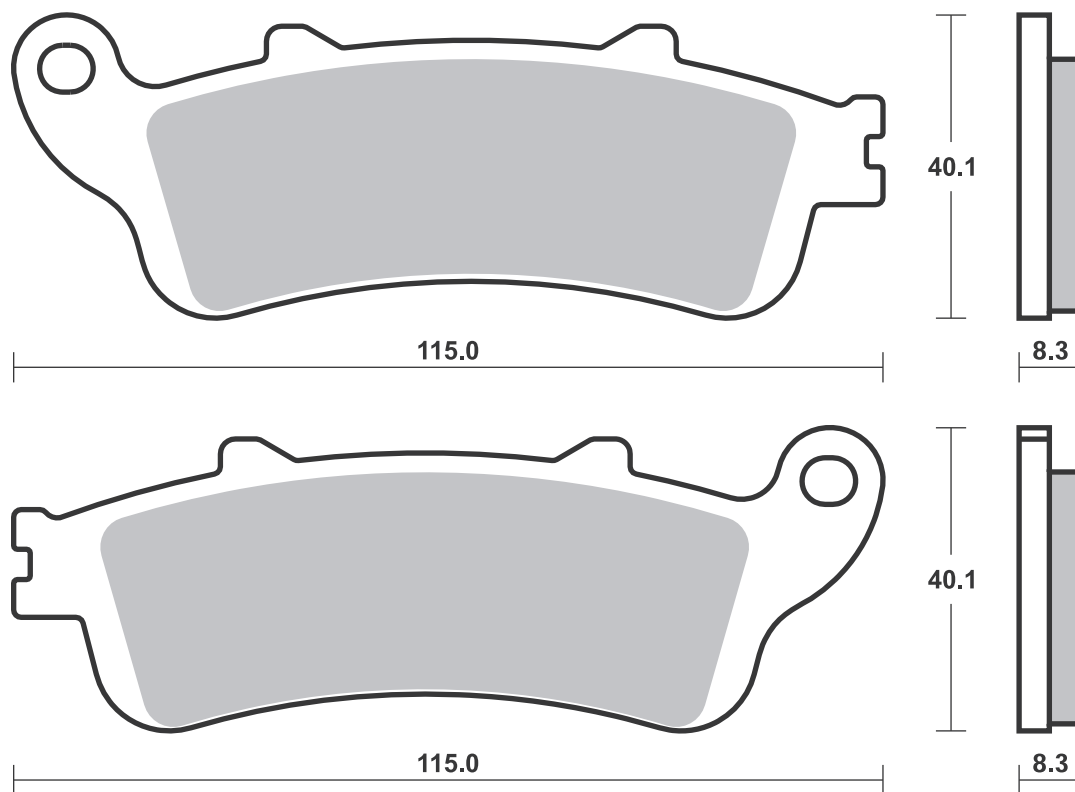



Available compounds

HF • H.HF • H.CT

SBS 737

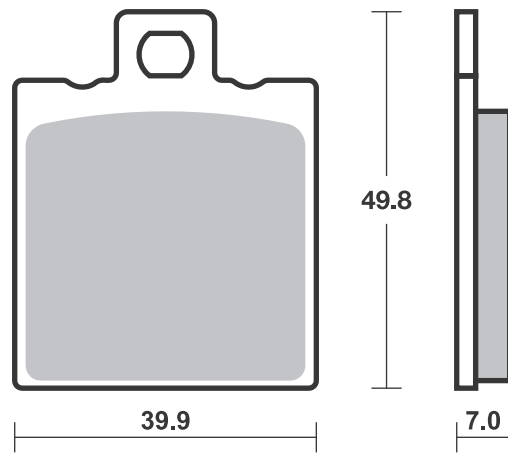

Available compounds

H.HS • H.LS

SBS 739

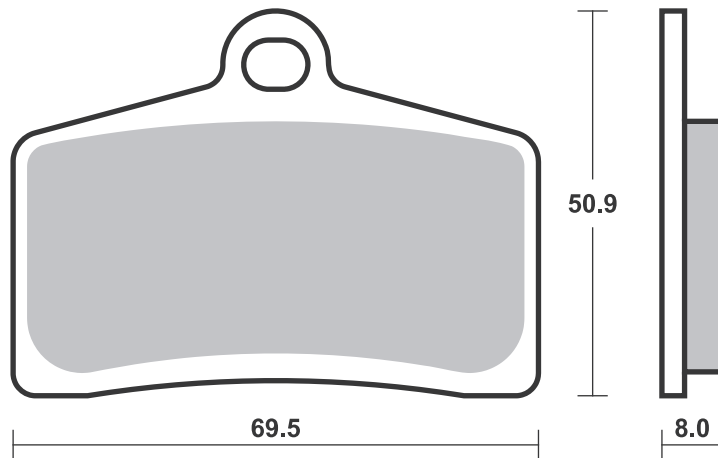

Available compounds

HF • HS • SP

SBS 740

1 set = 4 pcs.

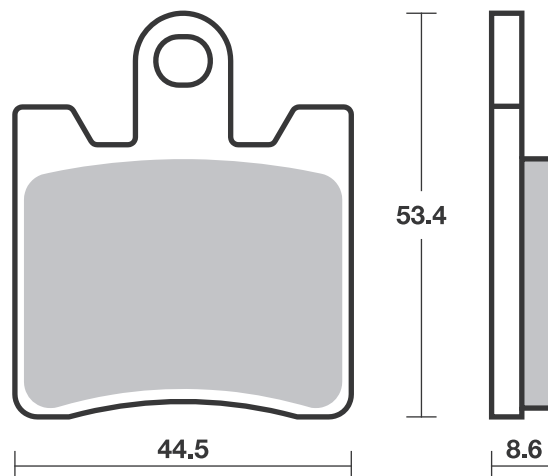



Available compounds

HF • LS • RQ

SBS 742

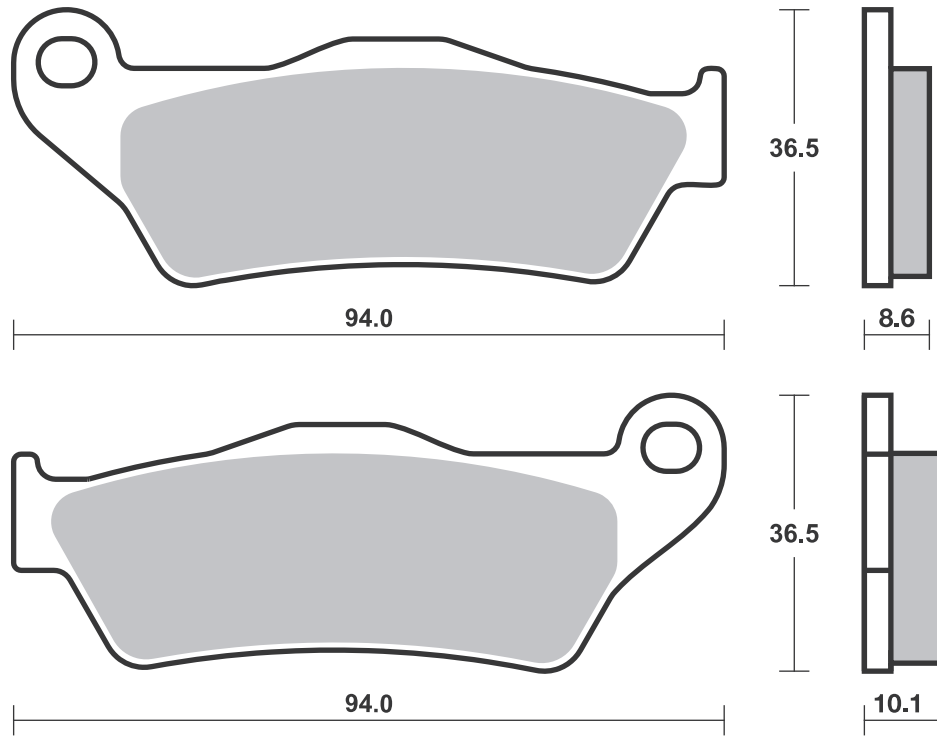

Available compounds

HF

SBS 746

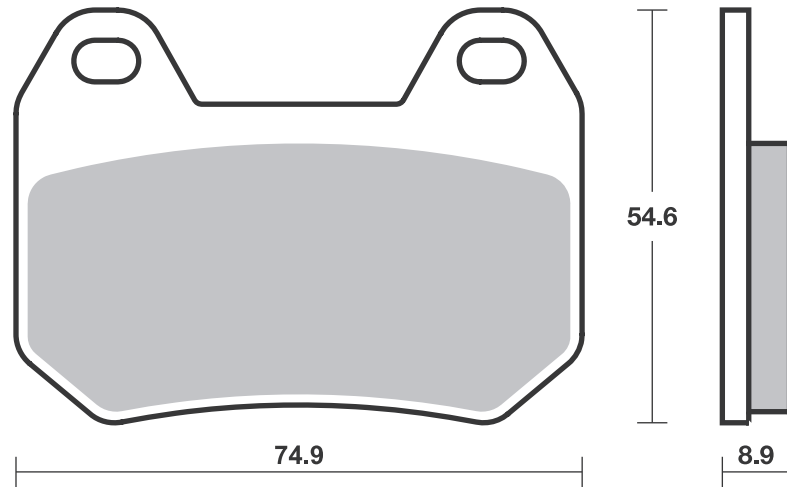

**SBS 747** Recommended compound



**HYOSUNG**

GD	250 EXIV-R	15- 17	HF
GT	250 iR	15- 15	HF
GT	300 R	16- 17	HF
GT	650 iR	15- 15	HF

**SBS 749** Recommended compound



**KYMCO**

	50 MXU	05- 10	HF
	150 MXU	05- 17	HF

Available compounds

HF • RQ

SBS 747

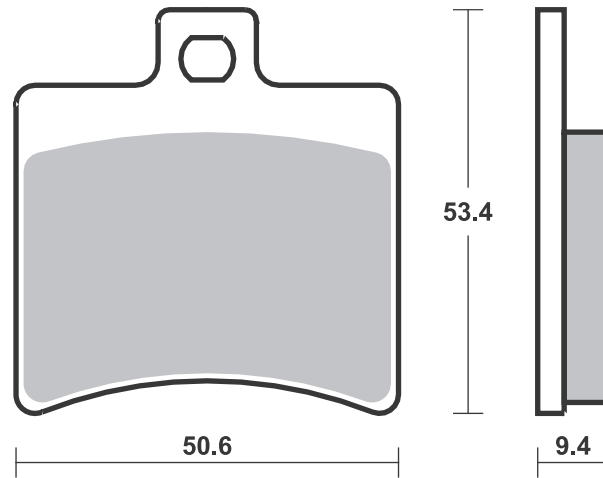

Available compounds

HF • SI

SBS 749

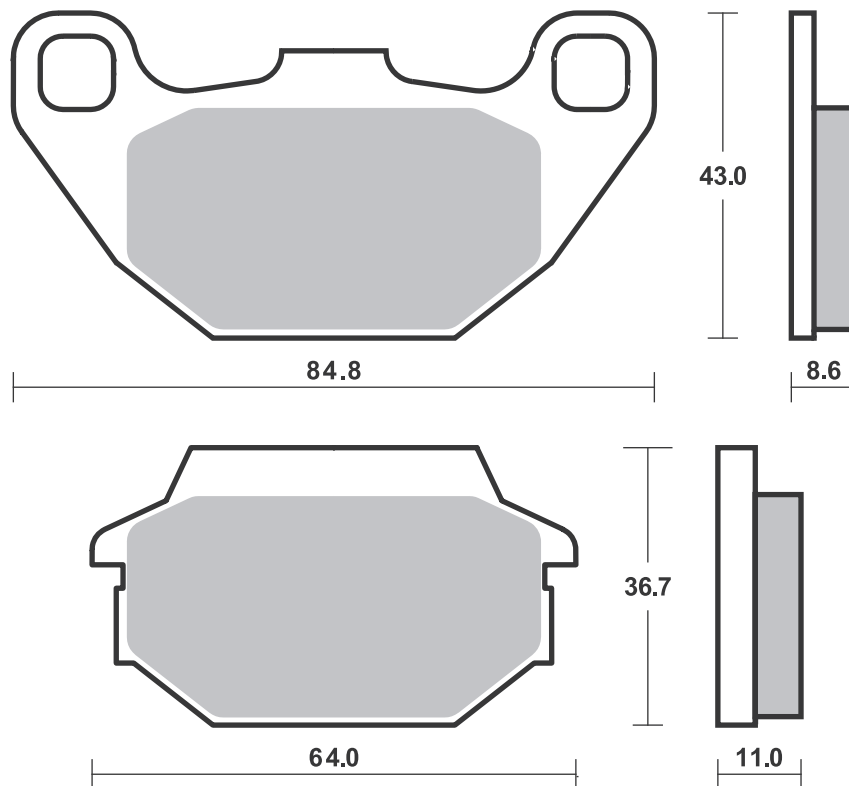





Available compounds

CS • SI • RSI

SBS 752

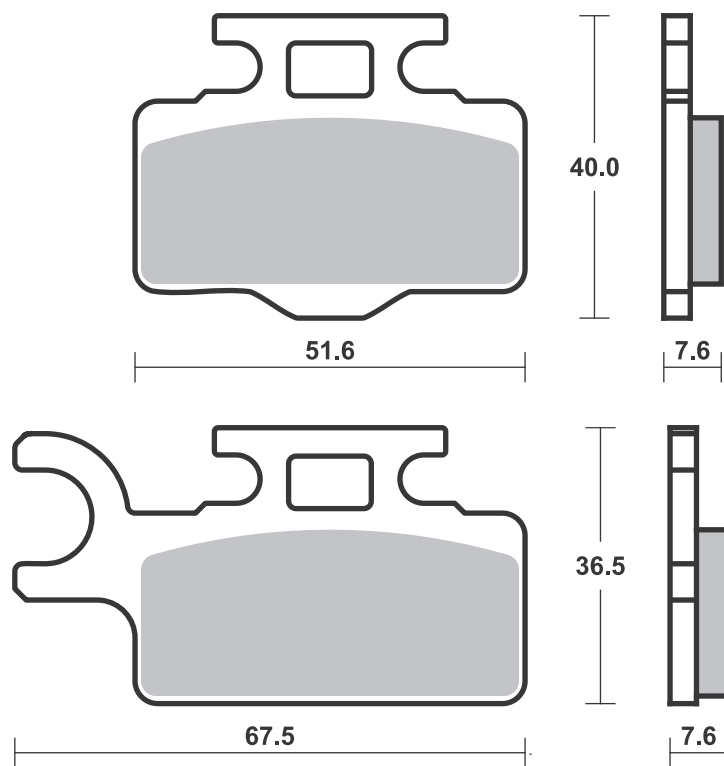

Available compounds

HF • SI • RSI • PSI

SBS 754

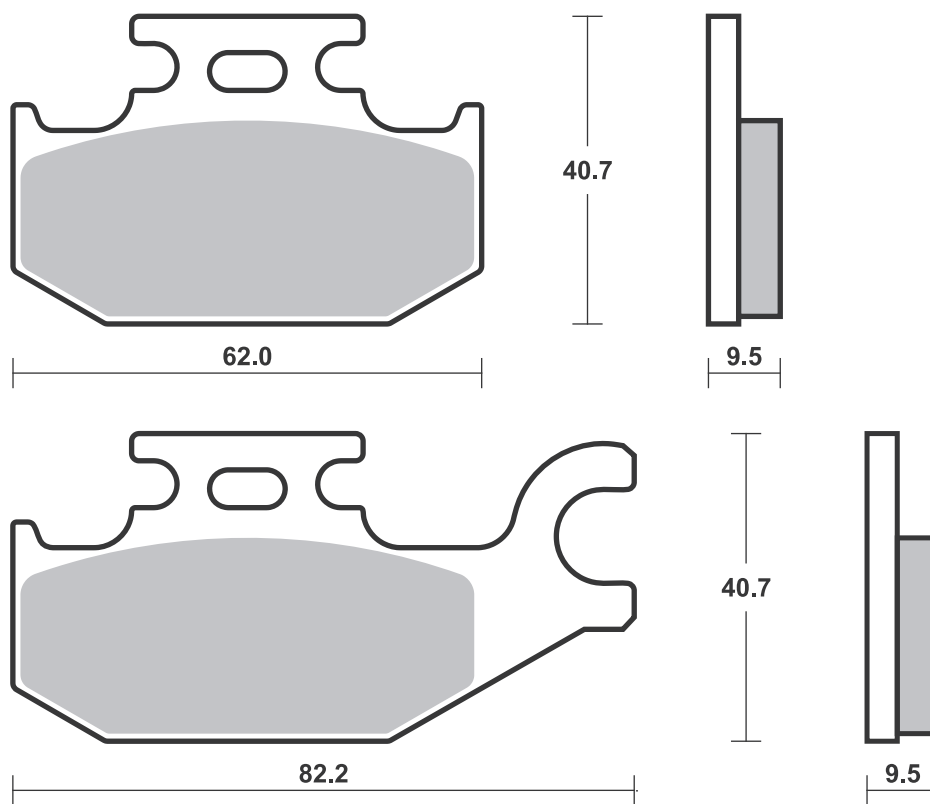



Available compounds

SI • RSI • ATS

SBS 755

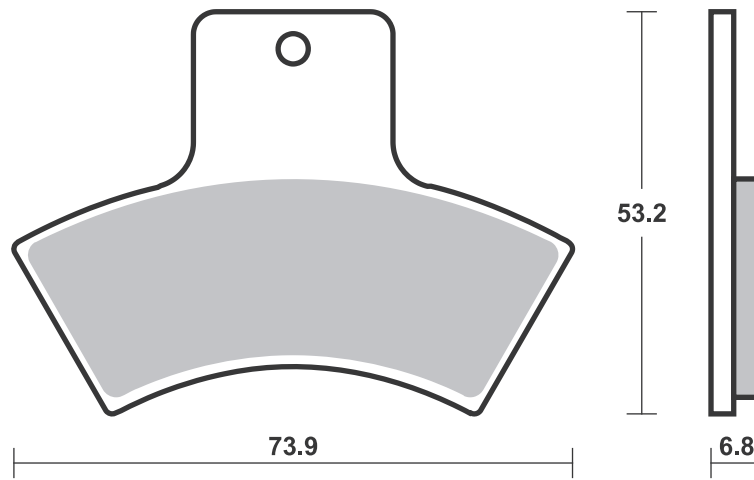

Available compounds

SI • RSI • ATS

SBS 756

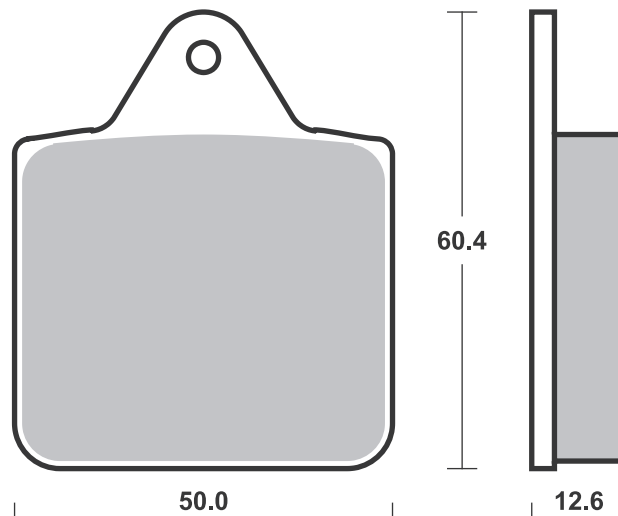



Available compounds

SI • RSI • ATS

SBS 757

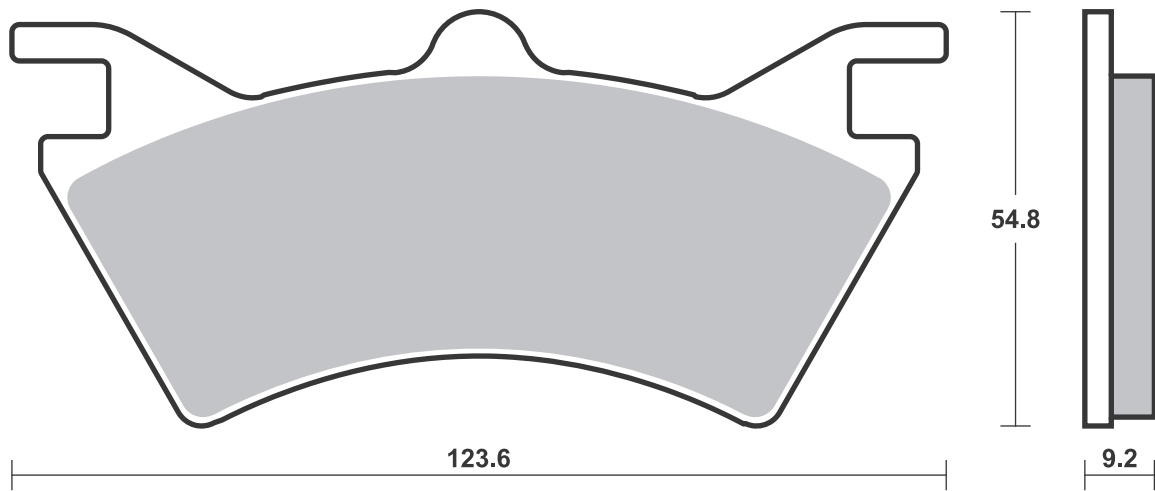

Available compounds

SI • RSI • ATS

SBS 758

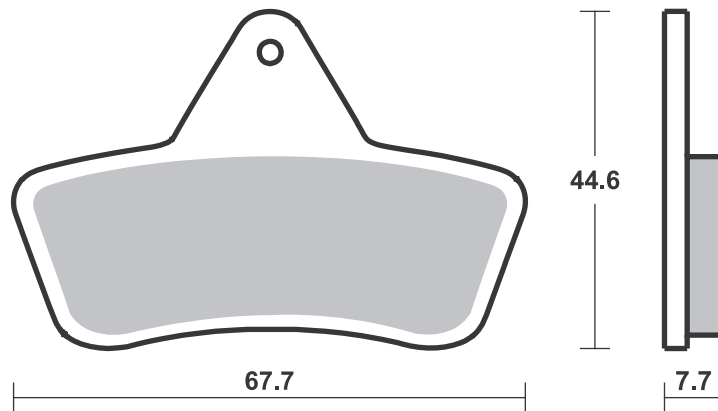



Available compounds

**RQ**

**SBS 759**

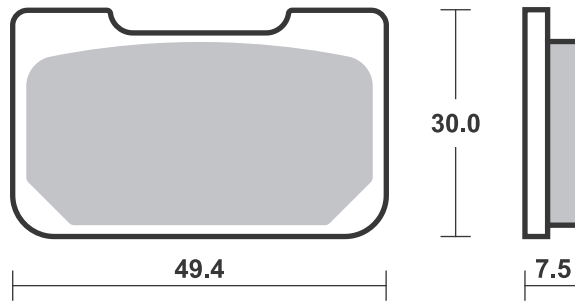

Available compounds

**HF • HS • SP • DC • RST • DS-1**

**SBS 762**

1 set = 4 pcs.

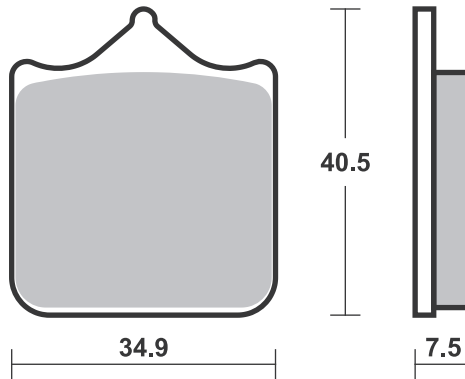





Available compounds

HF • HS • SP • DC • RST • DS-1

SBS 762

1 set = 4 pcs.

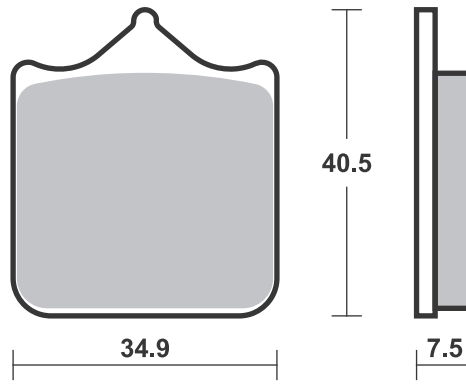

Available compounds

HF • LS • RQ

SBS 763

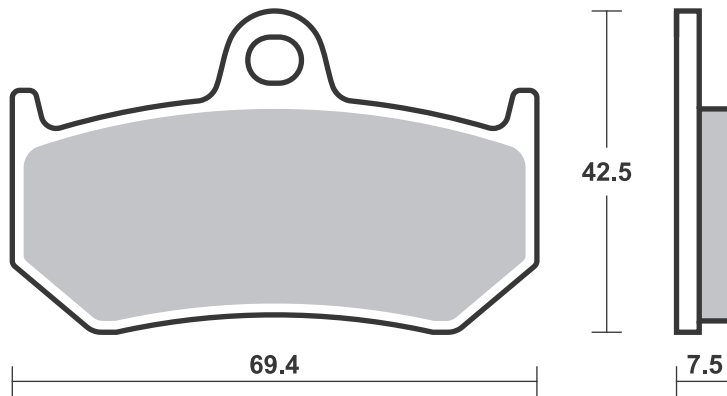

Available compounds

HF • LS • RQ

SBS 765

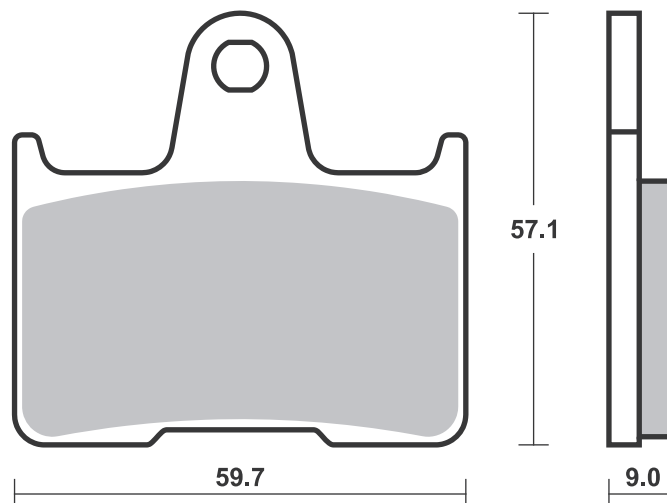



Available compounds

LS

SBS 766

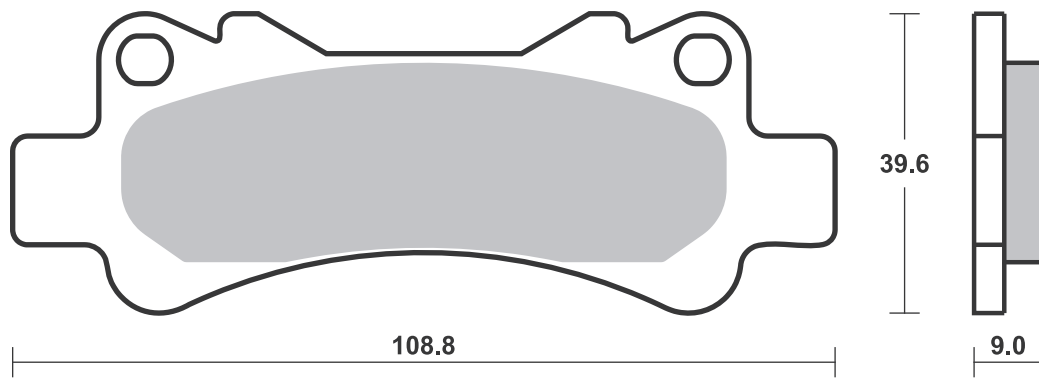

Available compounds

SI • RSI • PSI

SBS 767

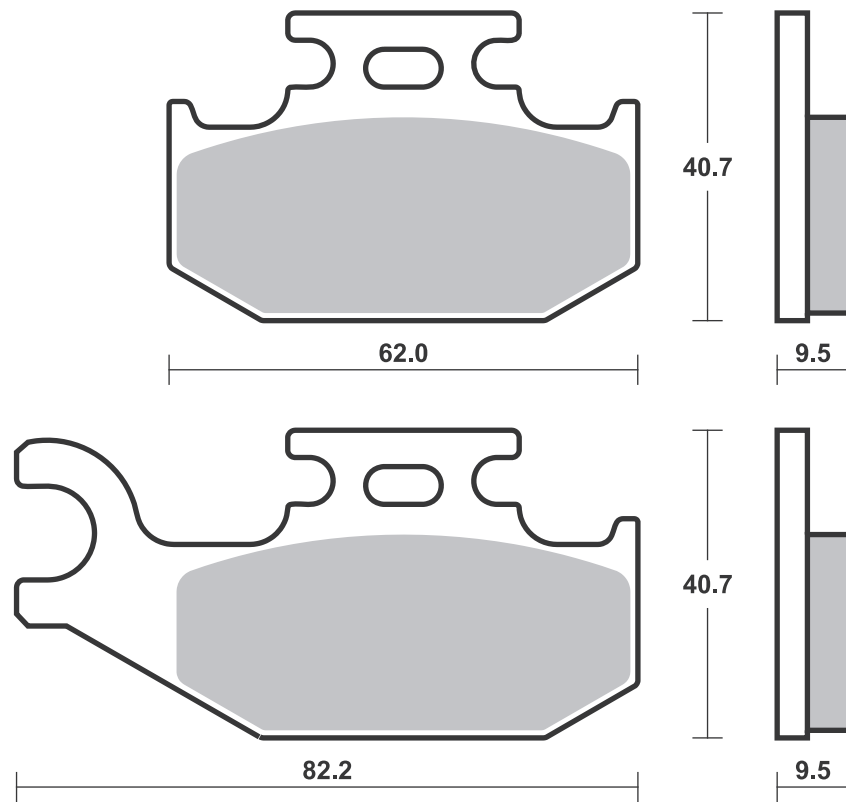



Available compounds

HF • LS

SBS 769

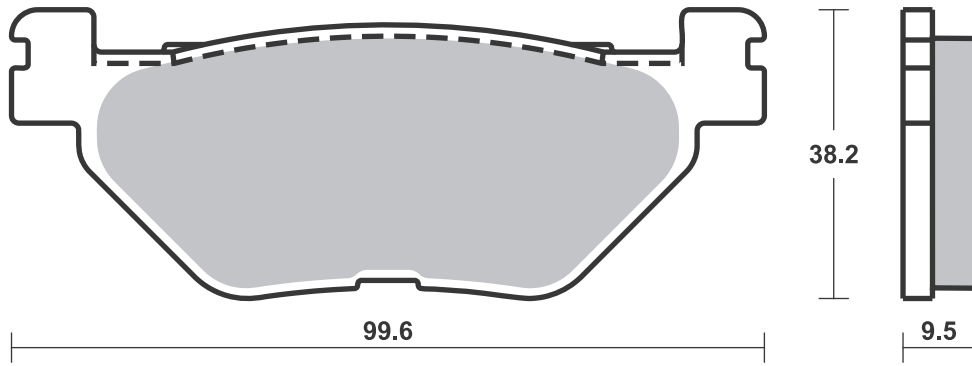

Available compounds

HF • LS

SBS 770

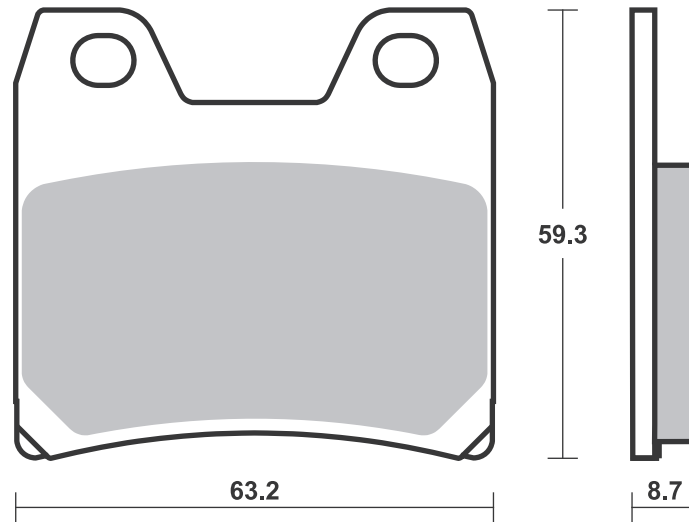



Available compounds

HF • HS • RQ

SBS 771

1 set = 6 pcs.

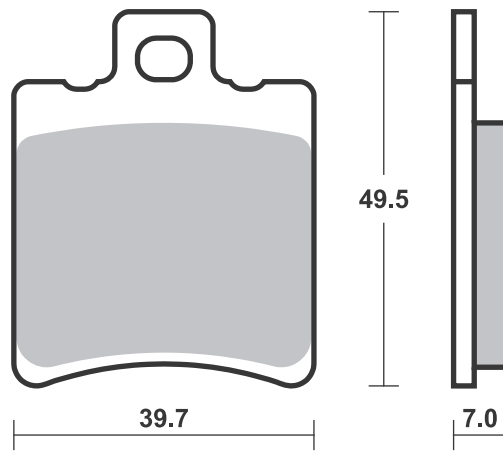

Available compounds

HF

SBS 772

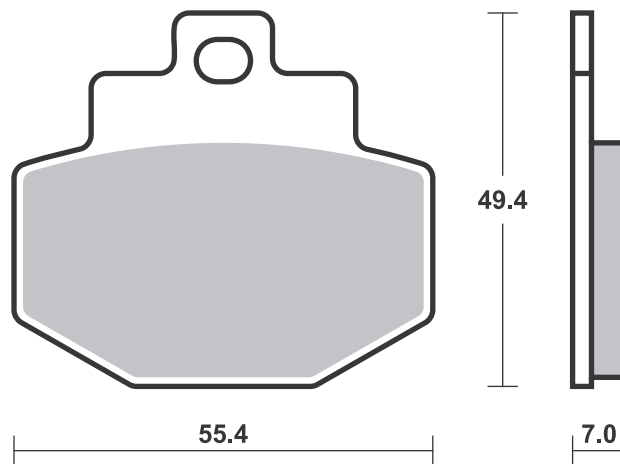

Available compounds

HF

SBS 773

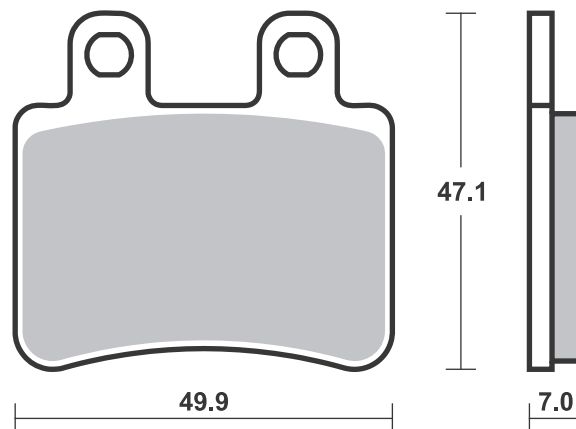





Available compounds

HF

SBS 774

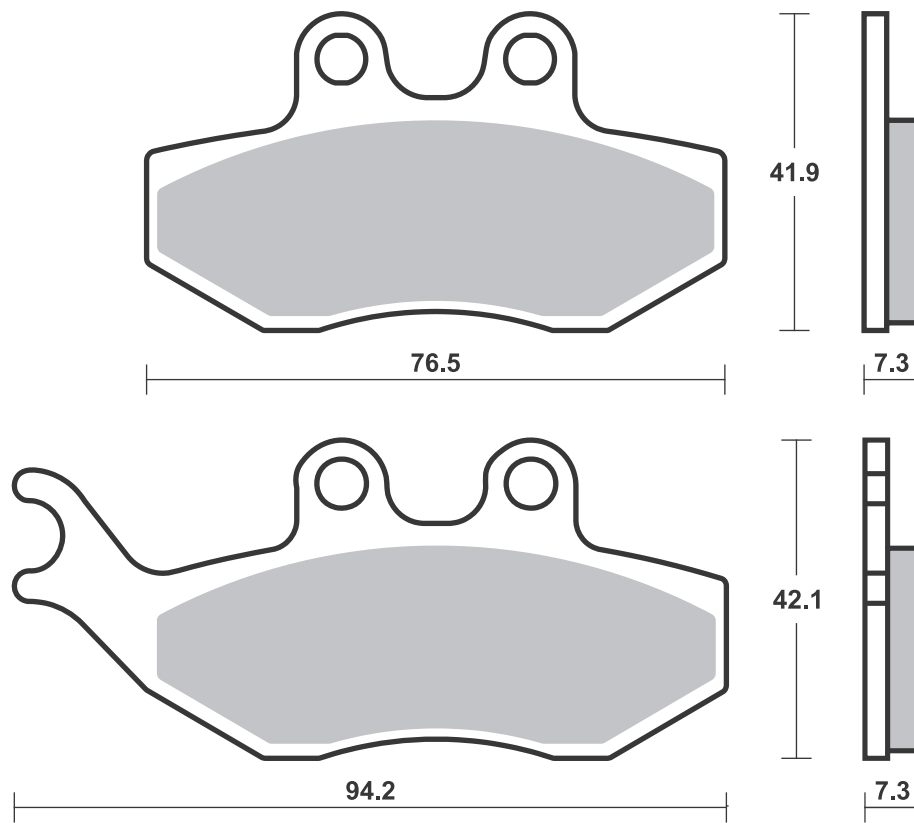

Available compounds

HF • SI • RSI

SBS 775

1 set = 4 pcs.

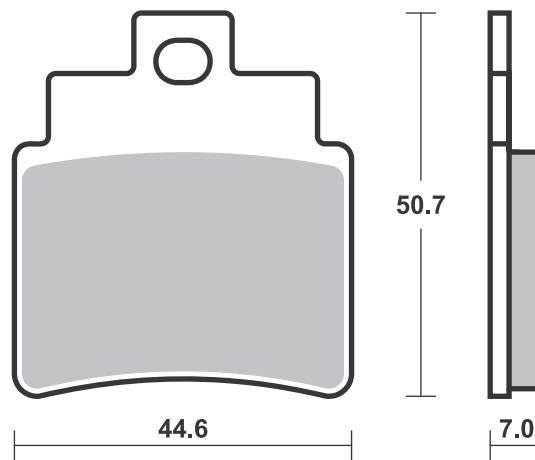

**BRAKING**

Rear cross (1 piston)

**FANTIC**

XEF	125 Competition	22-22	<b>HF</b>
XMF	125 Competition	22-22	<b>HF</b>

**HONDA**

CR	125 R	02-07	<b>RSI</b>
CRE	125	02-07	<b>SI</b>
CRE	125 RR	11-11	<b>SI</b>
CRF	150 R	07-21	<b>RSI</b>
CR	250 R	02-07	<b>RSI</b>
CRE	250	02-07	<b>SI</b>
CRF	250 R	04-22	<b>RSI</b>
CRF	250 X	04-19	<b>SI</b>
CRE	450 F	02-06	<b>SI</b>
CRF	450 L	19-21	<b>RSI</b>
CRF	450 R	02-22	<b>RSI</b>
CRF	450 R-S	22-22	<b>RSI</b>
CRF	450 RWE	19-22	<b>RSI</b>
CRF	450 RX	17-22	<b>SI</b>
CRF	450 X	05-22	<b>SI</b>

**TM**

MX	85	13-20	<b>RSI</b>	<b>RSI</b>
SM	85	18-19	<b>RSI</b>	<b>RSI</b>

**BMW**

R	850 R	03-07	<b>HS</b>
R	1100 S With Integral ABS	01-05	<b>HS</b>
R	1150 GS (Brembo cal.)	02-05	<b>HS</b>
R	1150 R	01-06	<b>HS</b>
R	1150 R Rockster	03-05	<b>HS</b>
R	1150 RS	01-04	<b>HS</b>
K	1200 LT With Integral ABS	01-08	<b>HS</b>
K	1200 R	05-08	<b>HS</b>
K	1200 R Sport	05-07	<b>HS</b>
R	1200 C Classic	03-04	<b>HS</b>
R	1200 C Independent	03-04	<b>HS</b>
R	1200 C Montauk	02-04	<b>HS</b>
R	1200 CL	03-04	<b>HS</b>
R	1200 R	07-14	<b>HS</b>
K	1300 R	09-15	<b>SP</b>
K	1300 R Dynamic	11-15	<b>SP</b>
K	1600 B	17-22	<b>HS</b>
K	1600 Grand America	18-22	<b>HS</b>
K	1600 GT	11-22	<b>HS</b>
K	1600 GTL	11-22	<b>HS</b>

Available compounds

HF • CS • SI • RSI

SBS 777

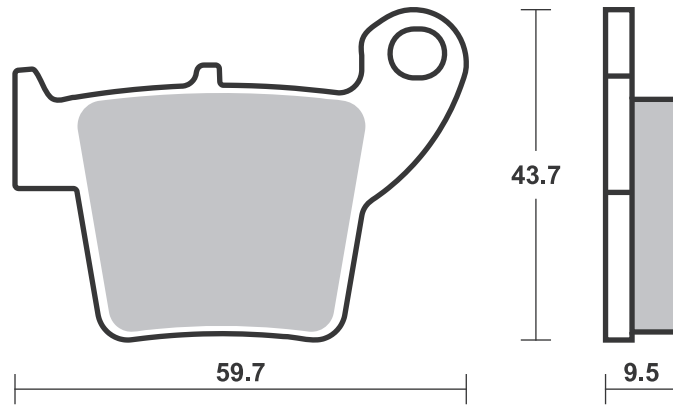
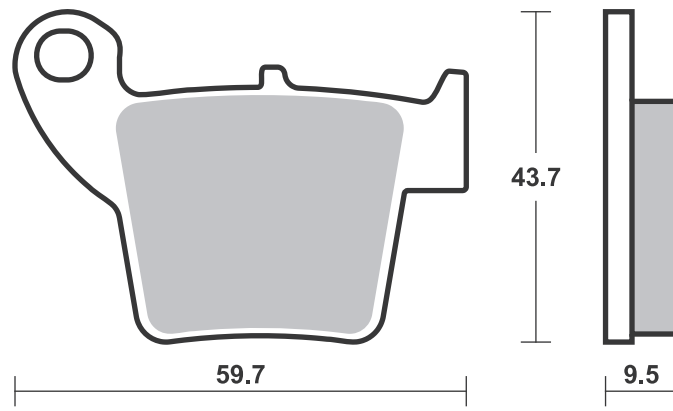

Available compounds

HF • HS • SP • RST

SBS 778

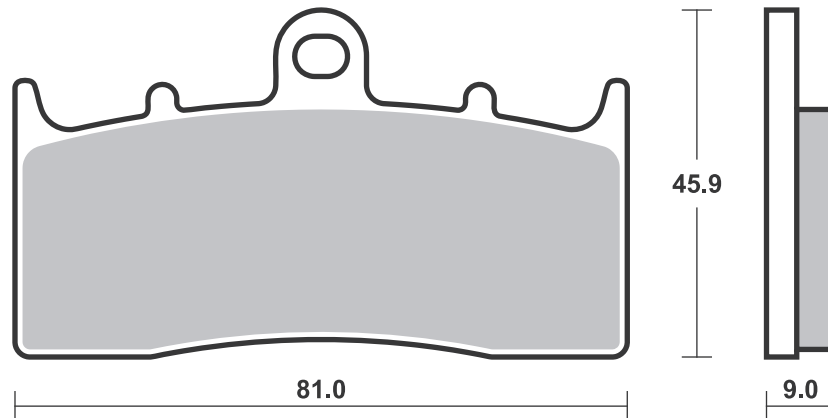



Available compounds

DC

SBS 779

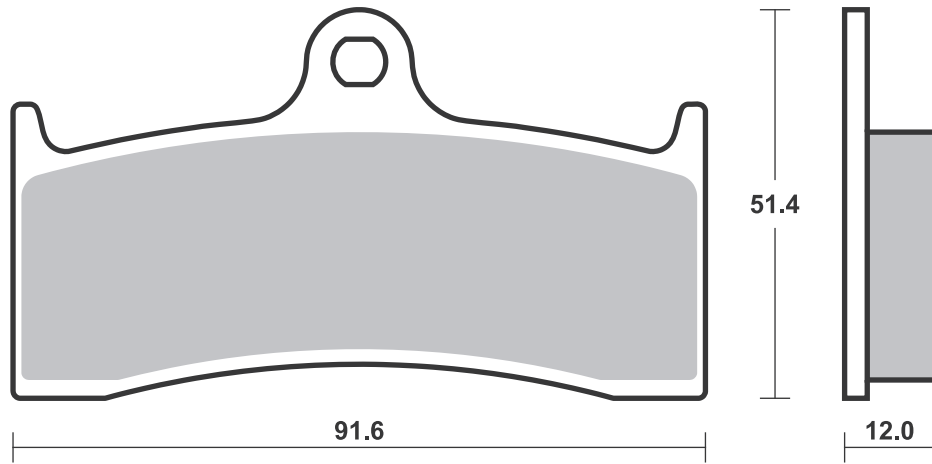

Available compounds

HF

SBS 780

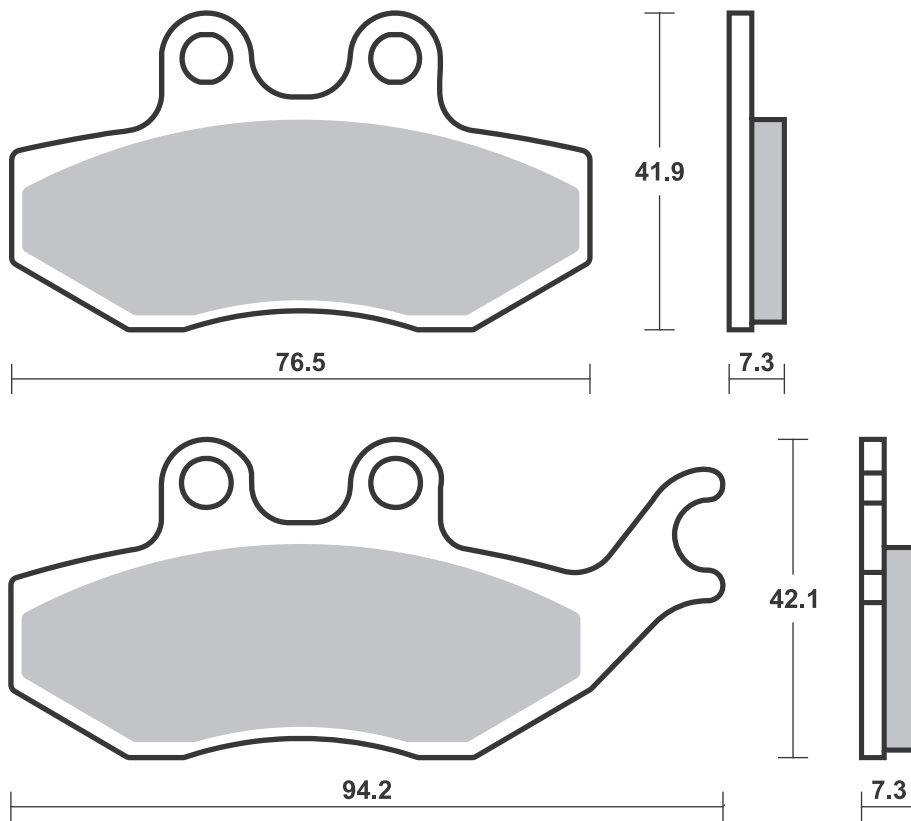

# Applications

## SBS 782 Recommended compound



INDIAN			
1800 Chief	15- 18	<b>H.HS</b>	
1800 Chief Classic	14- 18	<b>H.HS</b>	
1800 Chief Dark Horse	15- 19	<b>H.HS</b>	
1800 Chief Vintage	14- 19	<b>H.HS</b>	
1800 Chieftain	14- 18	<b>H.HS</b>	
1800 Chieftain Classic	15- 18	<b>H.HS</b>	
1800 Chieftain Dark Horse	15- 18	<b>H.HS</b>	
1800 Chieftain Limited	15- 18	<b>H.HS</b>	
1800 Dark Horse	16- 18	<b>H.HS</b>	
1800 Roadmaster	15- 19	<b>H.HS</b>	
1800 Roadmaster Classic	15- 18	<b>H.HS</b>	
1800 Roadmaster Elite	15- 18	<b>H.HS</b>	
1800 Springfield	16- 19	<b>H.HS</b>	
1800 Springfield Dark Horse	15- 20	<b>H.HS</b>	

### KAWASAKI

Z 800	13- 16	<b>HS</b>	
Z 800 ABS	13- 16	<b>HS</b>	
Z 800 e ABS	13- 16	<b>HS</b>	
Z 900	17- 21	<b>HS</b>	
Z 900 Performance	22- 22	<b>SP</b>	
ZX-9R 900 Ninja	02- 03	<b>HS</b>	



MORIWAKI			
MD 250	09- 09	<b>DC</b>	

### SUZUKI

GSX-S 750	17- 19	<b>HS</b>	
1340 B-King	08- 14	<b>HS</b>	

### TRIUMPH

675 Daytona	06- 08	<b>HS</b>	
675 Street Triple R	09- 17	<b>HS</b>	
675 Street Triple RX	15- 16	<b>HS</b>	
1050 Speed Triple	05- 07	<b>HS</b>	
1050 Tiger	07- 13	<b>HS</b>	
1050 Tiger SE	09- 13	<b>HS</b>	
1050 Tiger Sport	15- 19	<b>HS</b>	

### VICTORY

1634 Hammer	08- 08	<b>H.HS</b>	
1634 Kingpin			
all models	08- 12	<b>H.HS</b>	
1634 Vegas	08- 17	<b>H.HS</b>	
1634 Vegas 8-Ball	08- 17	<b>H.HS</b>	
1634 Vegas Jackpot	08- 08	<b>H.HS</b>	
1731 Boardwalk	13- 15	<b>H.HS</b>	
1731 Cross Country	10- 17	<b>H.HS</b>	
1731 Cross Country 8-Ball	14- 16	<b>H.HS</b>	
1731 Cross Country Tour	12- 17	<b>H.HS</b>	
1731 Cross Roads	10- 12	<b>H.HS</b>	



VICTORY			
1731 Cross Roads 8-Ball	14- 14	<b>H.HS</b>	
1731 Cross Roads Classic	14- 14	<b>H.HS</b>	
1731 Gunner	15- 17	<b>H.HS</b>	
1731 Hammer	09- 11	<b>H.HS</b>	
1731 Hammer 8-Ball	10- 16	<b>H.HS</b>	
1731 Hammer S	09- 17	<b>H.HS</b>	
1731 Hard-Ball	12- 13	<b>H.HS</b>	
1731 High-Ball	12- 17	<b>H.HS</b>	
1731 Jackpot	10- 16	<b>H.HS</b>	
1731 Judge	13- 17	<b>H.HS</b>	
1731 Kingpin	10- 12	<b>H.HS</b>	
1731 Kingpin 8-Ball	10- 11	<b>H.HS</b>	
1731 Magnum	15- 17	<b>H.HS</b>	
1731 Magnum X-1	15- 17	<b>H.HS</b>	
1731 Vegas	10- 17	<b>H.HS</b>	
1731 Vegas 8-Ball	10- 17	<b>H.HS</b>	
1731 Vegas Jackpot	09- 09	<b>H.HS</b>	

## SBS 783 Recommended compound



GAS GAS			
MC 65	21- 22	<b>RSI</b>	<b>RSI</b>

### HUSQVARNA

CR 65	12- 13	<b>RSI</b>	
TC 65	17- 22	<b>RSI</b>	<b>RSI</b>

### KTM

SX 65	02- 08	<b>RSI</b>	
SX 65	09- 22	<b>RSI</b>	<b>RSI</b>
SX 85	04- 11	<b>RSI</b>	<b>RSI</b>
SX 85	11- 11	<b>RSI</b>	

Available compounds

HF • HS • SP • DC • RST • H.HF • H.CT • H.HS

SBS 782

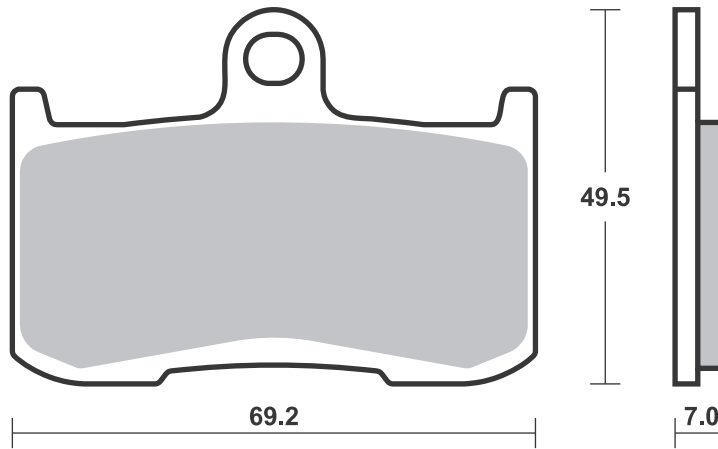

HF / HS / SP - Th. 7.0  
RST / DC - Th. 8.3

Available compounds

CS • SI • RSI

SBS 783

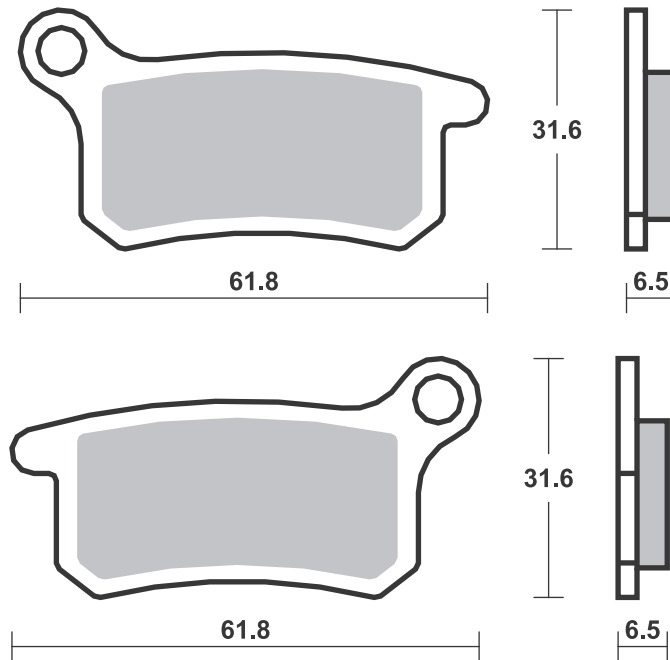

Brake Pad 1:1 Drawings,  
Compounds, Fitments





Available compounds

**HF**

**SBS 784**

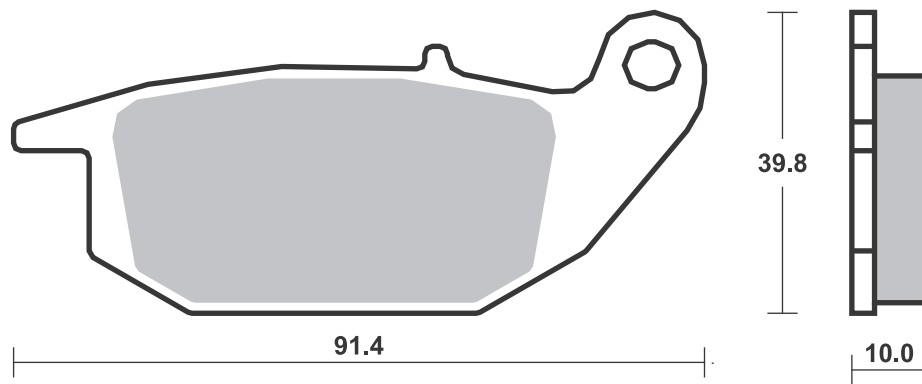
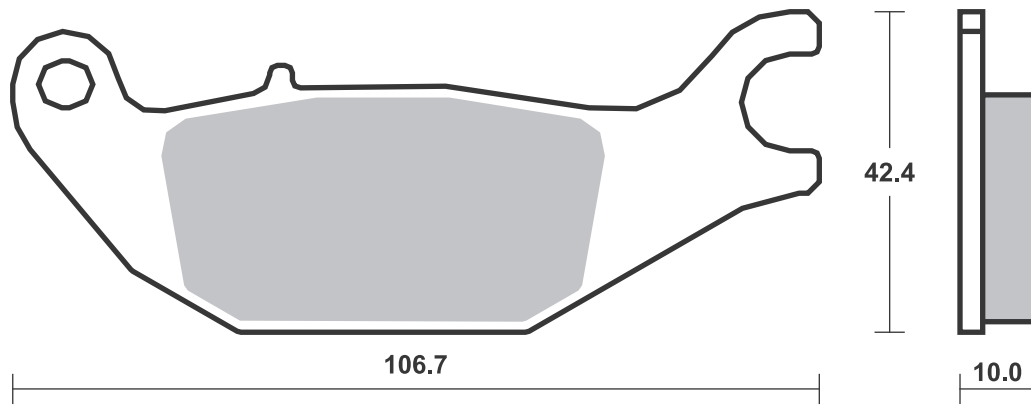

Available compounds

**HS • DC**

**SBS 785**

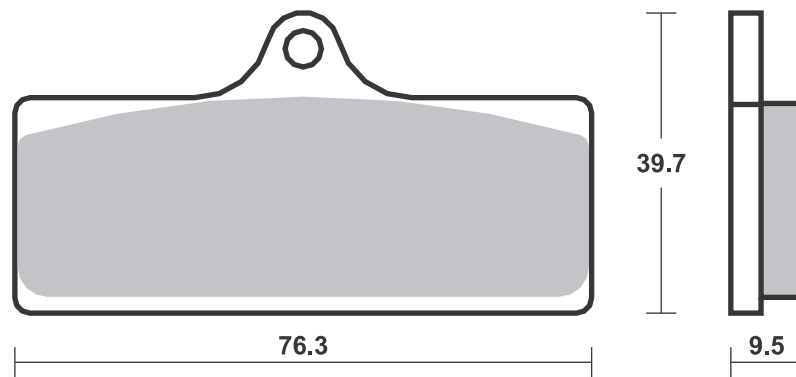

# Applications

## SBS 787 Recommended compound



<b>POLARIS</b>			
325 Xpedition	02-02		<b>ATS</b>
330 ATP	06-05		<b>ATS</b>
330 E Trail			
Blazer	08-12		<b>ATS</b>
330 Magnum			
2x4, 4x4	03-13		<b>ATS</b>
450 Sportsman	06-09		<b>ATS</b>
500 E Scrambler			
2x4, 4x4	08-11		<b>ATS</b>
500 Magnum			
2x4, 4x4	02-07		<b>ATS</b>
500 Predator e	06-13		<b>ATS</b>
500 Sportsman			
HO (to			
15.12.2008)	03-08		<b>ATS</b>
600 Sportsman	03-06		<b>ATS</b>
700 Sportsman	02-09		<b>ATS</b>



<b>POLARIS</b>			
700 Sportsman			
MV 700	05-06		<b>ATS</b>
800 Sportsman			
(to 15.12.2008)	05-08		<b>ATS</b>

## SBS 788 Recommended compound



<b>DERBI</b>			
659 Mulhacen	05-05		<b>HS</b>

<b>KAWASAKI</b>			
ZX-6RR	600 Ninja	03-06	<b>HS</b>
ZX-6R	636 Ninja	03-06	<b>HS</b>
ZX-10R	1000 Ninja	04-07	<b>HS</b>
ZX-12R	1200 Ninja	04-06	<b>HS</b>
VN	1600 Mean Streak	05-05	<b>HS</b>

<b>SUZUKI</b>			
GSX-R	1000	03-03	<b>HS</b>
M95	1600 Boulevard	05-07	<b>HS</b>

## SBS 789 Recommended compound



<b>SUZUKI</b>			
C90	1500 Boulevard	05-18	<b>LS</b>
VL	1500 Intruder LC	02-02	<b>LS</b>

Brake Pad 1:1 Drawings, Compounds, Fitments

Available compounds

SI • RSI • ATS

SBS 787

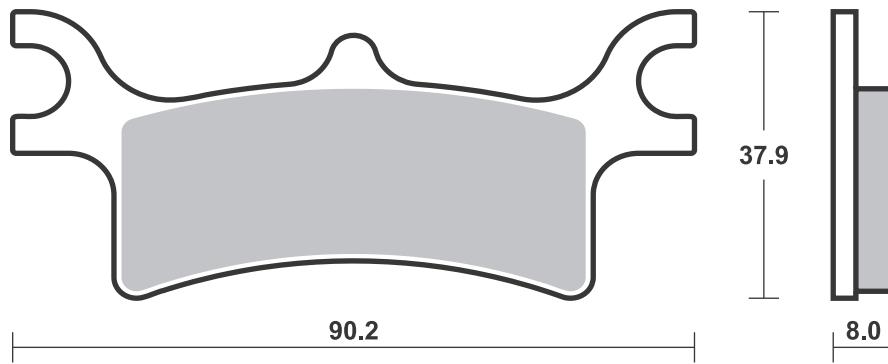

Available compounds

HS • SP • DC • RST • DS-1

SBS 788

1 set = 4 pcs.

HS / SP - Th. 7.9  
 RST / DC / DS - Th. 9.5

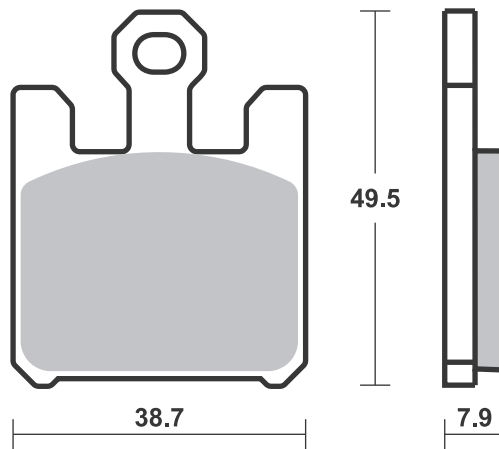

Available compounds

HF • LS

SBS 789

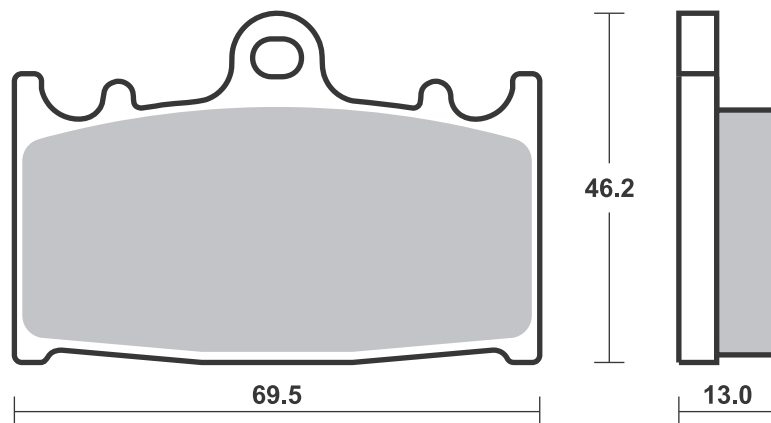



<b>APRILIA</b>			
MXV	450	09-13	<b>RSI</b>
RXV	450	06-13	<b>SI</b>
SXV	450	06-13	<b>RSI</b>
SXV	450 Van den Bosch Rep.	08-10	<b>RSI</b>
RXV	550	06-13	<b>SI</b>
SXV	550	06-13	<b>RSI</b>
SXV	550 Van den Bosch Rep.	08-10	<b>RSI</b>

<b>BETA</b>			
RR	125	18-19	<b>SI</b>
RR	250	05-09	<b>SI</b>
	300 Crosstrainer	15-15	<b>SI</b>
RR	300	13-19	<b>SI</b>
RR	350 Efi	15-15	<b>SI</b>
RR	350 Efi Racing	15-15	<b>SI</b>
RR	350 Enduro	12-14	<b>SI</b>
RR	390	15-19	<b>SI</b>
RR	400 Enduro	05-05	<b>SI</b>
RR	430	15-19	<b>SI</b>
RR	430 Racing	15-19	<b>SI</b>
RR	450 Cross Country	12-12	<b>SI</b>
RR	450 Enduro	05-07	<b>SI</b>
RR	480	15-19	<b>SI</b>
RR	480 Racing	15-19	<b>SI</b>
RR	498 Enduro	12-14	<b>SI</b>
RR	525 Enduro	05-13	<b>SI</b>

<b>BIMOTA</b>			
BBX	300 Enduro	12-12	<b>SI</b>

<b>CCM</b>			
	450 MX	08-10	<b>RSI</b>

<b>FANTIC</b>			
XE	125	22-22	<b>SI</b>
XX	125	20-22	<b>RSI</b>
XEF	250	22-22	<b>SI</b>
XX	250	22-22	<b>RSI</b>
XXF	250	22-22	<b>RSI</b>
	450 Rally	22-22	<b>SI</b>
XEF	450	22-22	<b>SI</b>
XXF	450	22-22	<b>RSI</b>

<b>GAS GAS</b>			
EC	200	17-17	<b>SI</b>
XC	200	18-19	<b>SI</b>
EC	250	12-20	<b>SI</b>
EC	250 Enduro GP 18	18-19	<b>SI</b>
XC	250	17-19	<b>SI</b>
EC	300	12-20	<b>SI</b>
EC	300 Enduro GP 18	18-19	<b>SI</b>
XC	300	18-19	<b>SI</b>

<b>KAWASAKI</b>			
KX	250	19-22	<b>RSI</b>
KX	250 F	04-18	<b>RSI</b>
KX	250 X	21-22	<b>SI</b>
KLX	450 R	07-19	<b>SI</b>
KX	450	19-22	<b>RSI</b>
KX	450 F	06-18	<b>RSI</b>
KX	450 X	21-22	<b>SI</b>

<b>SHERCO</b>			
SE	250 2.5i Enduro	06-11	<b>SI</b>
SX	250 2.5i-F	09-11	<b>RSI</b>



<b>SHERCO</b>			
SE	300 3.0i-F	10-11	<b>SI</b>
SE	450 4.5i Enduro	05-11	<b>SI</b>
SM	450 4.5i		
	Supermotard	06-06	<b>RSI</b>
SE	510 5.1i Enduro	06-11	<b>SI</b>

<b>SUZUKI</b>			
RM-Z	250	04-22	<b>RSI</b>
RMX	450 Z	10-18	<b>SI</b>
RM-Z	450	05-22	<b>RSI</b>

<b>TM</b>			
EN	125 Enduro	05-17	<b>SI</b>
MX	125	05-20	<b>RSI</b>
EN	250 Enduro	05-15	<b>SI</b>
EN	250 F Enduro	05-17	<b>SI</b>
MX	250	05-20	<b>RSI</b>
MX	250 F	05-20	<b>RSI</b>
EN	300 Enduro	05-05	<b>SI</b>
FT	300	17-19	<b>RSI</b>
MX	300	05-20	<b>RSI</b>
EN	450 F Enduro	05-17	<b>SI</b>
FT	450 Fi	17-19	<b>RSI</b>
MX	450 F	05-20	<b>RSI</b>
EN	530 F Enduro	05-05	<b>SI</b>
FT	530 Fi	17-19	<b>RSI</b>
MX	530 F	05-20	<b>RSI</b>

<b>YAMAHA</b>			
YZ	125	03-21	<b>RSI</b>
WR	250 F	03-13	<b>SI</b>
WR	250 F Efi	15-21	<b>SI</b>
WR	250 F Enduro GP	18-18	<b>SI</b>
WR	250 R	08-15	<b>LS</b>
WR	250 X	08-16	<b>LS</b>
YZ	250	03-21	<b>RSI</b>
YZ	250 F	03-20	<b>RSI</b>
YZ	250 FX	15-21	<b>SI</b>
YZ	250 X	16-17	<b>SI</b>
WR	450 F	03-15	<b>SI</b>
WR	450 F Efi	16-21	<b>SI</b>
WR	450 F Enduro GP	18-18	<b>SI</b>
YZ	450 F	03-19	<b>RSI</b>
YZ	450 FX	16-22	<b>SI</b>

<b>ZERO</b>			
DS	ZF11.4	13-13	<b>LS</b>
DS	ZF8.5	13-13	<b>LS</b>
FX	ZF2.8	13-13	<b>LS</b>
FX	ZF5.7	13-13	<b>LS</b>
MX	ZF2.8	13-13	<b>RSI</b>
MX	ZF5.7	13-13	<b>RSI</b>
S	ZF11.4	13-13	<b>LS</b>
S	ZF8.5	13-13	<b>LS</b>
XU	ZF2.8	13-13	<b>LS</b>
XU	ZF5.7	13-13	<b>LS</b>

Available compounds

**HF • LS • CS • SI • RSI**

**SBS 790**

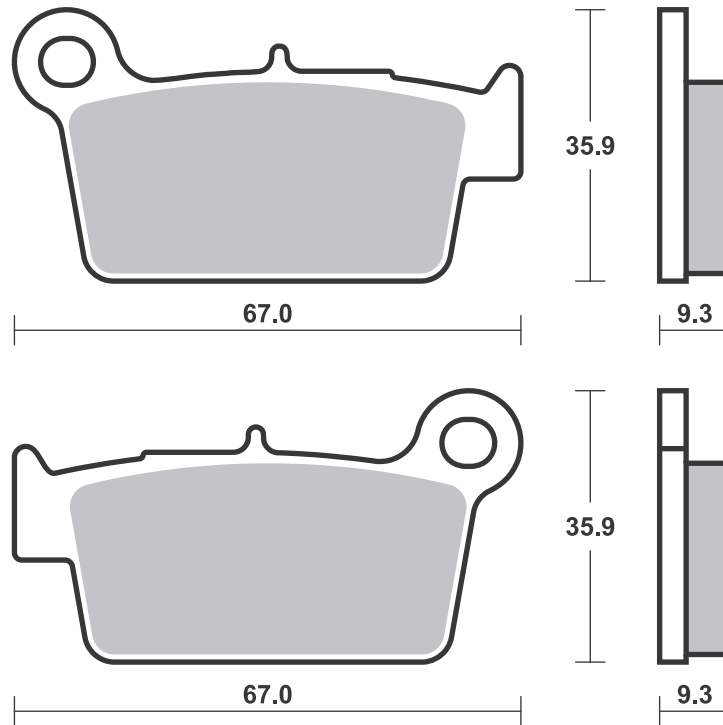



<b>BMW</b>			
G	450 SMR	09-10	<b>RSI</b>
G	450 X	08-10	<b>SI</b>

**BREMBO RACING CALIPERS**

Off Road XQ21390, PF 26

**GAS GAS**

MC	85	21-22	<b>RSI</b>
MC	125	21-22	<b>RSI</b>
EC	200 Ranger		
	Enduro	19-19	<b>SI</b>
EC	250	21-22	<b>SI</b>
EC	250 F	21-22	<b>SI</b>
MC	250	21-22	<b>RSI</b>
MC	250 F	21-22	<b>RSI</b>
EC	300	21-22	<b>SI</b>
EC	300 Ranger		
	Enduro	19-19	<b>SI</b>
EC	350 F	21-22	<b>SI</b>
MC	350 F	22-22	<b>RSI</b>
MC	450 F	21-22	<b>RSI</b>

**HUSABERG**

TE	125	13-13	<b>SI</b>
FE	250	13-13	<b>SI</b>
TE	250	11-13	<b>SI</b>
TE	300	11-13	<b>SI</b>
FE	350	13-13	<b>SI</b>
FE	390	10-13	<b>SI</b>
FE	450	09-13	<b>SI</b>
FE	501	13-13	<b>SI</b>
FE	570	09-13	<b>SI</b>

**HUSQVARNA**

TC	85	21-22	<b>RSI</b>
CR	125	05-13	<b>RSI</b>
TC	125	14-22	<b>RSI</b>
TE	125	14-16	<b>SI</b>
TX	125	17-19	<b>SI</b>
TE	150 i	20-22	<b>SI</b>
CR	250	05-05	<b>RSI</b>
FC	250	14-22	<b>RSI</b>
FE	250	14-22	<b>SI</b>
TC	250	04-22	<b>RSI</b>
TE	250	14-18	<b>SI</b>
TE	250 4T	10-13	<b>SI</b>
TE	250 i	20-22	<b>SI</b>
TC	300	14-15	<b>RSI</b>
TE	300	14-19	<b>SI</b>
TE	300 i	18-22	<b>SI</b>
WR	300	09-13	<b>SI</b>
TE	310 4T	10-13	<b>SI</b>
FC	350	14-22	<b>RSI</b>
FE	350	14-22	<b>SI</b>
SMR	449	11-13	<b>RSI</b>
TC	449	11-13	<b>RSI</b>
TE	449	11-13	<b>SI</b>
FC	450	14-22	<b>RSI</b>
FE	450	14-22	<b>SI</b>
FS	450	15-22	<b>RSI</b>
SM	450 R	06-13	<b>RSI</b>
SM	450 RR	06-10	<b>RSI</b>
TC	450	04-10	<b>RSI</b>
TE	450	14-14	<b>SI</b>
FE	501	14-22	<b>SI</b>
SM	510 Centennial	06-06	<b>RSI</b>
SM	510 R	06-10	<b>RSI</b>



<b>HUSQVARNA</b>			
TC	510	04-10	<b>RSI</b>
SMR	511	11-13	<b>RSI</b>
TE	511	11-14	<b>SI</b>
SM	610 ie	07-10	<b>RSI</b>
SM	630	10-10	<b>HF</b>
TE	630	10-13	<b>HF</b>
TE	630	14-14	<b>SI</b>
STR	650 CRC	07-07	<b>HF</b>

**KTM**

SX	85	21-22	<b>RSI</b>
SX	85 (19"/		
	16" wheels)	21-22	<b>RSI</b>
EXC	125 Enduro	04-15	<b>SI</b>
SX	125	04-22	<b>RSI</b>
XC	125	19-22	<b>RSI</b>
SX	144	07-08	<b>RSI</b>
EXC	150 TPI	20-22	<b>SI</b>
SX	150	09-22	<b>RSI</b>
XC	150	10-19	<b>RSI</b>
XC	150 TPI	20-22	<b>RSI</b>
EXC	200 Enduro	04-16	<b>SI</b>
SX	200	03-04	<b>RSI</b>
XC	200	06-09	<b>RSI</b>
XC-W	200	06-16	<b>RSI</b>
EXC	250 Enduro	04-08	<b>SI</b>
EXC	250 Enduro 4T	04-06	<b>SI</b>
EXC	250 TPI	18-22	<b>SI</b>
EXC-F	250	07-22	<b>SI</b>
SX	250	03-22	<b>RSI</b>
SX-F	250	06-22	<b>RSI</b>
XC	250	06-14	<b>RSI</b>
XC	250 TPI	19-22	<b>RSI</b>
XC-F	250	10-22	<b>RSI</b>
XC-W	250	08-17	<b>RSI</b>
EXC	300 Enduro	04-08	<b>SI</b>
EXC	300 TPI	18-22	<b>SI</b>
XC	300	06-14	<b>RSI</b>
XC	300 TPI	19-22	<b>RSI</b>
XC-W	300	06-08	<b>RSI</b>
EXC-F	350	11-22	<b>SI</b>
SX-F	350	11-22	<b>RSI</b>
XC-F	350	12-22	<b>RSI</b>
XCF-W	350	13-17	<b>RSI</b>
EXC	400 Racing	04-07	<b>SI</b>
XC-W	400	07-10	<b>RSI</b>
	450 Rally	19-22	<b>SI</b>
EXC-F	450	04-22	<b>SI</b>
SX	450 SM Factory		
	Replica	04-07	<b>RSI</b>
SX	450 SMR	04-12	<b>RSI</b>
SX	450 SMR	21-22	<b>RSI</b>
SX-F	450	03-22	<b>RSI</b>
XC-F	450	06-22	<b>RSI</b>
XCF-W	450	07-15	<b>RSI</b>
EXC-F	500	12-22	<b>SI</b>
XCF-W	500	12-17	<b>RSI</b>
SX	505 Racing	07-09	<b>RSI</b>
XC-F	505	08-09	<b>RSI</b>
EXC	525 Racing	04-06	<b>SI</b>
SX	525 SMR	04-07	<b>RSI</b>
SX-F	525 Racing	04-06	<b>RSI</b>
XC-F	525	07-07	<b>RSI</b>
XCF-W	525	07-07	<b>RSI</b>
EXC	530 Racing	08-11	<b>SI</b>
XCF-W	530	09-11	<b>RSI</b>
SX	560 SMR	06-07	<b>RSI</b>



<b>SHERCO</b>			
SE-R	125	17-19	<b>SI</b>
SE	250 , R	14-14	<b>SI</b>
SE	250 F, F-R	14-19	<b>SI</b>
SE	250 i/iR	12-13	<b>SI</b>
SE	250 i-F	13-13	<b>SI</b>
SCF-R	300	16-19	<b>SI</b>
SE	300 , R	14-19	<b>SI</b>
SE	300 F, F-R	14-19	<b>SI</b>
SE	300 i/iR	12-13	<b>SI</b>
SE	300 i-F	13-13	<b>SI</b>
SE	450 F, F-R	14-19	<b>SI</b>
SE	450 iR	12-13	<b>SI</b>
SE	510 iR	12-13	<b>SI</b>

**SWM**

	125 Gran Milano		
	Outlaw	20-20	<b>HF</b>
	125 Varez	20-20	<b>HF</b>
RS	125 R	20-20	<b>HF</b>
SM	125 R	20-20	<b>HF</b>
RS	300 R	15-20	<b>SI</b>
	400 Varez	20-20	<b>HF</b>
SM	450 R	15-17	<b>HF</b>
	500 Ace of Spades	20-20	<b>HF</b>
	500 Gran Milano		
	Outlaw	20-20	<b>HF</b>
RS	500 R	15-20	<b>SI</b>
SM	500 R	18-20	<b>HF</b>

Available compounds

HF • CS • SI • RSI

SBS 791

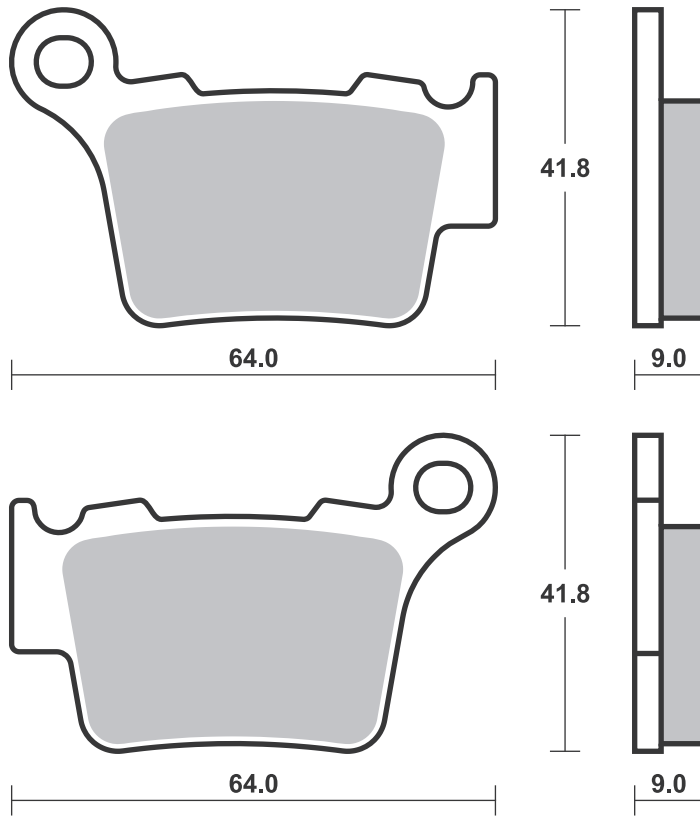





Available compounds

HF

SBS 792

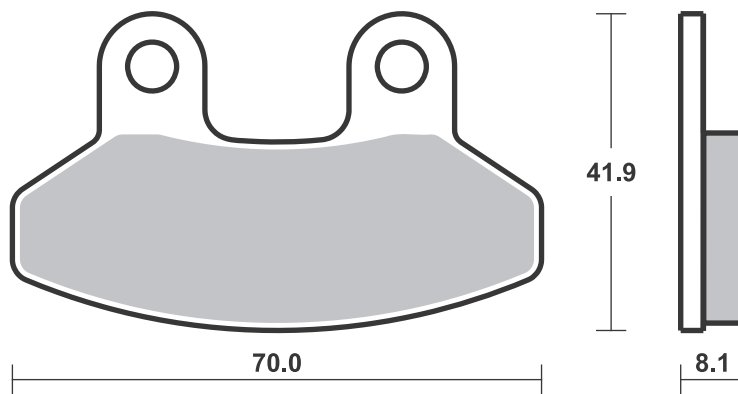

Available compounds

SI • RSI

SBS 794

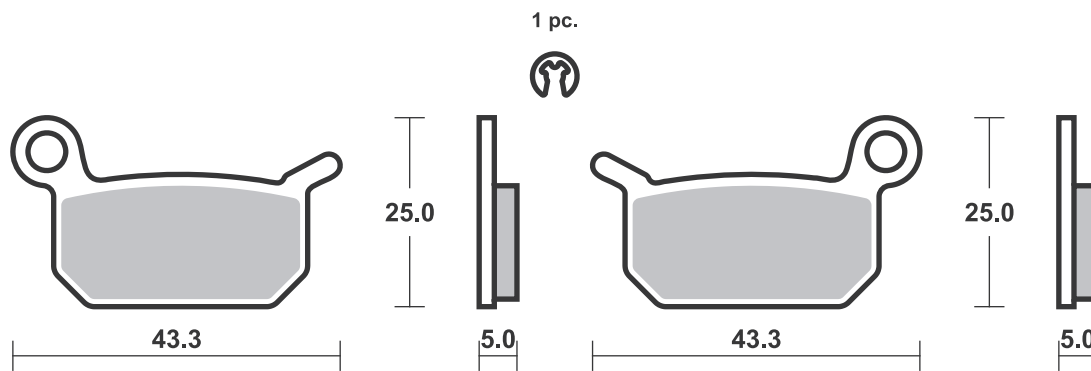

Available compounds

HF • HS

SBS 795

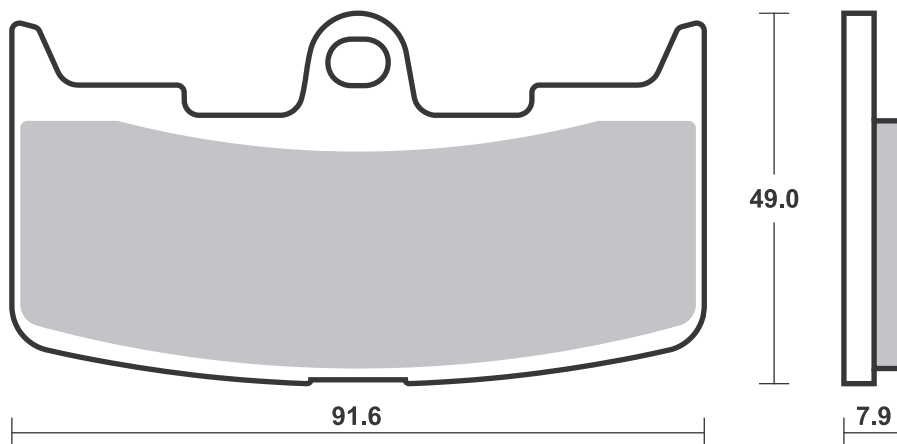



Available compounds

HF • HS • SP • RST

SBS 796

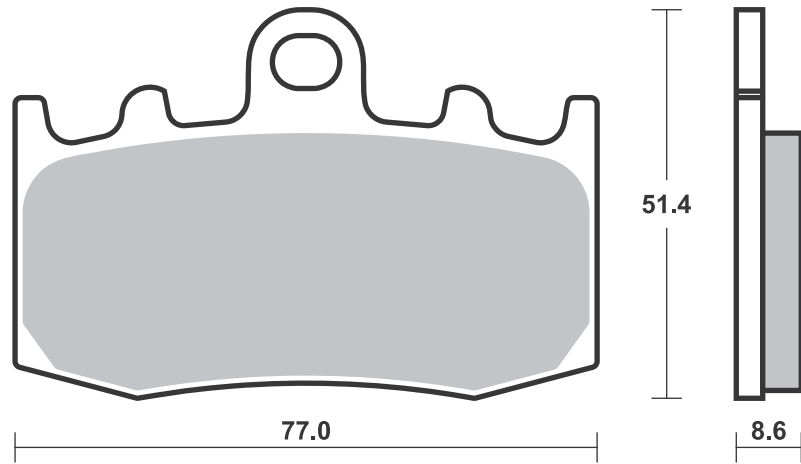

Available compounds

HF • RSI • RST

SBS 797

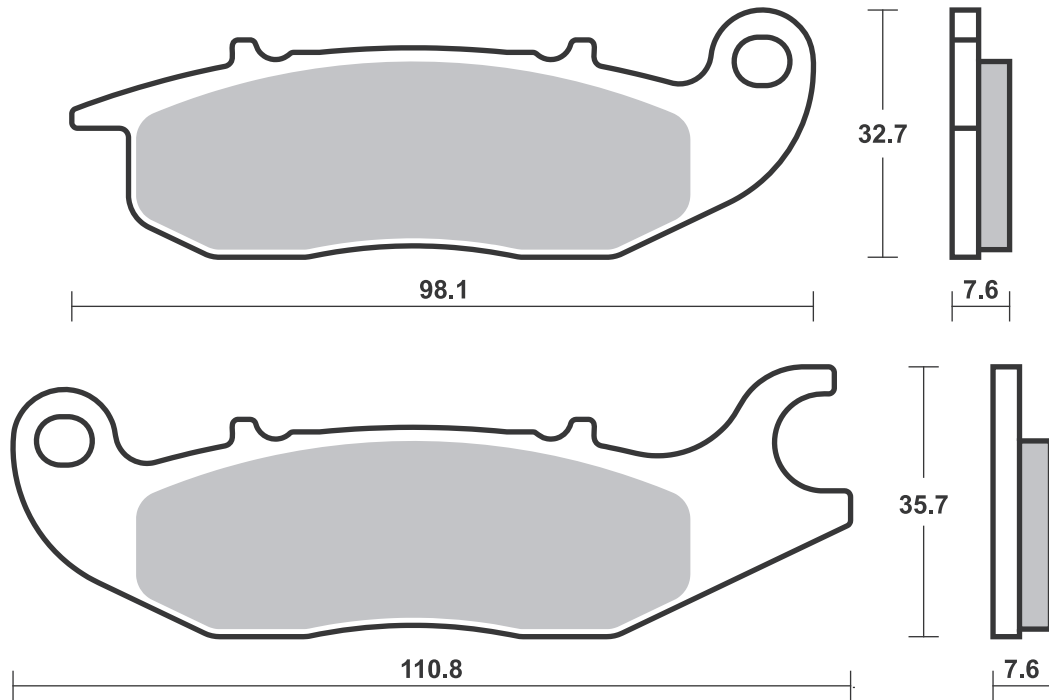

Brake Pad 1:1 Drawings,  
Compounds, Fitments

# Applications

## SBS 798 Recommended compound



### KAWASAKI

KFX	450	07-15	SI
KVF	650 Brute Force		
	4x4	05-11	SI
KVF	650 Prairie	01-03	SI
KFX	700 V-Force	04-13	SI
KSV	700 V-Force	04-11	SI
KVF	700 Prairie	04-13	SI

### SUZUKI

LT-V	700 Quadrunner		
	Twin Peaks	04-06	SI

## SBS 799 Recommended compound



### CF MOTO

	400 C-Force	18-21	SI
	450 C-Force L	16-17	SI
	450 G-Force L	16-17	SI
	500 C-Force HO	18-18	SI
	500 C-Force S	18-21	SI
CF	500 Terralander	13-15	SI
	550 C-Force	16-17	SI
	600 C-Force	19-19	SI
CF	625 Terralander	11-15	SI
CF	800 Terralander	12-14	SI

### GOES

	520 Max	07-12	SI
G	520	07-12	SI
G	525	12-14	SI
G	620	11-14	SI
G	625 A	12-14	SI

### YAMAHA

YFM	660 FWAP 4x4		
	Grizzly	02-08	SI

Available compounds

SI • RSI

SBS 798

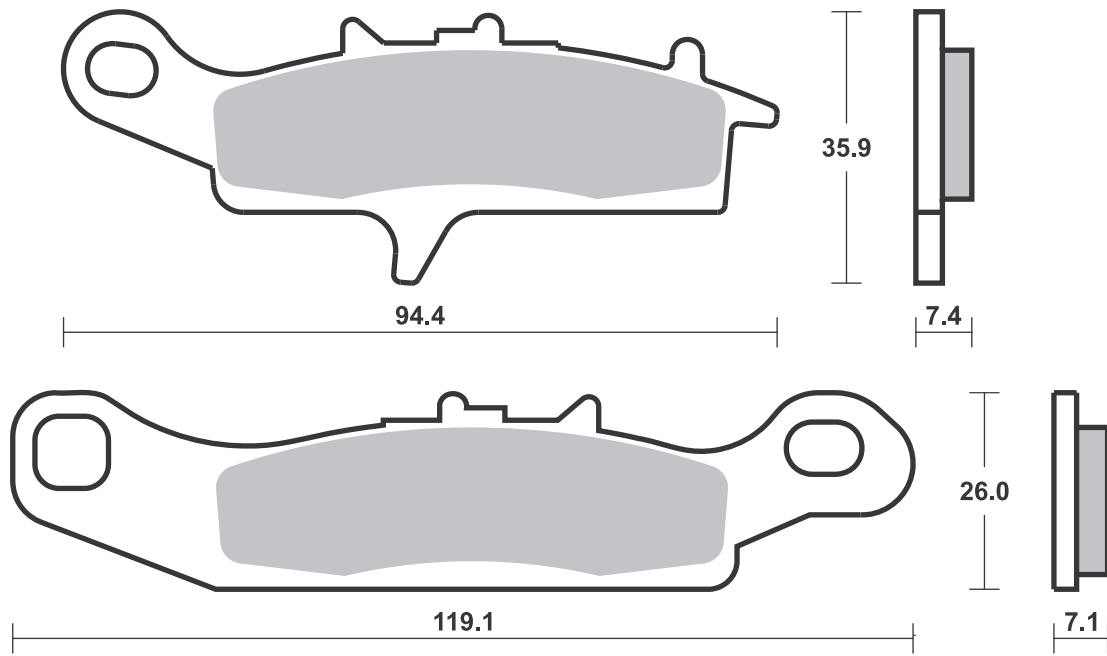

Available compounds

SI • RSI

SBS 799

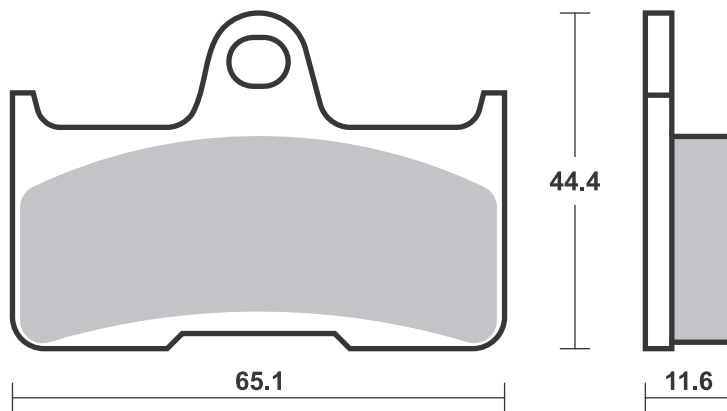



Available compounds

SI • RSI • ATS

SBS 800

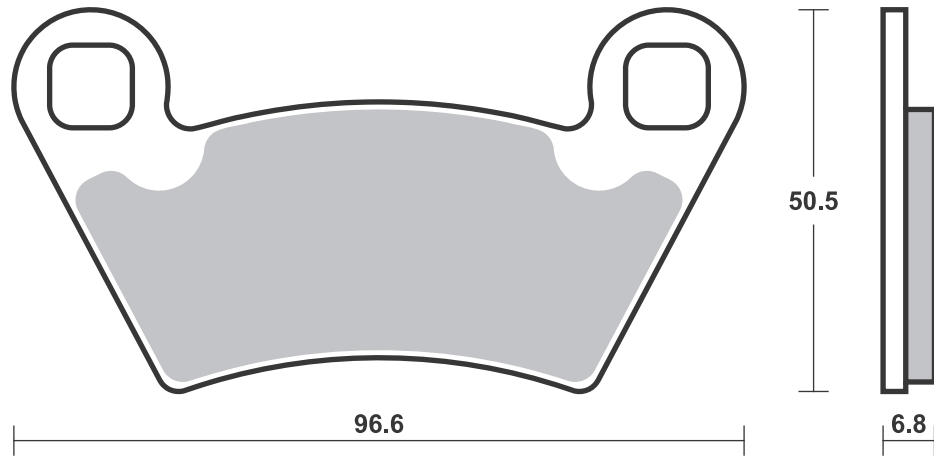

Available compounds

SI • RSI

SBS 801

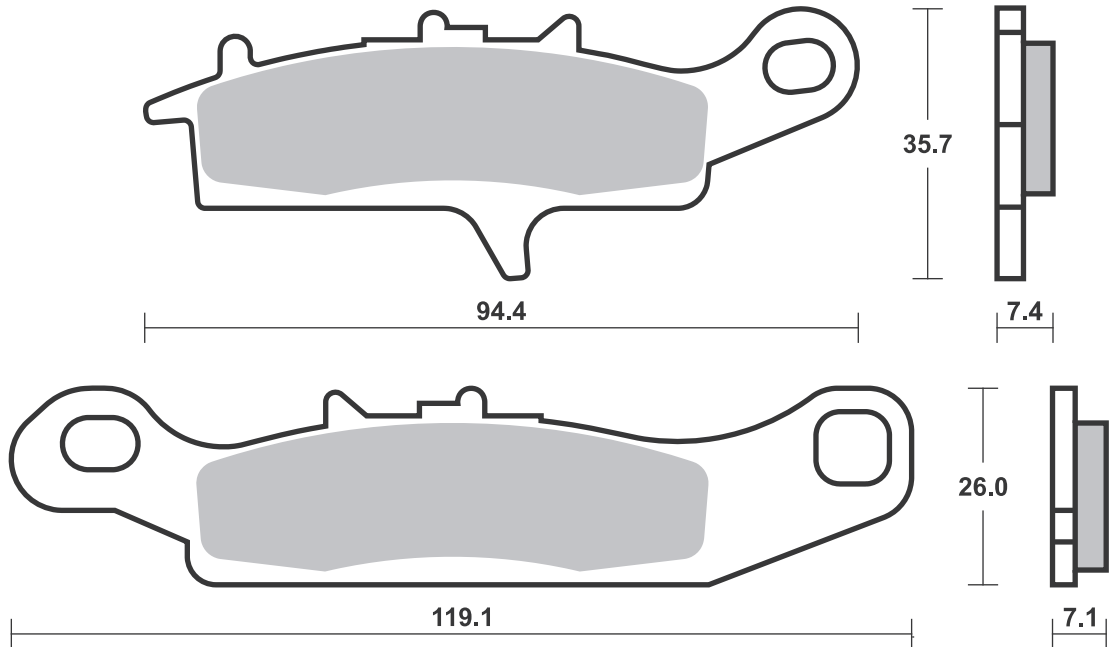

Brake Pad 1:1 Drawings,  
Compounds, Fitments

**SBS 802** Recommended compound

<b>BETA</b>			
80 EVO	09-10	<b>RSI</b>	
80 Rev	08-10	<b>RSI</b>	
125 EVO	09-14	<b>RSI</b>	
125 Rev 3	00-08	<b>RSI</b>	<b>RSI</b>
125 Rev 3	06-08	<b>RSI</b>	
200 EVO	09-14	<b>RSI</b>	
200 Rev 3	06-08	<b>RSI</b>	
250 4-T Rev 3	07-11	<b>RSI</b>	
250 EVO (2-T / 4-T)	09-14	<b>RSI</b>	
250 Rev 3	00-09	<b>RSI</b>	<b>RSI</b>
250 Rev 3	05-09	<b>RSI</b>	
270 Rev 3	00-08	<b>RSI</b>	<b>RSI</b>
270 Rev 3	05-08	<b>RSI</b>	
290 EVO	09-13	<b>RSI</b>	
300 EVO	09-15	<b>RSI</b>	

**GAS GAS**

TX 125 Randone	12-13	<b>RSI</b>	
TXT 125	04-13	<b>RSI</b>	
TXT 200	04-10	<b>RSI</b>	
TXT 250	04-07	<b>RSI</b>	
TXT 280	04-04	<b>RSI</b>	



<b>GAS GAS</b>			
TXT 300	04-06	<b>RSI</b>	
TXT 300 Pro	07-11	<b>RSI</b>	

**HONDA**

250 Cota 4RT	04-16	<b>RSI</b>	
Cota 260 4RT	04-16	<b>RSI</b>	

**MONTESA**

250 Cota 4RT	04-16	<b>RSI</b>	
Cota 260 4RT	04-16	<b>RSI</b>	
360 315R	01-04	<b>RSI</b>	

**OSSA**

TR 125 i	15-15	<b>RSI</b>	
TR 250 i	15-15	<b>RSI</b>	
TR 280 i	10-15	<b>RSI</b>	
TR 280 i Explorer	12-15	<b>RSI</b>	
TR 300 i	15-15	<b>RSI</b>	

**SCORPA**

SY 115 F Trial	06-06	<b>RSI</b>	
125 Twenty Trial	16-18	<b>RSI</b>	



<b>SCORPA</b>			
SY 125 F Trial	06-11	<b>RSI</b>	
250 Twenty Trial	16-18	<b>RSI</b>	
SY 250 F Trial	06-11	<b>RSI</b>	
SY 250 Trial	00-01	<b>RSI</b>	
300 Twenty Trial	16-18	<b>RSI</b>	

**SHERCO**

ST 125 1,25	06-11	<b>RSI</b>	
ST 250 2,5	01-01	<b>RSI</b>	
ST 290 2,9	01-01	<b>RSI</b>	
ST 300	16-19	<b>RSI</b>	
ST 320 3.2F	05-05	<b>RSI</b>	

**TRS**

250 ONE	16-19	<b>RSI</b>	
280 ONE	16-19	<b>RSI</b>	
300 ONE	16-19	<b>RSI</b>	

**SBS 803** Recommended compound

<b>APRILIA</b>			
50 Mini RX	04-04	<b>RSI</b>	

**BETA**

50 ProRace 12/10	04-04	<b>RSI</b>	<b>RSI</b>
------------------	-------	------------	------------

**GAS GAS**

TX 125 Randone	12-13	<b>RSI</b>	
TXT 125	04-13	<b>RSI</b>	
TXT 125 (Formula cal.)	12-13	<b>RSI</b>	
TXT 125 GP	19-22	<b>RSI</b>	
TXT 125 Pro Racing	14-14	<b>RSI</b>	
TXT 125 Pro Replica	13-13	<b>RSI</b>	
TXT 125 Racing	19-22	<b>RSI</b>	
TXT 200	04-10	<b>RSI</b>	
TXT 250	04-07	<b>RSI</b>	
TXT 250 (Formula cal.)	12-13	<b>RSI</b>	
TXT 250 GP	19-22	<b>RSI</b>	
TXT 250 Pro Racing	14-19	<b>RSI</b>	
TXT 250 Pro Replica	13-14	<b>RSI</b>	
TXT 250 Racing	19-22	<b>RSI</b>	
TXT 280	04-04	<b>RSI</b>	
TXT 280 (Formula cal.)	12-12	<b>RSI</b>	
TXT 280 GP	19-22	<b>RSI</b>	
TXT 280 Pro Racing	14-19	<b>RSI</b>	
TXT 280 Pro Replica	13-13	<b>RSI</b>	
TXT 280 Racing	19-22	<b>RSI</b>	
TXT 300	04-06	<b>RSI</b>	
TXT 300 (Formula cal.)	12-12	<b>RSI</b>	
TXT 300 GP	19-22	<b>RSI</b>	
TXT 300 Pro	07-11	<b>RSI</b>	
TXT 300 Pro Racing	14-19	<b>RSI</b>	
TXT 300 Pro Replica	13-13	<b>RSI</b>	
TXT 300 Racing	19-22	<b>RSI</b>	

**HONDA**

250 Cota 4RT	04-16	<b>RSI</b>	
Cota 260 4Ride	16-19	<b>RSI</b>	



<b>HONDA</b>			
Cota 260 4RT	04-16	<b>RSI</b>	
Cota 260 4RT Race			
Replica	15-19	<b>RSI</b>	
Cota 300 RR	16-19	<b>RSI</b>	

**HUSQVARNA**

CR 50 Junior	06-06	<b>RSI</b>	
CR 50 Pro Senior	06-06	<b>RSI</b>	
CR 50 Senior	06-06	<b>RSI</b>	

**JOTAGAS**

JT 125	14-19	<b>RSI</b>	
JT 250	14-19	<b>RSI</b>	
JT 280	14-19	<b>RSI</b>	
JT 300	14-19	<b>RSI</b>	

**MONTESA**

250 Cota 4RT	04-16	<b>RSI</b>	
Cota 260 4Ride	16-19	<b>RSI</b>	
Cota 260 4RT	04-16	<b>RSI</b>	
Cota 260 4RT Race			
Replica	15-19	<b>RSI</b>	
Cota 300 RR	16-19	<b>RSI</b>	
360 315R	01-04	<b>RSI</b>	

**OSSA**

TR 125 i	15-15	<b>RSI</b>	
TR 250 i	15-15	<b>RSI</b>	
TR 280 i	10-15	<b>RSI</b>	
TR 280 i Explorer	12-15	<b>RSI</b>	
TR 300 Factory R	15-15	<b>RSI</b>	
TR 300 i	15-15	<b>RSI</b>	

**SCORPA**

SY 115 F Trial	06-06	<b>RSI</b>	
TY-S 115 F Trial	06-06	<b>RSI</b>	
125 Twenty Trial	16-18	<b>RSI</b>	



<b>SCORPA</b>			
SY 125 F Trial	06-11	<b>RSI</b>	
TY-S 125 F Trial	06-08	<b>RSI</b>	
250 Twenty Trial	16-18	<b>RSI</b>	
SY 250 F Trial	06-11	<b>RSI</b>	
SY 250 Trial	00-01	<b>RSI</b>	
300 Twenty Trial	16-18	<b>RSI</b>	

**SHERCO**

ST 80 (Formula cal.)	13-14	<b>RSI</b>	
ST 125 (Formula cal.)	13-14	<b>RSI</b>	
ST 125 1,25	06-11	<b>RSI</b>	
ST 250 (Formula cal.)	13-14	<b>RSI</b>	
ST 250 2,5	01-01	<b>RSI</b>	
ST 290 (Formula cal.)	13-14	<b>RSI</b>	
ST 290 2,9	01-01	<b>RSI</b>	
ST 300	16-19	<b>RSI</b>	
ST 305 (Formula cal.)	13-14	<b>RSI</b>	
ST 320 3.2F	05-05	<b>RSI</b>	

**TRS**

125 ONE	19-20	<b>RSI</b>	
125 RR ONE	19-20	<b>RSI</b>	
250 ONE	16-19	<b>RSI</b>	
250 RR ONE	19-20	<b>RSI</b>	
280 ONE	16-19	<b>RSI</b>	
280 RR ONE	19-20	<b>RSI</b>	
300 ONE	16-19	<b>RSI</b>	
300 RR ONE	19-20	<b>RSI</b>	

**VERTIGO**

300 Combat Camo			
Works	15-19	<b>RSI</b>	
300 Combat Ice			
Hell	15-19	<b>RSI</b>	
300 Combat RR	15-19	<b>RSI</b>	



Available compounds

HF • RSI

SBS 802

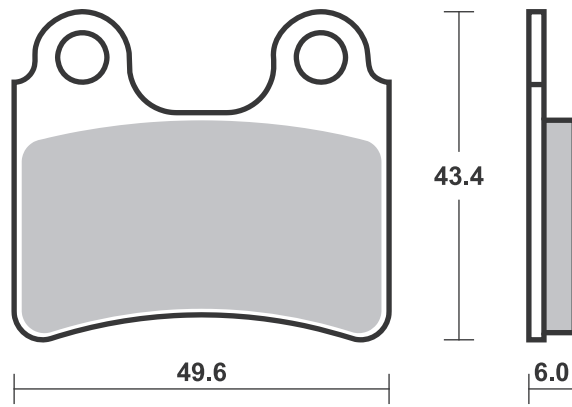

Available compounds

HF • RSI

SBS 803

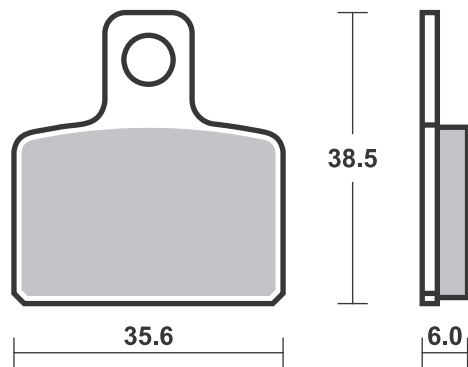



Available compounds

DC • DS-1 • DS-2

SBS 805

1 set = 4 pcs.

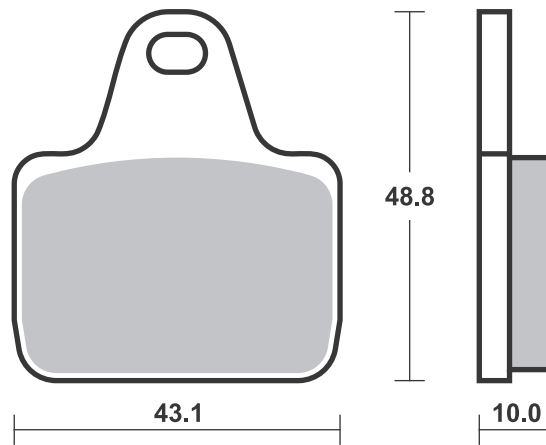

Available compounds

HS • SP • DC • RST • DS-1 • DS-2

SBS 806

HS / SP - Th. 8.0  
RST / DC / DS - Th. 9.0

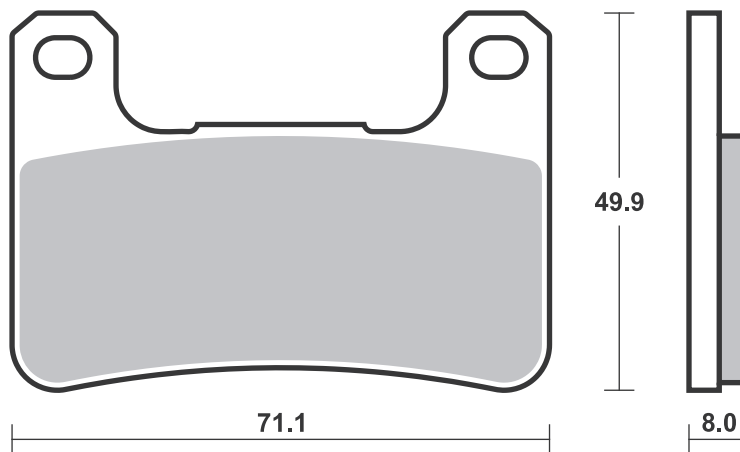



Available compounds

**H.HF • H.CT • H.HS**

**SBS 807**

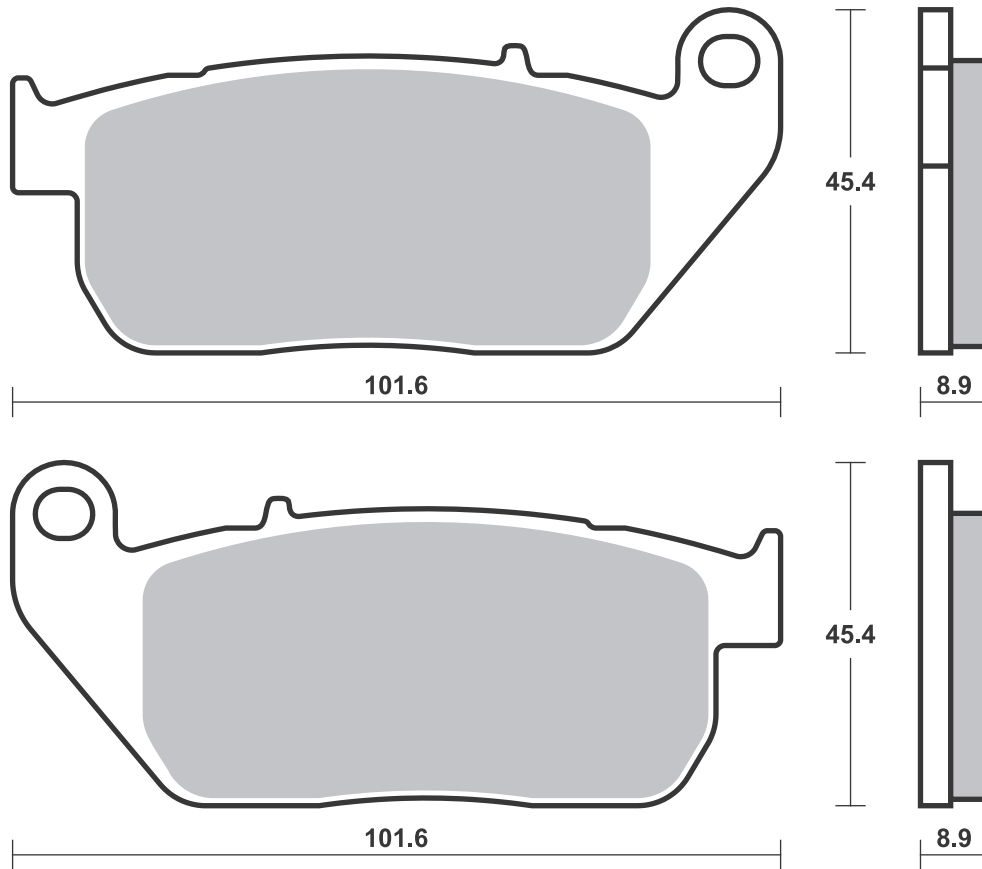

Available compounds

**H.HF • H.CT • H.LS**

**SBS 808**

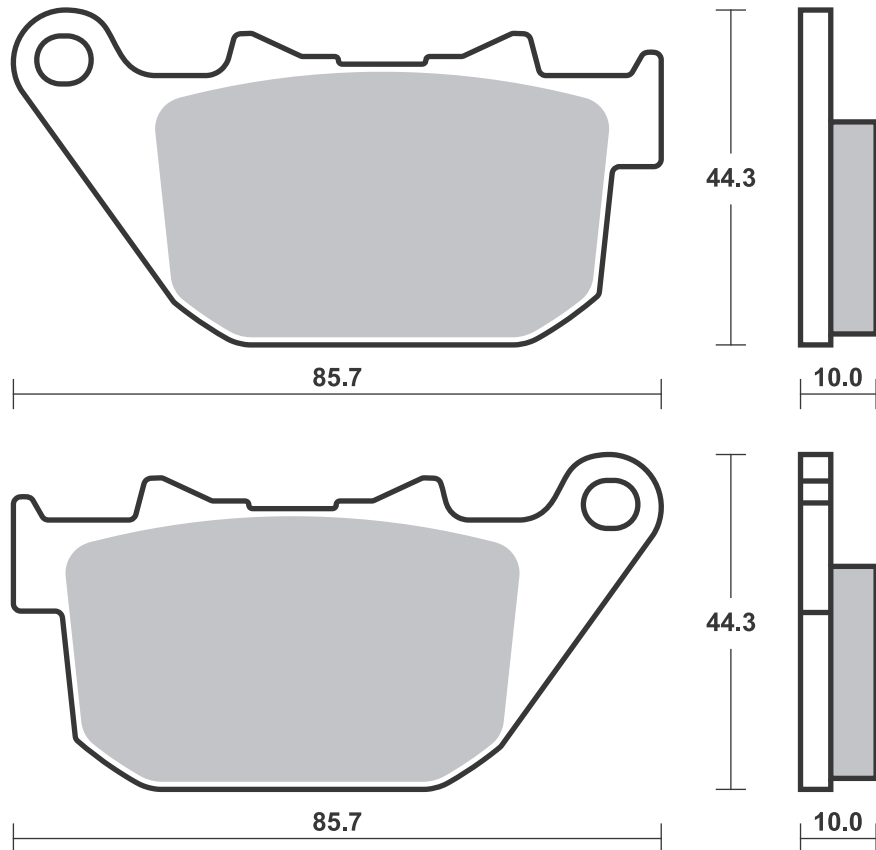



Available compounds

HS • SP • DC • RST • DS-1 • DS-2

SBS 809

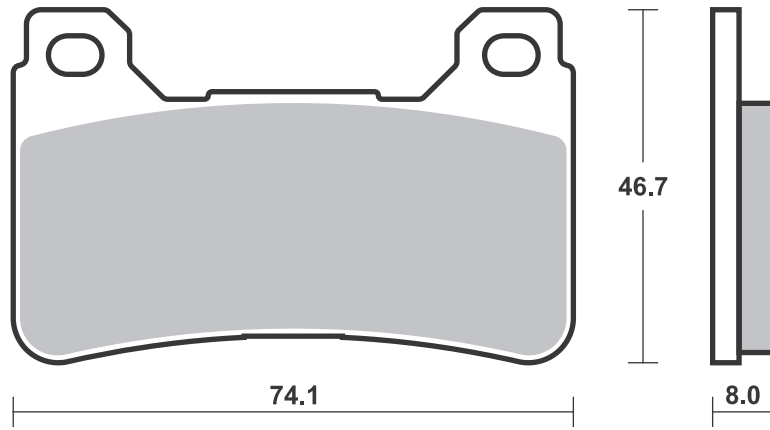

HS / SP - Th. 8.0  
RST / DC / DS - Th. 9.0

Available compounds

HF • RQ • CS • SI • RSI

SBS 810

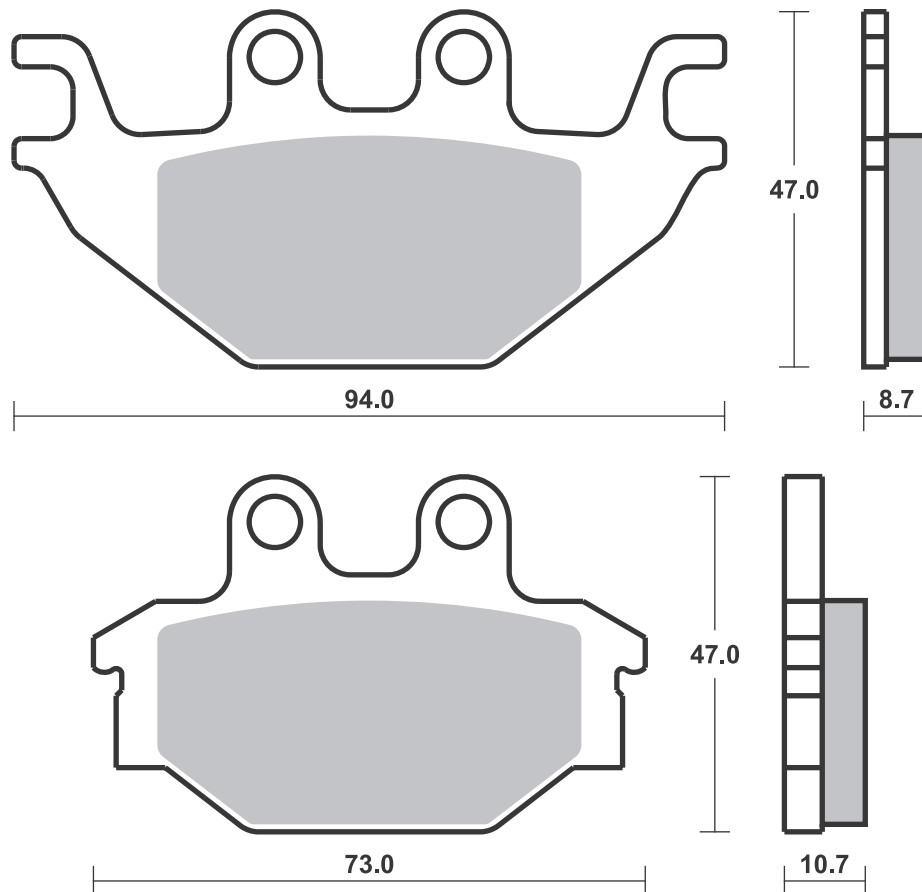





Available compounds

SI • RSI

SBS 813

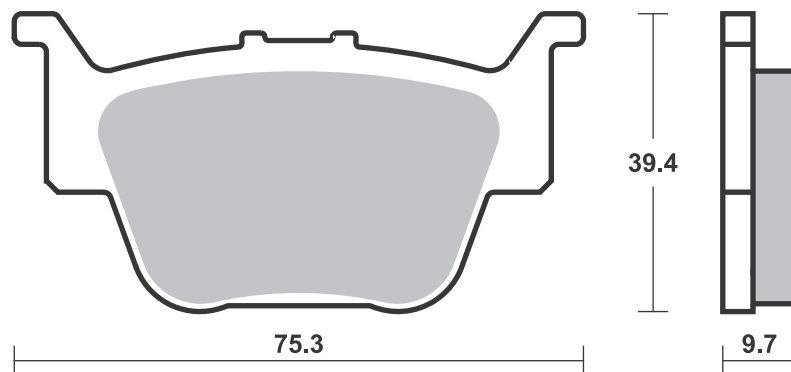

Available compounds

HF • HS • LS

SBS 814

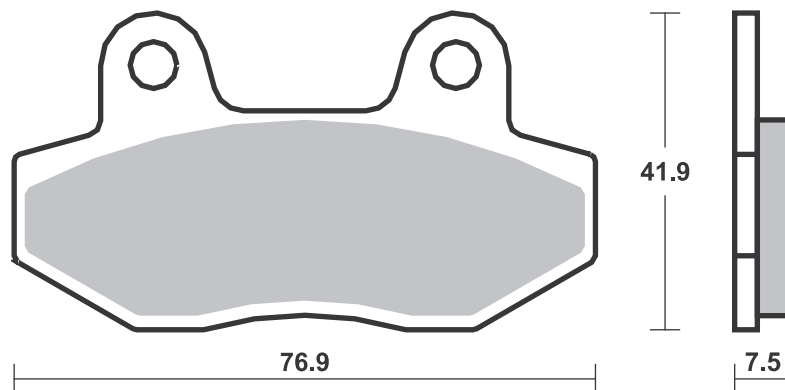

Available compounds

HF

SBS 815

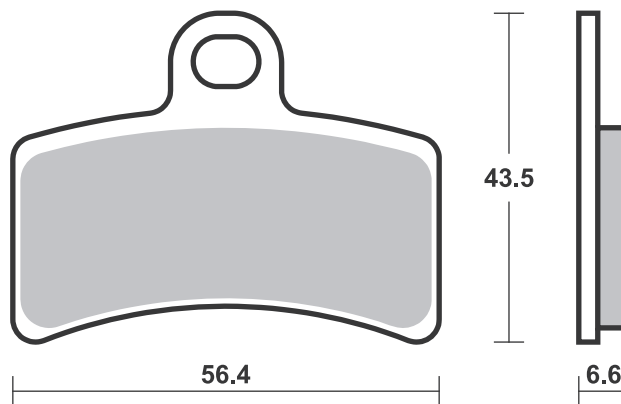

Brake Pad 1:1 Drawings,  
Compounds, Fitments

# Applications

## SBS 816 Recommended compound



### YAMAHA

YXR	450 Rhino	06-09	SI
	660 Rhino	05-08	SI
YFM	700 R Raptor	06-08	SI
YFM	700 Raptor	09-12	SI

## SBS 817 Recommended compound



### TOMOS

MC	125 T	06-08	HF
SE	125	05-08	HF

Brake Pad 1:1 Drawings,  
Compounds, Fitments

Available compounds

SI • RSI

SBS 816

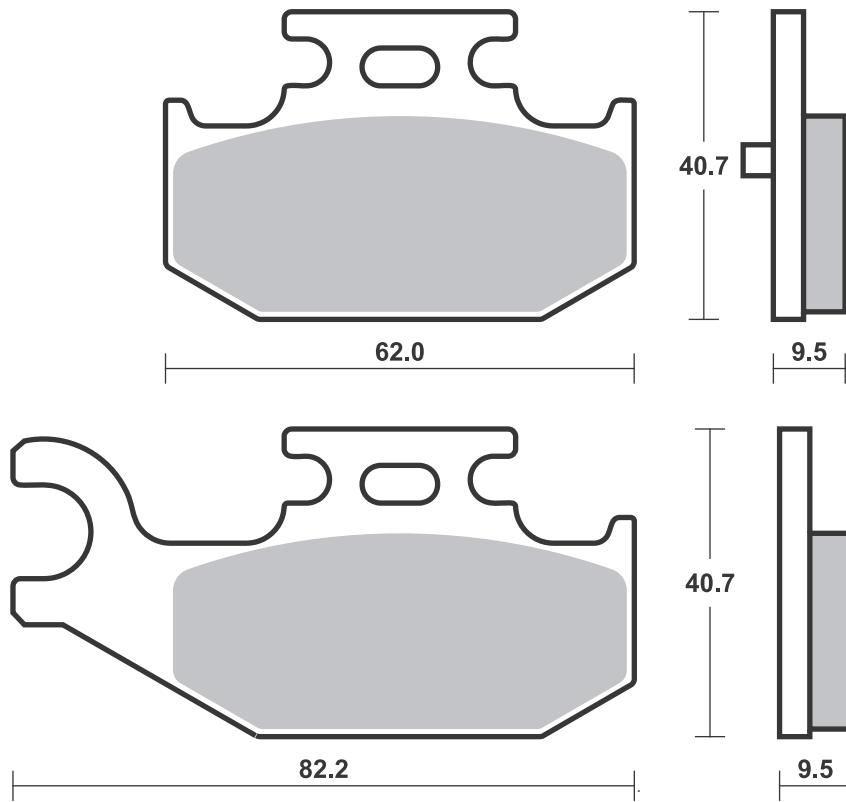

Available compounds

HF

SBS 817

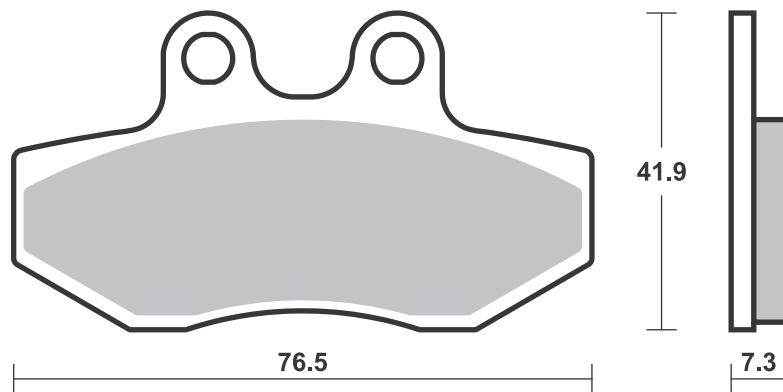



Available compounds

CS • SI • RSI

SBS 820

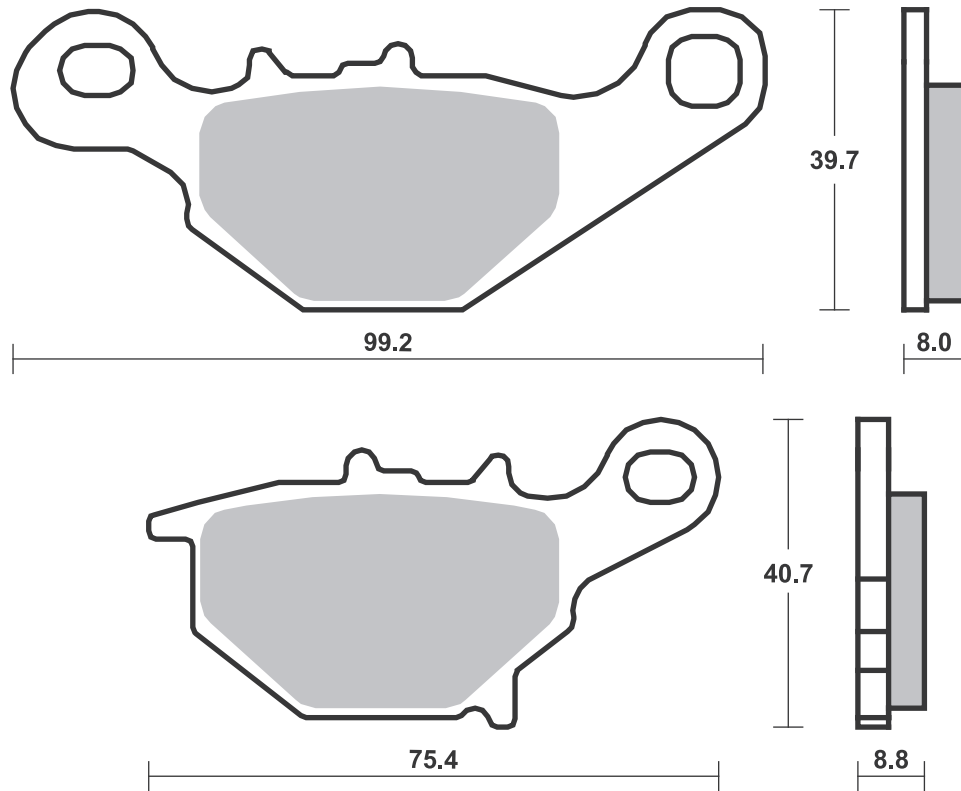

Available compounds

HF • HS

SBS 821

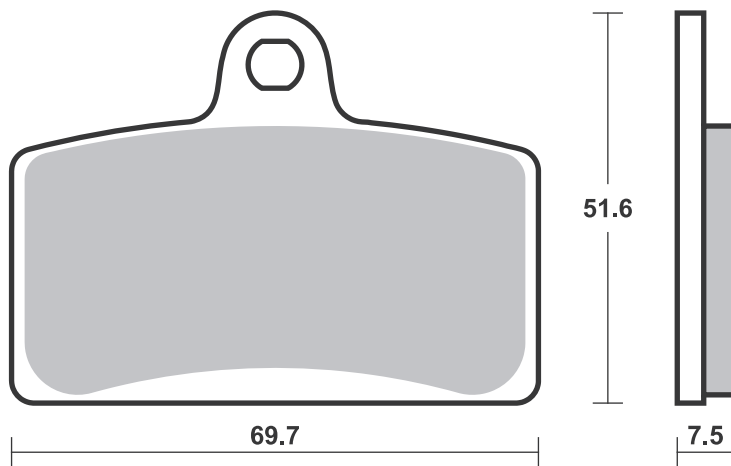



Available compounds

SI • RSI • ATS • PSI

SBS 822

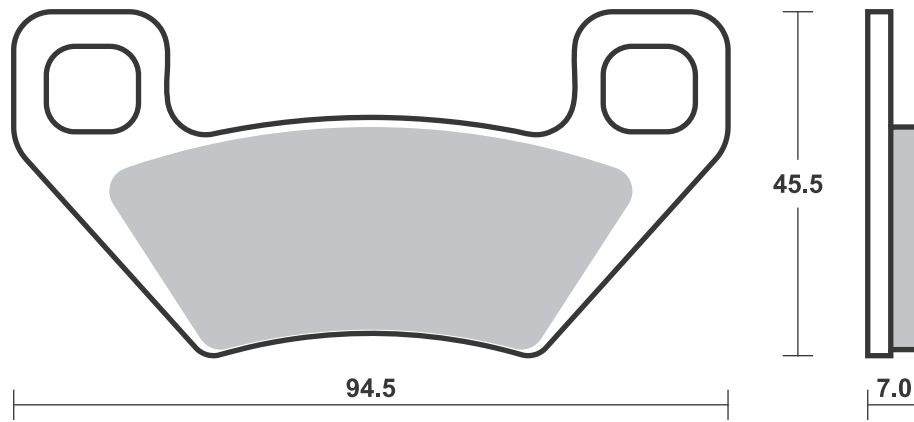

Available compounds

DC • DS-1 • DS-2

SBS 825

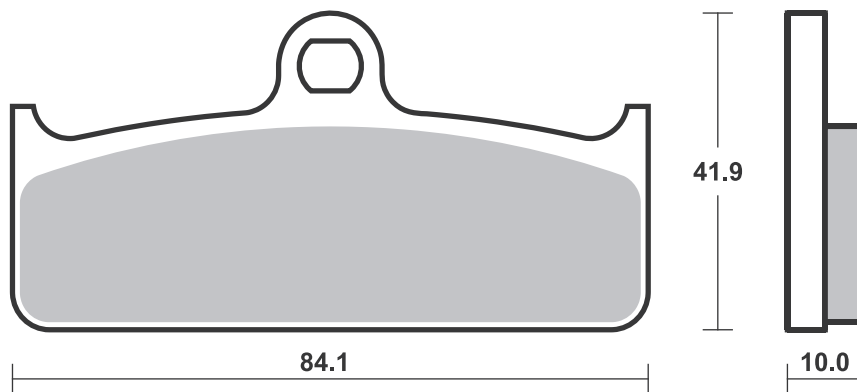



HARLEY DAVIDSON				
XL	883 R Sportster	00-03	H.HS	H.LS
XL	883 Sportster			
	Custom	00-03	H.HS	H.LS
XLH	883 Sportster	00-03	H.HS	H.LS
XLH	883 Sportster			
	Hugger	00-03	H.HS	H.LS
VRSCA	1130 V-Rod	02-05	H.HS	H.LS
VRSCB	1130 V-Rod	04-04	H.HS	H.LS
XL	1200 Sportster			
	Custom	00-03	H.HS	H.LS
XL	1200 Sportster			
	Sport	00-03	H.HS	H.LS
XLH	1200 Sportster	00-03	H.HS	H.LS
FLHR/I	1450 Road King	00-06	H.HS	H.LS
FLHRCI	1450 Road King			
	Classic	00-06	H.HS	H.LS
FLHRS/I	1450 Road King			
	Custom	04-06	H.HS	H.LS
FLHT/I	1450 Electra Glide			
	Standard	00-06	H.HS	H.LS
FLHTC/I	1450 Electra Glide			
	Classic	00-06	H.HS	H.LS
FLHTCUI	1450 Ultra Classic			
	Electra			
	Glide	00-06	H.HS	H.LS
FLHXI	1450 Street Glide	06-06	H.HS	H.LS
FLSTC	1450 Softail	06-07	H.HS	H.LS
FLSTC/I	1450 Heritage			
	Softail			
	Classic	00-04	H.HS	H.LS
FLSTCI	1450 Softail	06-06	H.HS	H.LS
FLSTF	1450 Fat Boy	06-07	H.HS	H.LS
FLSTF/I	1450 Fat Boy	00-04	H.HS	H.LS
FLSTFI	1450 Fat Boy	06-06	H.HS	H.LS
FLSTI	1450 Heritage			
	Softail	06-06	H.HS	
FLSTNI	1450 Softail			
	Deluxe	06-06	H.HS	H.LS
FLSTS/I	1450 Heritage			
	Springer	00-03		H.LS
FLSTSC/I	1450 Springer			
	Softail			
	Classic	06-06		H.LS
FLTR/I	1450 Road Glide			
	Classic	00-06	H.HS	H.LS
FXD	1450 Dyna Super			
	Glide	00-03	H.HS	H.LS
FXDBI	1450 Dyna Street			
	Bob	06-06	H.HS	H.LS
FXDC/I	1450 Dyna Super			
	Glide			
	Custom	05-06	H.HS	H.LS
FXDI	1450 35th			
	Anniversary			
	Super Glide	06-06	H.HS	
FXDI	1450 Dyna Super			
	Glide	04-07	H.HS	H.LS
FXDL	1450 Dyna Low			
	Rider	00-03	H.HS	H.LS
FXDLI	1450 Dyna Low			
	Rider	04-06	H.HS	H.LS
FXDS	1450 Dyna			
	Convertible	00-02	H.HS	H.LS
FXDWG	1450 Dyna Wide			
	Glide	00-03	H.HS	H.LS
FXDWGI	1450 Dyna Wide			
	Glide	04-06	H.HS	H.LS



HARLEY DAVIDSON				
FXDX	1450 Dyna Super			
	Glide Sport	00-03	H.HS	H.LS
FXDXI	1450 Dyna Super			
	Glide Sport	04-06	H.HS	H.LS
FXDXT	1450 Dyna Super			
	Glide T-Sport	00-03	H.HS	H.LS
FXST/I	1450 Softail			
	Standard	00-06	H.HS	H.LS
FXST/I	1450 Softail			
	Standard	06-06	H.HS	
FXSTB/I	1450 Night Train	00-06	H.HS	H.LS
FXSTB/I	1450 Night Train	06-06	H.HS	
FXSTD/I	1450 Softail Deuce	00-06	H.HS	H.LS
FXSTD/I	1450 Softail Deuce	06-06	H.HS	
FXSTS/I	1450 Softail	05-05		H.LS
FXSTS/I	1450 Springer			
	Softail	00-04		H.LS
FLHR	1584 Road King	07-07	H.HS	H.LS
FLHRC	1584 Road King			
	Classic	07-07	H.HS	H.LS
FLHRS	1584 Road King			
	Custom	07-07	H.HS	H.LS
FLHT	1584 Electra Glide			
	Standard	07-07	H.HS	H.LS
FLHTC	1584 Electra Glide			
	Classic	07-07	H.HS	H.LS
FLHTCU	1584 Ultra Classic			
	Electra Glide	07-08	H.HS	H.LS
FLHX	1584 Street Glide	07-07	H.HS	H.LS
FLSTC	1584 Heritage			
	Softail			
	Classic	07-07	H.HS	
FLSTF	1584 Fat Boy	07-07	H.HS	
FLSTN	1584 Softail			
	Deluxe	07-07	H.HS	
FXD	1584 Dyna Super			
	Glide	07-07	H.HS	H.LS
FXDB	1584 Dyna Street			
	Bob	07-07	H.HS	H.LS
FXDC	1584 Dyna Super			
	Glide			
	Custom	07-07	H.HS	H.LS
FXDL	1584 Dyna Low			
	Rider	07-07	H.HS	H.LS
FXDWG	1584 Dyna Wide			
	Glide	07-07	H.HS	H.LS
FXST	1584 Softail			
	Standard	07-07	H.HS	
FXSTB	1584 Night Train	07-07	H.HS	
FXSTC	1584 Softail			
	Custom	07-07	H.HS	
FXSTD	1584 Softail Deuce	07-07	H.HS	



Available compounds

**H.HF • H.CT • H.HS • H.LS**

**SBS 826**

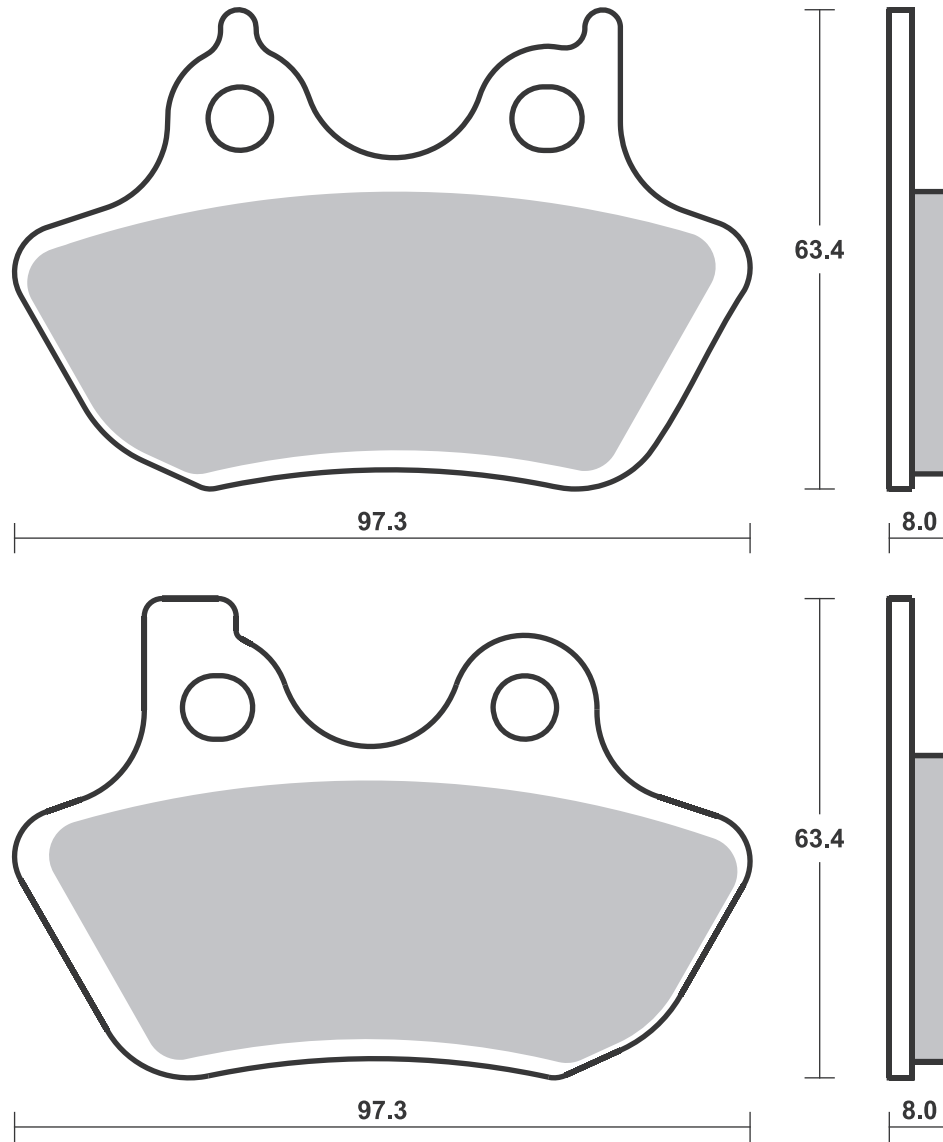

# Applications

## SBS 827 Recommended compound



ARCTIC CAT		
250 2x4 (Man.		
Hand Brake	99- 04	<b>ATS</b>
250 4x4 (Man.		
Hand Brake	00- 04	<b>ATS</b>
300 2x4 (Man.		
Hand Brake	98- 04	<b>ATS</b>
300 4x4 (Man.		
Hand Brake	98- 05	<b>ATS</b>
375 2x4/4x4 (Man.		
Hand Brake	02- 02	<b>ATS</b>
400 2x4 (Man.		
Hand Brake	98- 02	<b>ATS</b>
400 2x4/4x4 (FIS)		
Aut.(Man.		
Hand Brake	03- 04	<b>ATS</b>
400 2x4/4x4 (FIS)		
(Man.		
Hand Brake	02- 04	<b>ATS</b>
400 4x4 (Man.		
Hand Brake	98- 04	<b>ATS</b>
400 TBX 4x4 (Man.		
Hand Brake	04- 04	<b>ATS</b>
454 Bear Cat		
2x4/4x4 (Man.		
Hand Brake	98- 98	<b>ATS</b>
500 2x4 (FIS)		
(Man.		
Hand Brake	02- 02	<b>ATS</b>



ARCTIC CAT		
500 2x4 (Man.		
Hand Brake	02- 02	<b>ATS</b>
500 4x4 (FIS) Aut.		
(Man.		
Hand Brake	02- 03	<b>ATS</b>
500 4x4 (FIS)		
(Man.		
Hand Brake	02- 03	<b>ATS</b>
500 4x4 (Man.		
Hand Brake	98- 02	<b>ATS</b>
500 TBX 4x4		
(Man.		
Hand Brake	03- 04	<b>ATS</b>
500 TBX 4x4 Aut.		
(Man.		
Hand Brake	02- 02	<b>ATS</b>
500 TRV 4x4		
(Man.		
Hand Brake	03- 04	<b>ATS</b>

## SBS 828 Recommended compound



HONDA		
CBR 250 R ABS		
(Nissin cal)	11- 13	<b>HS</b>
CB 600 Hornet ABS	07- 12	<b>HS</b>
CBR 600 F ABS	11- 13	<b>HS</b>
DN-01 680	08- 11	<b>HS</b>
NC 700 D Integra	12- 13	<b>HS</b>
NC 700 SA ABS	12- 13	<b>HS</b>
NC 700 SD ABS	12- 13	<b>HS</b>
NC 700 XA ABS	12- 13	<b>HS</b>
NC 700 XD ABS	12- 13	<b>HS</b>
NT 700 Deauville ABS	06- 12	<b>HS</b>
NT 700 V Varadero,		
ABS	10- 13	<b>HS</b>
VT 750 C2S ABS	13- 14	<b>HS</b>
VT 750 CS ABS	13- 14	<b>HS</b>
VFR 800 Crossrunner	11- 13	<b>HS</b>
VFR 800 Interceptor	06- 18	<b>HS</b>
VFR 800 Interceptor		
ABS	06- 18	<b>HS</b>
CB 1000 R ABS	08- 16	<b>HS</b>
CB 1100	13- 13	<b>HS</b>
VFR 1200 XC		
Crosstourer	12- 19	<b>SP</b>
VFR 1200 XDC		
Crosstourer		
w/DCT	12- 19	<b>SP</b>
CB 1300 S	11- 15	<b>HS</b>
CTX 1300	14- 18	<b>HS</b>
ST 1300 , ABS	08- 13	<b>HS</b>
VT 1300 CXA A Fury		
ABS	10- 18	<b>HS</b>



SUZUKI		
C109R 1800	08- 12	<b>HS</b>

Available compounds

ATS

SBS 827

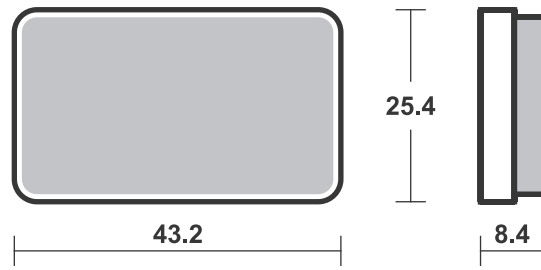

Available compounds

HF • HS • LS • SP

SBS 828

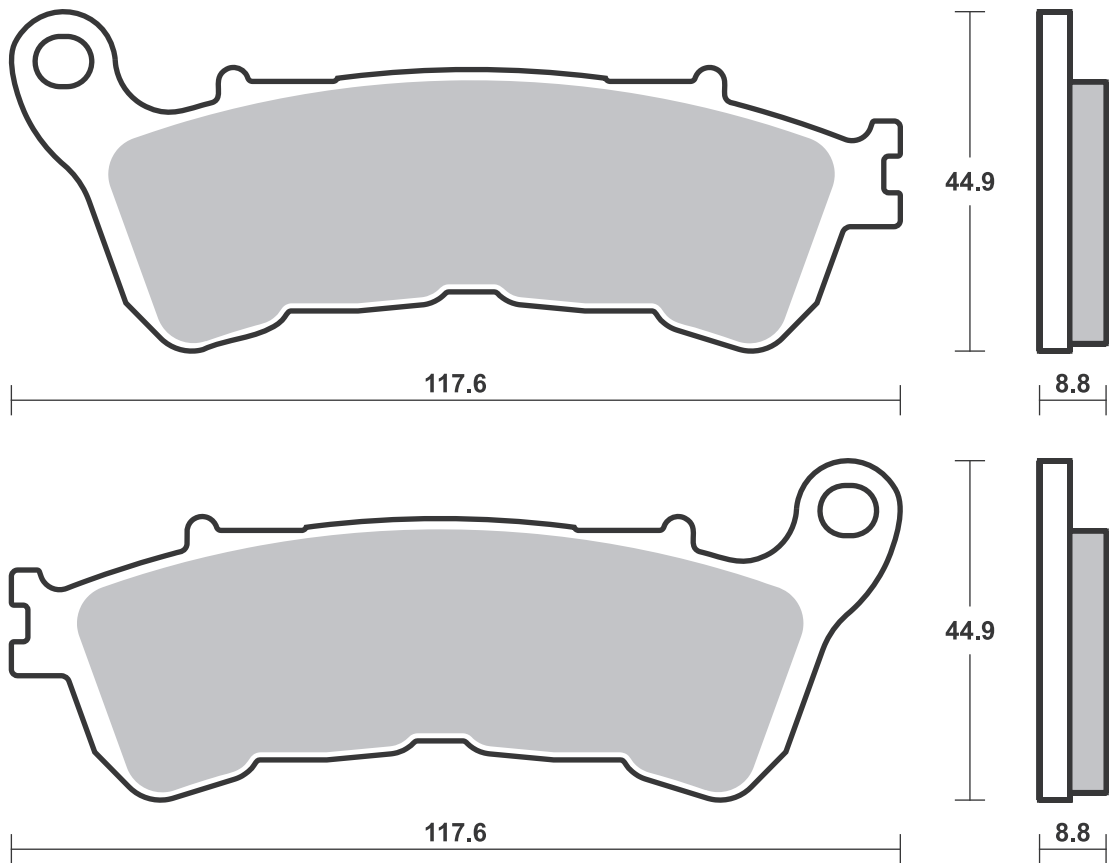



Available compounds

SI

SBS 829

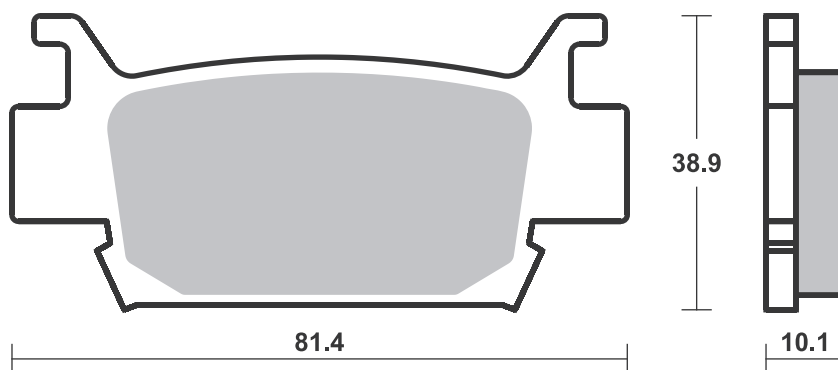

Available compounds

H.HF • H.CT • H.HS • H.LS

SBS 830

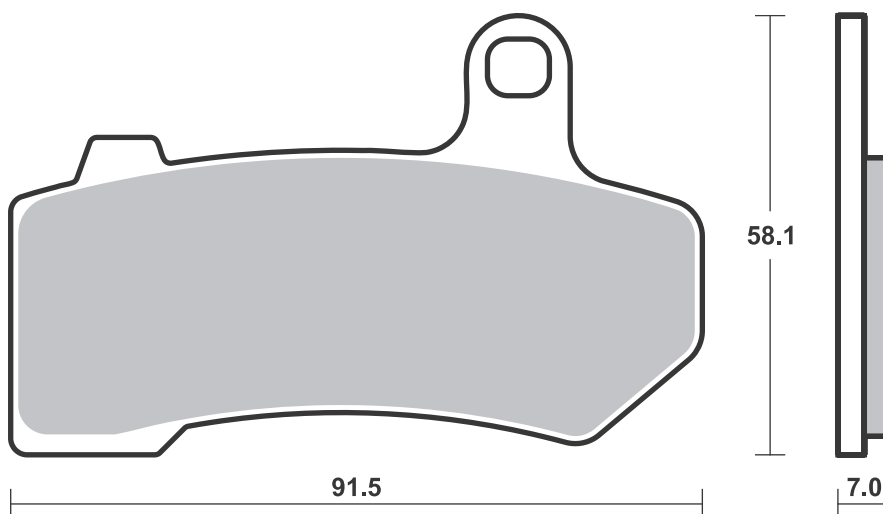
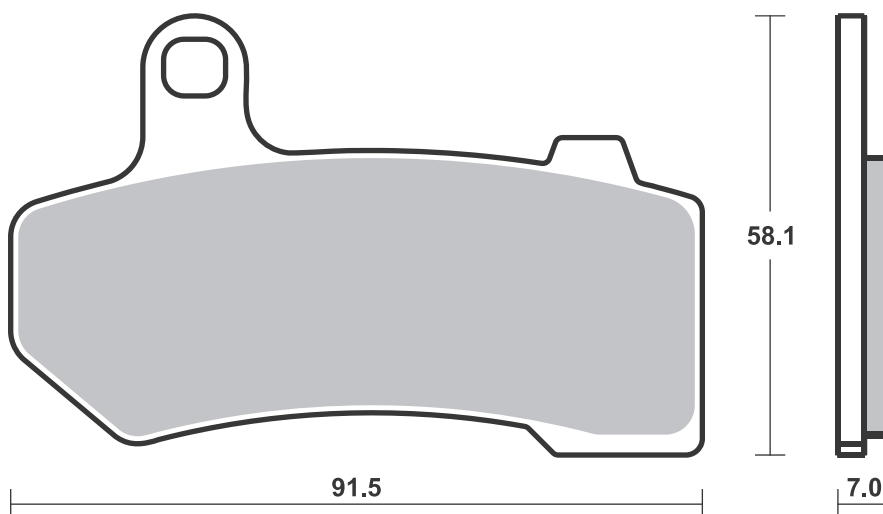



Available compounds

HF • LS

SBS 832

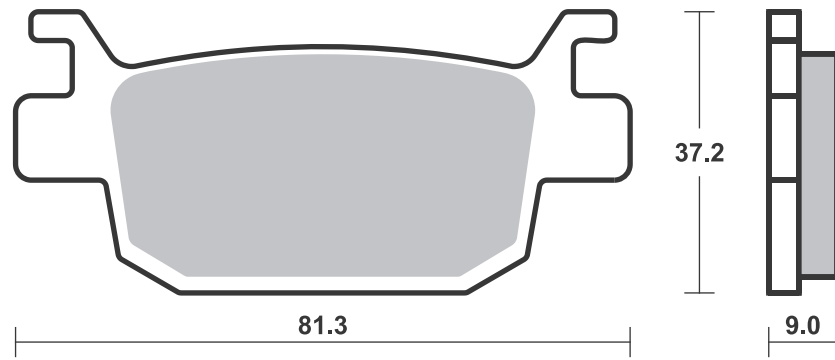

Available compounds

HF • LS • RQ

SBS 833

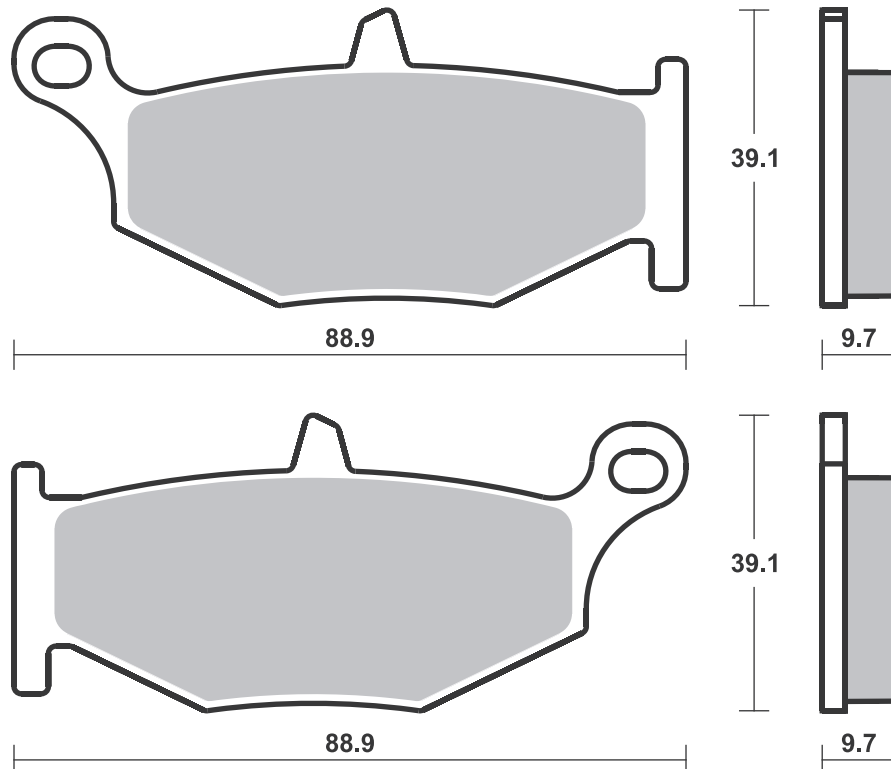

# Applications

## SBS 834 Recommended compound



<b>HONDA</b>			
CBR	600 F	11-13	<b>LS</b>
CBR	600 RR	07-21	<b>LS</b>
CBR	1000 RR Fireblade	06-16	<b>LS</b>
CBR	1000 RR SP	14-22	<b>LS</b>
CBR	1000 RR SP2	17-19	<b>LS</b>

<b>KAWASAKI</b>			
ZX-6R	636 Ninja	13-18	<b>LS</b>
ZX-6R	636 Ninja KRT		
	ABS	13-18	<b>LS</b>
ZX-6R	636 Ninja		
	Upgrade DS	13-22	<b>LS</b>
ZX-10R	1000 Ninja	11-22	<b>LS</b>
ZX-10R	1000 Ninja ABS	12-15	<b>LS</b>
ZX-10R	1000 Ninja KRT	16-18	<b>LS</b>
ZX-10R	1000 Ninja SE	18-22	<b>LS</b>
ZX-10RR	1000 Ninja	17-22	<b>LS</b>

<b>SUZUKI</b>			
GSX-R	600	11-21	<b>LS</b>
GSX-R	750	11-18	<b>LS</b>
GSX-R	1000	09-22	<b>LS</b>
GSX-R	1000 R	17-22	<b>LS</b>

<b>YAMAHA</b>			
YZF	600 R6	17-22	<b>LS</b>
YZF	600 R6 Quick		
	change /		
	Front wheel	17-22	<b>LS</b>
YZF	1000 R1	15-22	<b>LS</b>



<b>YAMAHA</b>			
YZF	1000 R1M	15-22	<b>LS</b>
YZF	1000 R1S	16-16	<b>LS</b>

## SBS 835 Recommended compound



<b>SUZUKI</b>			
KLT-A	400 King Quad	08-14	<b>SI</b>
KLT-F	400 King Quad	08-14	<b>SI</b>
LT-A	400 King Quad	08-14	<b>SI</b>
LT-F	400 King Quad	08-14	<b>SI</b>
LT-A	450 King Quad	08-14	<b>SI</b>
LT-A	500 King Quad	11-14	<b>SI</b>
LT-A	700 King Quad	05-11	<b>SI</b>
LT-A	750 King Quad	08-14	<b>SI</b>



Available compounds

**HF • LS • RQ**

**SBS 834**

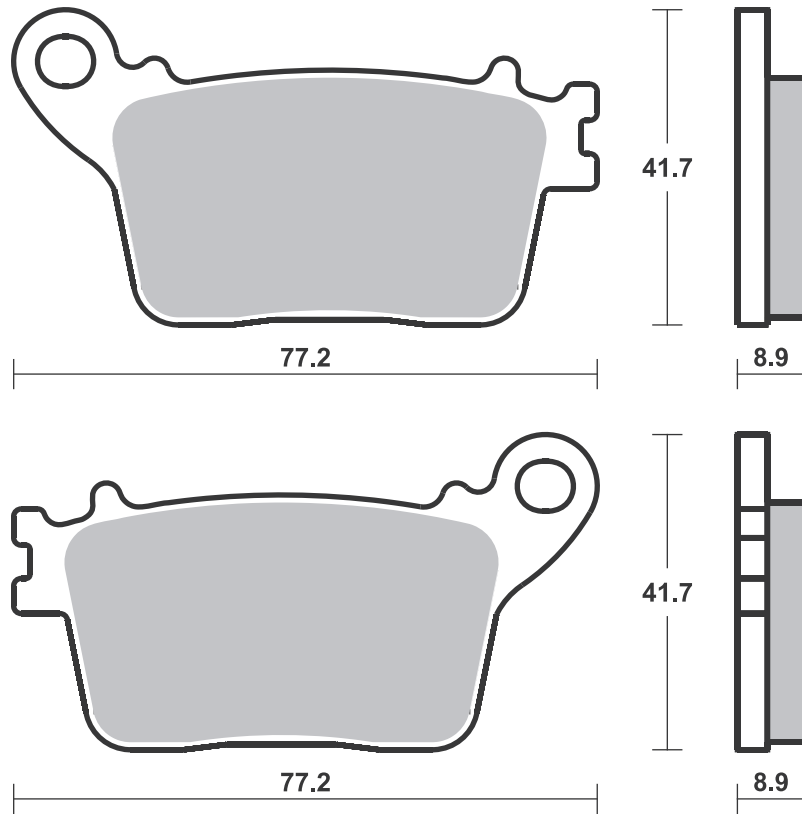

Available compounds

**SI • RSI**

**SBS 835**

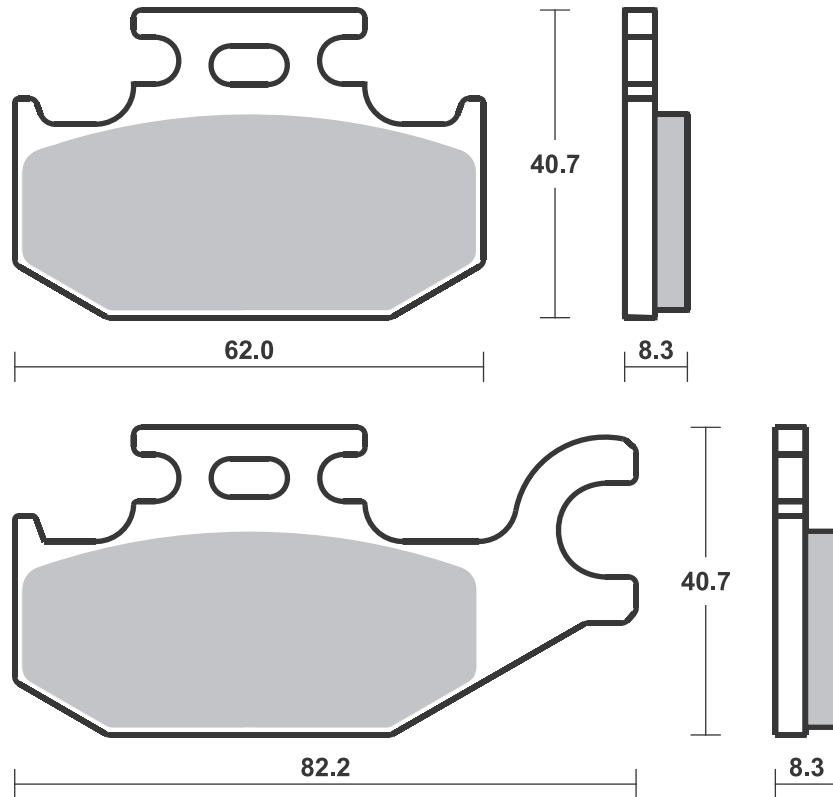



Available compounds

SI • RSI

SBS 836

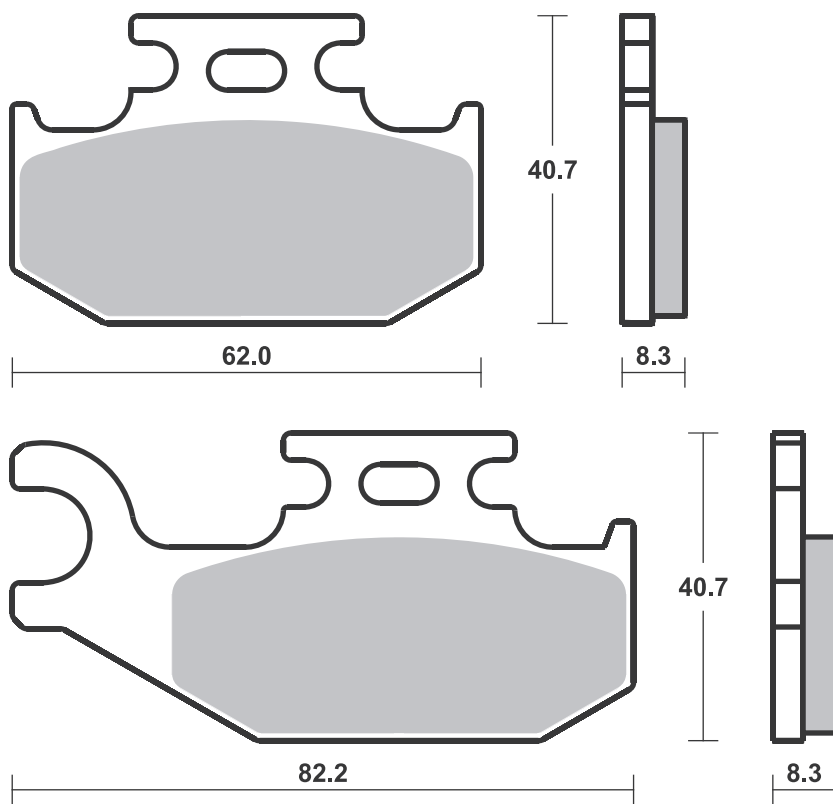

Available compounds

HS • SP • DC • RST • DS-1 • DS-2

SBS 838

1 set = 4 pcs.

HS / SP - Th. 7.8

RST / DC / DS - Th. 9.0

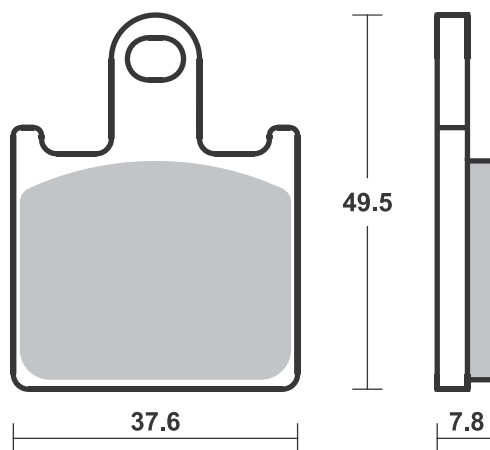



Available compounds

HS • SP • DC • RST • DS-1

SBS 839

1 set = 2 pcs. small / large

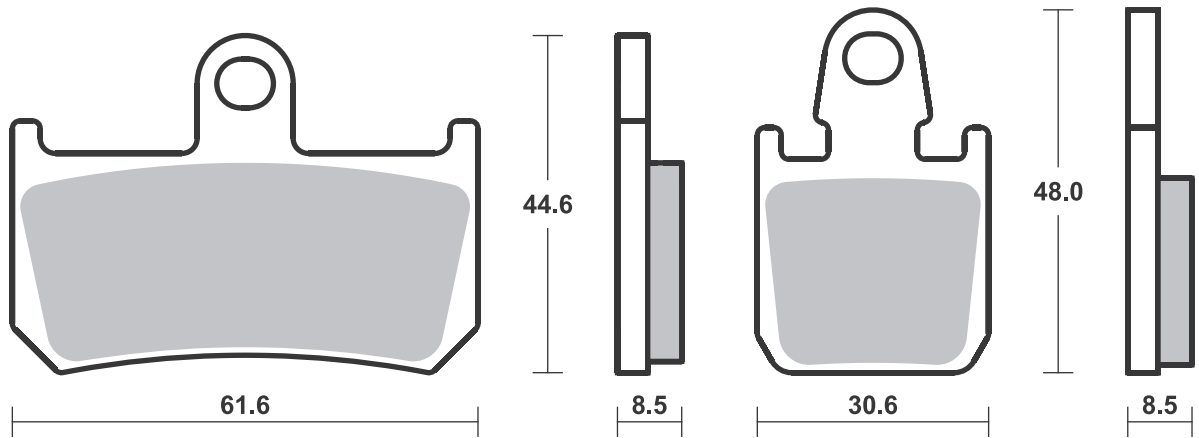

Available compounds

CS • SI • RSI

SBS 840

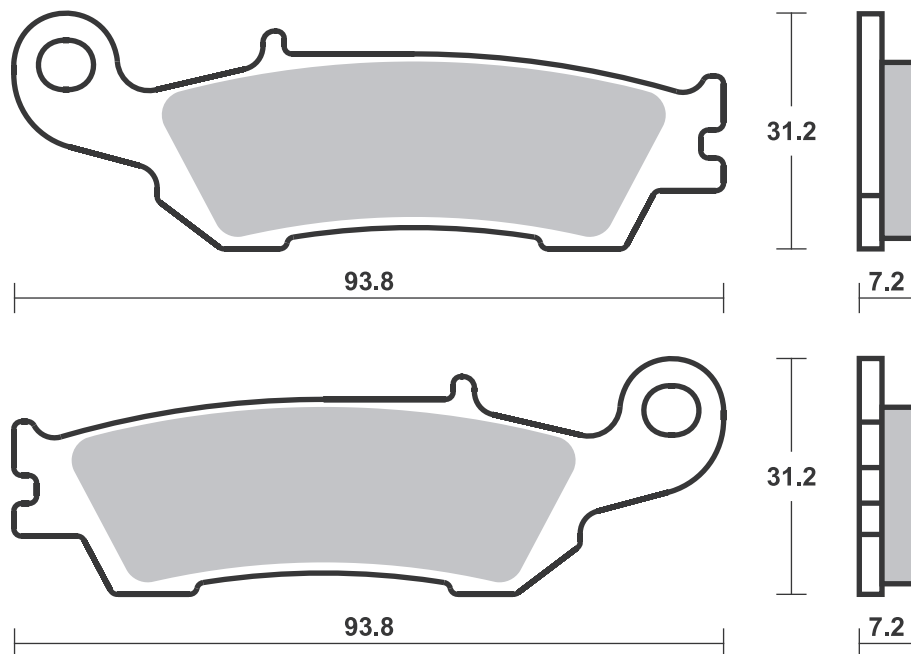



<b>APRILIA</b>			
RSV4	1000 , ABS	09- 13	<b>SP</b>
RSV4-R1000 , ABS APRC		10- 10	<b>SP</b>
RSV4	1100 Factory	19- 20	<b>SP</b>
<b>BENELLI</b>			
TnT	1130 R	17- 17	<b>HS</b>
<b>BIMOTA</b>			
3D	800 Tesi	16- 16	<b>HS</b>
	1200 Impeto	16- 17	<b>HS</b>
<b>BREMO RACING CALIPERS</b>			
100 mm Radial Caliper			
.484, 220B47310, P4 32			
100 mm Radial GP4			
RX 220B01020 P4 32			
(disc min. Th. 4.5 mm)			
100 mm Radial Monoblock			
220988530, P4 34			
108 mm Radial Caliper			
.484, 220B47310, P4 32			
108 mm Radial GP4 RX			
220B01020 P4 32			
(disc min. Th. 4.5 mm)			
108 mm Radial Monoblock			
220A39710, P4 34			
130 mm Radial GP4			
RX 220B01020 P4 32			
(disc min. Th. 4.5 mm)			
Radial GP4 RX 220B01010			
<b>CF MOTO</b>			
	700 CL-X Sport	22- 22	<b>SP</b>
<b>DUCATI</b>			
	848 EVO	11- 12	<b>HS</b>
	848 Streetfighter S	12- 15	<b>HS</b>
D16RR	990 Desmosedici		
	RR	07- 08	<b>HS</b>
	998 Panigale V4 R	19- 21	<b>SP</b>
	998 Superleggera		
	V4	20- 21	<b>SP</b>
	1098	07- 08	<b>HS</b>
	1098 R	08- 10	<b>SP</b>
	1098 R Bayliss LE	09- 10	<b>SP</b>
	1098 S	07- 08	<b>HS</b>
	1098 Streetfighter	09- 14	<b>HS</b>
	1098 Streetfighter S	09- 13	<b>HS</b>
	1100 Hypermotard		
	EVO SP	10- 12	<b>HS</b>
	1100 Hypermotard		
	S	07- 09	<b>HS</b>
	1100 Panigale V4	18- 21	<b>SP</b>
	1100 Panigale V4 S	18- 21	<b>SP</b>
	1100 Panigale V4 S		
	Corse	19- 19	<b>SP</b>
	1100 Panigale V4		
	SP	21- 21	<b>SP</b>
	1100 Panigale V4		
	Speciale	18- 19	<b>SP</b>
	1103 Streetfighter		
	V4	20- 22	<b>SP</b>
	1103 Streetfighter		
	V4 S	20- 22	<b>SP</b>
	1103 Streetfighter		
	V4 SP	22- 22	<b>SP</b>



<b>DUCATI</b>			
	1158 Multistrada		
	V4		
	Pikes Peak	22- 22	<b>SP</b>
	1158 Multistrada		
	V4S	21- 22	<b>SP</b>
	1158 Multistrada		
	V4S Sport	21- 22	<b>SP</b>
	1198	09- 13	<b>SP</b>
	1198 S	09- 12	<b>SP</b>
	1198 SP	11- 12	<b>SP</b>
	1199 Panigale	12- 14	<b>SP</b>
	1199 Panigale R	13- 15	<b>SP</b>
	1199 Panigale S	12- 14	<b>SP</b>
	1199 Superleggera	14- 14	<b>SP</b>
	1200 Monster 25		
	Anniversario	19- 19	<b>HS</b>
	1200 Monster R	16- 19	<b>HS</b>
	1200 Monster S	14- 21	<b>HS</b>
	1200 Multistrada S	15- 17	<b>SP</b>
	1200 Multistrada S		
	D-air	15- 17	<b>SP</b>
	1200 Multistrada S		
	Pikes Peak	16- 17	<b>SP</b>
	1260 Multistrada	18- 18	<b>SP</b>
	1260 Multistrada S	18- 19	<b>SP</b>
	1260 Multistrada S		
	D-air	18- 19	<b>SP</b>
	1260 Multistrada S		
	Grand Tour	20- 20	<b>SP</b>
	1260 Multistrada S		
	Pikes Peak	18- 19	<b>SP</b>
	1299 Panigale	15- 17	<b>SP</b>
	1299 Panigale R	15- 17	<b>SP</b>
	1299 Panigale R		
	Final Edition	17- 20	<b>SP</b>
	1299 Panigale S	15- 17	<b>SP</b>
	1299 Panigale S		
	Anniversario	17- 17	<b>SP</b>
	1299 Superleggera	17- 17	<b>SP</b>
<b>HONDA</b>			
CBR	1000 RR-R SP		
	Fireblade	22- 22	<b>SP</b>
<b>HUSQVARNA</b>			
FS	450	15- 22	<b>RST</b>
	900 Nuda R, ABS	12- 13	<b>HS</b>
<b>KAWASAKI</b>			
Z	1000 H2 SE	21- 21	<b>SP</b>
ZX	1000 H2 Carbon		
	Ninja	17- 20	<b>SP</b>
ZX	1000 H2 Ninja	15- 21	<b>SP</b>
ZX	1000 H2 SX SE+	19- 21	<b>SP</b>
ZX	1000 H2R Ninja	15- 20	<b>SP</b>
ZX-10R	1000 Ninja	16- 22	<b>SP</b>
ZX-10R	1000 Ninja KRT	16- 18	<b>SP</b>
ZX-10R	1000 Ninja SE	18- 22	<b>SP</b>
ZX-10RR	1000 Ninja	17- 22	<b>SP</b>
ZX-14R	1400 SE	16- 18	<b>HS</b>
<b>KTM</b>			
SX	450 SMR	13- 15	<b>RST</b>
SX	450 SMR	21- 22	<b>RST</b>
	690 Duke R	14- 17	<b>HS</b>
RC8	890 C	22- 22	<b>RST</b>



<b>KTM</b>			
	990 Supermoto R	10- 10	<b>HS</b>
RC8	1190	08- 11	<b>SP</b>
RC8	1190 R	09- 15	<b>SP</b>
RC8	1190 R Track	11- 15	<b>SP</b>
	1290 Super Duke R	14- 22	<b>HS</b>
	1290 Super Duke R		
	EVO	22- 22	<b>SP</b>
	1290 Superduke R		
	Black	20- 20	<b>SP</b>
<b>MOTUS</b>			
MST-R	1650	14- 17	<b>HS</b>
<b>MV AGUSTA</b>			
	800 Superverloce	19- 19	<b>SP</b>
F3	800 RR	21- 22	<b>SP</b>
	1000 Brutale RR	20- 20	<b>SP</b>
	1000 Rush	20- 20	<b>SP</b>
F4	1000 LH44	18- 20	<b>SP</b>
F4	1000 R	12- 19	<b>SP</b>
F4	1000 RC	15- 20	<b>SP</b>
F4	1000 RR	12- 20	<b>SP</b>
	1078 Brutale RR	09- 09	<b>HS</b>
F4	1078 CC	08- 11	<b>SP</b>
F4	1078 RR	08- 11	<b>SP</b>
	1090 Brutale Corse	14- 16	<b>HS</b>
	1090 Brutale RR	10- 17	<b>HS</b>
<b>NORTON</b>			
	1200 V4 RR	18- 19	<b>HS</b>
<b>SUZUKI</b>			
GSX-R	600	11- 21	<b>HS</b>
GSX-R	750	11- 18	<b>HS</b>
GSX-R	1000	12- 22	<b>SP</b>
GSX-R	1000 R	17- 22	<b>SP</b>
GSX-S	1000	15- 19	<b>HS</b>
GSX-S	1000 F	15- 19	<b>HS</b>
GSX-S	1000 Katana	19- 21	<b>HS</b>
GSX-R	1300 Hayabusa	13- 21	<b>HS</b>
<b>TRIUMPH</b>			
	2500 Rocket III GT	19- 22	<b>SP</b>
	2500 Rocket III R	19- 22	<b>SP</b>

Available compounds

HS • SP • DC • RST • DS-1 • DS-2

SBS 841

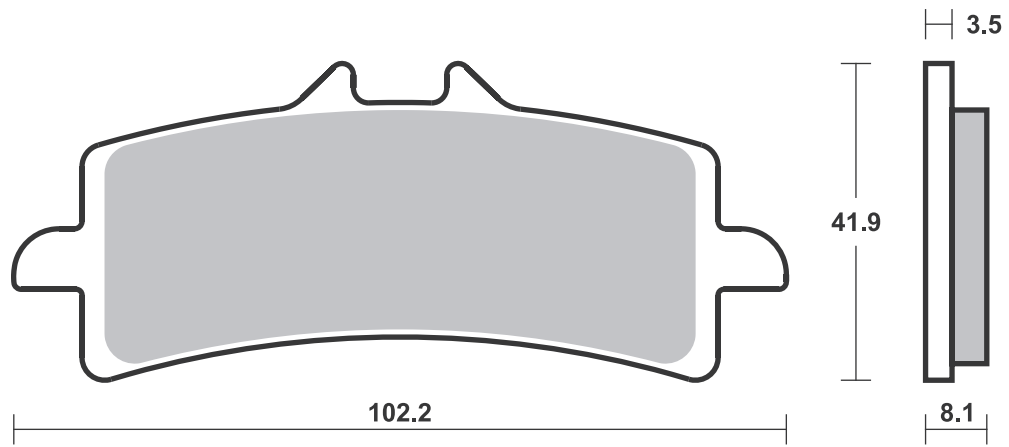





Available compounds

HS • RST • RSI

SBS 842

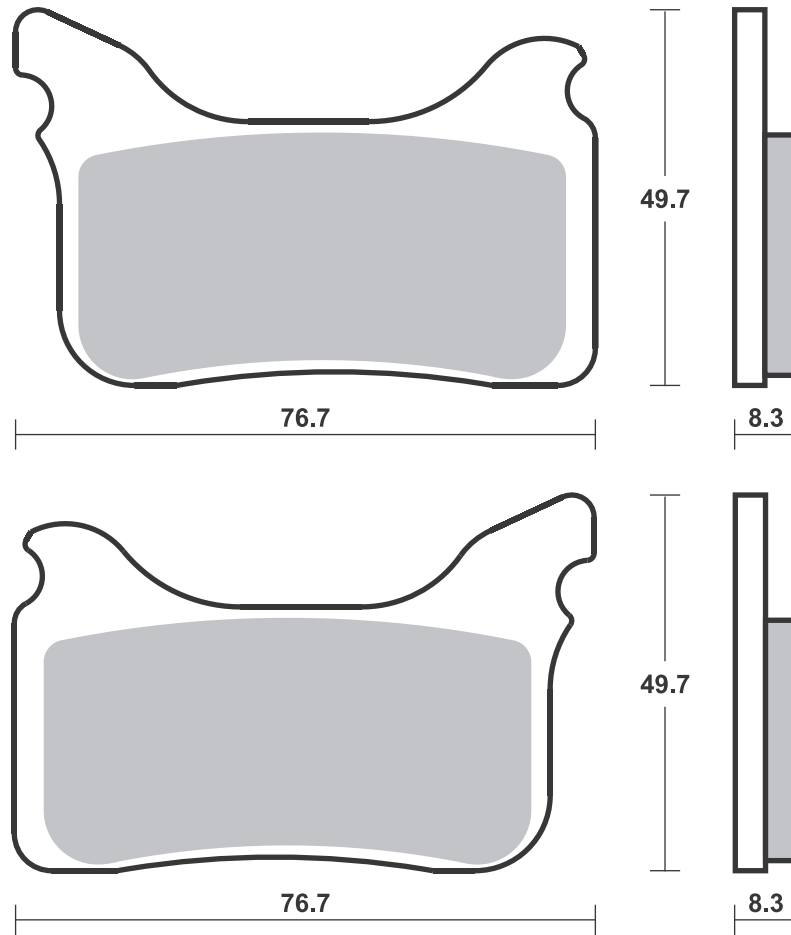

Available compounds

HS • DC • RST • RSI

SBS 843

1 set = 4 pcs.

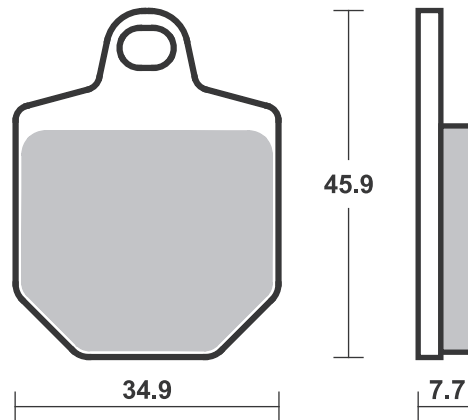



Available compounds

**HF • HS • DC • RST**

**SBS 844**

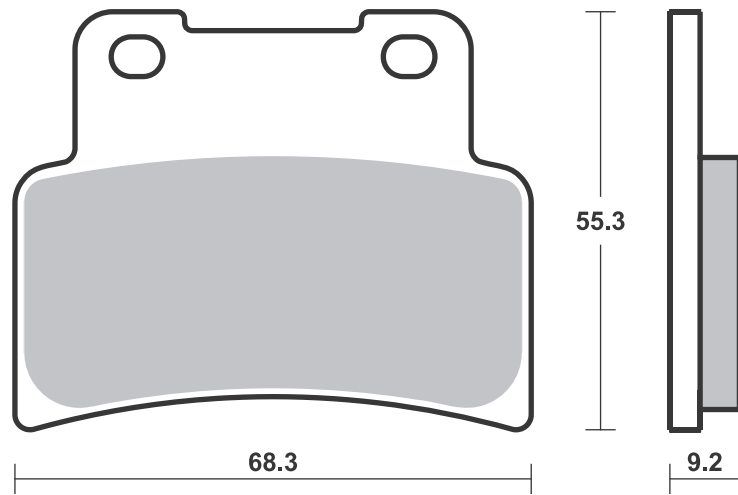

Available compounds

**DC • DS-1 • DS-2**

**SBS 845**

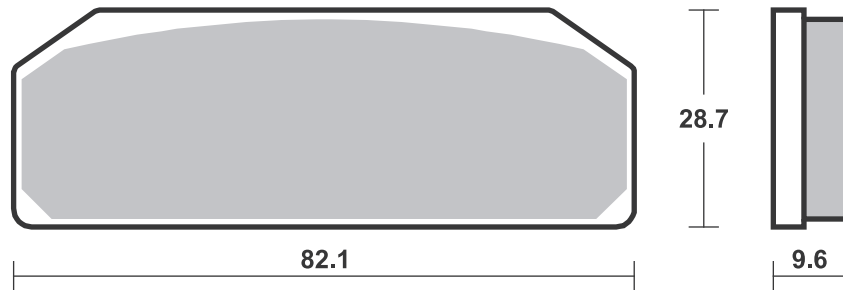



Available compounds

**H.HF • H.CT • H.LS**

**SBS 846**

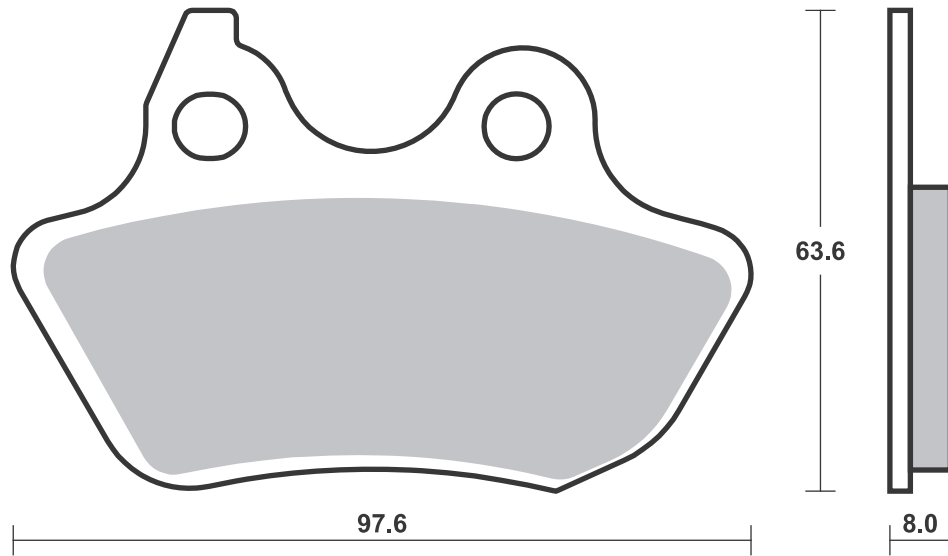
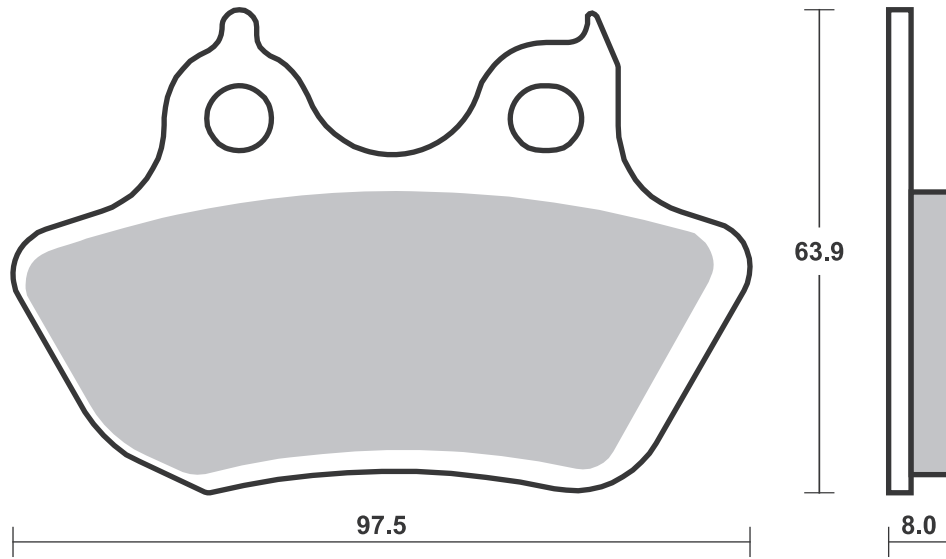

Available compounds

**HF • HS • SI • RSI**

**SBS 847**

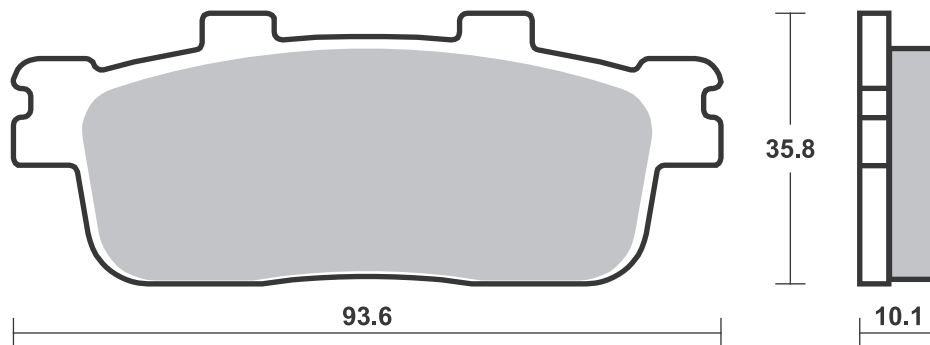

Brake Pad 1:1 Drawings,  
Compounds, Fitsments

# Applications

## SBS 848 Recommended compound



### ADLY

ATV	300 Sport	07-13	SI
-----	-----------	-------	----

### CPI

XS	250 Quad	06-08	SI
----	----------	-------	----

## SBS 849 Recommended compound



### YAMAHA

YFM	250 Raptor	09-14	SI
-----	------------	-------	----

YFM	550 FGPW Grizzly	09-16	SI
-----	------------------	-------	----

YFM	700 FGPW Grizzly	07-17	SI
-----	------------------	-------	----

Brake Pad 1:1 Drawings,  
Compounds, Fitments

Available compounds

HF • SI

SBS 848

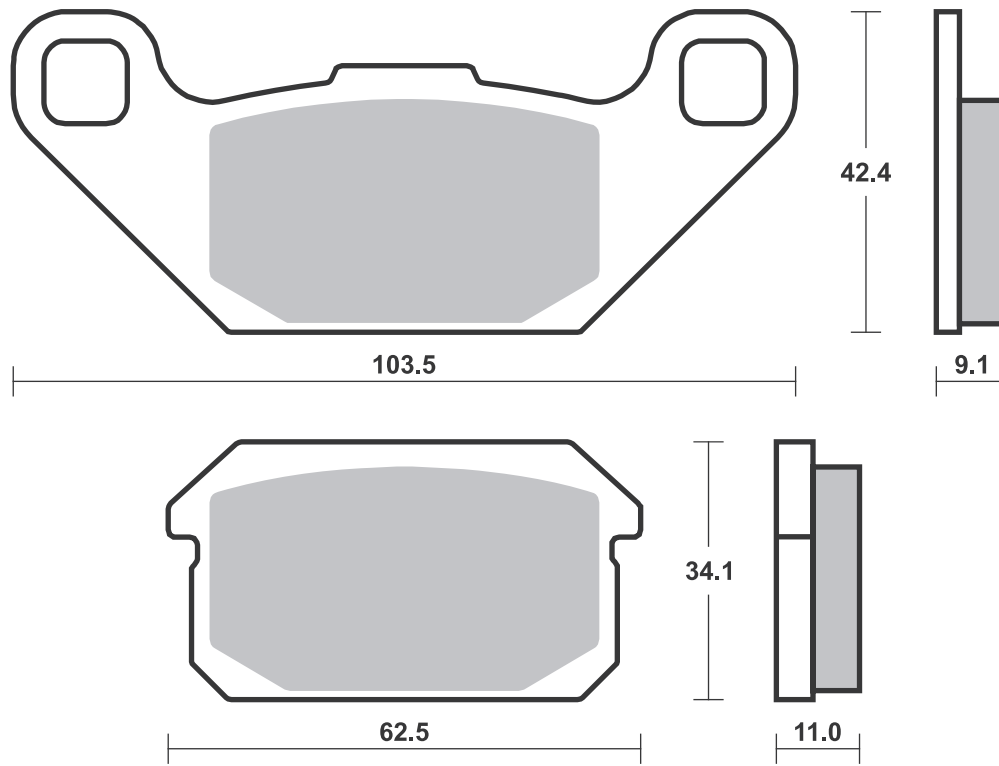

Available compounds

SI • RSI

SBS 849

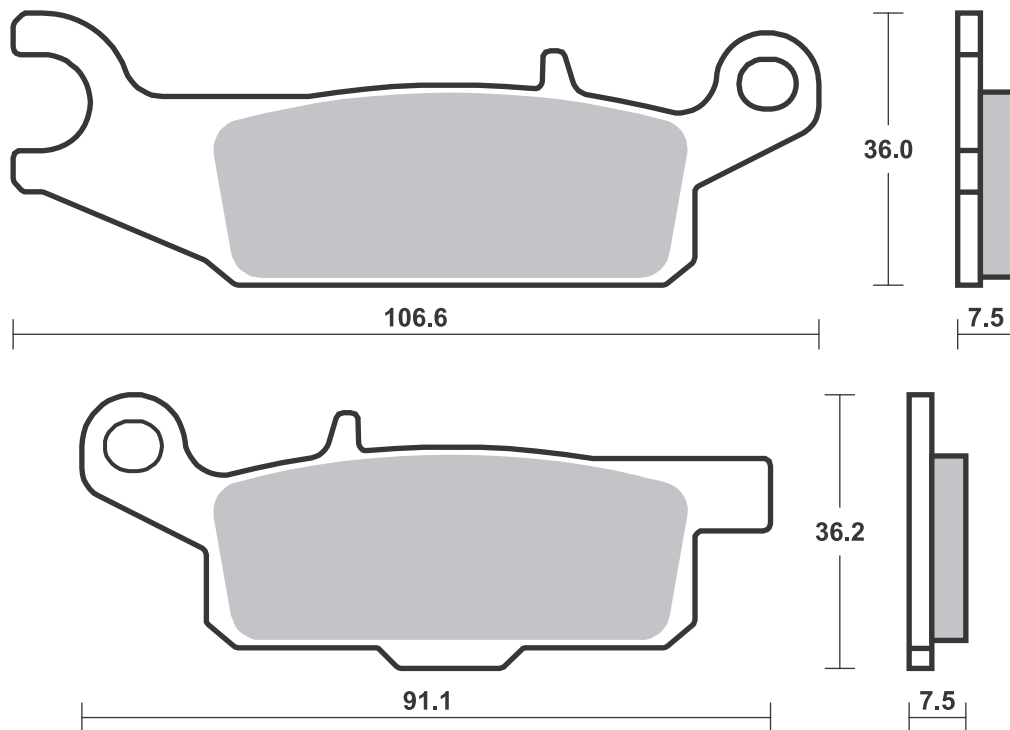





Available compounds

SI • RSI

SBS 850

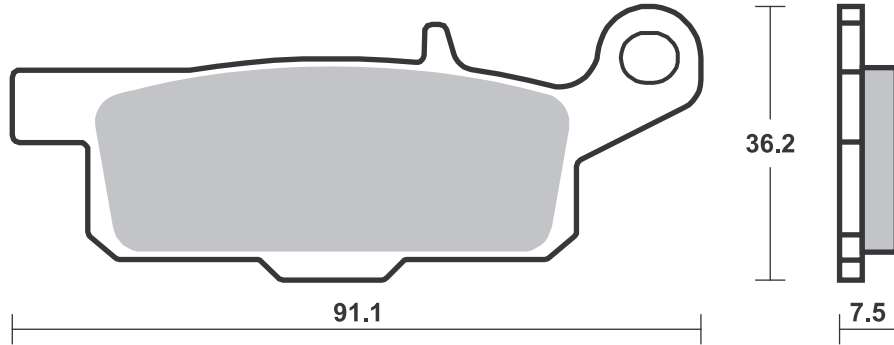
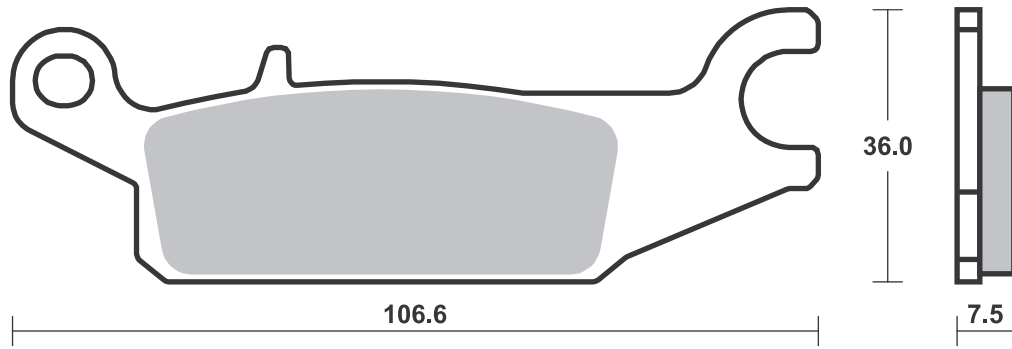

Available compounds

SI • RSI

SBS 851

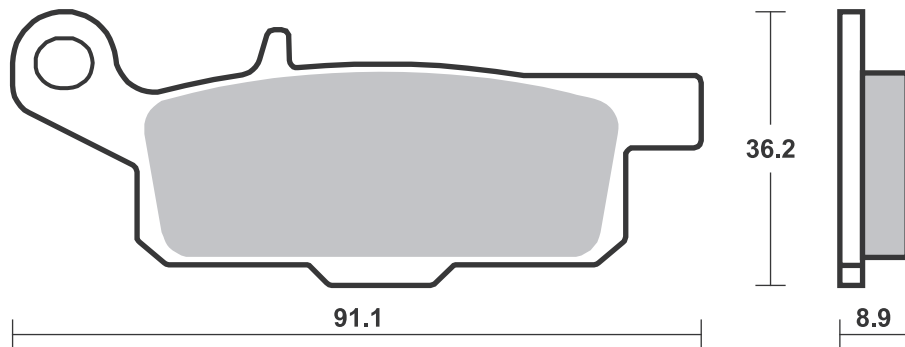
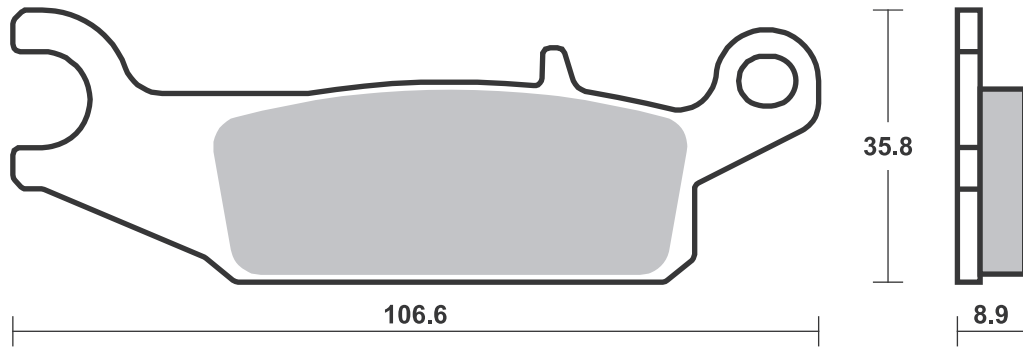



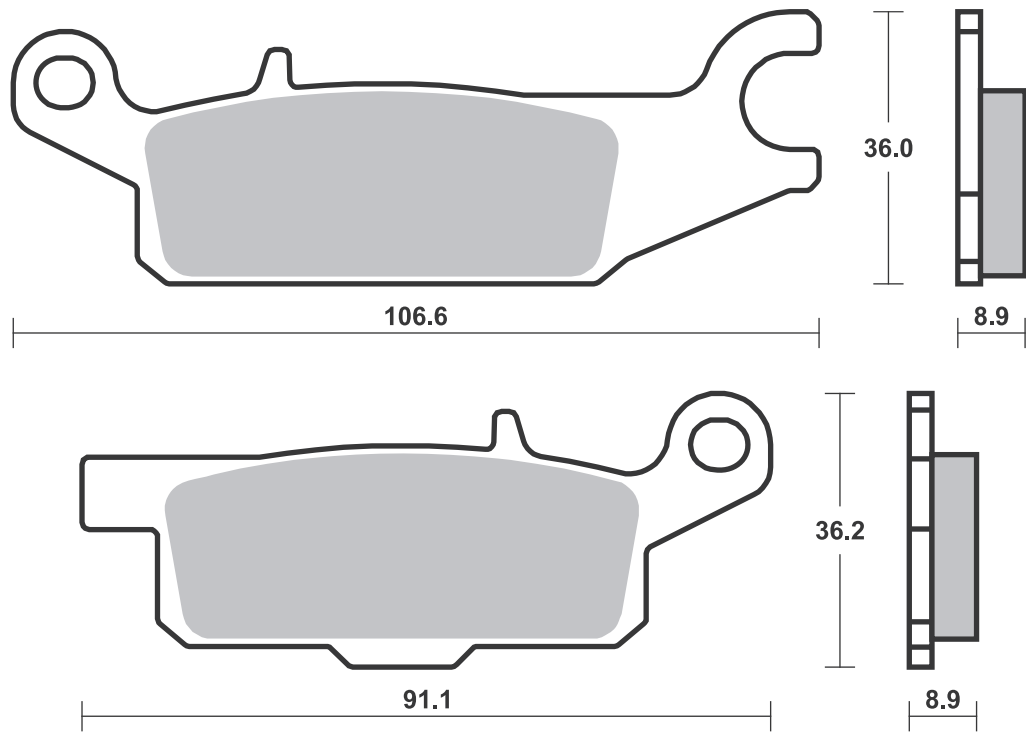



HARLEY DAVIDSON			
FLSTC	1584	Heritage	
		Softail	
		Classic	08-11 <b>H.HS</b>
FLSTF	1584	Fat Boy	08-11 <b>H.HS</b>
FLSTFB	1584	Fat Boy	
		Special	10-11 <b>H.HS</b>
FLSTN	1584	Softail	
		Deluxe	08-11 <b>H.HS</b>
FXCW	1584	Rocker	08-09 <b>H.HS</b>
FXCWC	1584	Rocker C	08-13 <b>H.HS</b>
FXD	1584	Dyna	
		Super	
		Glide	08-10 <b>H.HS</b>
FXDB	1584	Dyna	
		Street Bob	08-13 <b>H.HS</b>
FXDC	1584	Dyna	
		Super	
		Glide	
		Custom	08-13 <b>H.HS</b>
FXDF	1584	Fat Bob	08-11 <b>H.HS</b>
FXDL	1584	Dyna Low	
		Rider	08-13 <b>H.HS</b>
FXDWG	1584	Dyna Wide	
		Glide	08-10 <b>H.HS</b>
FXST	1584	Softail	
		Standard	08-14 <b>H.HS</b>
FXSTB	1584	Night Train	08-09 <b>H.HS</b>
FXSTC	1584	Softail	
		Custom	08-10 <b>H.HS</b>
FLD	1690	Switchback	12-16 <b>H.HS</b>
FLHTC	1690	Electra	
		Glide	
		Classic	11-16 <b>H.HS</b>
FLHTK	1690	Ultra Electra	
		Glide	11-16 <b>H.HS</b>
FLS	1690	Softail Slim	12-14 <b>H.HS</b>
FLSTC	1690	Heritage	
		Softail	
		Classic	12-14 <b>H.HS</b>
FLSTF	1690	Fat Boy	12-14 <b>H.HS</b>
FLSTF	1690	Fat Boy	
		Special	12-14 <b>H.HS</b>
FLSTFB	1690	Fat Boy	12-14 <b>H.HS</b>
FLSTN	1690	Softail	
		Deluxe	12-14 <b>H.HS</b>
FXDB	1690	Dyna	
		Street Bob	14-17 <b>H.HS</b>
FXDBA	1690	Dyna	
		Street Bob	13-17 <b>H.HS</b>
FXDBB	1690	Dyna	
		Street Bob	14-17 <b>H.HS</b>
FXDBP	1690	Dyna	
		Street Bob	13-17 <b>H.HS</b>
FXDC	1690	Dyna Super	
		Glide	
		Custom	14-14 <b>H.HS</b>
FXDF	1690	Dyna Wide	
		Glide	12-17 <b>H.HS</b>
FXDF	1690	Fat Bob	12-17 <b>H.HS</b>
FXDL	1690	Dyna Low	
		Rider	14-17 <b>H.HS</b>
FXDLS	1690	Dyna Low	
		Rider S	17-17 <b>H.HS</b>
FXS	1690	Blackline	13-17 <b>H.HS</b>
FXSB	1690	Breakout	14-14 <b>H.HS</b>
FLSTNSE	1802	CVO Softail	
		Deluxe	14-14 <b>H.HS</b>



HARLEY DAVIDSON			
FXSBSE	1802	CVO	
		Breakout	13-14 <b>H.HS</b>

Available compounds

**H.HF • H.CT • H.HS**

**SBS 853**

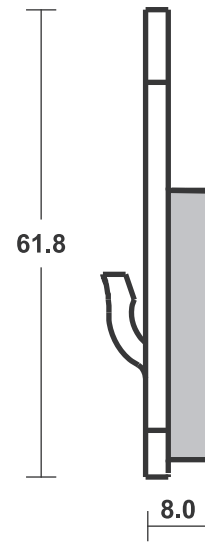
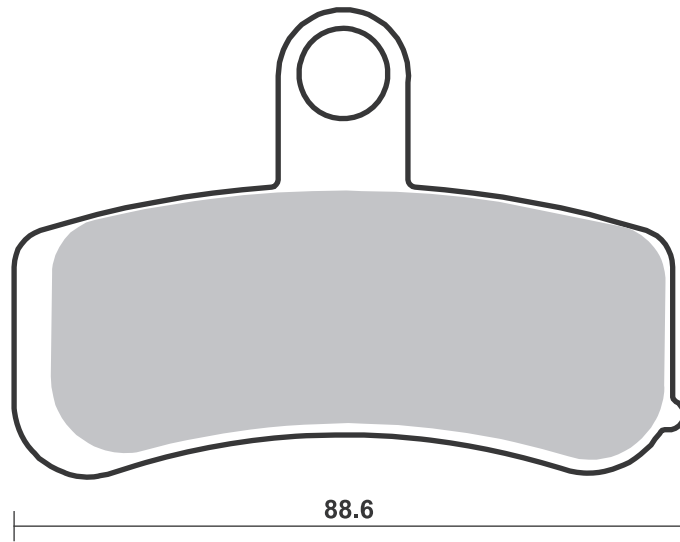
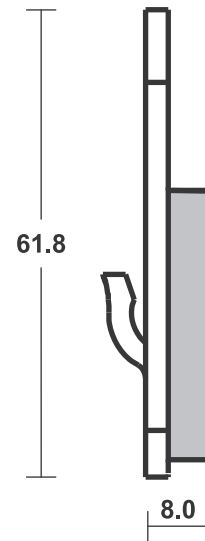
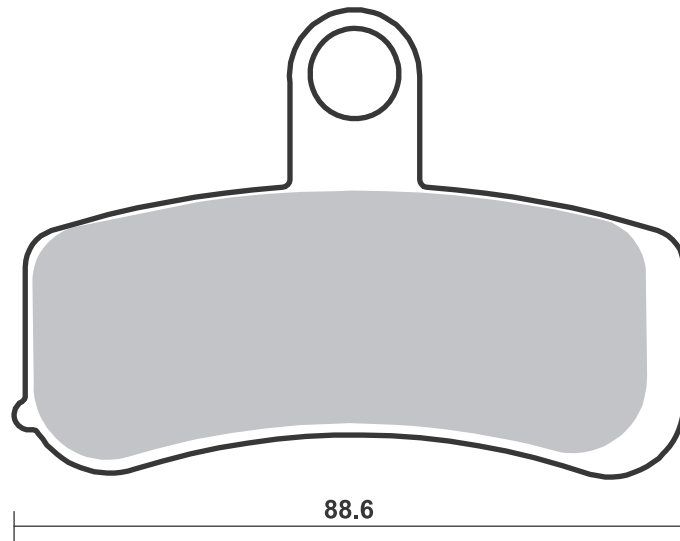

**SBS 854** Recommended compound



<b>HARLEY DAVIDSON</b>			
FLSTC	1584	Heritage	
		Softail	
		Classic	08-11 <b>H.LS</b>
FLSTF	1584	Fat Boy	08-11 <b>H.LS</b>
FLSTFB	1584	Fat Boy	
		Special	10-11 <b>H.LS</b>
FLSTN	1584	Softail	
		Deluxe	08-11 <b>H.LS</b>
FXCW	1584	Rocker	08-09 <b>H.LS</b>
FXCWC	1584	Rocker C	08-13 <b>H.LS</b>
FXD	1584	Dyna Super	
		Glide	08-10 <b>H.LS</b>
FXDB	1584	Dyna	
		Street Bob	08-13 <b>H.LS</b>
FXDC	1584	Dyna	
		Super Glide	
		Custom	08-13 <b>H.LS</b>
FXDF	1584	Fat Bob	08-11 <b>H.LS</b>
FXDL	1584	Dyna Low	
		Rider	08-13 <b>H.LS</b>
FXDWG	1584	Dyna Wide	
		Glide	08-10 <b>H.LS</b>
FXST	1584	Softail	
		Standard	08-17 <b>H.LS</b>
FXSTB	1584	Night Train	08-09 <b>H.LS</b>
FXSTC	1584	Softail	
		Custom	08-10 <b>H.LS</b>
FLD	1690	Switchback	12-16 <b>H.LS</b>
FLHTC	1690	Electra	
		Glide	
		Classic	11-16 <b>H.LS</b>
FLHTK	1690	Ultra Electra	
		Glide	11-16 <b>H.LS</b>
FLS	1690	Softail Slim	12-17 <b>H.LS</b>



<b>HARLEY DAVIDSON</b>			
FLSTC	1690	Heritage	
		Softail	
		Classic	12-17 <b>H.LS</b>
FLSTF	1690	Fat Boy	12-17 <b>H.LS</b>
FLSTFB	1690	Fat Boy	
		Special	12-14 <b>H.LS</b>
FLSTFB	1690	Fat Boy	12-17 <b>H.LS</b>
FLSTN	1690	Softail	
		Deluxe	12-17 <b>H.LS</b>
FXDB	1690	Dyna	
		Street Bob	14-17 <b>H.LS</b>
FXDBA	1690	Dyna	
		Street Bob	13-17 <b>H.LS</b>
FXDBB	1690	Dyna	
		Street Bob	14-17 <b>H.LS</b>
FXDBP	1690	Dyna	
		Street Bob	13-17 <b>H.LS</b>
FXDC	1690	Dyna Super	
		Glide	
		Custom	14-14 <b>H.LS</b>
FXDF	1690	Dyna Wide	
		Glide	12-17 <b>H.LS</b>
FXDF	1690	Fat Bob	12-17 <b>H.LS</b>
FXDL	1690	Dyna Low	
		Rider	14-17 <b>H.LS</b>
FXDLS	1690	Dyna Low	
		Rider S	17-17 <b>H.LS</b>
FXS	1690	Blackline	13-17 <b>H.LS</b>
FXSB	1690	Breakout	14-17 <b>H.LS</b>
FLSS	1802	Softail Slim	
		S	16-17 <b>H.LS</b>
FLSTFBS	1802	Fat Boy S	16-17 <b>H.LS</b>
FLSTNSE	1802	CVO Softail	
		Deluxe	14-17 <b>H.LS</b>



<b>HARLEY DAVIDSON</b>			
FXSBSE	1802	CVO	
		Breakout	13-14 <b>H.LS</b>

**SBS 856** Recommended compound



<b>BUELL</b>			
	1125	CR	09-10 <b>HS</b>
	1125	R	08-10 <b>HS</b>
XB12R	1200	Firebolt	09-10 <b>HS</b>
XB12Scg	1200	Lightning	09-10 <b>HS</b>
XB12Ss	1200	Lightning	
		Long	09-10 <b>HS</b>

<b>EBR</b>			
	1190	RS	12-15 <b>HS</b>
	1190	RX	14-15 <b>HS</b>
	1190	SX	14-15 <b>HS</b>

Brake Pad 1:1 Drawings, Compounds, Fitments

Available compounds

**H.HF • H.CT • H.LS**

**SBS 854**

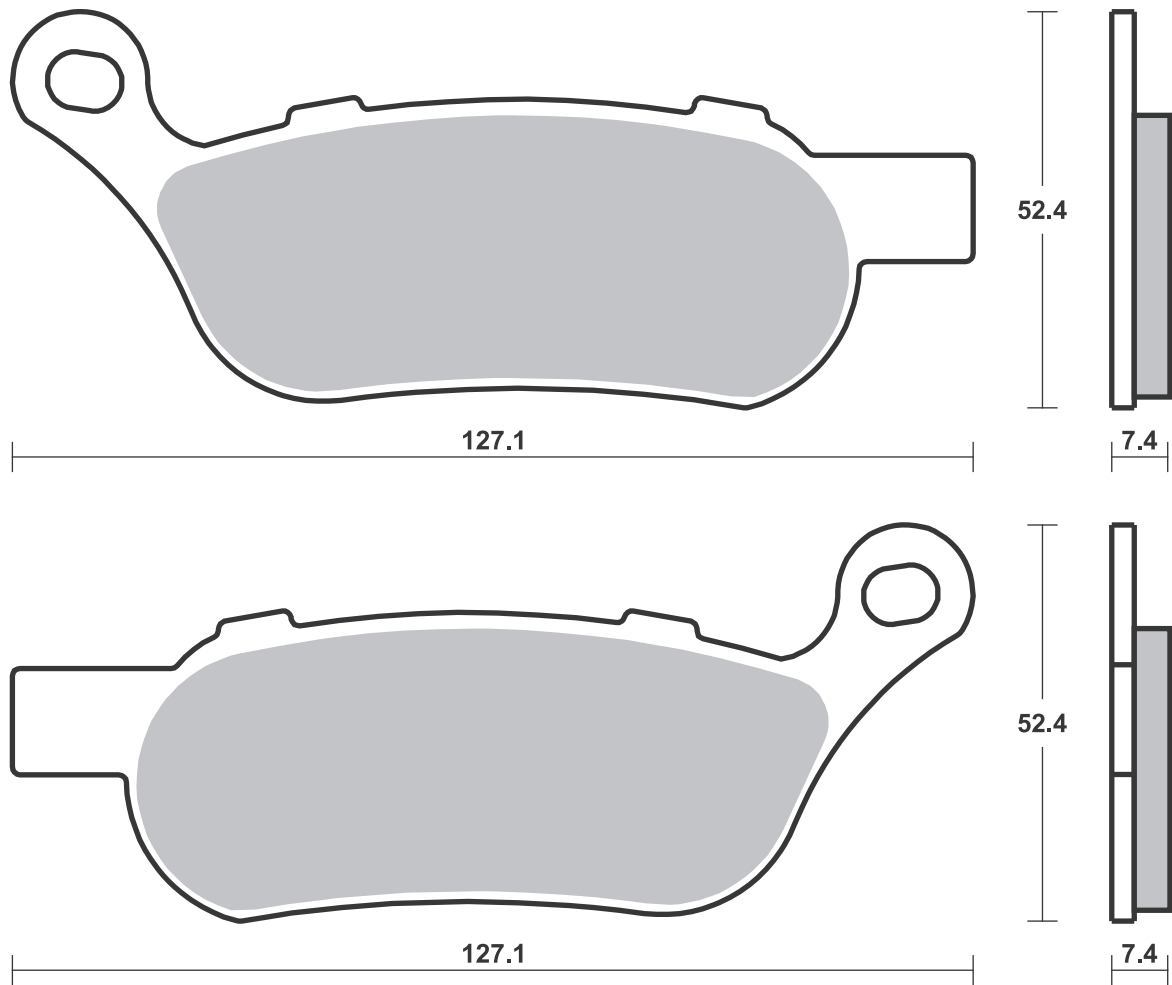

Available compounds

**HS • RST • DS-1**

**SBS 856**

1 set = 4 pcs.

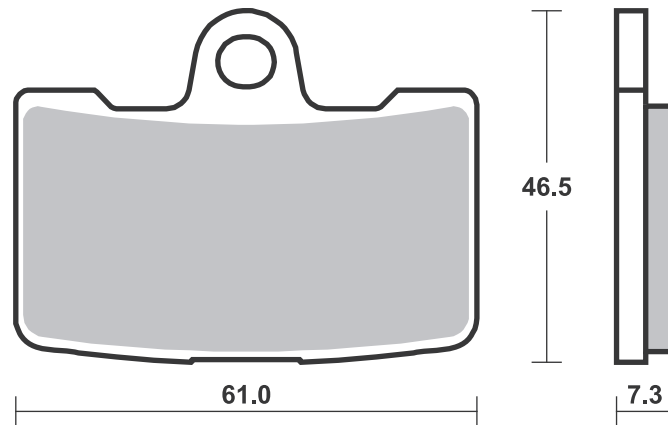





Available compounds

LS

SBS 857

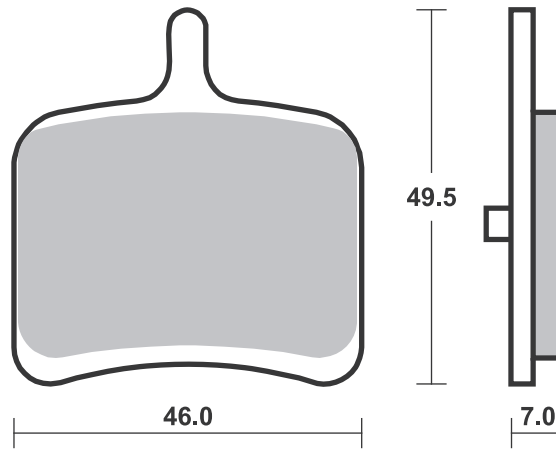

Available compounds

HF

SBS 858

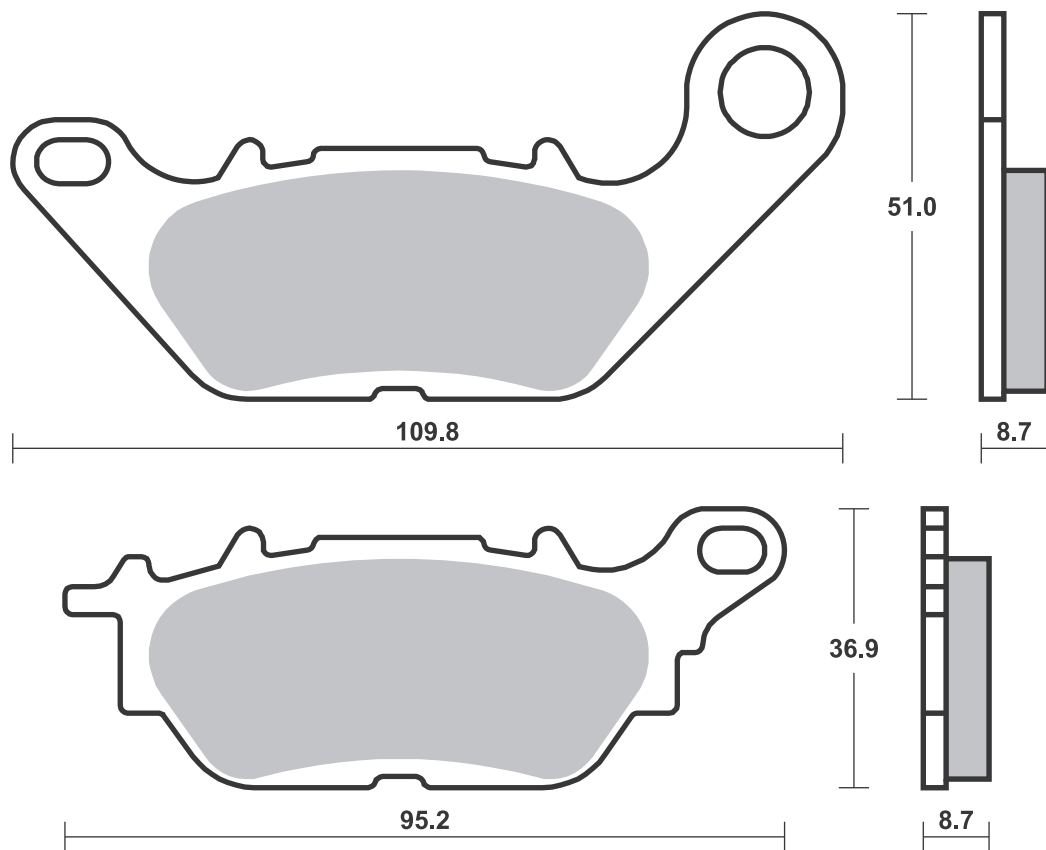



Available compounds

HF • SI • RSI

SBS 859

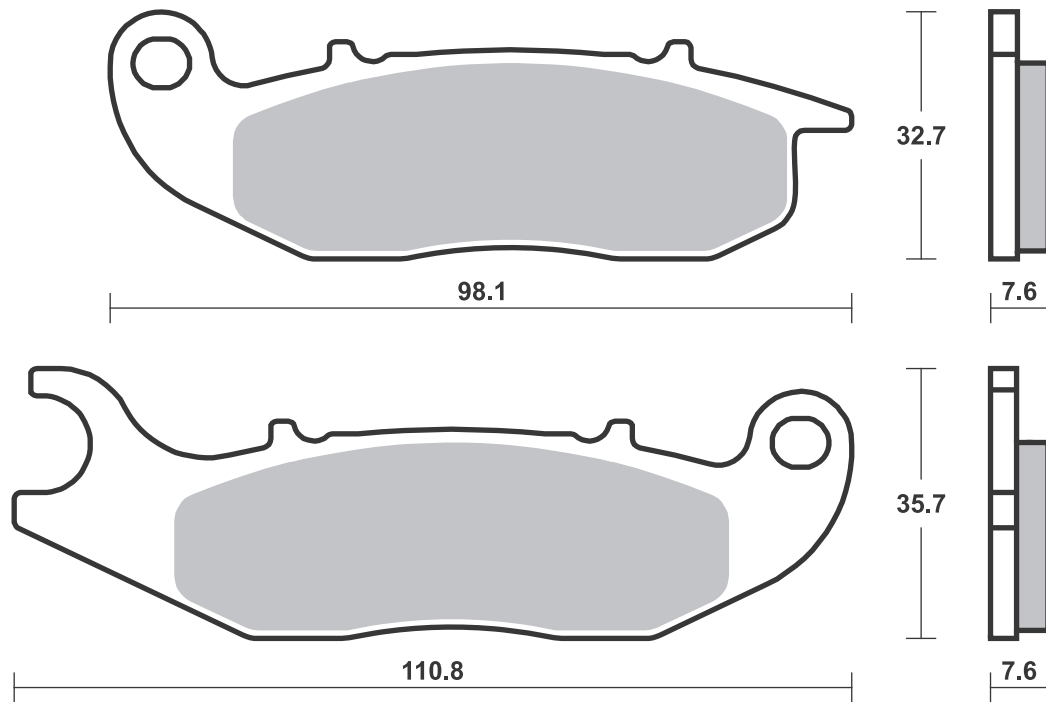

Available compounds

SP • DS-1 • DS-2 • MS • H.HF • H.CT • H.HS

SBS 860

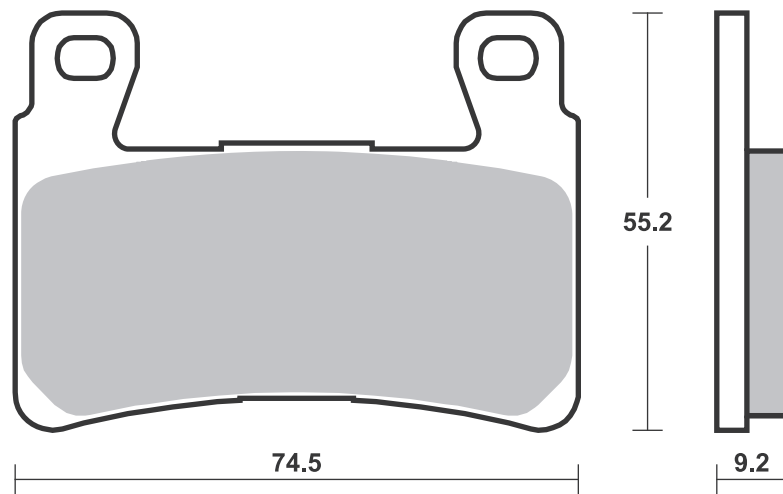



Available compounds

HF

SBS 861

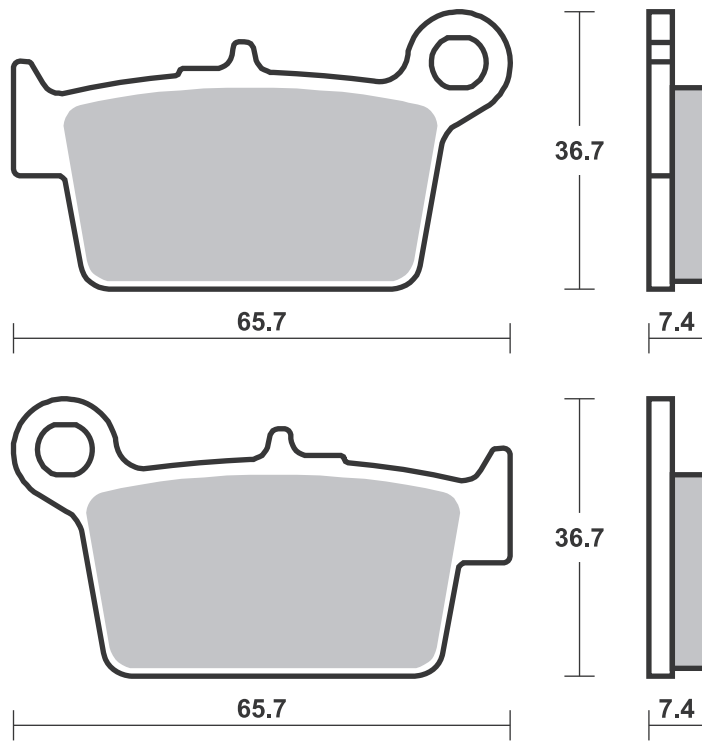

Available compounds

HF • LS

SBS 862

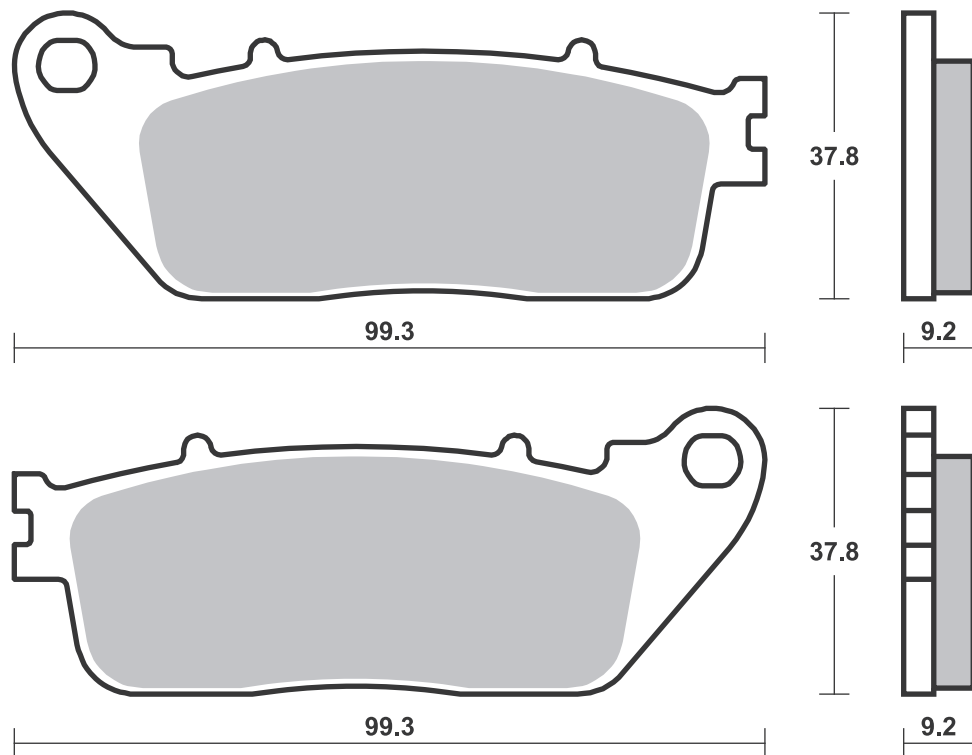

# Applications

## SBS 864 Recommended compound



### TRIUMPH

675 Daytona Triple 09- 18 **HS**

## SBS 865 Recommended compound



### NISSIN

6 Piston Racing Radial  
Monobloc Caliper (Z0901)

## SBS 866 Recommended compound



### KTM

SX 450 ATV 08- 10 **RSI**  
XC 450 ATV 08- 10 **SI**  
SX 505 ATV 08- 12 **RSI**  
XC 505 ATV 08- 12 **SI**

Brake Pad 1:1 Drawings,  
Compounds, Fitments

Available compounds

HS • SP • DC • RST

SBS 864

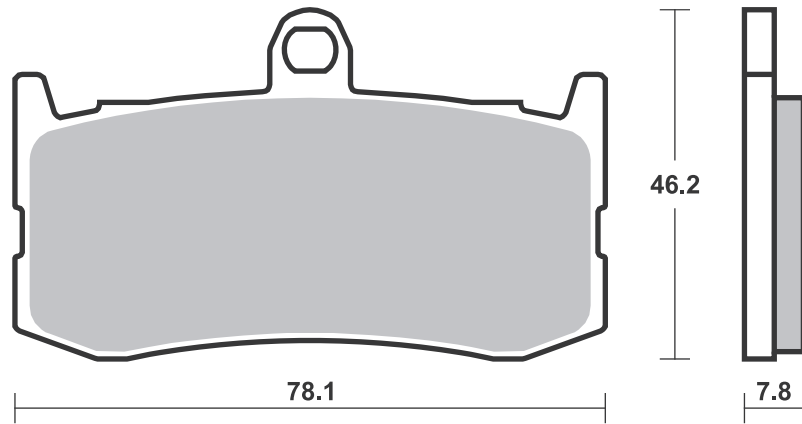

Available compounds

DS-1

SBS 865

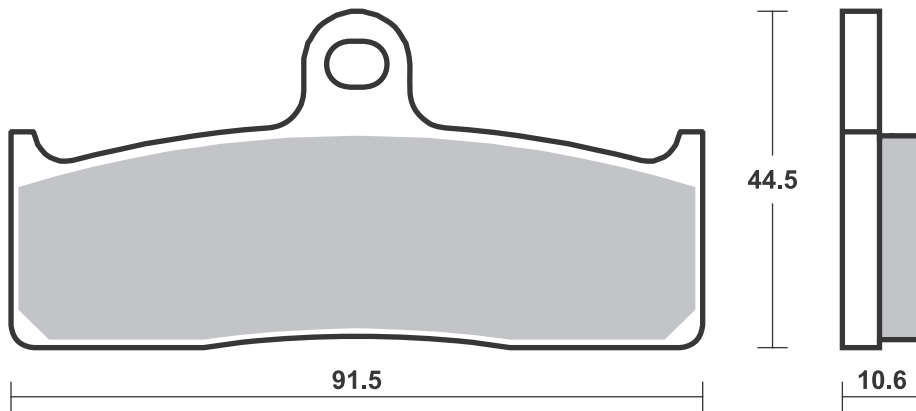

Available compounds

SI • RSI

SBS 866

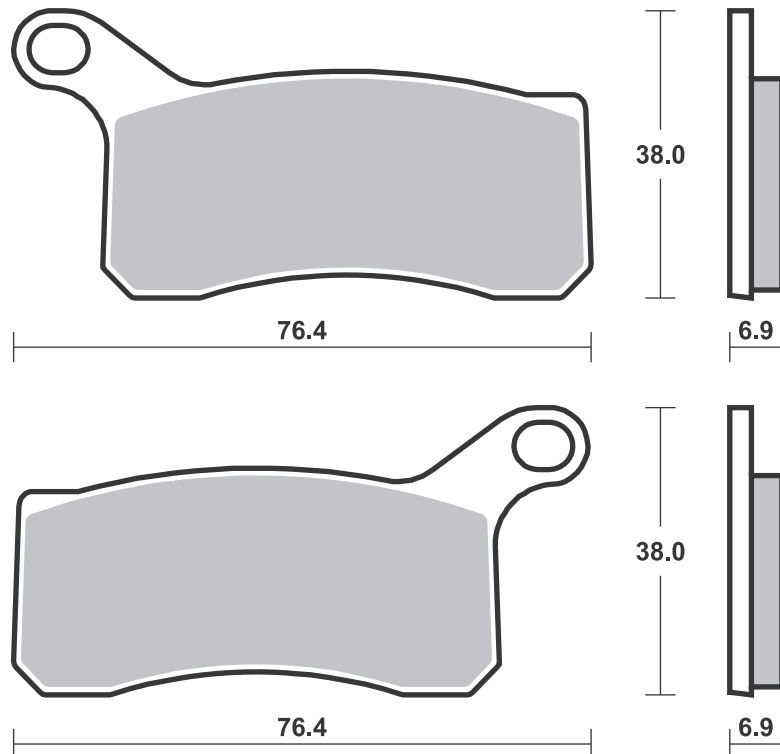





Available compounds

SI • RSI

SBS 867

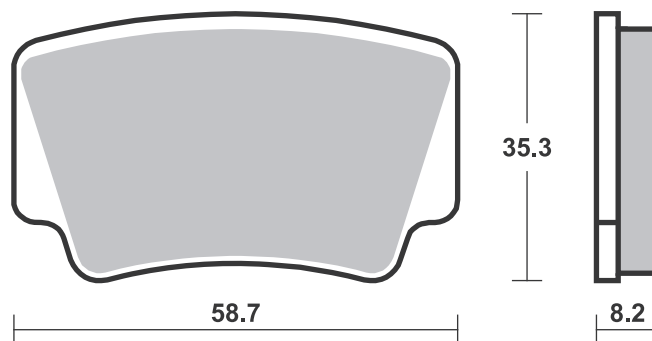

Available compounds

HS • SP

SBS 869

1 set = 2 pcs. large / small

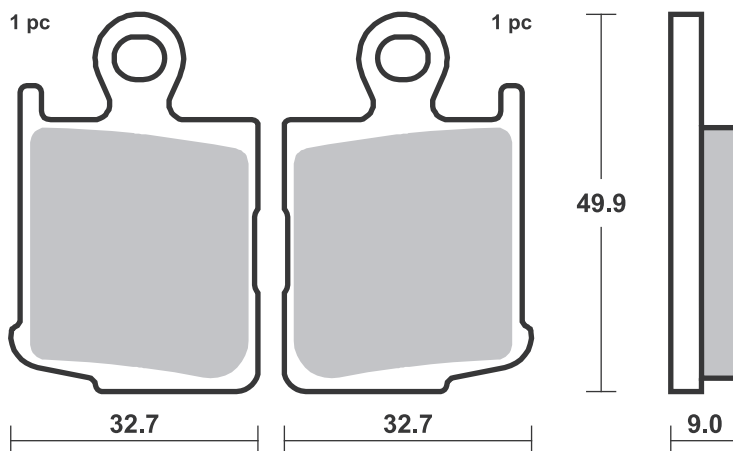
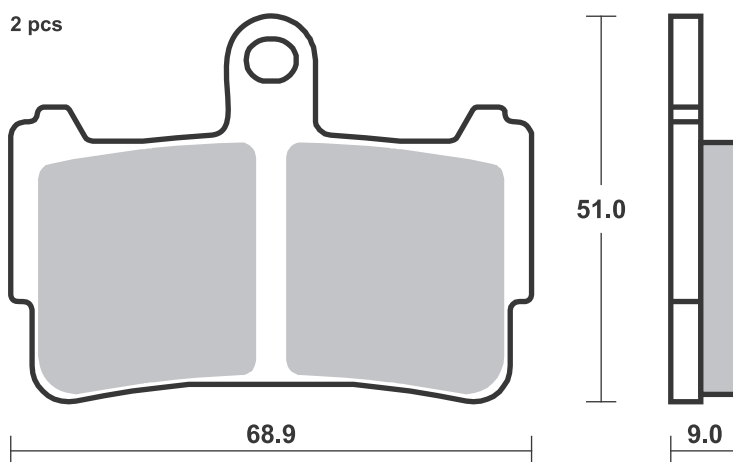



Available compounds

HS • SP • DC • RST • DS-1 • DS-2

SBS 870

1 set = 4 pcs.

HS / SP - Th. 8.0

RST / DC / DS - Th. 8.7

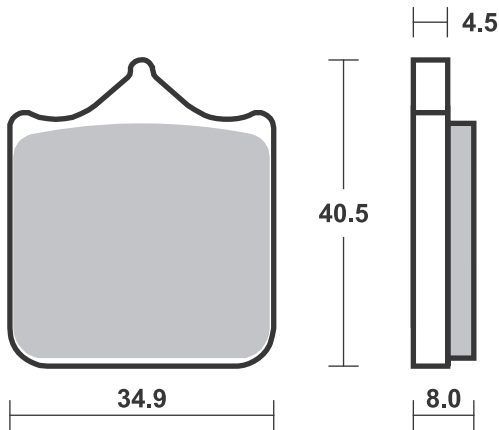

Available compounds

RST • RQ • CS • SI • RSI

SBS 872

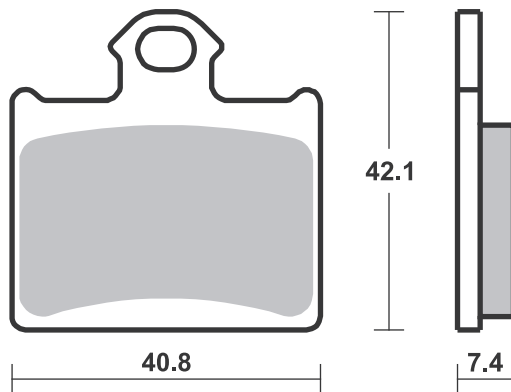



Available compounds

HF

SBS 873

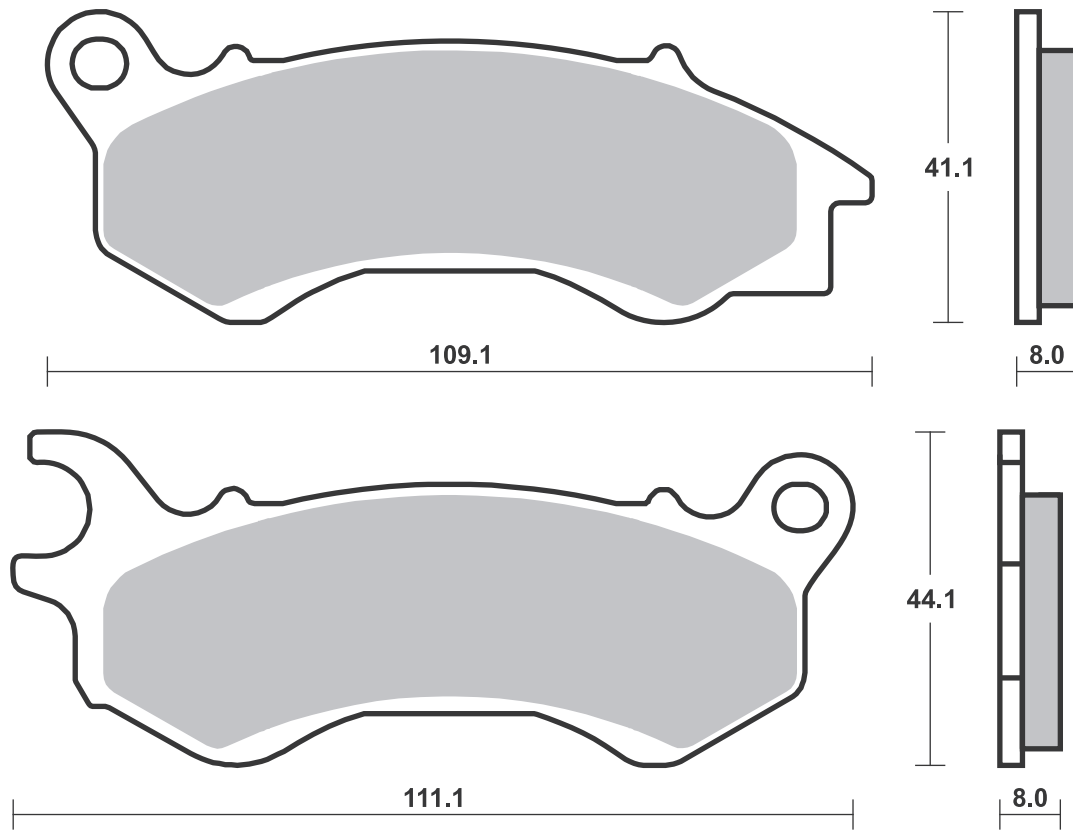

Available compounds

HF • HS • DC • RST

SBS 877

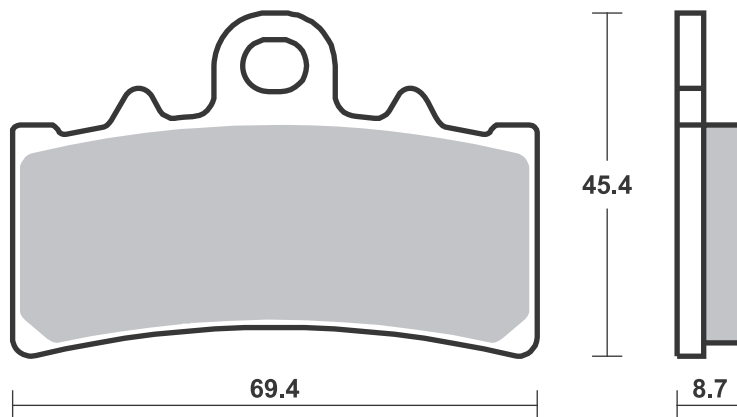



Available compounds

HF • SI • RSI

SBS 878

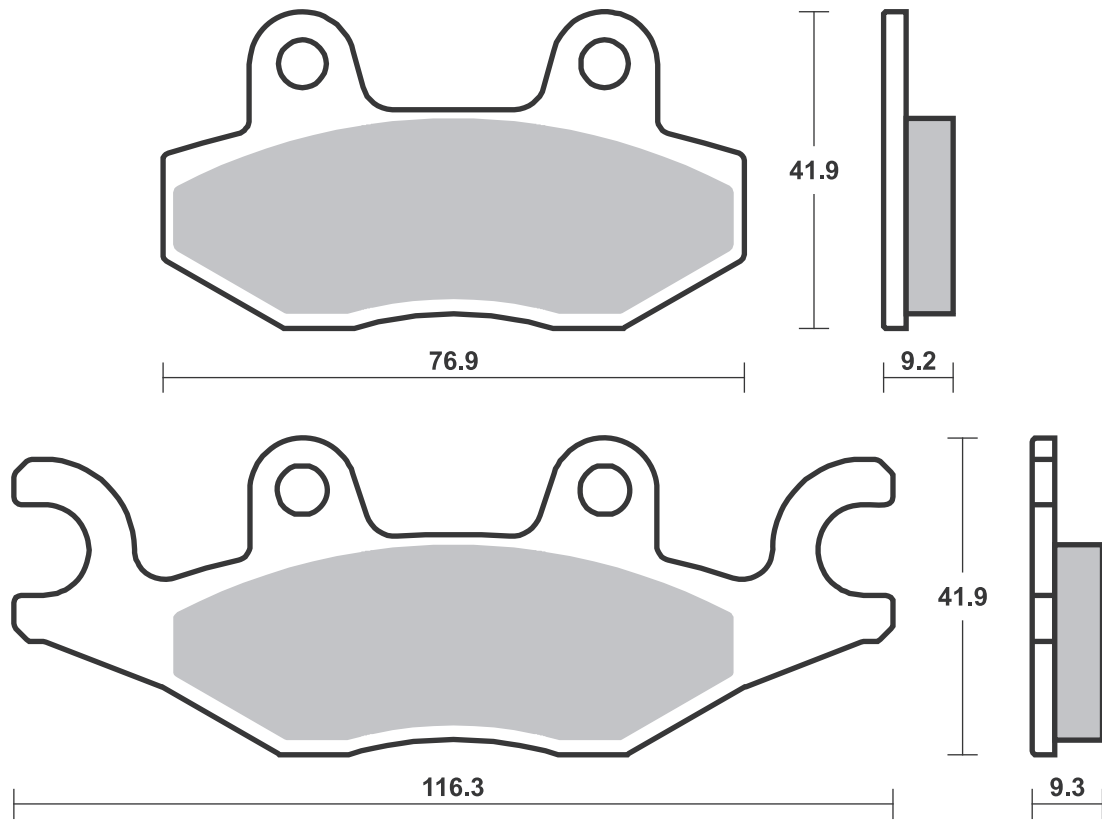

Available compounds

HF

SBS 879

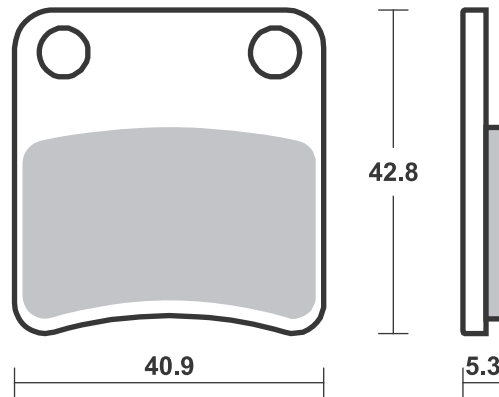

Brake Pad 1:1 Drawings,  
Compounds, Fitments





Available compounds

LS

SBS 880

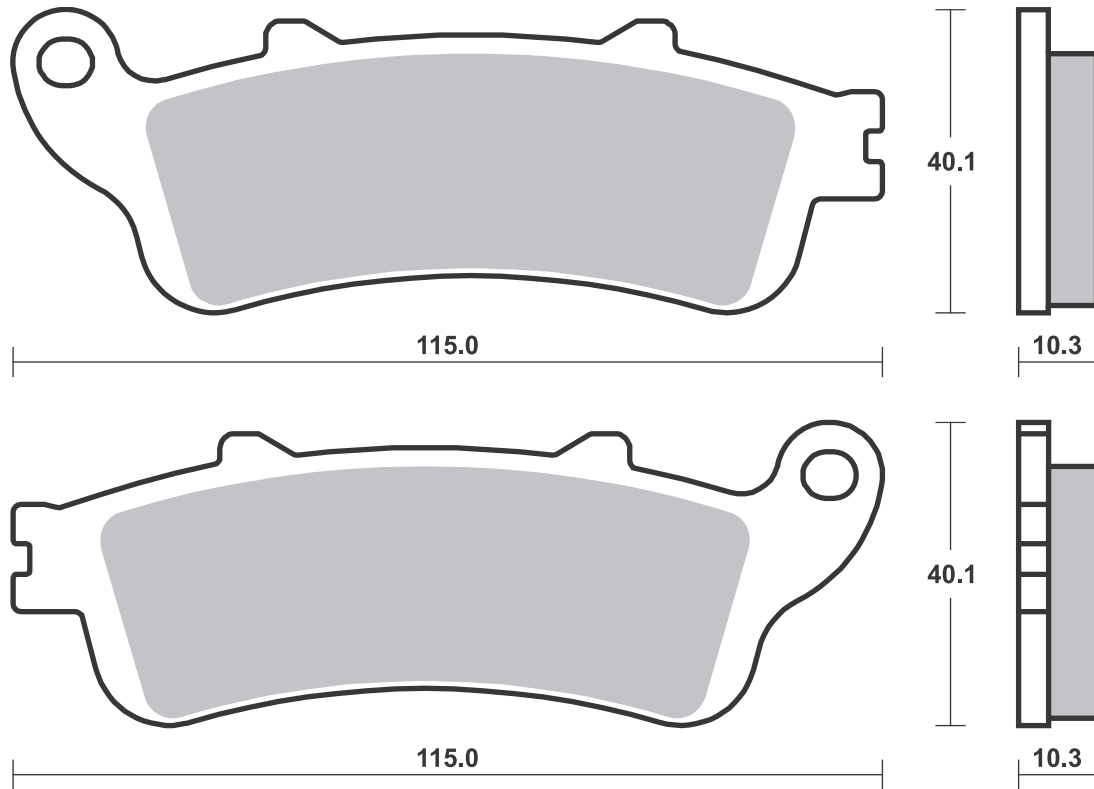

Available compounds

HF • LS • RQ

SBS 881

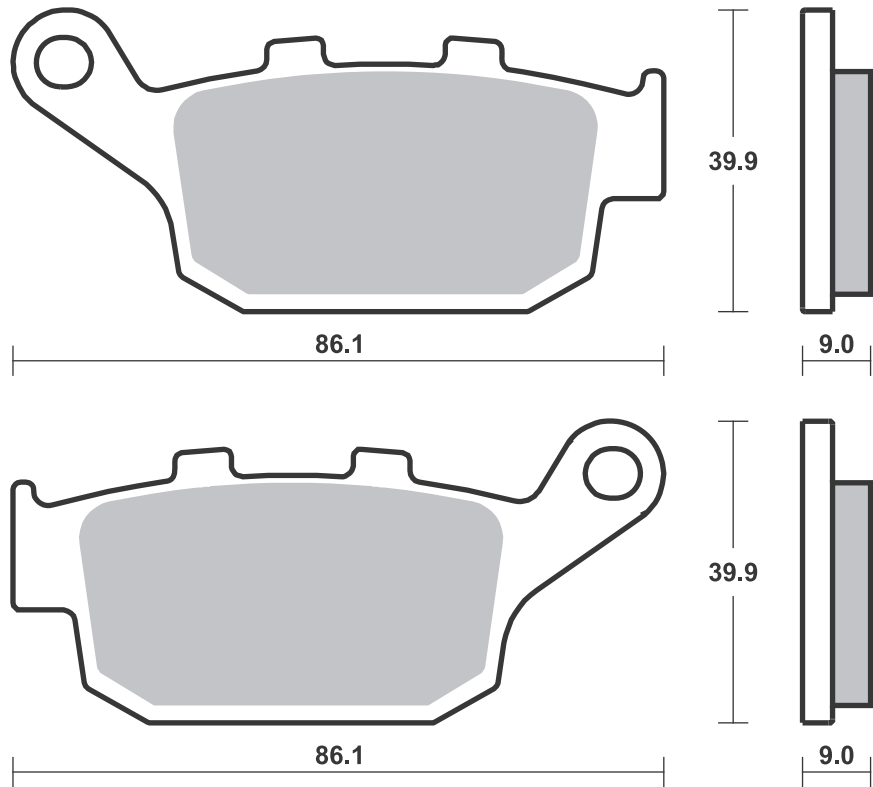

## Applications

### SBS 885 Recommended compound



<b>GAS GAS</b>			
TXT	125 (Formula cal.)	12- 13	<b>RSI</b>
TXT	250 (Formula cal.)	12- 13	<b>RSI</b>
TXT	280 (Formula cal.)	12- 12	<b>RSI</b>
TXT	300 (Formula cal.)	12- 12	<b>RSI</b>

<b>HUSQVARNA</b>			
TC	85	14- 20	<b>RSI</b>

<b>KTM</b>			
	Freeride		
	Electric	12- 14	<b>RSI</b>
E-SM	Freeride	15- 16	<b>RSI</b>
E-SX	Freeride	15- 16	<b>RSI</b>
E-XC	Freeride	15- 22	<b>RSI</b>
SX	85	12- 20	<b>RSI</b>
SX	85 (19"/		
	16" wheels)	13- 20	<b>RSI</b>
	250 Freeride R	14- 19	<b>RSI</b>
	350 Freeride	12- 17	<b>RSI</b>

<b>OHVALE</b>			
GP-01	110	17- 19	<b>RST</b>
GP-01	160	17- 19	<b>RST</b>
GP-01	190	17- 19	<b>RST</b>

<b>SHERCO</b>			
ST	80 (Formula cal.)	13- 14	<b>RSI</b>
ST	125 (Formula cal.)	13- 14	<b>RSI</b>
ST	250 (Formula cal.)	13- 14	<b>RSI</b>
ST	290 (Formula cal.)	13- 14	<b>RSI</b>



<b>SHERCO</b>			
ST	305 (Formula cal.)	13- 14	<b>RSI</b>

### SBS 886 Recommended compound



<b>KAWASAKI</b>			
VN	900 Vulcan Classic	06- 16	<b>LS</b>
VN	900 Vulcan Classic		
	SE	11- 16	<b>LS</b>
VN	900 Vulcan Custom	07- 16	<b>LS</b>
KZ	1000 Police	02- 03	<b>LS</b>
VN	1500 Mean Streak	02- 03	<b>LS</b>
VN	1500 Vulcan Classic		
	Fi	00- 04	<b>LS</b>
VN	1500 Vulcan Nomad		
	Fi	00- 04	<b>LS</b>
VN	1600 Mean Streak	04- 05	<b>LS</b>
VN	1600 Nomad	05- 05	<b>LS</b>
VN	1600 Vulcan Classic	03- 08	<b>LS</b>
VN	1700 Voyager		
	Vaquero	09- 14	<b>LS</b>
VN	1700 Vulcan Classic	09- 14	<b>LS</b>
VN	1700 Vulcan Nomad	09- 16	<b>LS</b>
VN	1700 Vulcan Voyager	09- 16	<b>LS</b>
VN	2000 Vulcan	04- 10	<b>LS</b>

<b>SUZUKI</b>			
C	1500 T Intruder	13- 18	<b>LS</b>
C90	1500 Boulevard		
	B.O.S.S.	13- 18	<b>LS</b>
M90	1500	09- 18	<b>LS</b>
M95	1600 Boulevard	05- 07	<b>LS</b>
VZ	1600 Marauder	04- 04	<b>LS</b>

Available compounds

**RST • CS • SI • RSI**

**SBS 885**

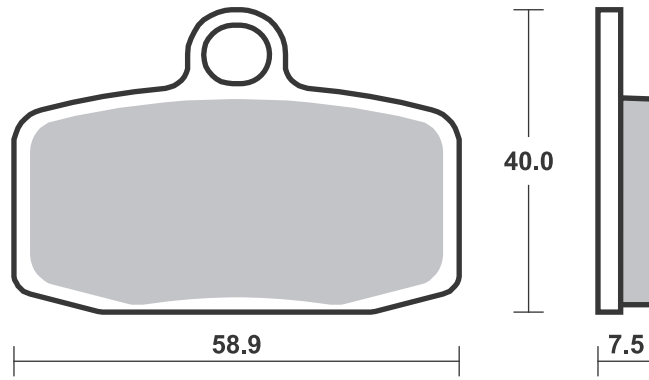

Available compounds

**HF • LS**

**SBS 886**

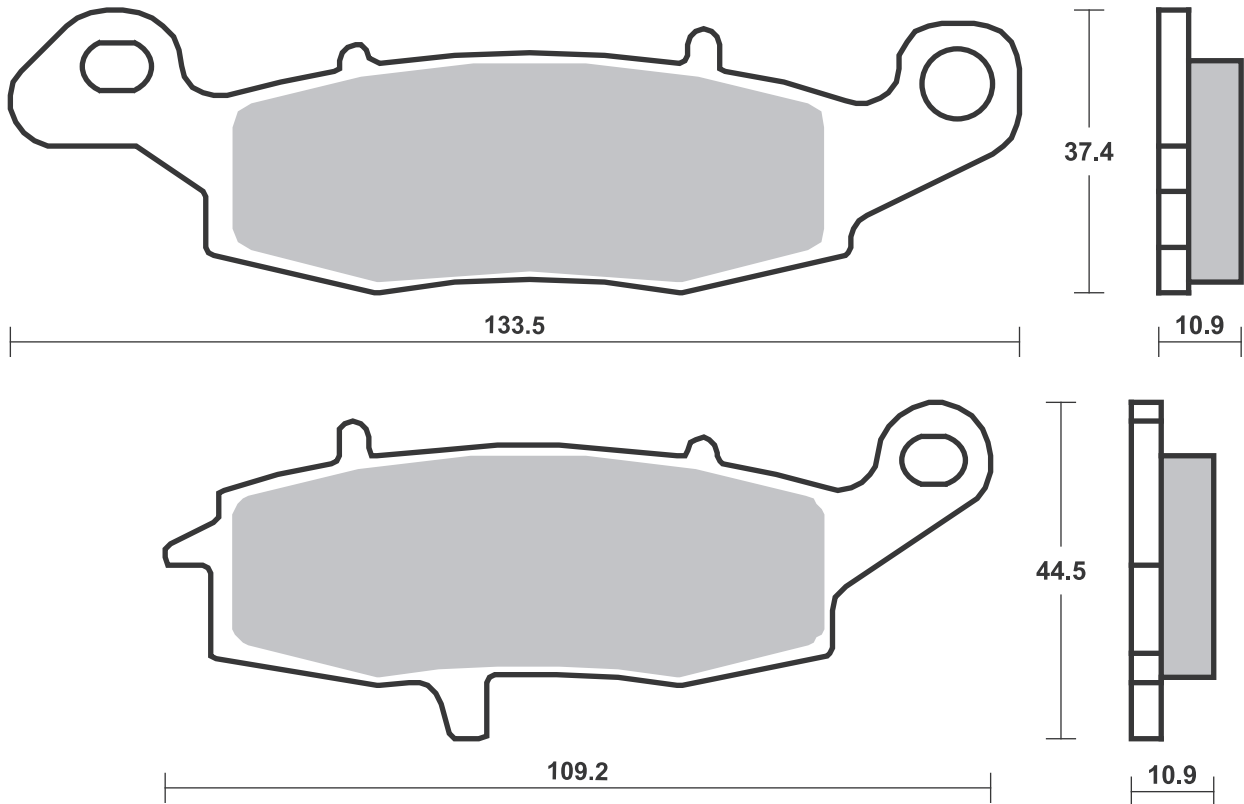

Brake Pad 1:1 Drawings,  
Compounds, Fitments



Available compounds

LS • DC • DS-1 • DS-2 • RQ

SBS 887

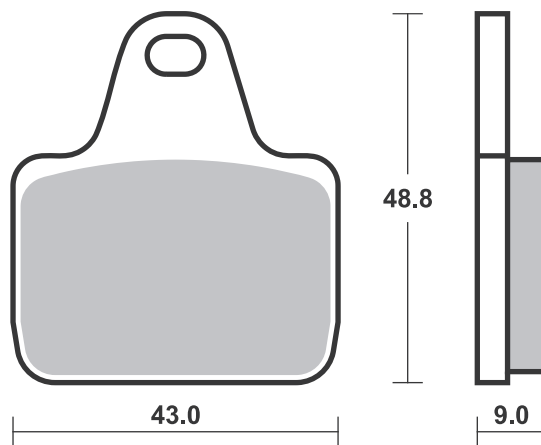

Available compounds

DS-1 • DS-2

SBS 889

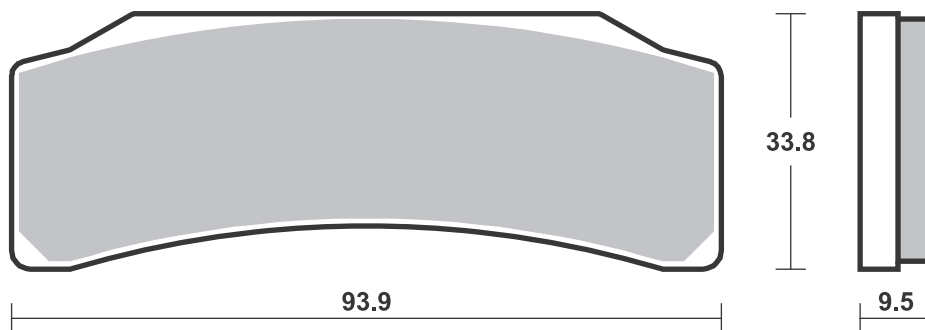

Available compounds

LS

SBS 892

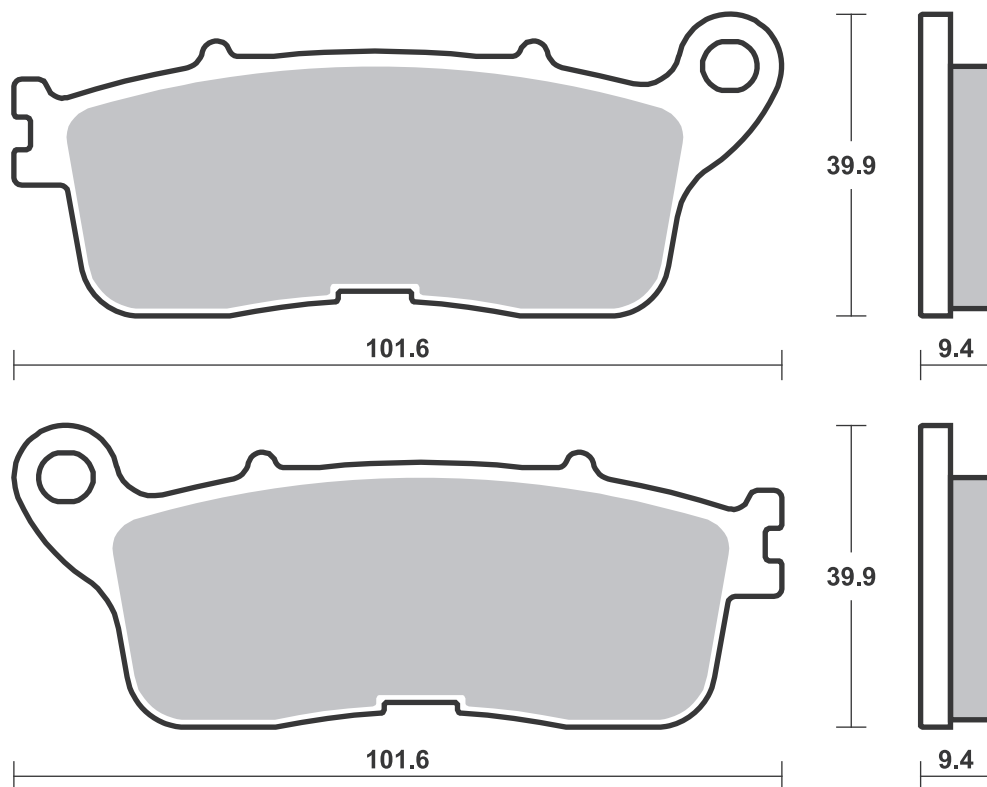



Available compounds

HF • HS

SBS 893

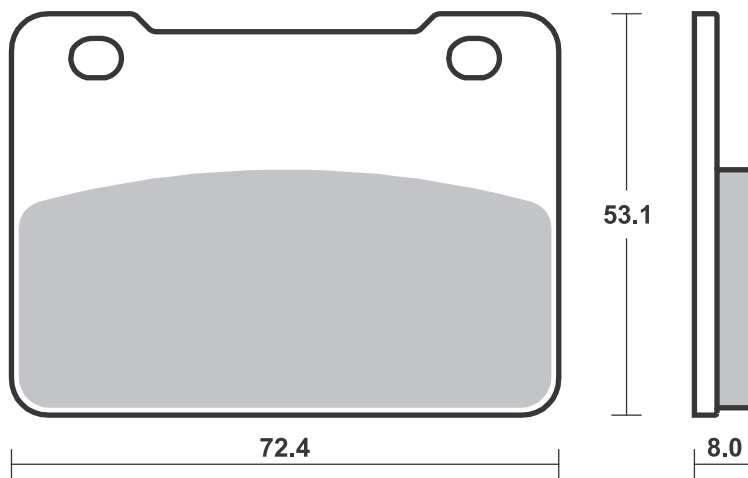

Available compounds

HS • SP • DC • RST

SBS 894

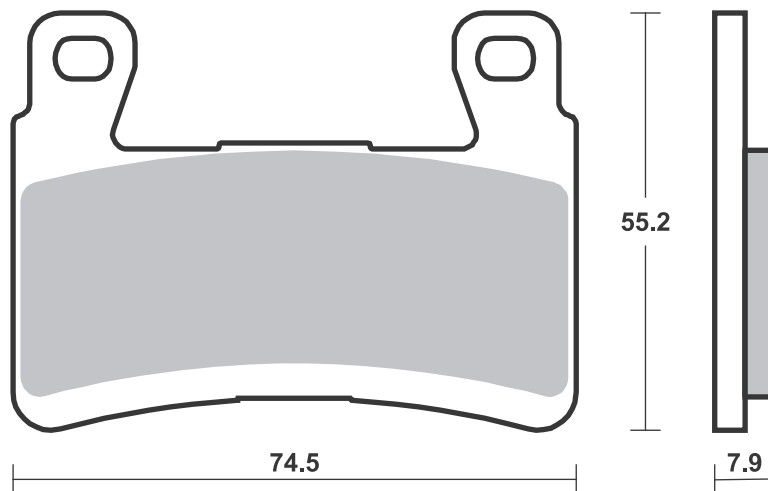

Available compounds

HF • RSI

SBS 895

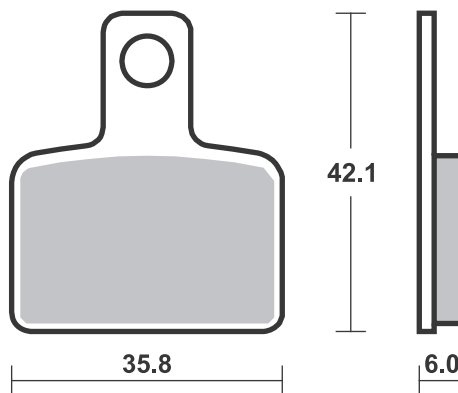





Available compounds

HF • RSI

SBS 896

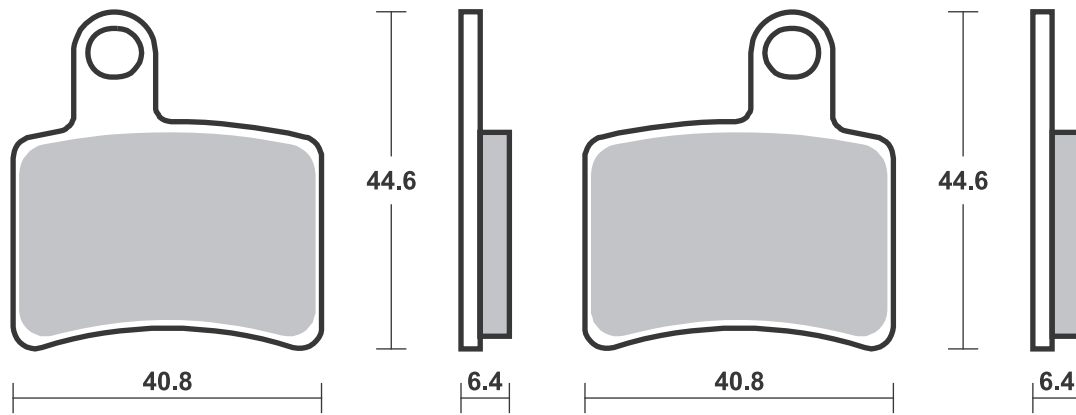

Available compounds

SI • RSI • ATS • PSI

SBS 897

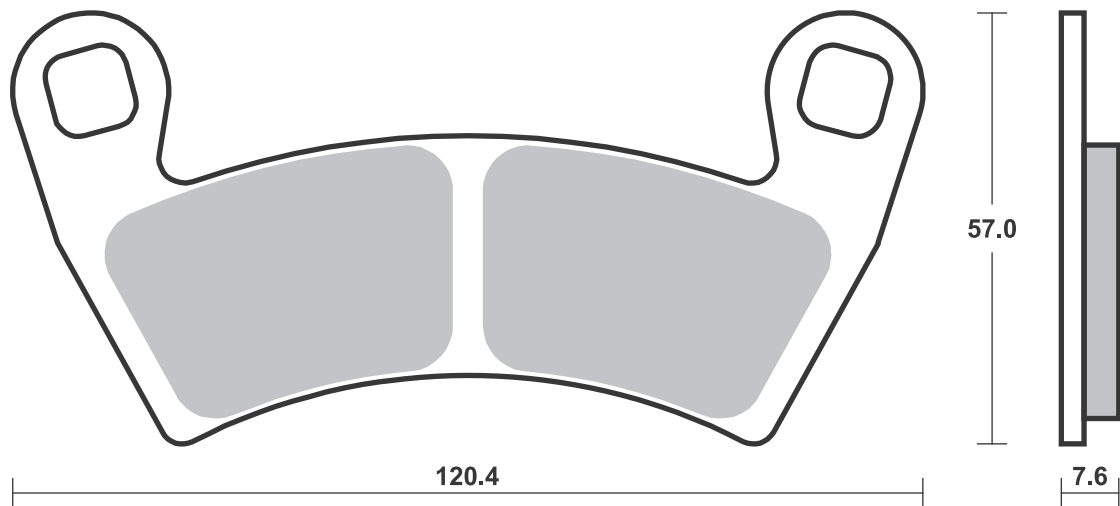

Available compounds

SI • RSI • ATS • PSI

SBS 898

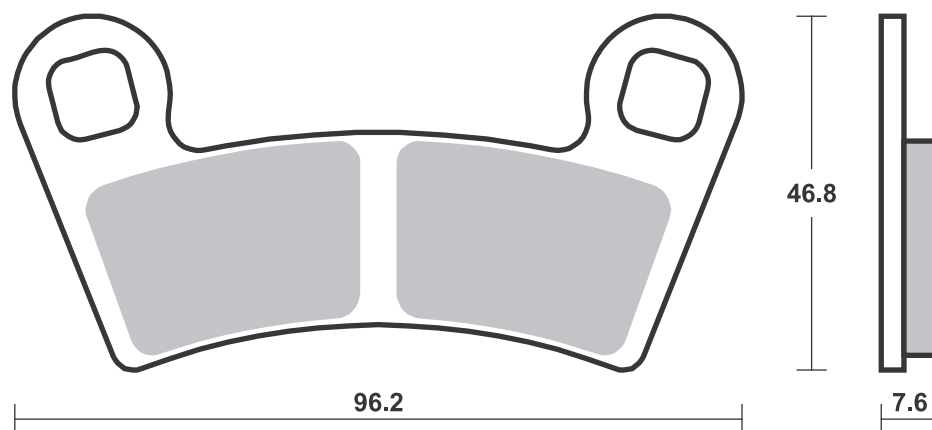



POLARIS			
500 Sportsman HO			
(from			
16.12.2008)	09-14	ATS	ATS
550 Sportsman	11-14	ATS	ATS
550 Sportsman			
EPS	10-14	ATS	ATS
550 Sportsman			
EPS X2	14-14	ATS	ATS
550 Sportsman			
Touring EPS	10-12	ATS	ATS
550 Sportsman X2	10-14	ATS	ATS
550 Sportsman XP	09-12	ATS	ATS
550 Sportsman XP			
EPS	09-14	ATS	ATS
550 Sportsman XP			
Touring EPS	12-14	ATS	ATS
800 Sportsman			
(from			
16.12.2008)	09-14	ATS	ATS
850 Forest	15-15	ATS	ATS
850 Scrambler	15-15	ATS	ATS
850 Scrambler			
HO EPS	13-15	ATS	ATS



POLARIS			
850 Scrambler MD	15-15	ATS	ATS
850 Scrambler XP			
HO EPS	14-15	ATS	ATS
850 Sportsman	11-13	ATS	ATS
850 Sportsman			
MV	12-12	ATS	ATS
850 Sportsman			
Touring	14-15	ATS	ATS
850 Sportsman			
Touring EPS	10-13	ATS	ATS
850 Sportsman			
Touring HO			
EPS	13-14	ATS	ATS
850 Sportsman			
Touring MD	15-15	ATS	ATS
850 Sportsman X2	11-11	ATS	ATS
850 Sportsman XP	09-14	ATS	ATS
850 Sportsman XP			
EPS	09-14	ATS	ATS
850 Sportsman XP			
HO EPS	13-14	ATS	ATS
850 Sportsman XP			
HO EPS MD	15-15	ATS	ATS



POLARIS			
850 Sportsman XP			
Touring EPS	15-15	ATS	ATS
1000 Forest	15-15	ATS	ATS
1000 Scrambler MD	15-18	ATS	ATS
1000 Scrambler XP	15-18	ATS	ATS
1000 Scrambler XP			
HO EPS	14-14	ATS	ATS
1000 Sportsman MD	15-18	ATS	ATS
1000 Sportsman			
Touring	15-18	ATS	ATS
1000 Sportsman XP	15-18	ATS	ATS

## SBS 900 Recommended compound



APRILIA			
660 Tuono Factory	22-22	SP	
RS 660	20-22	SP	
RS 660 Trofeo	22-22	SP	
RSV 1000 Tuono V4 R	14-14	HS	
RSV 1100 Tuono V4	15-15	HS	
RSV 1100 Tuono V4			
Factory	15-16	HS	
RSV 1100 Tuono V4 RR	15-16	HS	
1200 Caponord	13-19	SP	
1200 Caponord Rally	15-19	SP	
1200 Caponord			
Travel Pack	16-19	SP	
BENELLI			
752 S	20-20	HS	
800 Leoncino	20-20	HS	
BMW			
F 800 R	15-18	HS	
F 900 R	20-22	SP	
F 900 XR	20-22	SP	
S 1000 XR	15-19	SP	
R 1200 GS	13-18	SP	
R 1200 GS Adventure	14-16	SP	
R 1200 Nine-T	14-22	HS	
R 1200 R	15-18	HS	
R 1200 RS	14-18	HS	
R 1200 RT	14-18	HS	
R 1250 R	19-22	HS	
R 1250 RS	19-22	HS	
CAN-AM			
1330 Spyder F3	15-19	HS	
1330 Spyder F3			
Limited	16-19	HS	
1330 Spyder F3-S	15-19	HS	



CAN-AM			
1330 Spyder F3-T	16-19	HS	
1330 Spyder RS	14-16	HS	
1330 Spyder RS			
RSS	13-13	HS	
1330 Spyder RSS	14-15	HS	
1330 Spyder RSS			
Special Series	15-15	HS	
1330 Spyder RT	14-18	HS	
1330 Spyder RT			
Limited	13-19	HS	
1330 Spyder RT			
RTS	13-13	HS	
1330 Spyder RTS	14-15	HS	
1330 Spyder RTS			
Special Series	15-15	HS	
1330 Spyder ST	14-16	HS	
1330 Spyder ST			
Limited	13-15	HS	
1330 Spyder ST STS	13-13	HS	
1330 Spyder STS	14-15	HS	
1330 Spyder STS			
Special Series	15-15	HS	
DUCATI			
797 Monster	17-21	HS	
797 Monster+	17-20	HS	
803 Scrambler	17-18	HS	
803 Scrambler			
Classic	15-19	HS	
803 Scrambler CR	17-20	HS	
803 Scrambler CR			
Cafe Racer	17-20	HS	
803 Scrambler DS			
Desert Sled	17-22	HS	
803 Scrambler			
Enduro	15-16	HS	



DUCATI			
803 Scrambler Flat			
Track Pro	16-16	HS	
803 Scrambler Full			
Throttle	15-20	HS	
803 Scrambler			
Icon	15-22	HS	
803 Scrambler			
Icon Dark	20-22	HS	
803 Scrambler			
Mach 2.0	18-18	HS	
803 Scrambler			
SCR	20-20	HS	
803 Scrambler			
Street Classic	17-18	HS	
803 Scrambler			
Urban Enduro	15-18	HS	
803 Scrambler			
Urban Motard	22-22	SP	
821 Hypermotard	13-16	HS	
821 Hypermotard			
ABS	13-16	HS	
821 Hypermotard			
SP	13-16	HS	
821 Hypermotard			
SP ABS	13-16	HS	
821 Hyperstrada	13-16	HS	
821 Hyperstrada			
ABS	13-16	HS	
821 Monster	14-21	HS	
821 Monster Dark	15-16	HS	
821 Monster			
Stealth	19-21	HS	
899 Panigale	14-15	HS	
937 Monster	20-22	SP	
937 Monster +	20-22	SP	
939 Hypermotard	16-18	HS	

Available compounds

SI • RSI • ATS

SBS 899

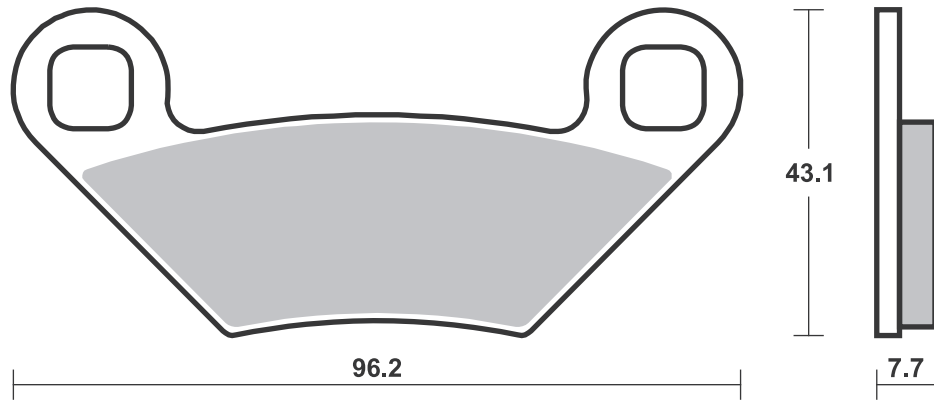

Available compounds

HS • SP • DC • RST • DS-1 • DS-2 • H.HS

SBS 900

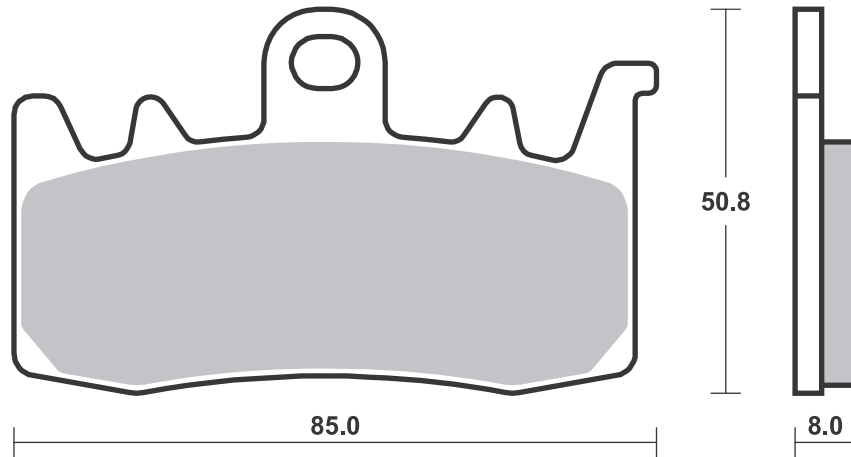

**SBS 900** Recommended compound

<b>DUCATI</b>		
939 Hypermotard		
SP	16-18	<b>HS</b>
939 Hyperstrada	16-16	<b>HS</b>
939 SuperSport	17-20	<b>HS</b>
939 SuperSport		
S	17-20	<b>HS</b>
950 Hypermotard	19-22	<b>HS</b>
950 Hypermotard		
SP	19-22	<b>HS</b>
950 Multistrada	17-22	<b>HS</b>
950 Multistrada S	19-22	<b>HS</b>
950 Supersport	20-22	<b>HS</b>
950 Supersport S	20-22	<b>HS</b>
955 Panigale V2	20-22	<b>SP</b>
955 Panigale V2		
Bayliss	22-22	<b>SP</b>
955 Streetfighter		
V2	22-22	<b>SP</b>
959 Panigale	16-20	<b>HS</b>
959 Panigale		
Corse	18-20	<b>HS</b>
1100 Scrambler	18-19	<b>HS</b>
1100 Scrambler		
Dark Pro	20-22	<b>HS</b>
1100 Scrambler		
Desert X	20-20	<b>SP</b>
1100 Scrambler		
Pro	20-22	<b>HS</b>
1100 Scrambler		
Special	18-19	<b>HS</b>
1100 Scrambler		
Sport	18-19	<b>HS</b>
1100 Scrambler		
Sport Pro	20-22	<b>HS</b>
1100 Scrambler		
Tribute Pro	22-22	<b>SP</b>
1158 Multistrada		
V4	21-21	<b>SP</b>



<b>DUCATI</b>		
1200 Monster	14-21	<b>HS</b>
1200 Multistrada	15-16	<b>SP</b>
1200 Multistrada		
Enduro	16-18	<b>SP</b>
1200 Multistrada		
Enduro Pro	18-18	<b>SP</b>
1260 Diavel	19-22	<b>SP</b>
1260 Multistrada		
Enduro	19-21	<b>SP</b>
<b>FANTIC</b>		
500 Caballero	17-17	<b>HS</b>
<b>HARLEY DAVIDSON</b>		
Livewire	19-21	<b>H.HS</b>
975 Bronx	20-21	<b>H.HS</b>
1250 Pan America	21-22	<b>SP</b>
<b>INDIAN</b>		
FTR 1200	19-20	<b>H.HS</b>
FTR 1200 S	19-20	<b>H.HS</b>
1800 Challenger	20-20	<b>H.HS</b>
1800 Challenger		
Dark Horse	20-20	<b>H.HS</b>
1800 Challenger		
Limited	20-20	<b>H.HS</b>
<b>KAWASAKI</b>		
Z 1000 H2	20-21	<b>SP</b>
<b>KYMCO</b>		
AK 550 ST	22-22	<b>HS</b>
<b>MOTO-GUZZI</b>		
V100 1042 Mandello	22-22	<b>SP</b>
<b>MV AGUSTA</b>		
800 Rivale	13-17	<b>HS</b>



<b>MV AGUSTA</b>		
800 Stradale	15-16	<b>HS</b>
800 Turismo		
Veloce	14-19	<b>HS</b>
800 Turismo		
Veloce		
Lusso	14-20	<b>HS</b>
800 Turismo		
Veloce RC	17-20	<b>HS</b>
<b>NORTON</b>		
961 Commando		
Cafe Racer		
MKII	18-19	<b>HS</b>
961 Commando		
Sport	18-19	<b>HS</b>
961 Dominator		
Naked	17-19	<b>HS</b>
<b>SWM</b>		
400 Varez	20-20	<b>HS</b>
<b>TRIUMPH</b>		
765 Street		
Triple R	17-20	<b>HS</b>
765 Street		
Triple R Low	17-18	<b>HS</b>
1200 Tiger		
Explorer	16-17	<b>SP</b>
1200 Tiger XCA	18-20	<b>SP</b>
1200 Tiger XCX	18-20	<b>SP</b>
1200 Tiger XR	18-19	<b>SP</b>
1200 Tiger XRT	18-20	<b>SP</b>
1200 Tiger XRX	18-20	<b>SP</b>
1200 Tiger XRX		
Low	18-20	<b>SP</b>
2500 Rocket III GT	19-22	<b>SP</b>
2500 Rocket III R	19-22	<b>SP</b>

**SBS 901** Recommended compound

<b>APRILIA</b>		
RSV4-RF 1000	15-20	<b>SP</b>
RSV4-RR 1000	15-20	<b>SP</b>
RSV 1100 Tuono V4		
Factory	17-18	<b>HS</b>
RSV 1100 Tuono V4		
RR	17-19	<b>HS</b>
<b>BIMOTA</b>		
BB3 1000	14-18	<b>SP</b>
DB7 1099	09-09	<b>HS</b>
DB8 1198	10-14	<b>SP</b>
DB11 1200 VLX	13-13	<b>HS</b>
<b>BMW</b>		
S 1000 RR HP4	12-14	<b>SP</b>
1200 HP2 Sport	08-10	<b>SP</b>
<b>BREMBO RACING CALIPERS</b>		
100 mm Radial GP4		
RX 220B01020 P4 32		
(disc min. Th. 4.0 mm)		



<b>BREMBO RACING CALIPERS</b>		
108 mm Radial GP4		
RX 220B01020 P4 32		
(disc min. Th. 4.0 mm)		
130 mm Radial GP4		
RX 220B01020 P4 32		
(disc min. Th. 4.0 mm)		
<b>DUCATI</b>		
1200 Diavel	11-18	<b>HS</b>
1200 Diavel Strada	11-14	<b>HS</b>
1200 Xdiavel	16-18	<b>HS</b>
1200 Xdiavel S	16-18	<b>HS</b>
1260 Diavel S	19-22	<b>HS</b>
1260 Xdiavel	19-22	<b>SP</b>
1260 Xdiavel Dark	22-22	<b>SP</b>
1260 Xdiavel S	19-22	<b>SP</b>
<b>ENERGICA</b>		
Ego	15-21	<b>SP</b>
Eva EsseEsse9	18-21	<b>SP</b>
Eva Ribelle	15-21	<b>SP</b>



<b>HONDA</b>		
CBR 1000 RR SP	14-22	<b>SP</b>
CBR 1000 RR SP2	17-19	<b>SP</b>
CBR 1000 RR-R SP		
Fireblade	20-21	<b>SP</b>
RC213V-S 1000	16-18	<b>SP</b>
<b>KTM</b>		
890 Duke R	20-20	<b>SP</b>
1290 Super		
Duke GT	16-20	<b>SP</b>
<b>MOTO-MORINI</b>		
1200 Corsaro ZT	20-20	<b>SP</b>
1200 Corsaro ZZ	18-20	<b>HS</b>
1200 Milano	18-19	<b>HS</b>
1200 Scrambler	18-18	<b>HS</b>
1200 Super		
Scrambler	20-20	<b>SP</b>
<b>MV AGUSTA</b>		
F3 675	15-20	<b>HS</b>

Available compounds

HS • SP • DC • RST • DS-1 • DS-2 • H.HS

SBS 900

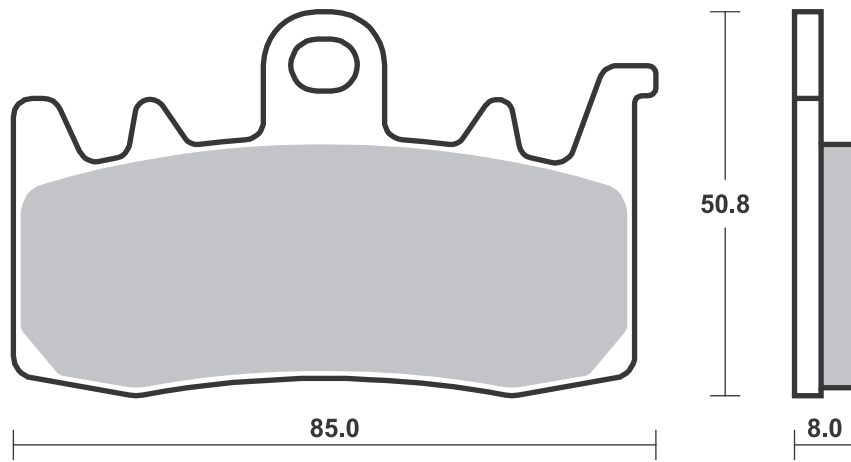

Available compounds

HS • SP • DC • RST • DS-1 • DS-2

SBS 901

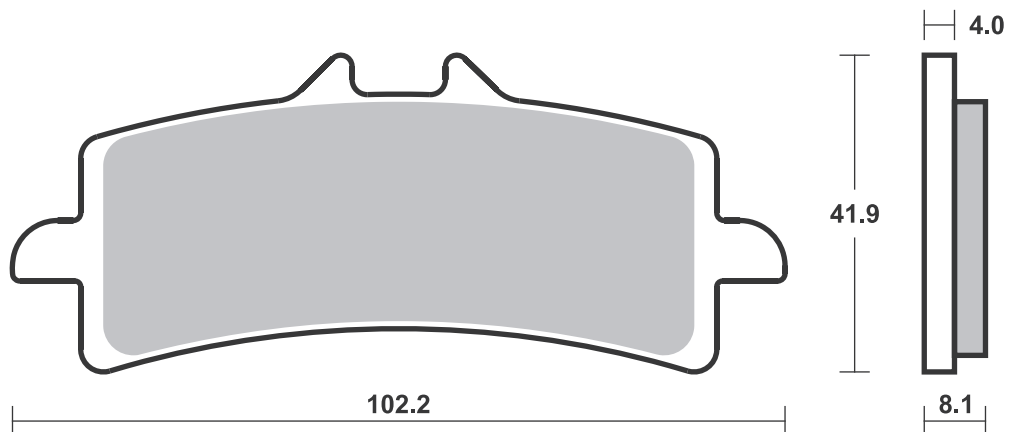



Available compounds

**HS • SP • DC • RST • DS-1 • DS-2**

**SBS 901**

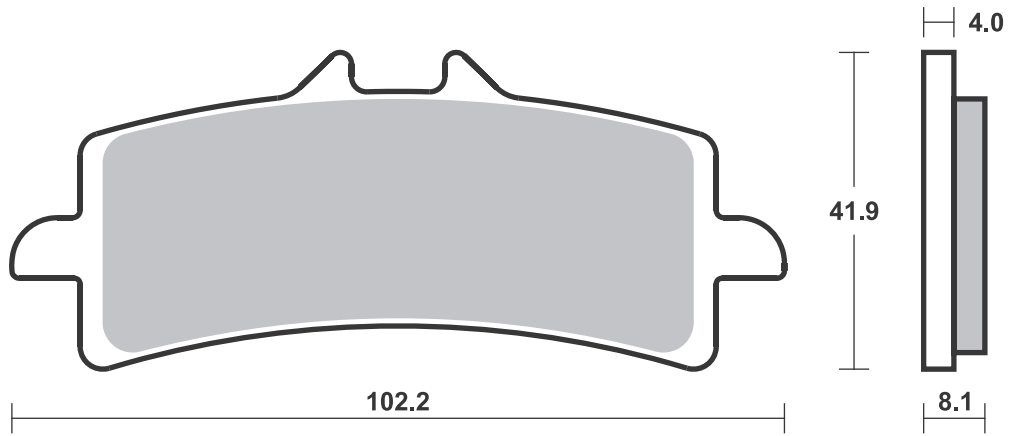

Available compounds

**H.LS**

**SBS 904**

1 set = 4 pcs.

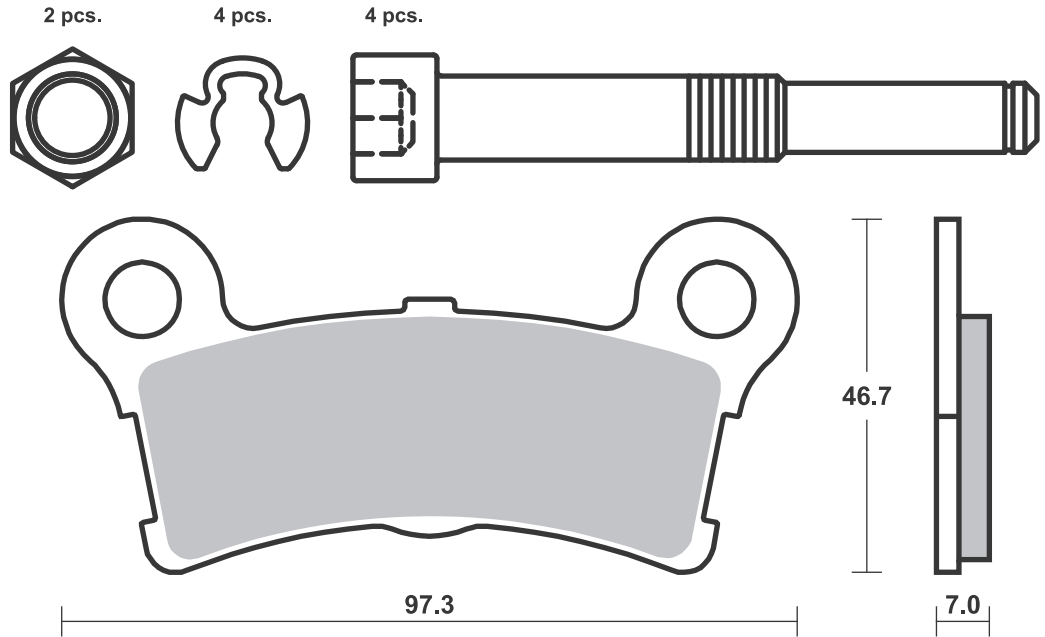





Available compounds

SI • RSI • ATS

SBS 905

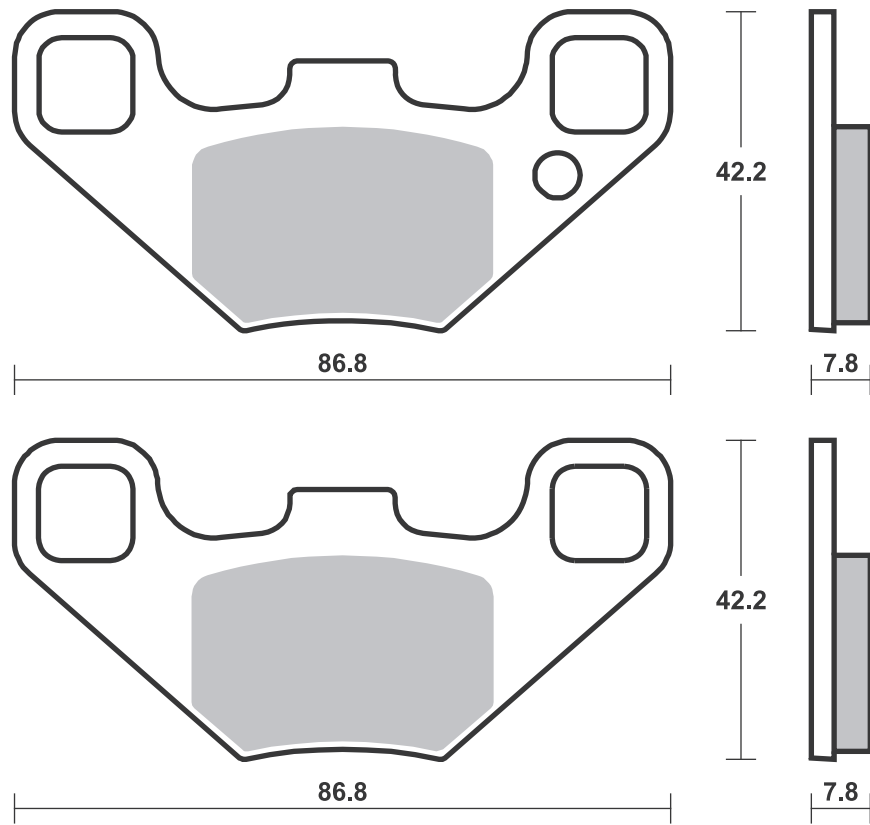

Available compounds

SI • RSI • ATS

SBS 906

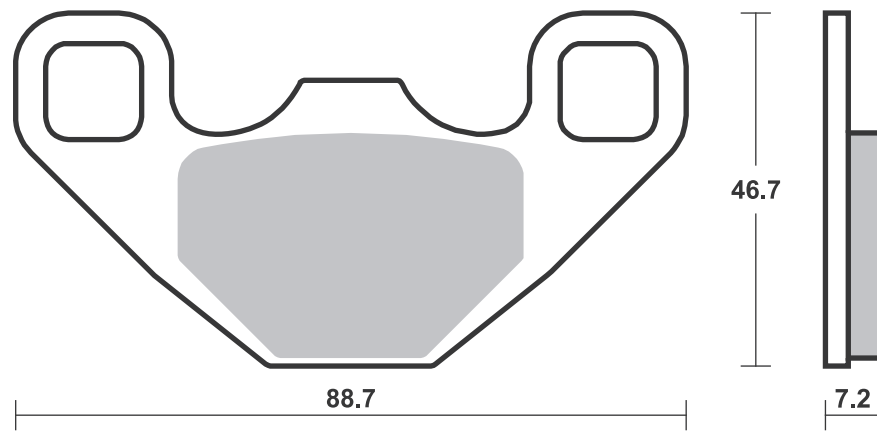



Available compounds

SI • RSI

SBS 907

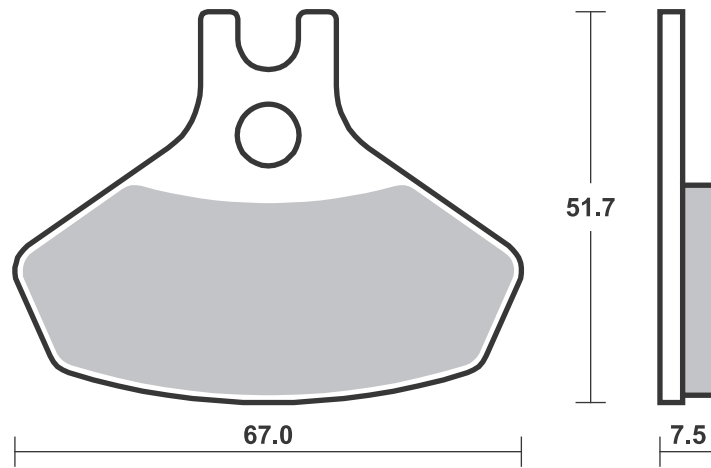

Available compounds

SI • RSI

SBS 908

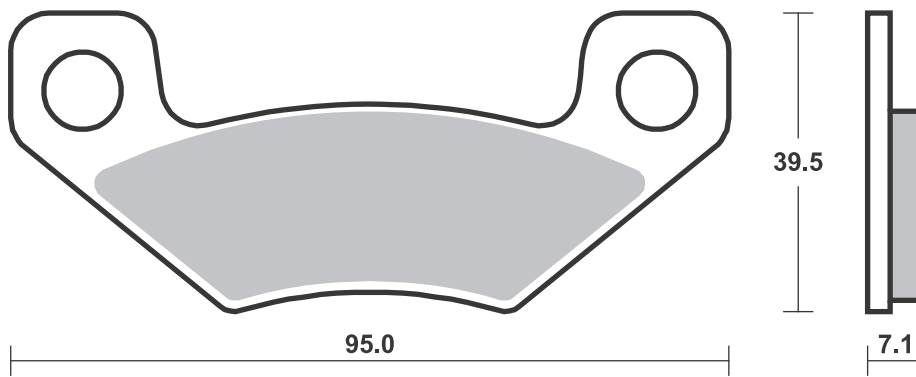



Available compounds

**DS-1 • DS-2**

**SBS 909**

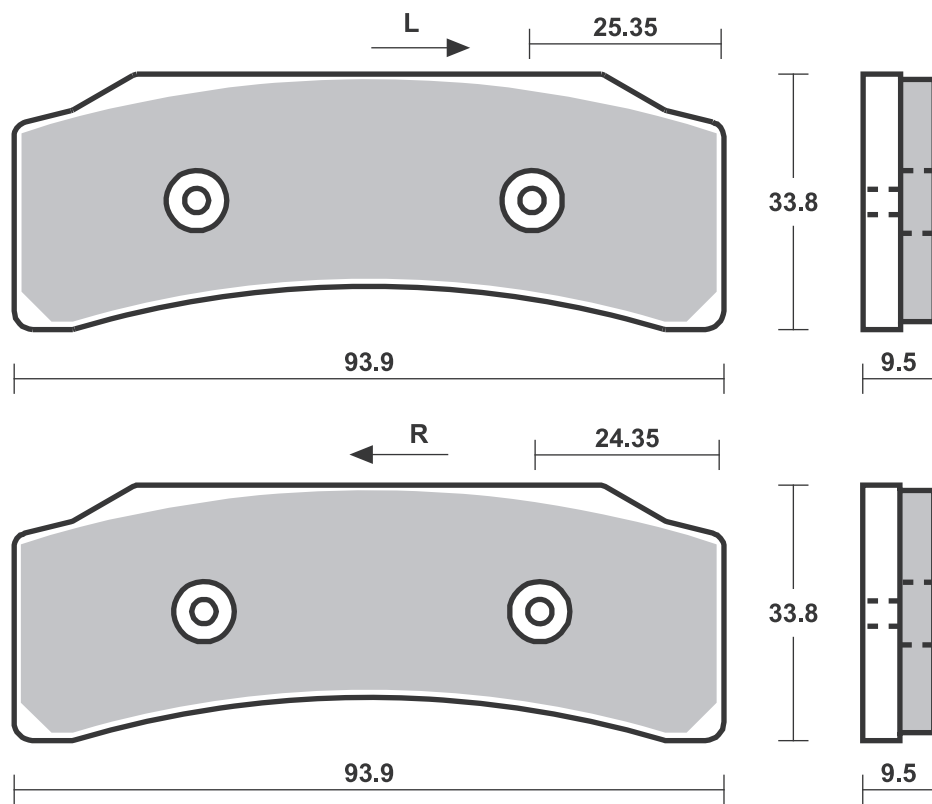

Available compounds

**SI • RSI**

**SBS 910**

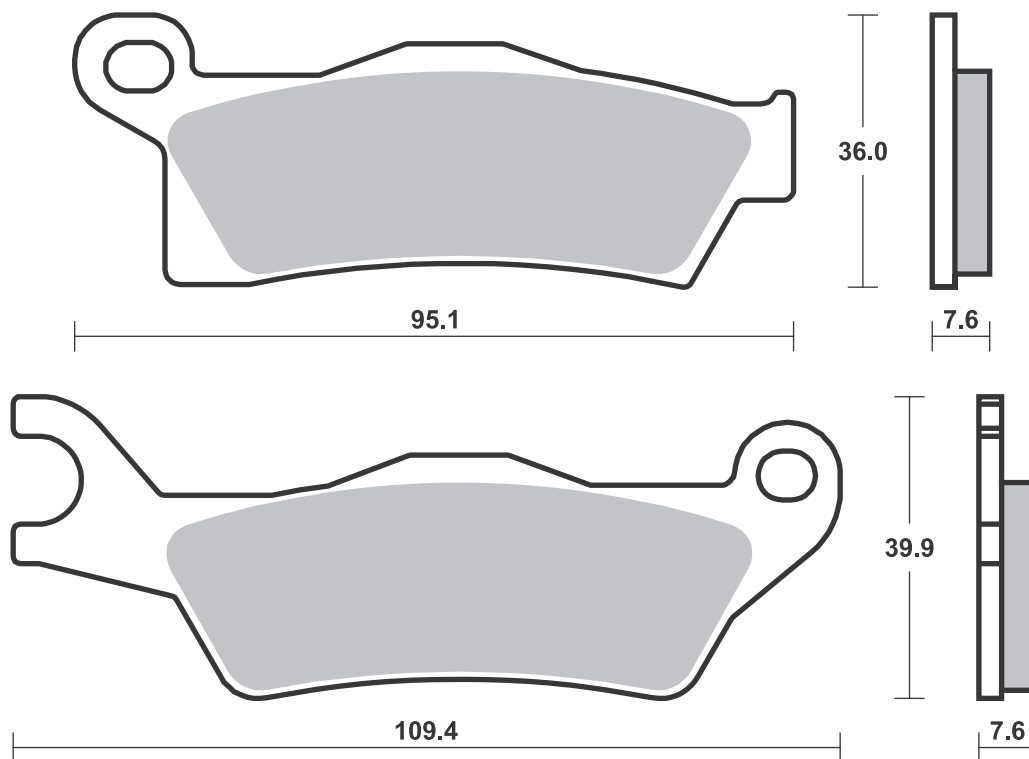



Available compounds

SI • RSI

SBS 911

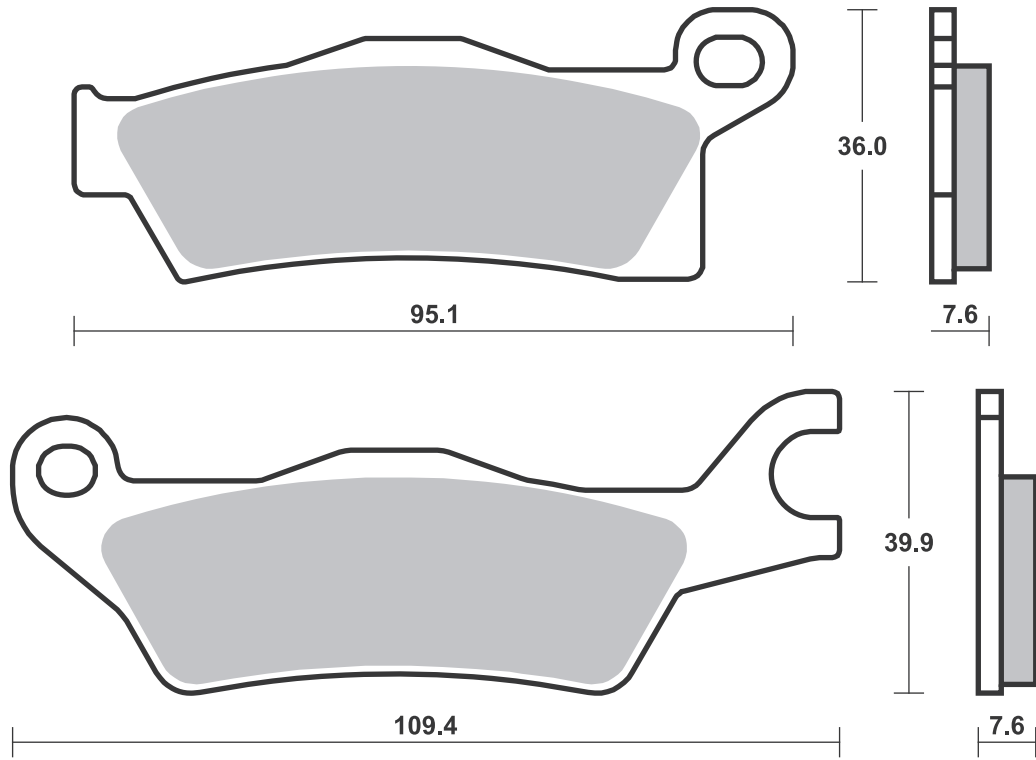

Available compounds

SI • RSI • ATS

SBS 912

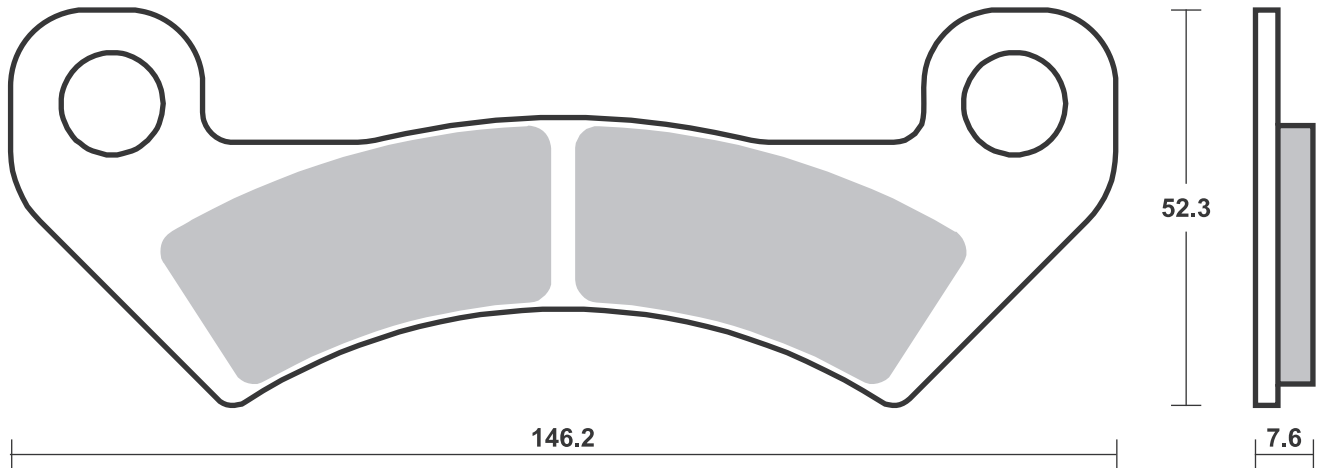

**SBS 914** Recommended compound**CF MOTO**

	450 C-Force L	16-17	<b>SI</b>
	450 G-Force L	16-17	<b>SI</b>
CF	500 Terralander	13-15	<b>SI</b>
	550 C-Force	16-17	<b>SI</b>
CF	625 Terralander	11-15	<b>SI</b>
CF	800 Terralander	12-14	<b>SI</b>

**GOES**

	360 Max	08-14	<b>SI</b>
	520 Max	07-12	<b>SI</b>
G	520	07-12	<b>SI</b>
G	525	12-14	<b>SI</b>
G	620	11-14	<b>SI</b>
G	625 A	12-14	<b>SI</b>

**SBS 915** Recommended compound**BENELLI**

TNT	125	18-19	<b>HF</b>
TNT	135	18-19	<b>HF</b>

**HONDA**

CB	125 R	18-20	<b>HF</b>
CBR	125 R	11-18	<b>HF</b>
MSX	125	14-21	<b>HF</b>
MSX	125 Grom	14-21	<b>HF</b>
CRF	250 L	13-15	<b>SI</b>
CRF	250 L ABS	17-21	<b>SI</b>
CRF	250 M	14-18	<b>SI</b>
CRF	250 Rally	17-19	<b>SI</b>
CB	300 R	18-21	<b>HF</b>
CB	300 R Neo Sports Cafe	19-19	<b>HF</b>
CRF	300 L	21-21	<b>SI</b>
CRF	300 Rally	21-21	<b>SI</b>

**SUZUKI**

GSX-R	125 RL	17-21	<b>HF</b>
GSX-R	125 RLX	17-21	<b>HF</b>
GSX-S	125 ML	17-19	<b>HF</b>
GSX-S	125 MLX	17-19	<b>HF</b>



Available compounds

SI • RSI

SBS 914

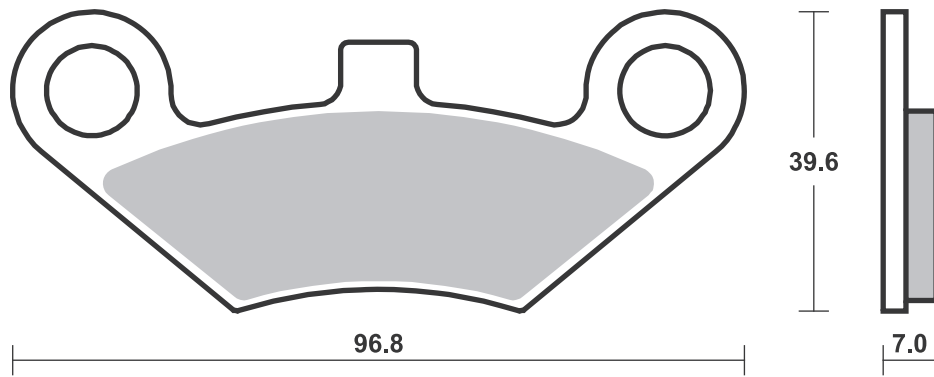

Available compounds

HF • SI • RSI

SBS 915

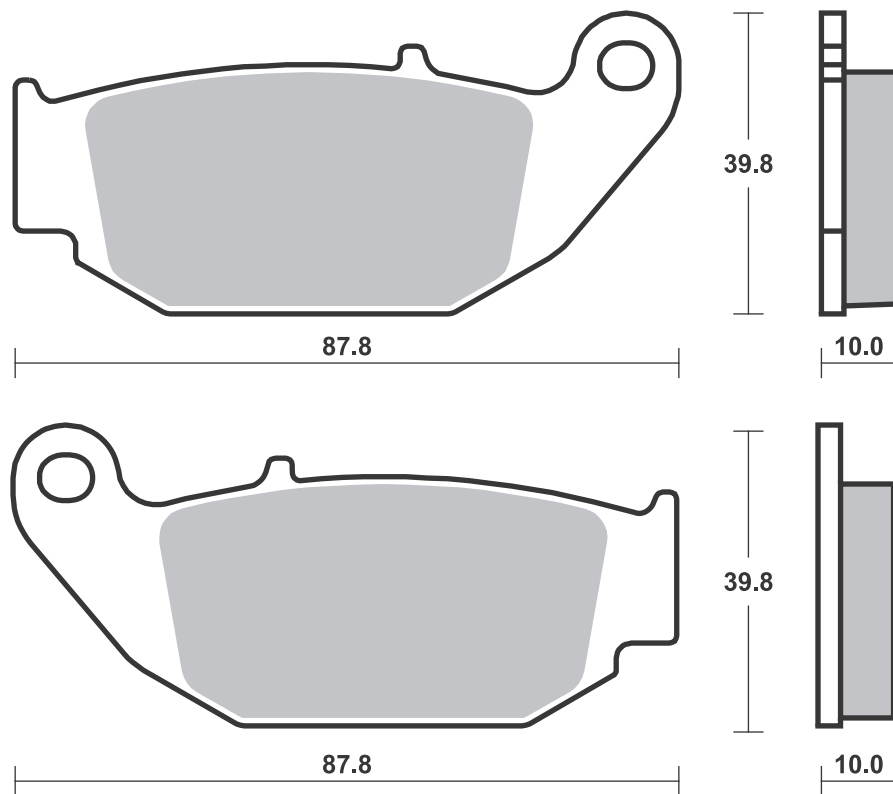



Available compounds

**HF • LS**

**SBS 920**

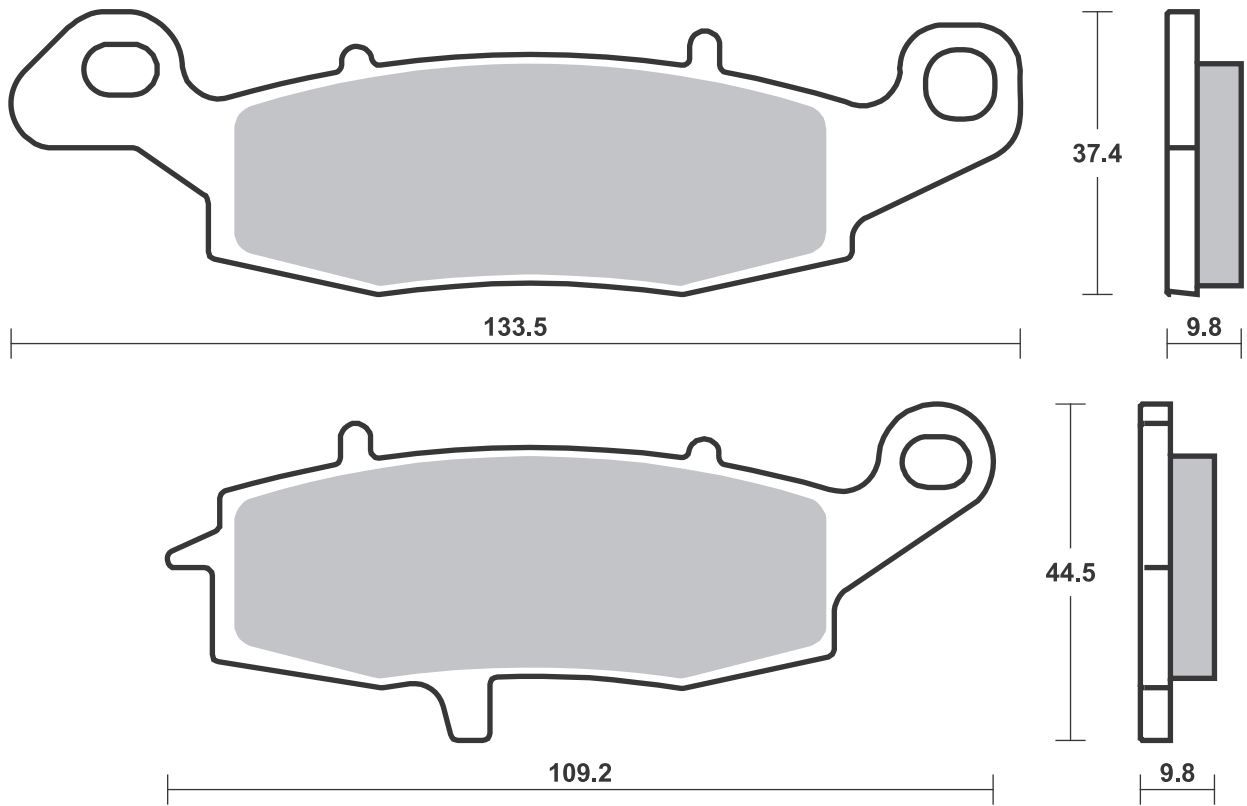

Available compounds

**HF**

**SBS 921**

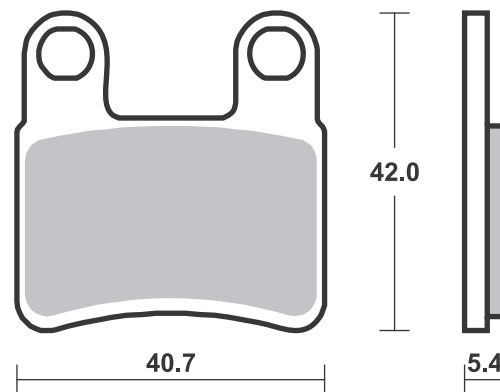



**HARLEY DAVIDSON**

FLHTCUTG 1690 Tri Glide	
Ultra	14- 16 <b>H.HS</b>
FLRT 1690 Freewheeler	
	15- 16 <b>H.HS</b>
FLHTCUTG 1750 Tri Glide	
Ultra	17- 19 <b>H.HS</b>
FLRT 1750 Freewheeler	
	17- 19 <b>H.HS</b>

Brake Pad 1:1 Drawings,  
Compounds, Fitments

Available compounds

**H.HS**

**SBS 922**

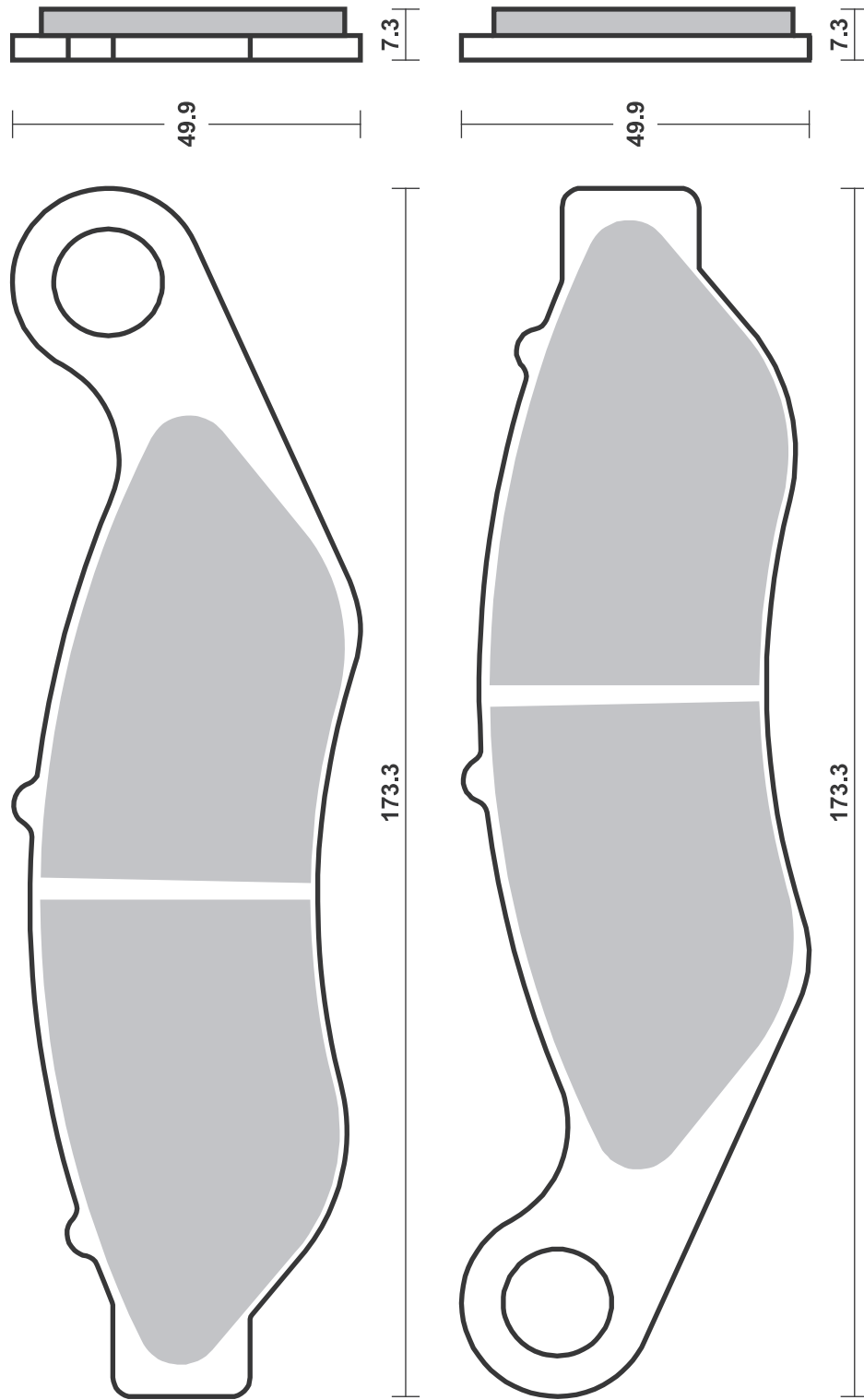



Available compounds

**H.LS**

**SBS 923**

1 set = 4 pcs.

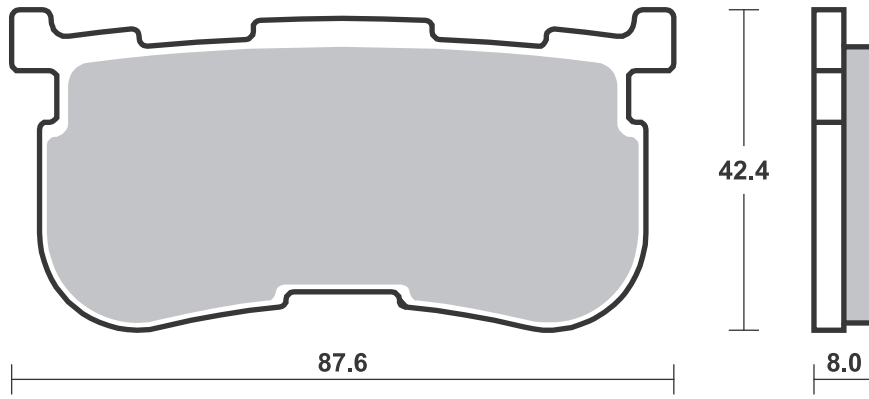

Available compounds

**H.HF • H.CT • H.HS • H.LS**

**SBS 924**

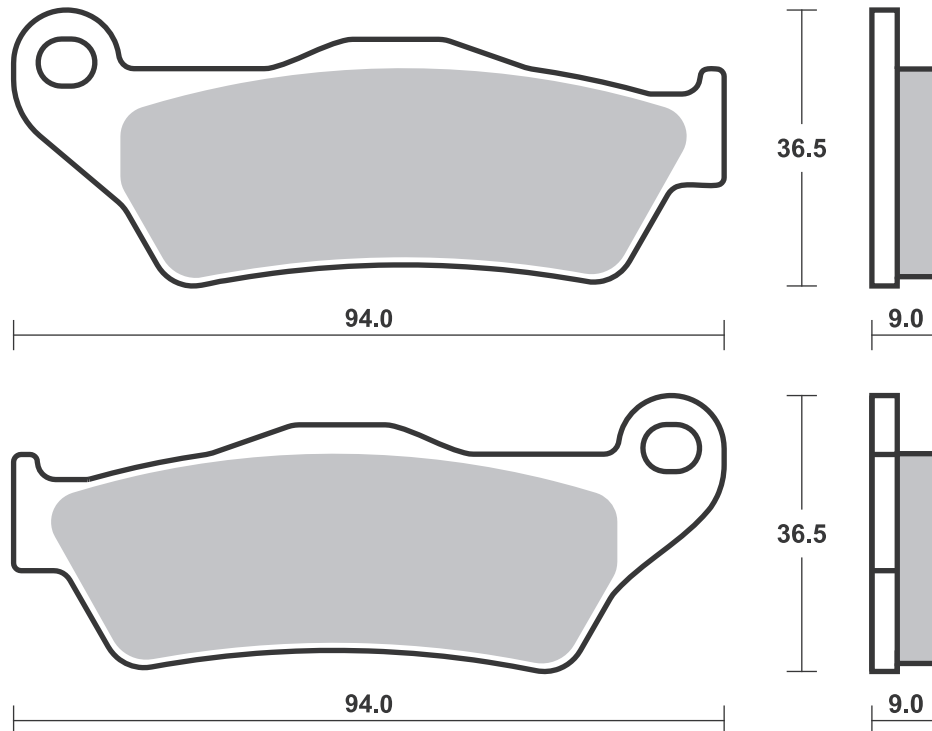





Available compounds

HF • RSI

SBS 925

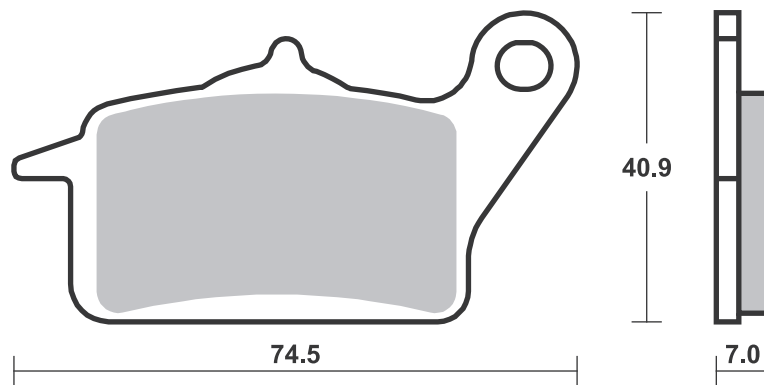
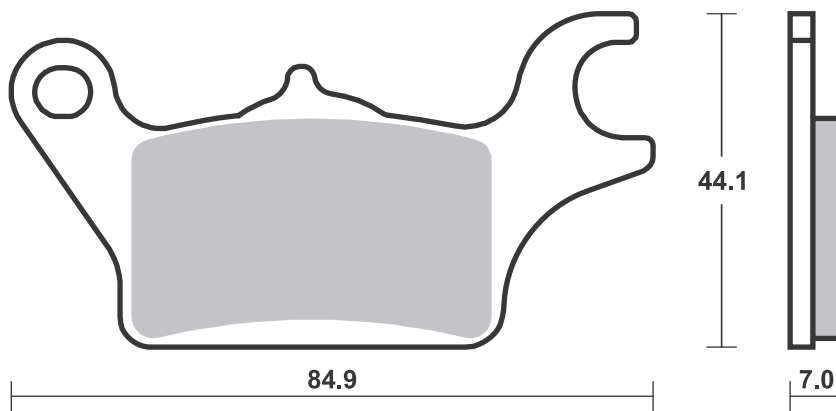

Available compounds

HF

SBS 926

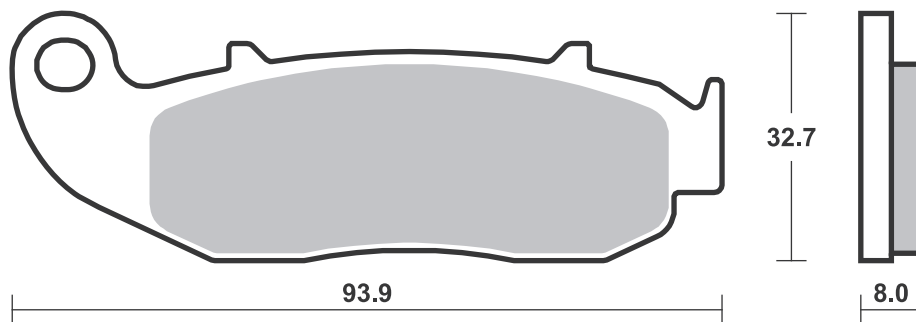
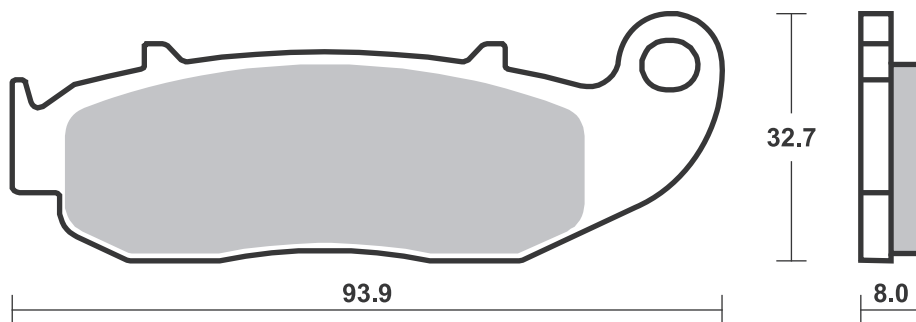



Available compounds

**H.HF • H.CT • H.HS**

**SBS 929**

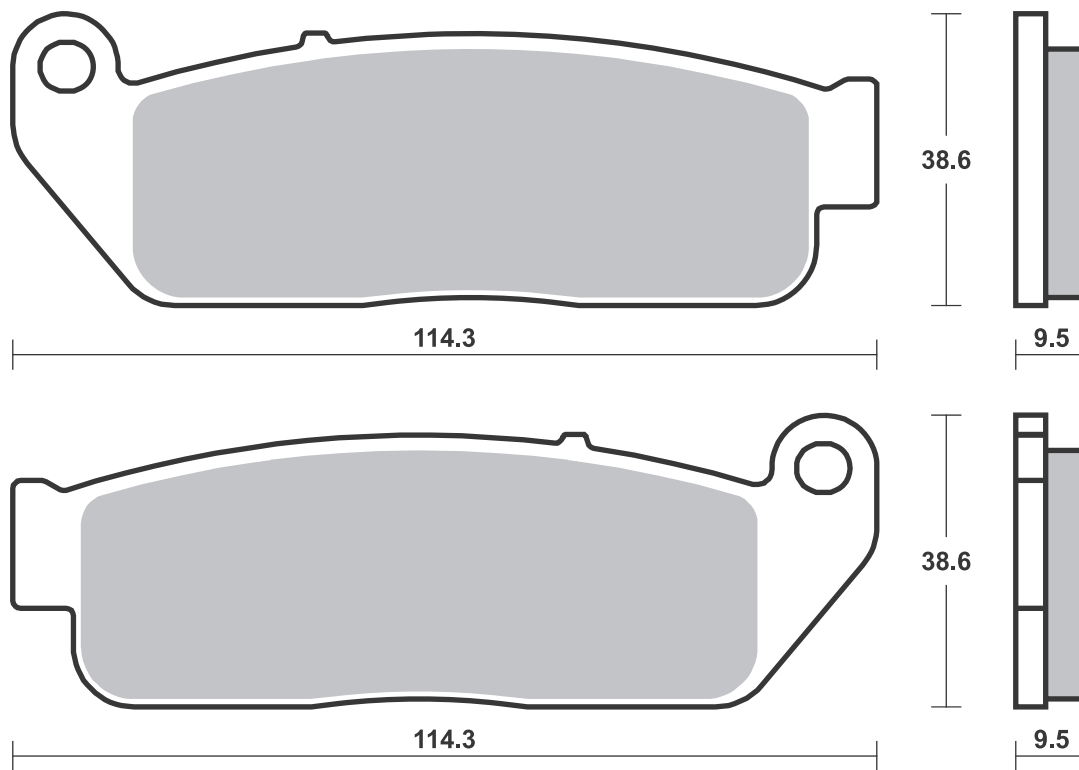

Available compounds

**H.HF • H.CT • H.LS**

**SBS 930**

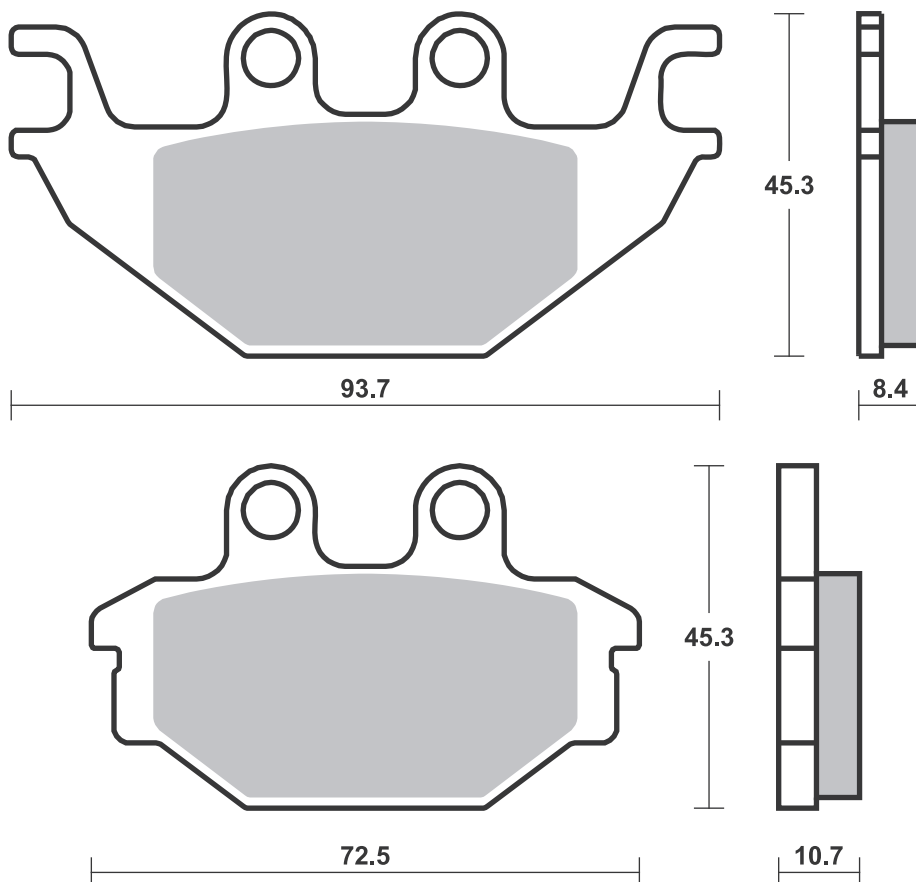



Available compounds

HF • HS • DC • RST • DS-1 • DS-2

SBS 931

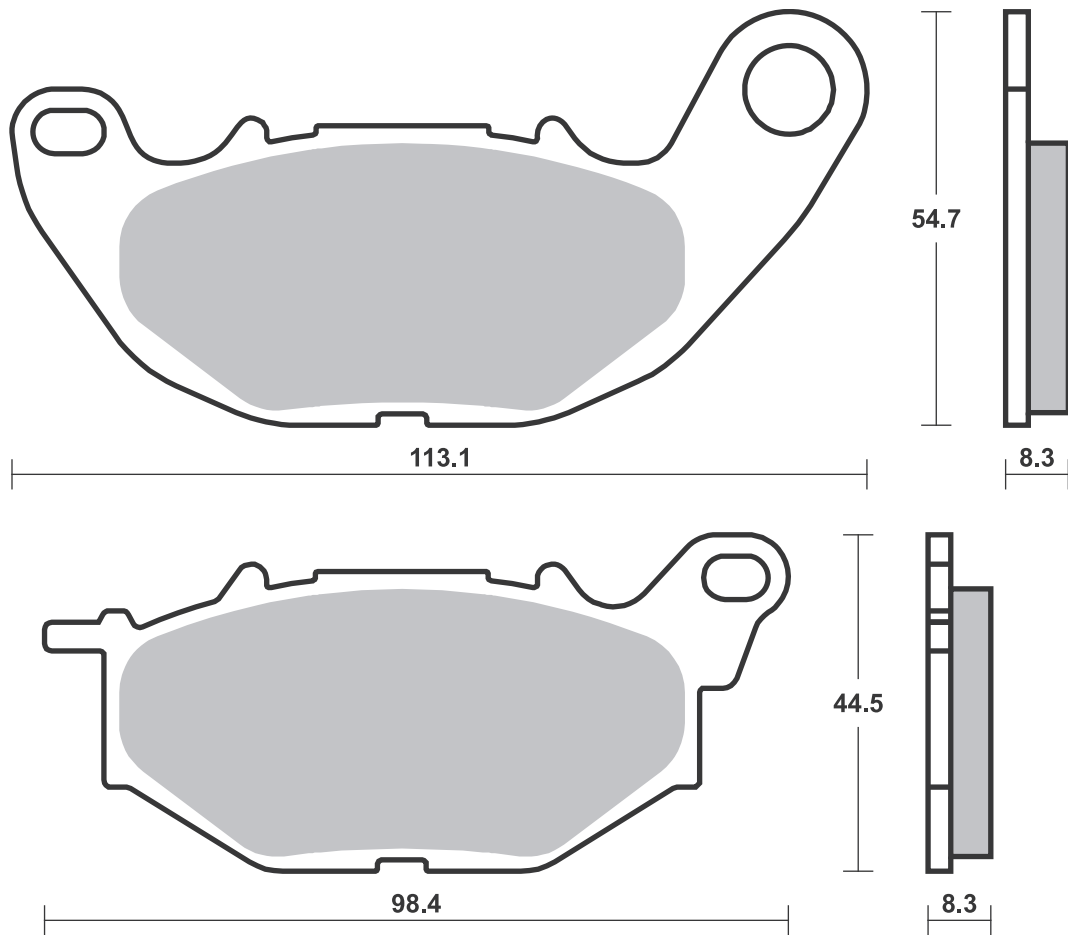



Available compounds

**HF • RQ**

**SBS 932**

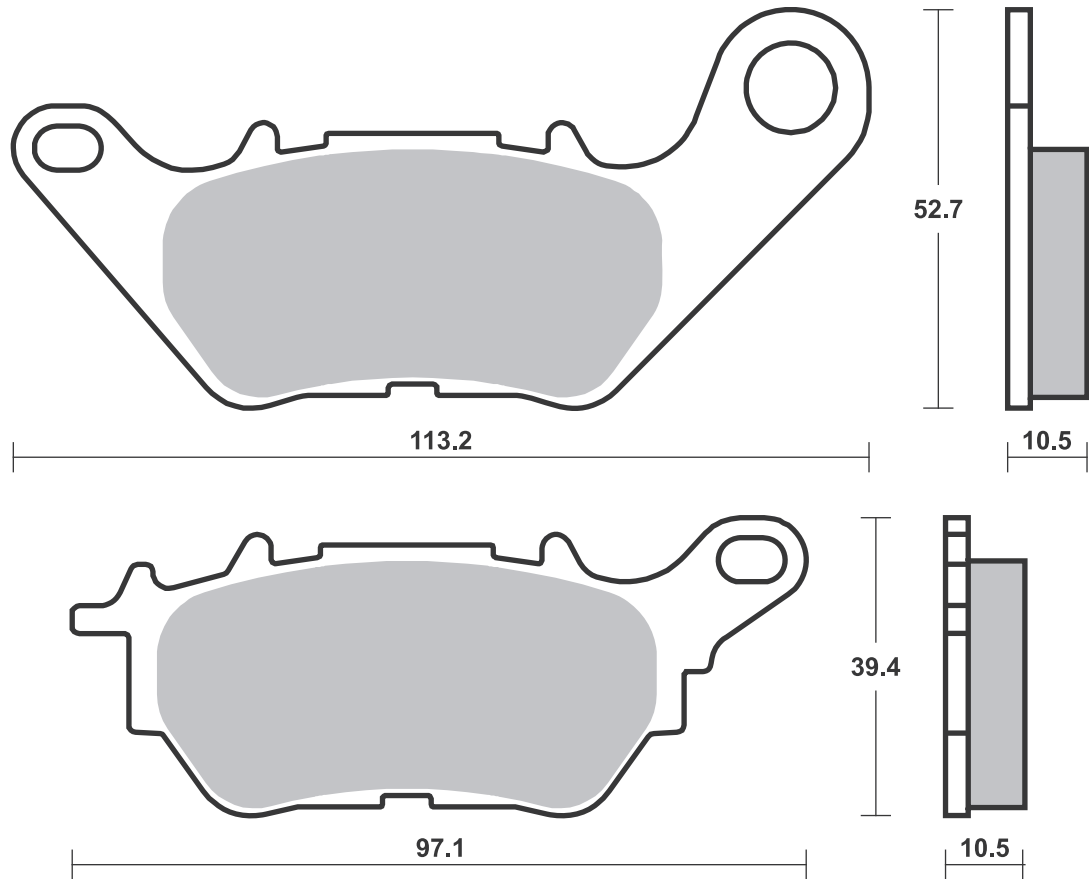

Available compounds

**HS**

**SBS 933**

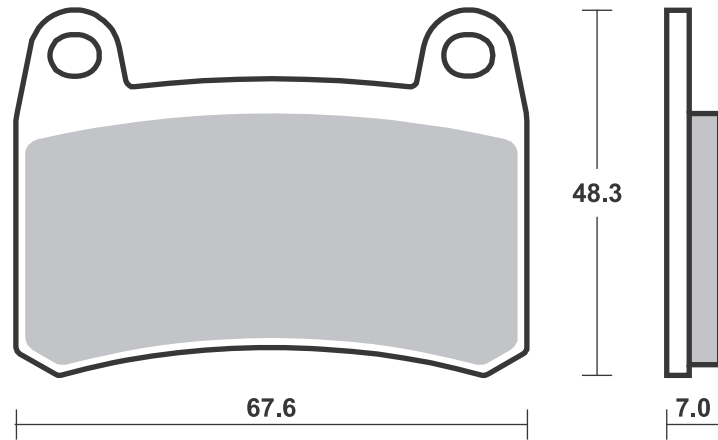





Available compounds

**H.HF • H.CT • H.HS**

**SBS 934**

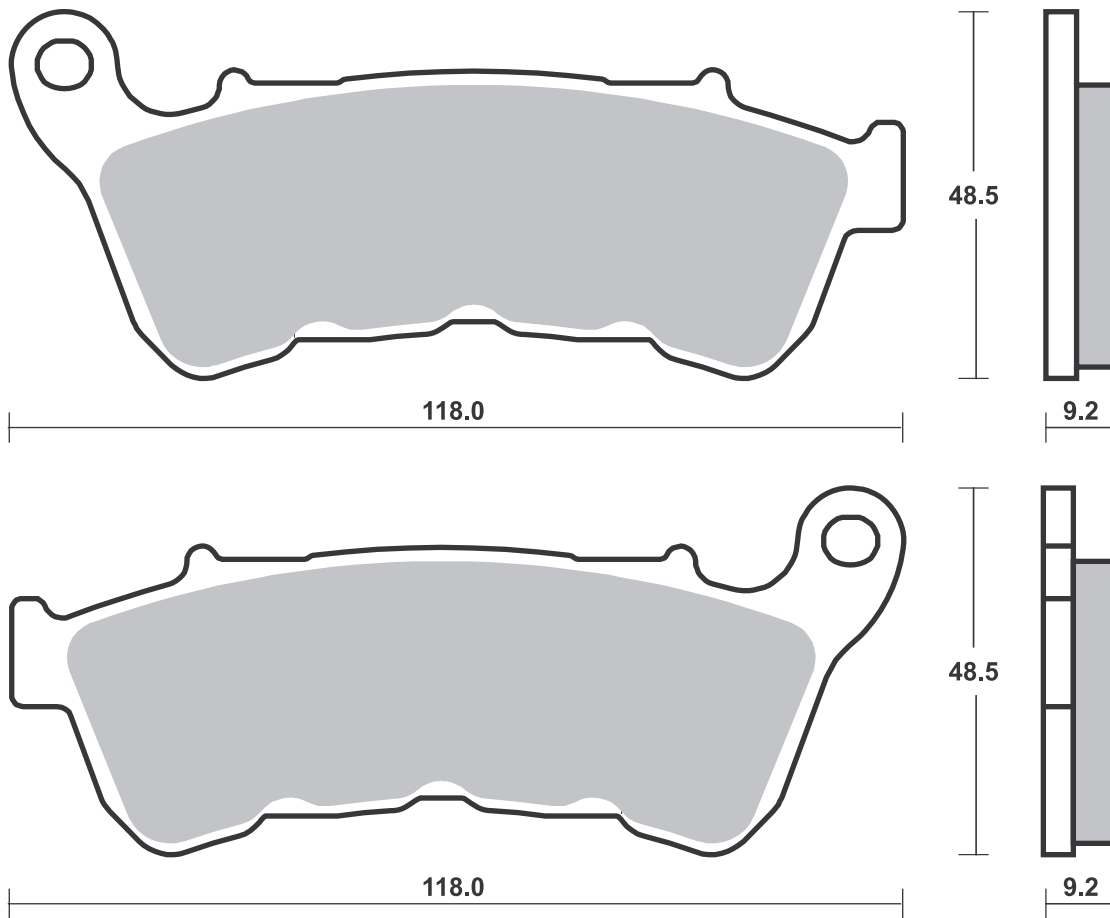

Available compounds

**HF • RSI**

**SBS 939**

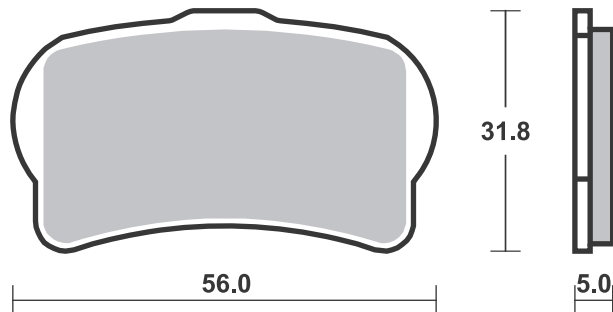



Available compounds

**HS • SP • RST**

**SBS 940**

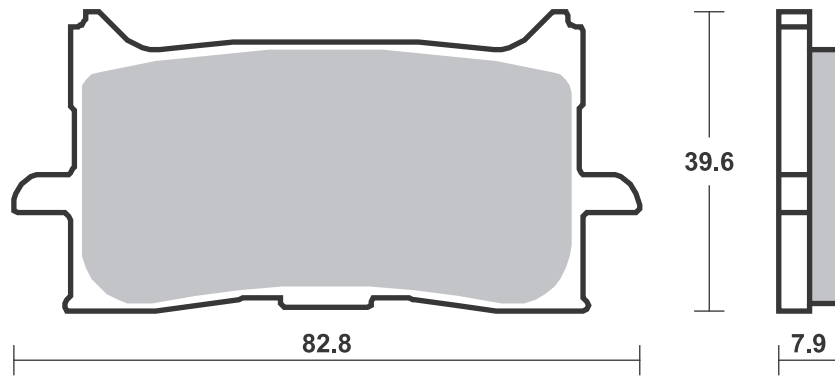

Available compounds

**LS • SP • RQ • RSI**

**SBS 941**

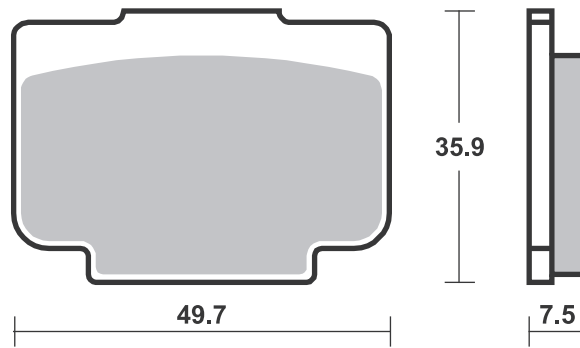

Available compounds

**LS • RQ**

**SBS 942**

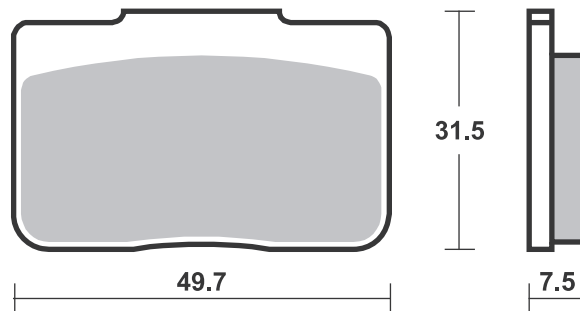



Available compounds

SI • RSI

SBS 945

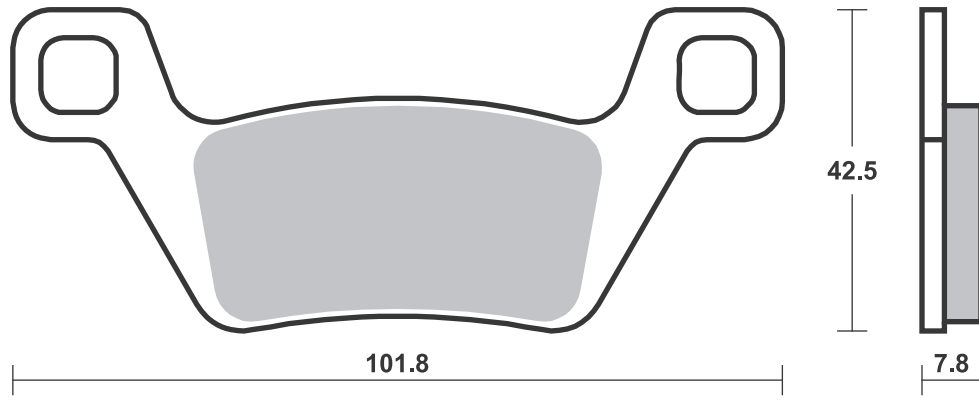

Available compounds

SI • RSI • ATS

SBS 946

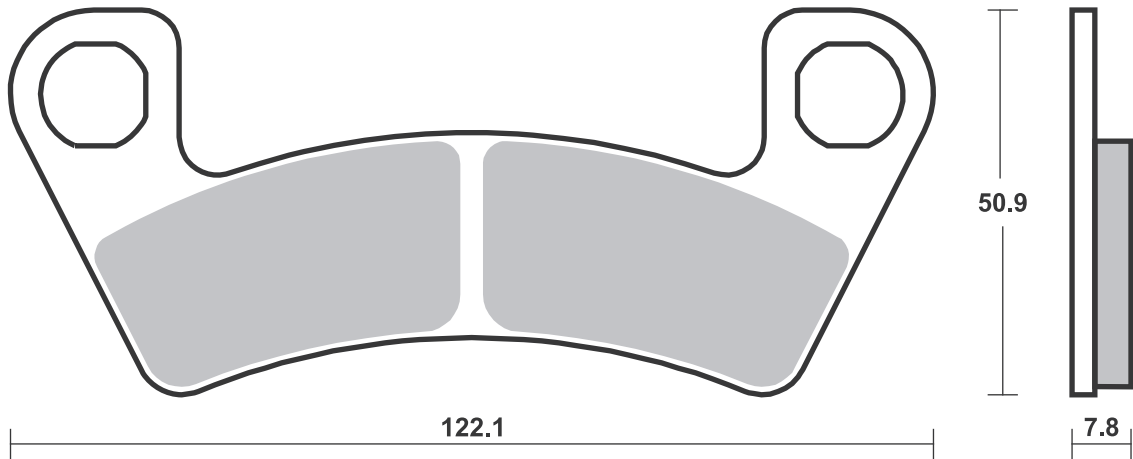



Available compounds

HS • SP • DC • RST • DS-1 • DS-2

SBS 947

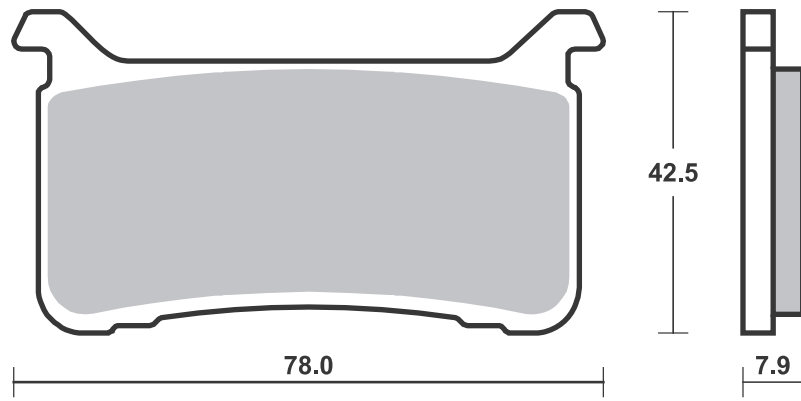

Available compounds

HS

SBS 948

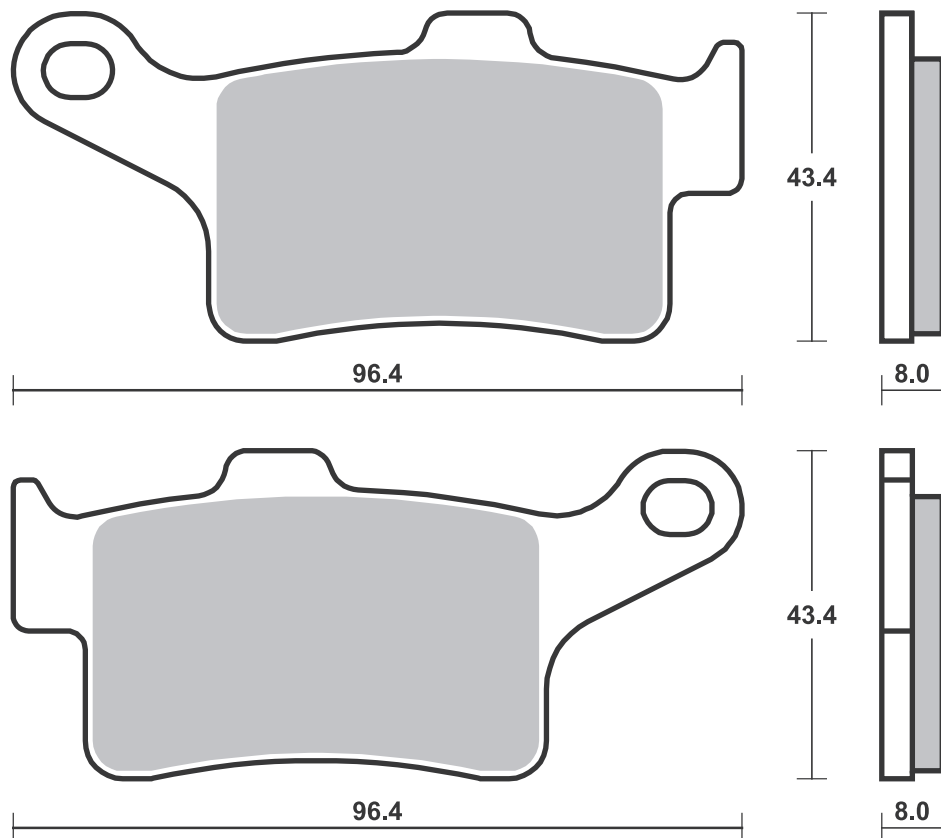





Available compounds

H.HF • H.CT • H.LS

SBS 949

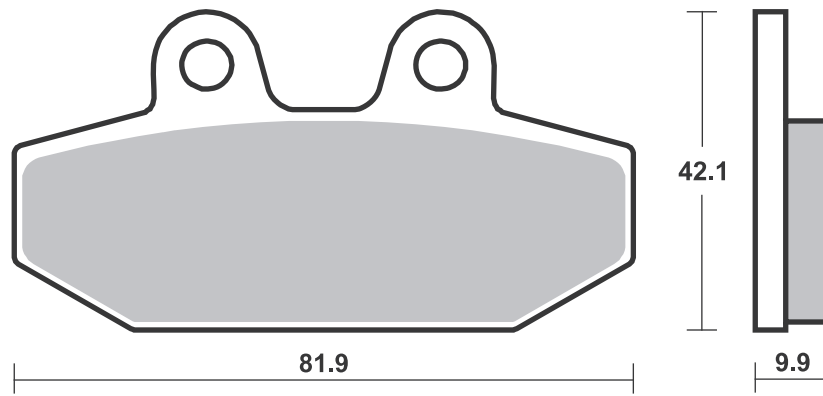

Available compounds

DS-1 • DS-2

SBS 950

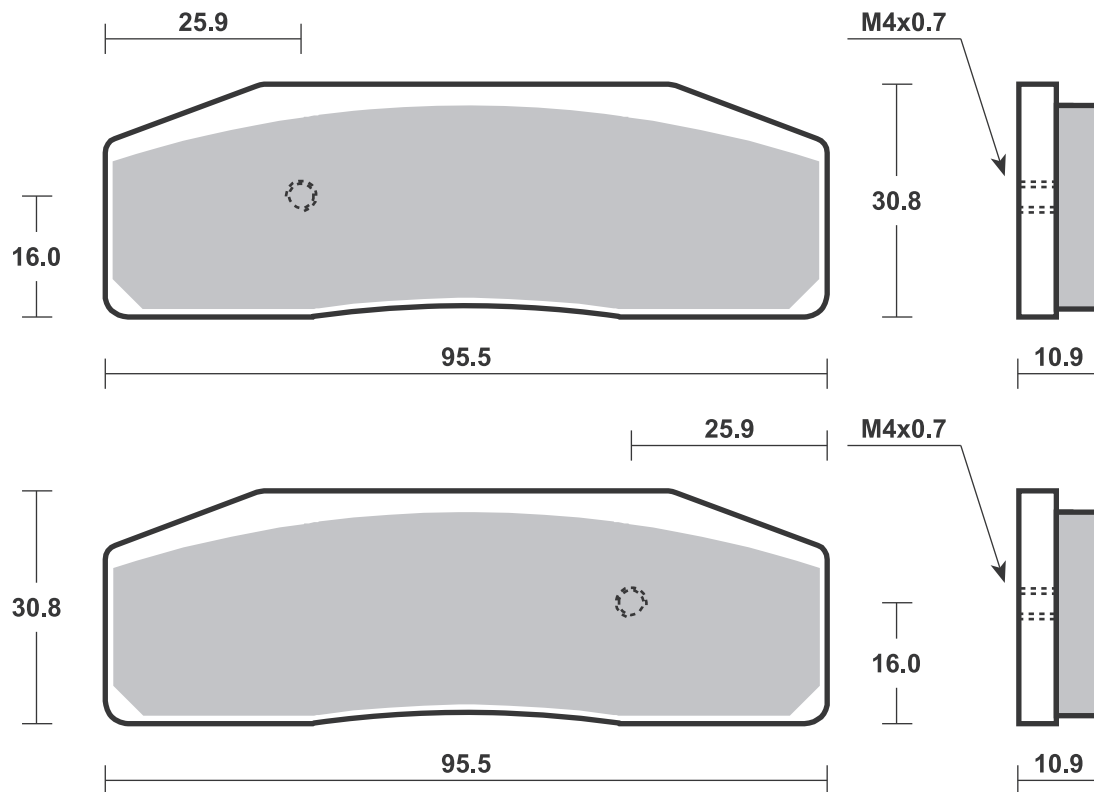



Available compounds

**HF • HS • RST**

**SBS 951**

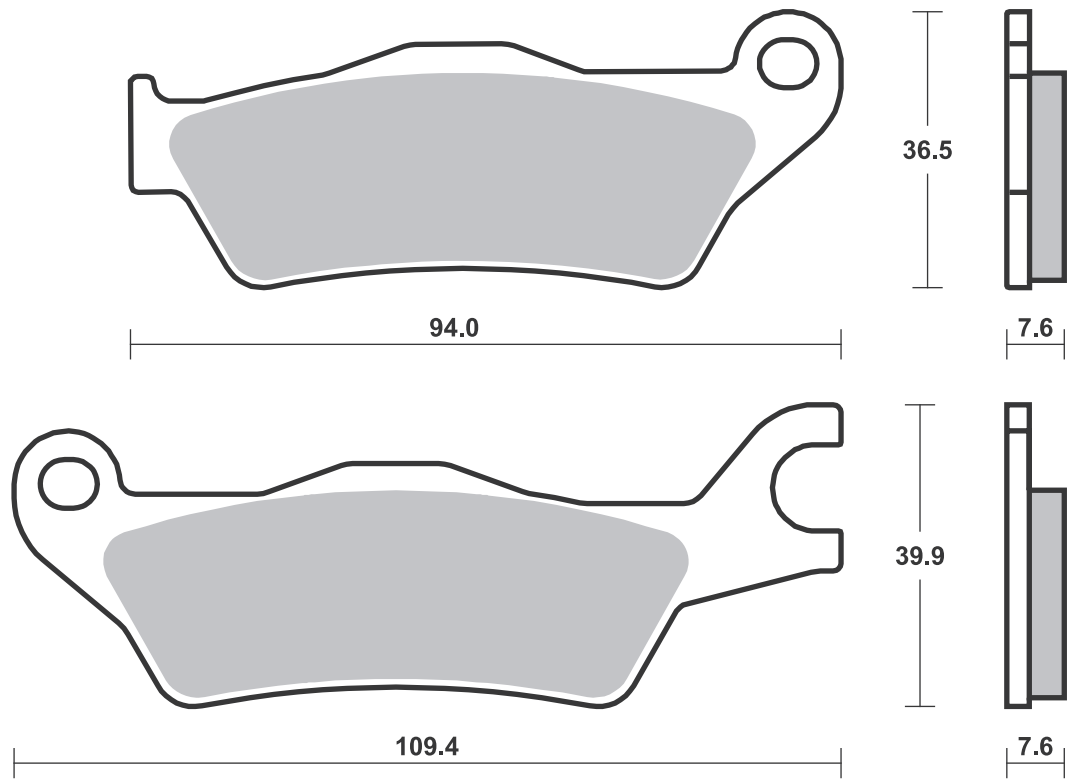

Available compounds

**HS**

**SBS 952**

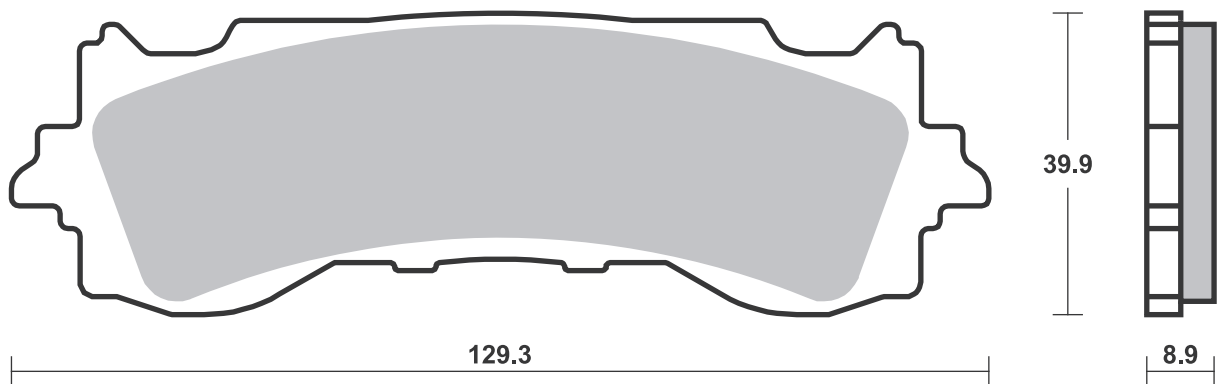



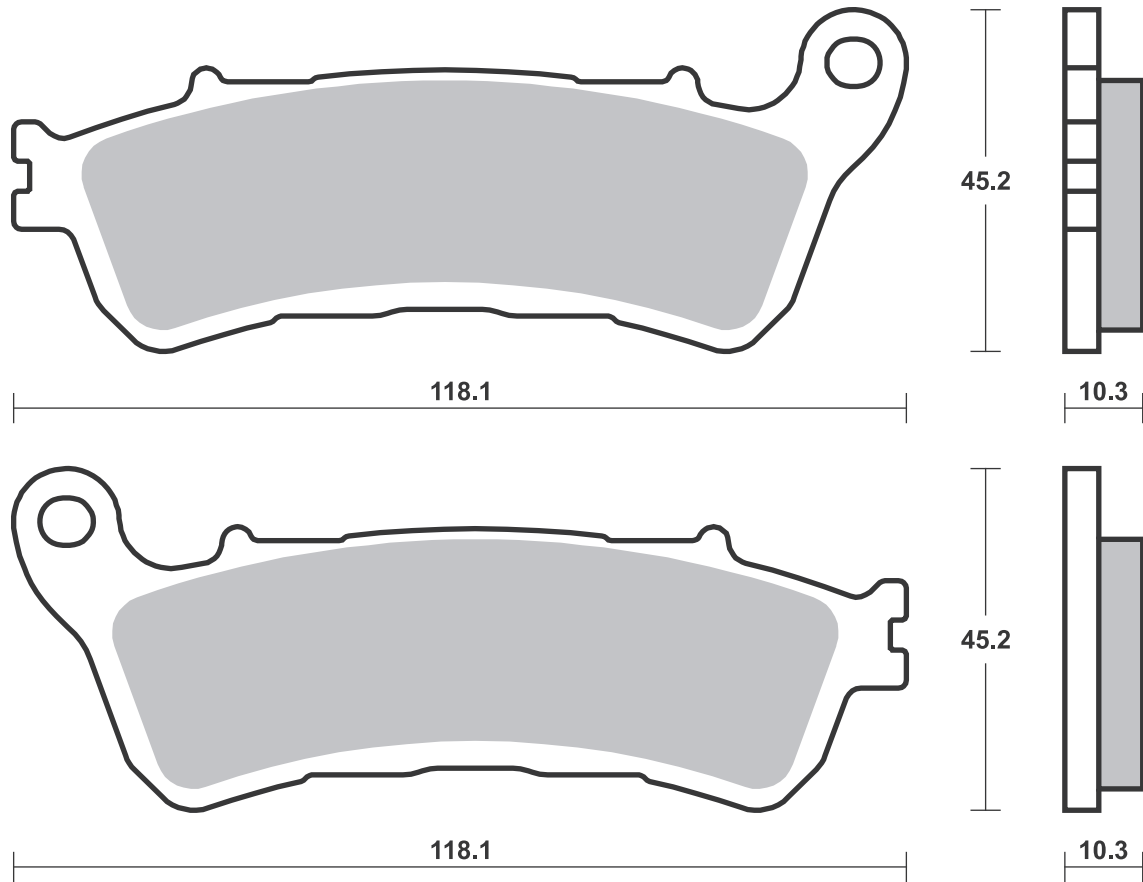



**POLARIS**

925 RZR XP Turbo 16-20 **SI**

925 RZR XP4 Turbo 16-20 **SI**

Brake Pad 1:1 Drawings,  
Compounds, Fitments

Available compounds

SI • RSI

SBS 954

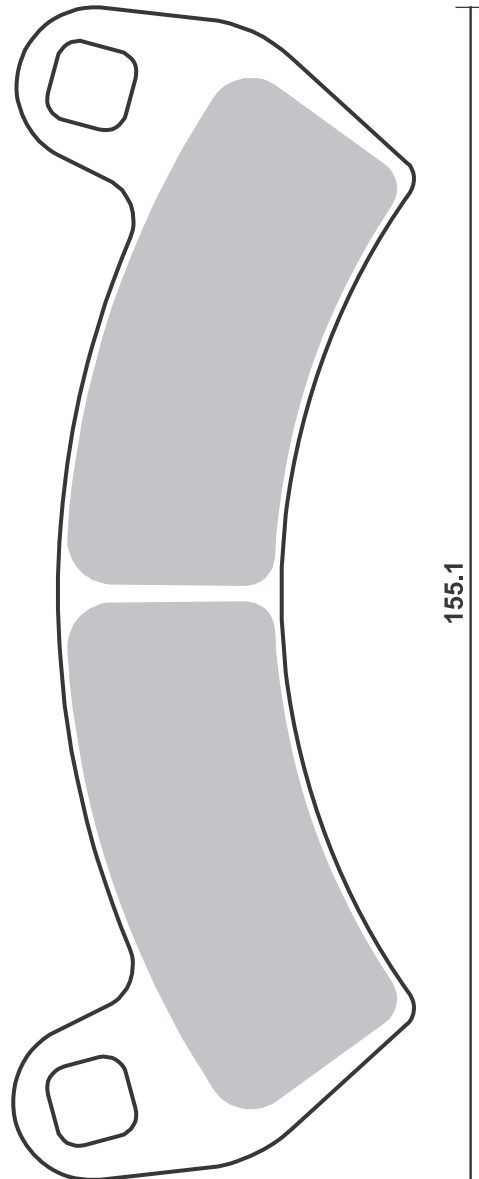
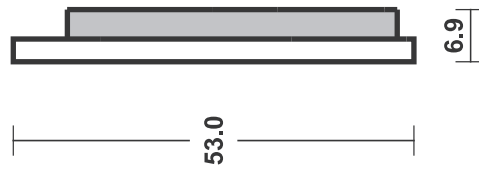

Brake Pad 1:1 Drawings,  
Compounds, Fitments





Available compounds

HS • DC • RST • DS-1 • DS-2

SBS 955

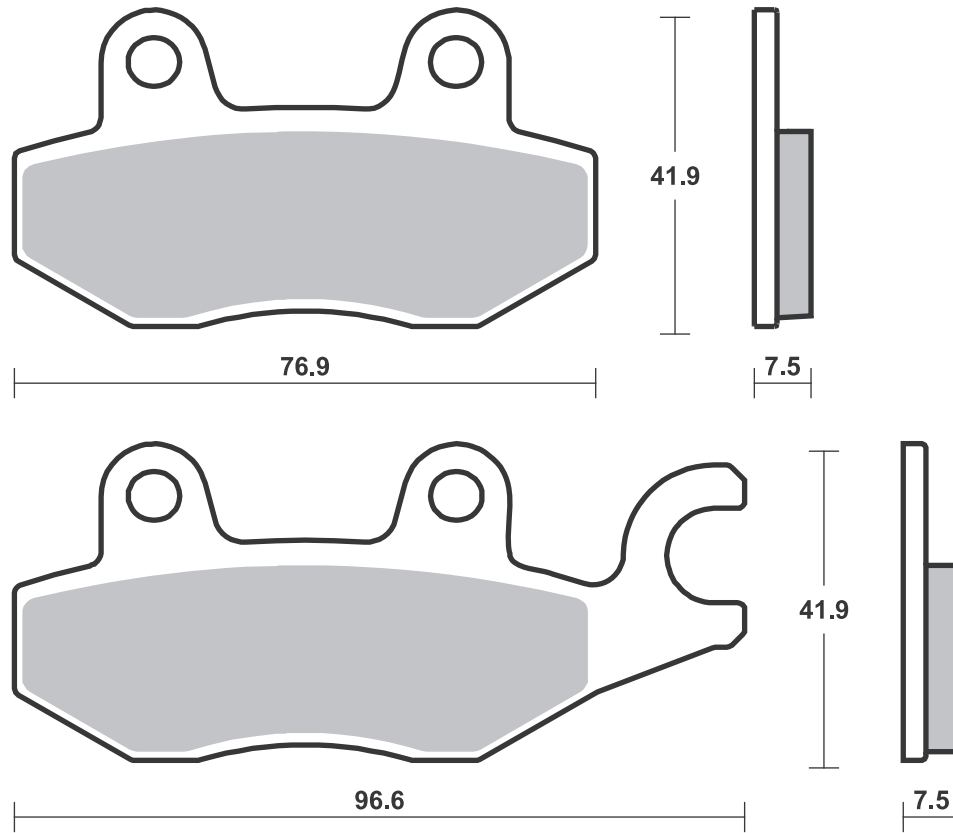



Available compounds

SI • RSI • PSI

SBS 956

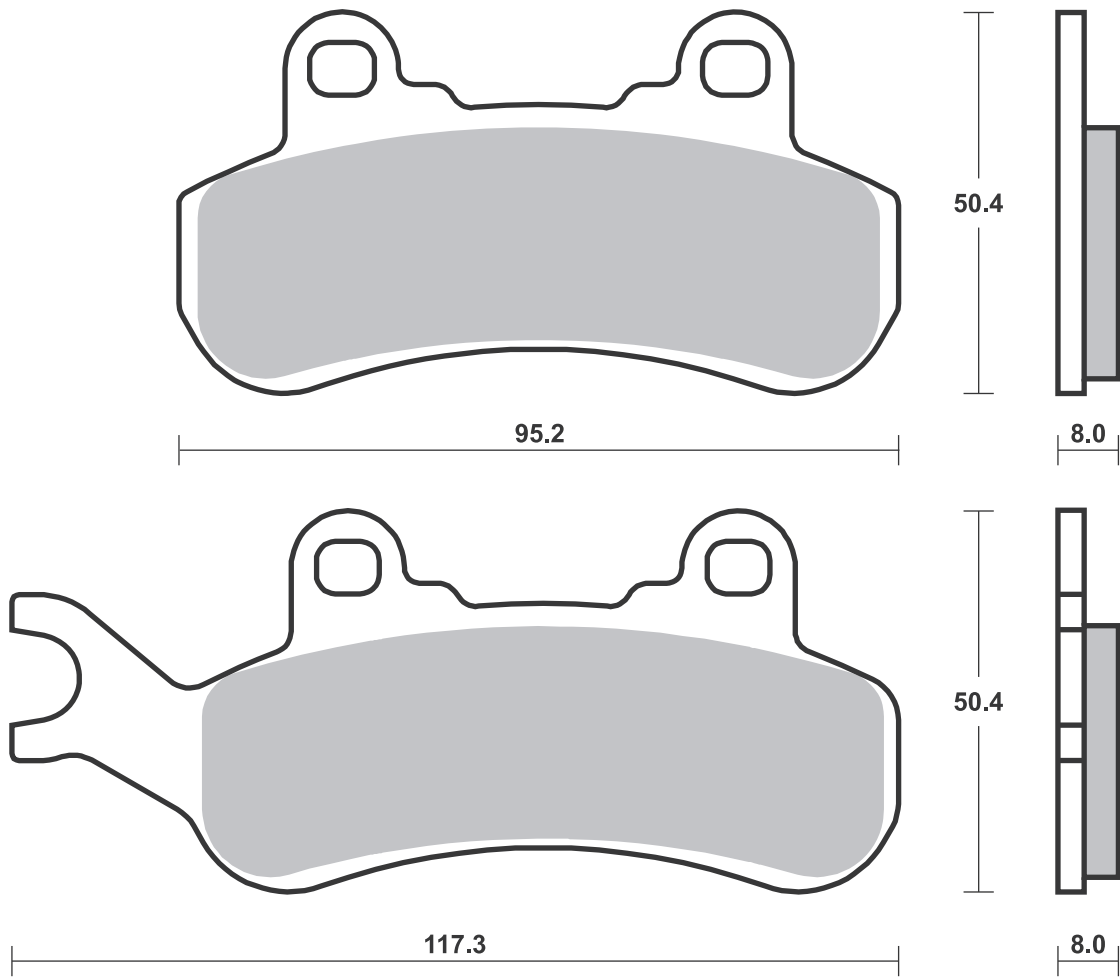



Available compounds

SI • RSI • PSI

SBS 957

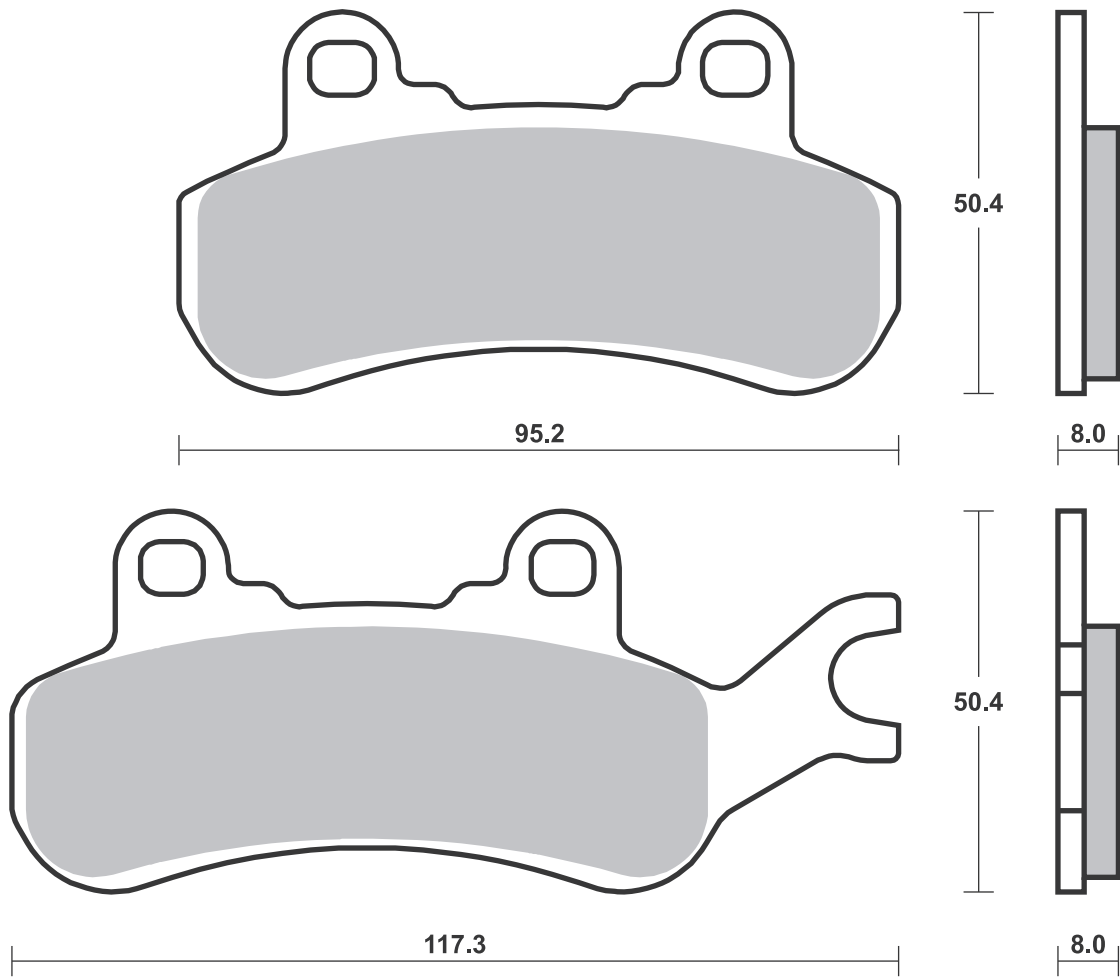

Available compounds

PSI

SBS 959

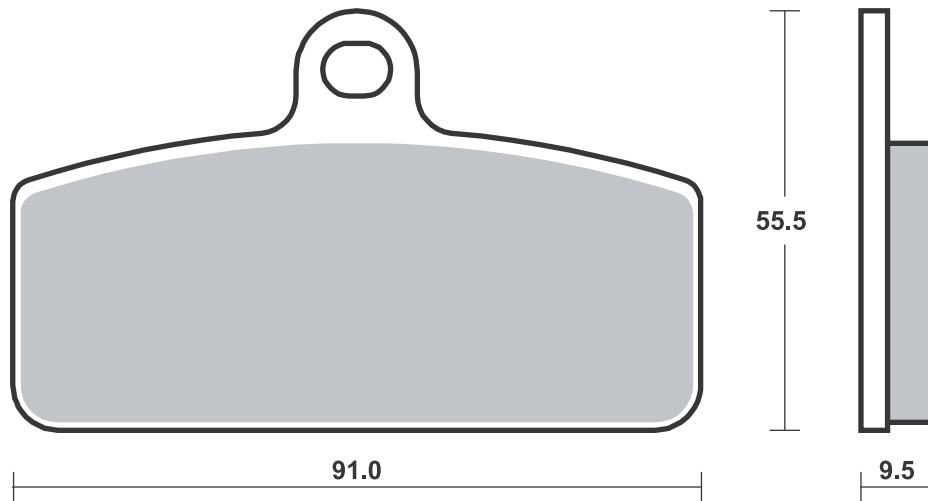



Available compounds

HS • SP • DC • RST • DS-1 • DS-2

SBS 960

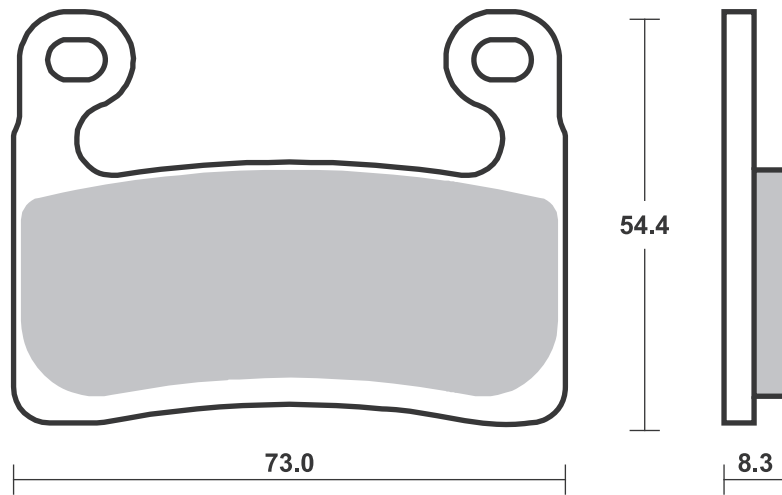

Available compounds

HF

SBS 961

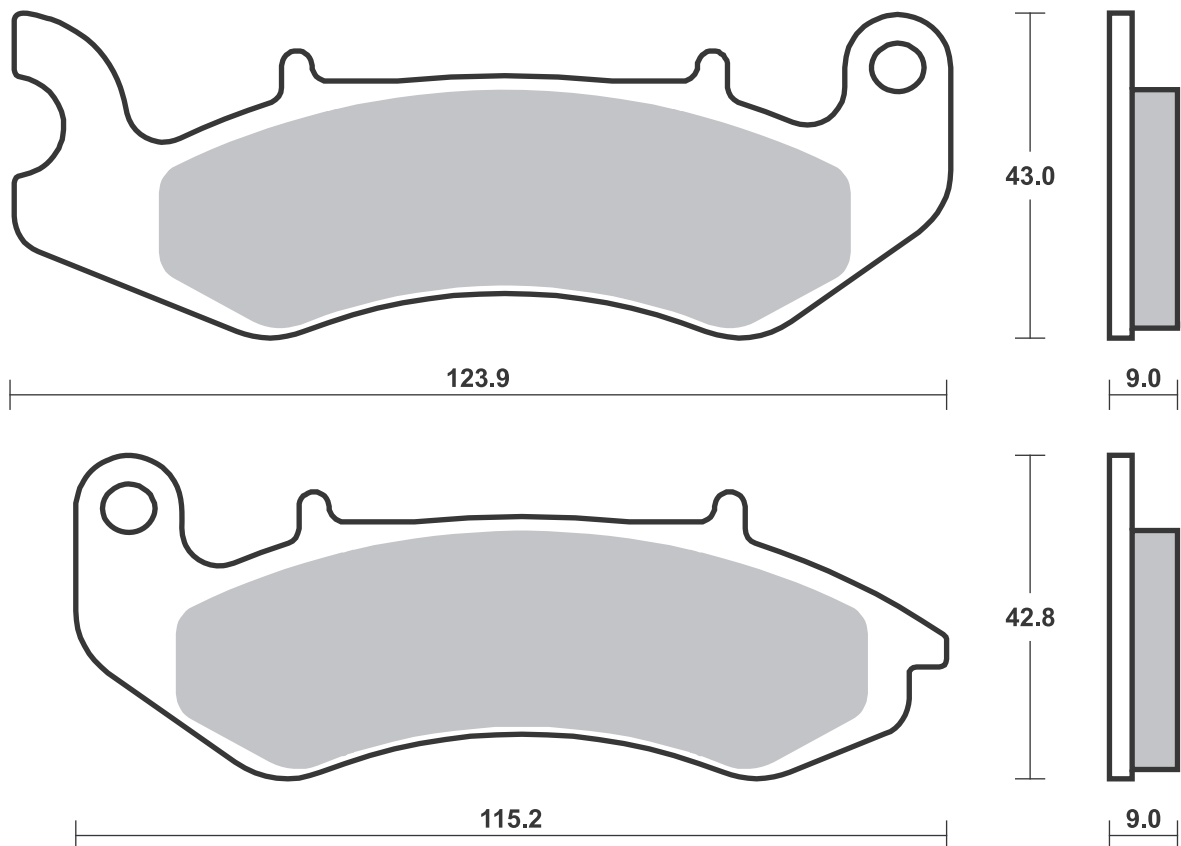





Available compounds

SP • RST

SBS 962

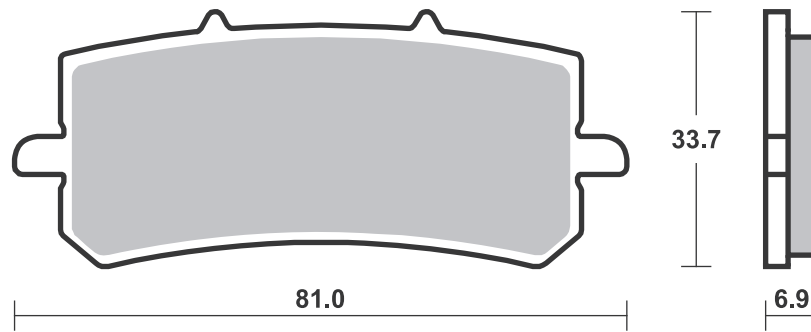

Available compounds

HF • RSI

SBS 963

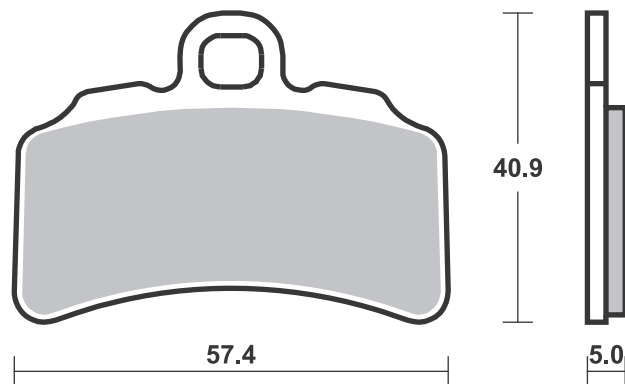



Available compounds

SI • RSI

SBS 965

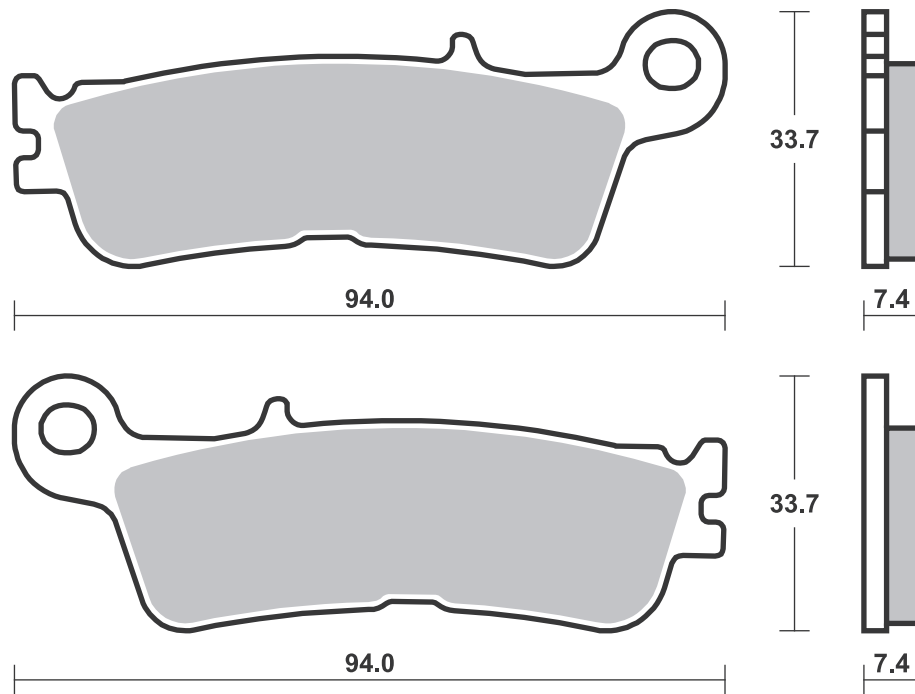

Available compounds

DS-1 • DS-2

SBS 966

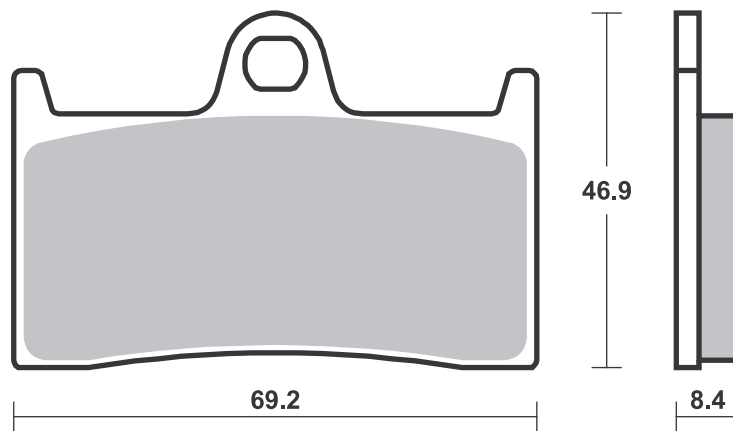



Available compounds

SI • RSI • PSI

SBS 970

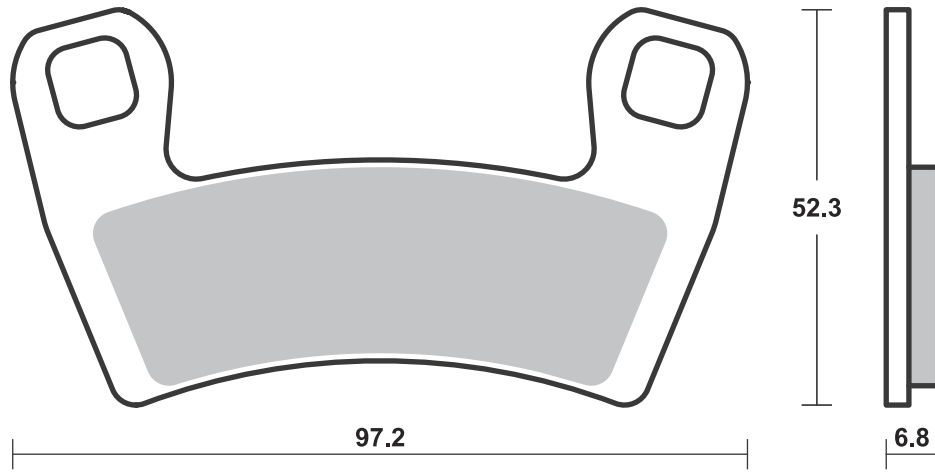

Available compounds

SI • RSI • PSI

SBS 971

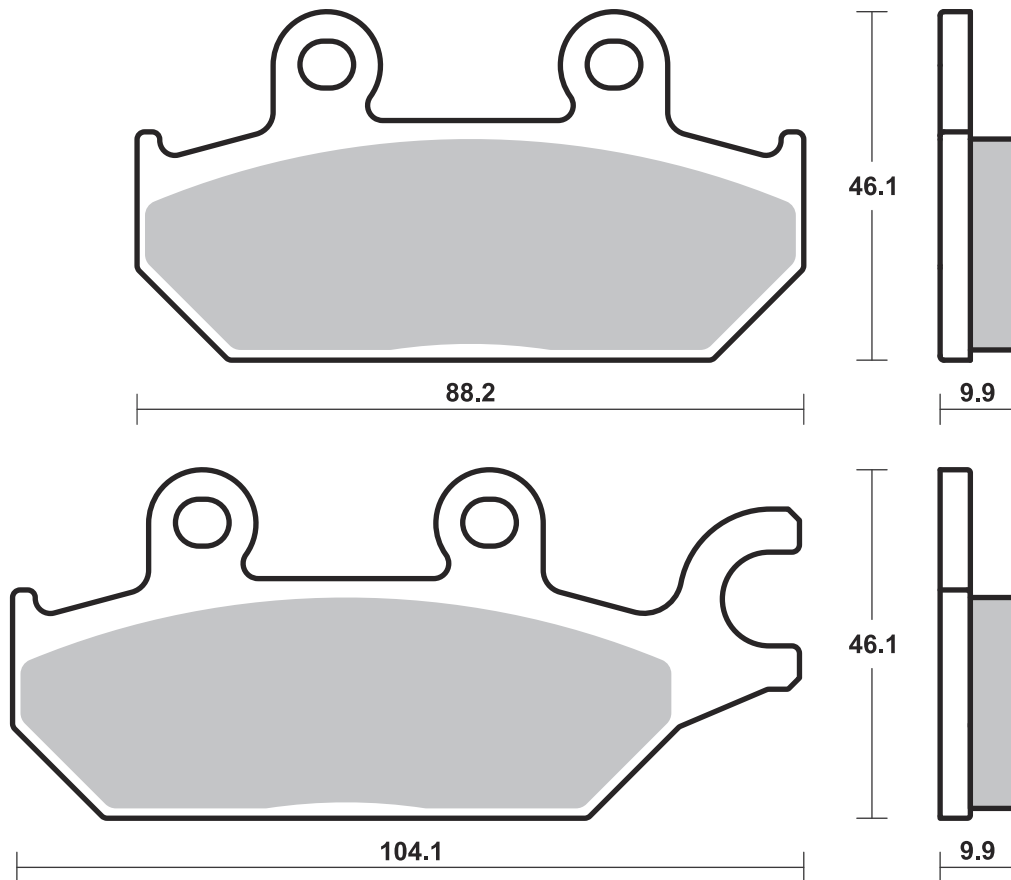

**SBS 972** Recommended compound

<b>CAN-AM</b>			
800 Commander			
MAX R EFI	18-20	<b>PSI</b>	
800 Commander			
R EFI	18-18	<b>PSI</b>	
1000 Commander	16-17	<b>PSI</b>	
1000 Commander			
MAX	14-17	<b>PSI</b>	
1000 Commander			
MAX R EFI	18-19	<b>PSI</b>	
1000 Commander			
R EFI	18-20	<b>PSI</b>	
1000 Maverick	14-18	<b>PSI</b>	
1000 Maverick			
MAX	14-18	<b>PSI</b>	

**YAMAHA**

YXC	700 Viking VI	15-16	<b>PSI</b>
YXC	700 Viking VI EPS	15-21	<b>PSI</b>
YXC	700 Viking VI EPS		
	Special		
	Edition	16-17	<b>PSI</b>
YXE	700 Wolverine	16-18	<b>PSI</b>
YXE	700 Wolverine EPS	17-17	<b>PSI</b>
YXE	700 Wolverine		
	R-Spec	16-16	<b>PSI</b>
YXE	700 Wolverine		
	R-Spec EPS	16-18	<b>PSI</b>
YXE	700 Wolverine		
	R-Spec EPS		
	SE	16-16	<b>PSI</b>



<b>YAMAHA</b>			
YXE	700 Wolverine		
	R-Spec EPS		
	Special Edition	17-17	<b>PSI</b>
YXM	700 Viking	14-20	<b>PSI</b>
YXM	700 Viking EPS	14-21	<b>PSI</b>
YXM	700 Viking EPS SE	14-17	<b>PSI</b>
YXM	700 Viking EPS		
	Special E	19-19	<b>PSI</b>
YXM	700 Viking EPS		
	Special Edition	16-16	<b>PSI</b>
YXE	850 Wolverine X2	19-19	<b>PSI</b>
YXE	850 Wolverine X2		
	EPS	20-20	<b>PSI</b>
YXE	850 Wolverine X2		
	R-Spec	19-20	<b>PSI</b>
YXE	850 Wolverine X2		
	XTR	20-20	<b>PSI</b>
YXF	850 Wolverine X4	18-20	<b>PSI</b>
YXF	850 Wolverine X4		
	SE	19-19	<b>PSI</b>
YXF	850 Wolverine X4		
	Special	19-19	<b>PSI</b>
YXF	850 Wolverine X4		
	Special Edition	18-18	<b>PSI</b>
YXF	850 Wolverine X4		
	XTR	20-20	<b>PSI</b>

**SBS 973** Recommended compound

<b>YAMAHA</b>			
YXC	700 Viking VI	15-16	<b>PSI</b>
YXC	700 Viking VI EPS	15-21	<b>PSI</b>
YXC	700 Viking VI EPS		
	Special		
	Edition	16-17	<b>PSI</b>
YXE	700 Wolverine	16-18	<b>PSI</b>
YXE	700 Wolverine EPS	17-17	<b>PSI</b>
YXE	700 Wolverine		
	R-Spec	16-16	<b>PSI</b>
YXE	700 Wolverine		
	R-Spec EPS	16-18	<b>PSI</b>
YXE	700 Wolverine		
	R-Spec EPS		
	SE	16-16	<b>PSI</b>
YXE	700 Wolverine		
	R-Spec EPS		
	Special		
	Edition	17-17	<b>PSI</b>
YXM	700 Viking	14-20	<b>PSI</b>
YXM	700 Viking EPS	14-21	<b>PSI</b>
YXM	700 Viking EPS SE	14-17	<b>PSI</b>
YXM	700 Viking EPS		
	Special E	19-19	<b>PSI</b>
YXM	700 Viking EPS		
	Special		
	Edition	16-16	<b>PSI</b>
YXE	850 Wolverine X2	19-19	<b>PSI</b>
YXE	850 Wolverine X2		
	EPS	20-20	<b>PSI</b>



<b>YAMAHA</b>			
YXE	850 Wolverine X2		
	R-Spec	19-20	<b>PSI</b>
YXE	850 Wolverine X2		
	XTR	20-20	<b>PSI</b>
YXF	850 Wolverine X4	18-20	<b>PSI</b>
YXF	850 Wolverine X4		
	SE	19-19	<b>PSI</b>
YXF	850 Wolverine X4		
	Special	19-19	<b>PSI</b>
YXF	850 Wolverine X4		
	Special Edition	18-18	<b>PSI</b>
YXF	850 Wolverine X4		
	XTR	20-20	<b>PSI</b>

Available compounds

SI • RSI • PSI

SBS 972

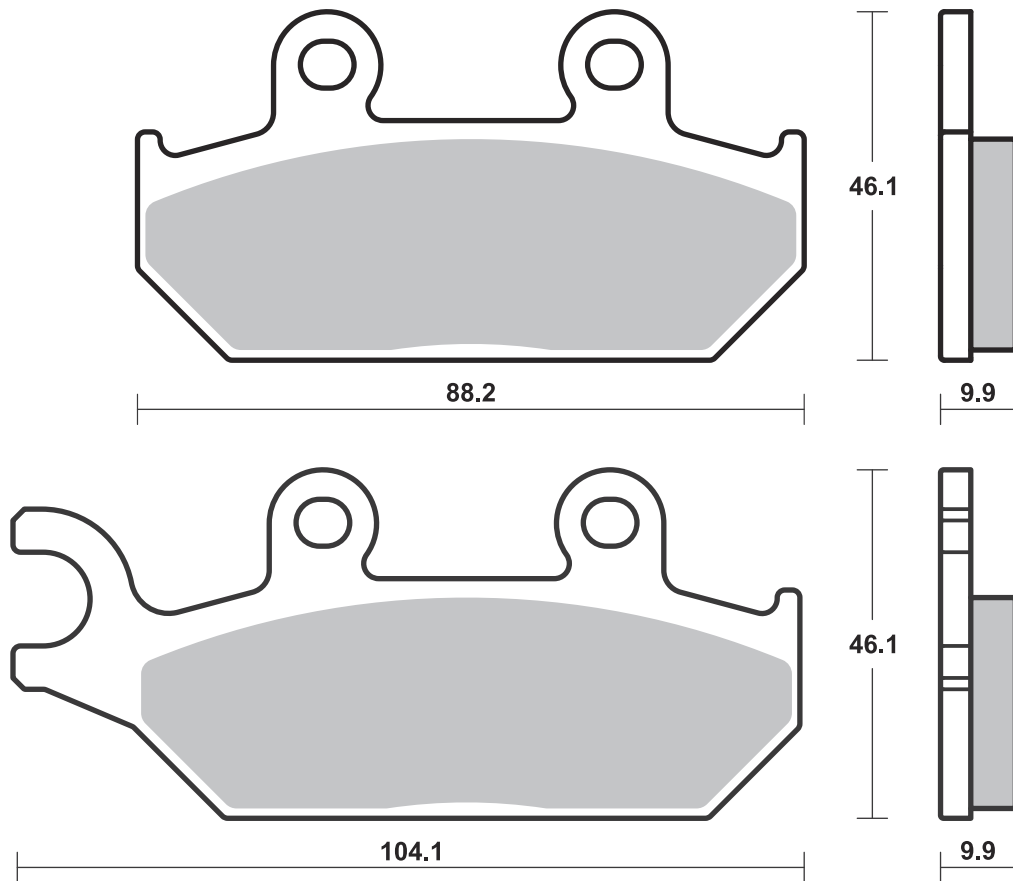

Available compounds

SI • RSI • PSI

SBS 973

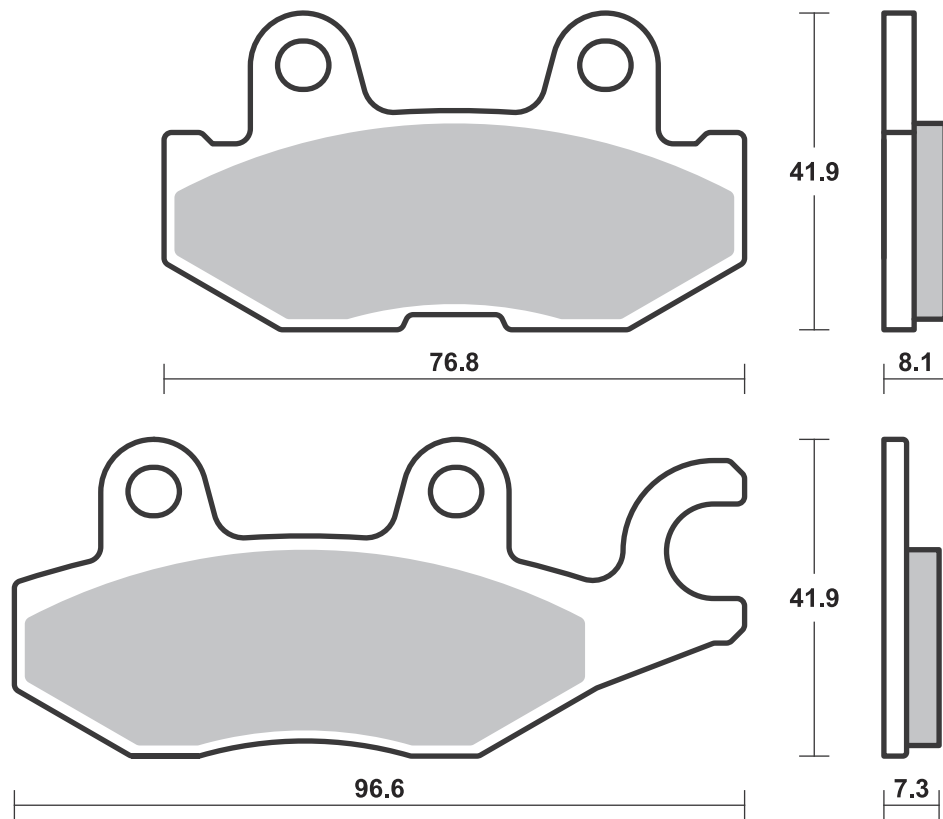





Available compounds

SI • RSI • PSI

SBS 974

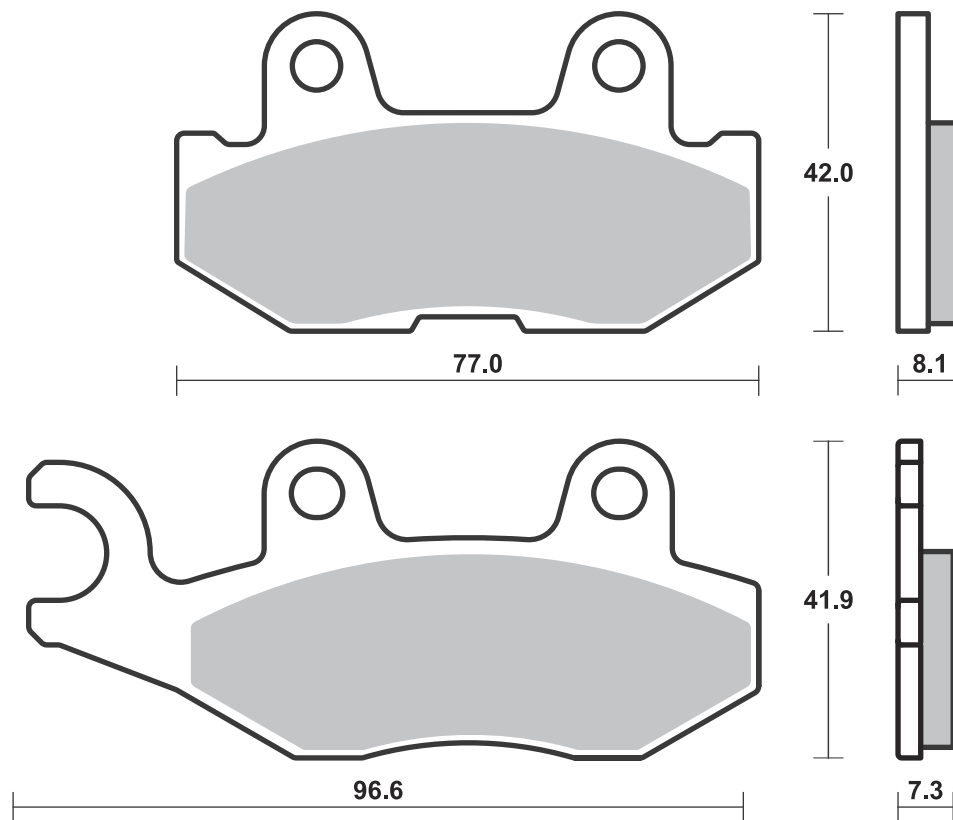

Available compounds

SI • RSI • PSI

SBS 975

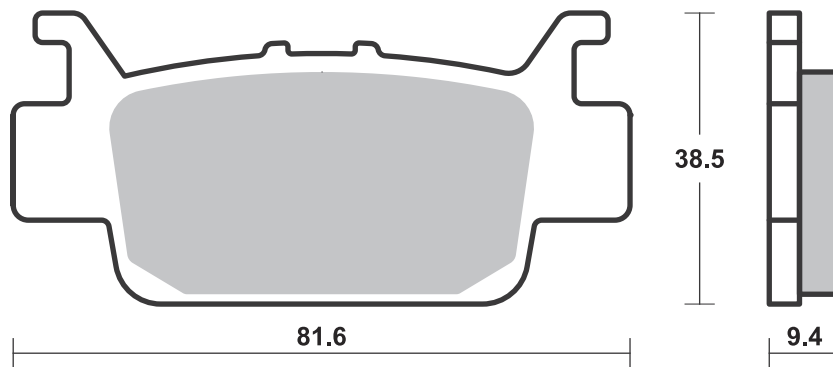



Available compounds

SI • RSI • PSI

SBS 976

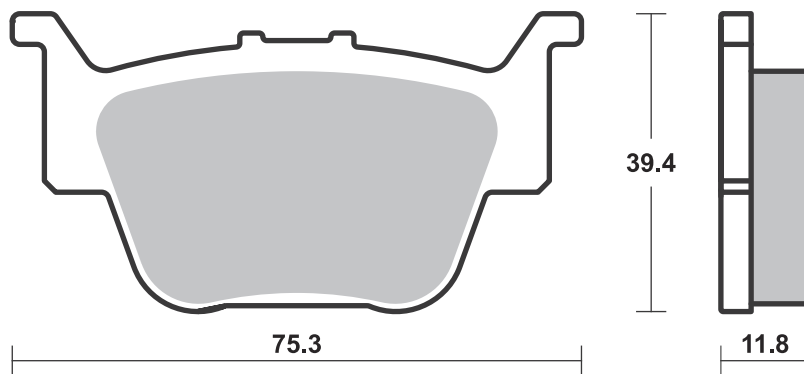

Available compounds

SI • RSI

SBS 977

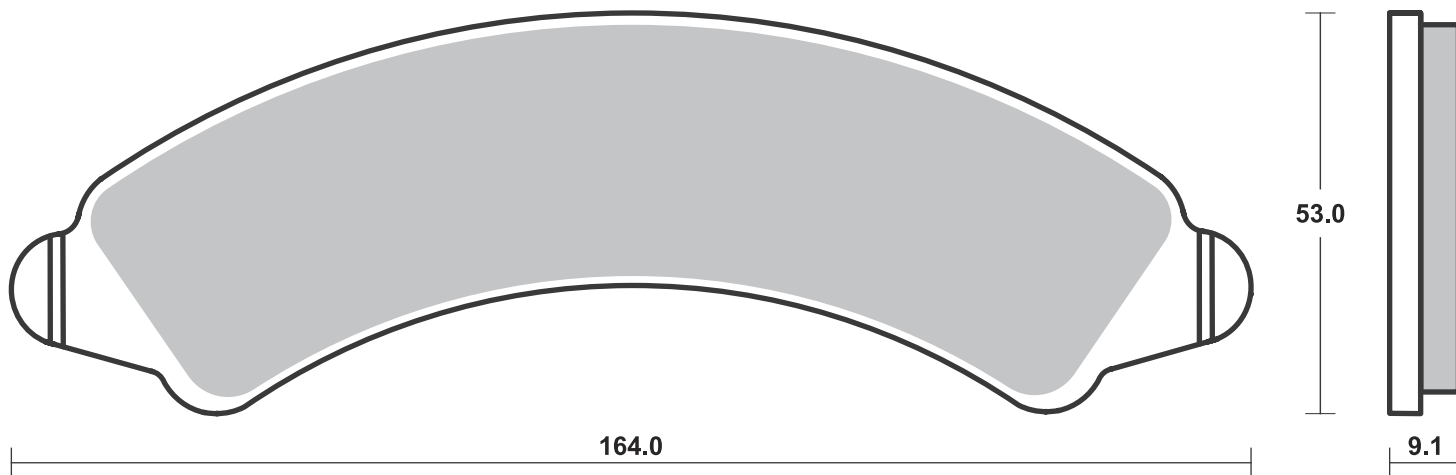

Available compounds

SI • RSI • PSI

SBS 978

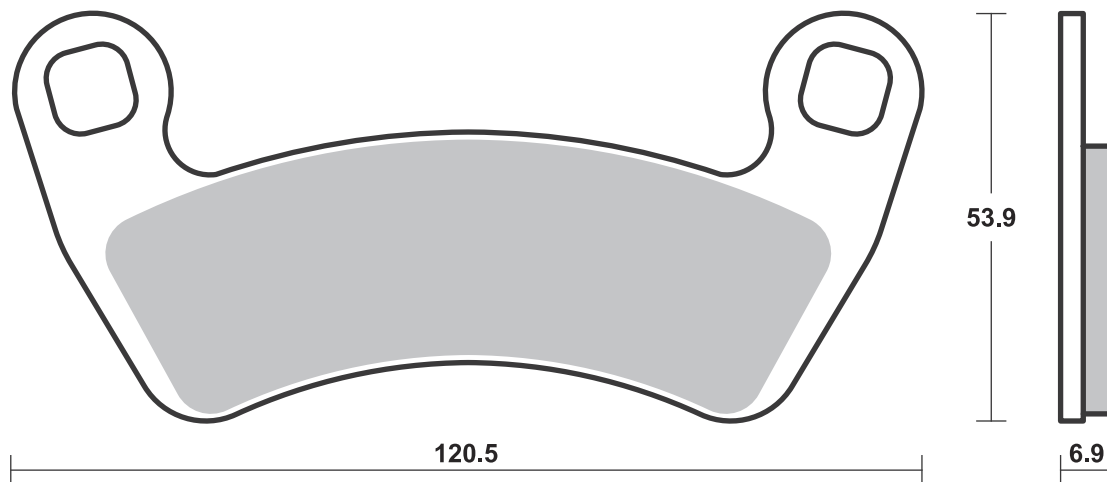



Available compounds

SI • RSI • PSI

SBS 979

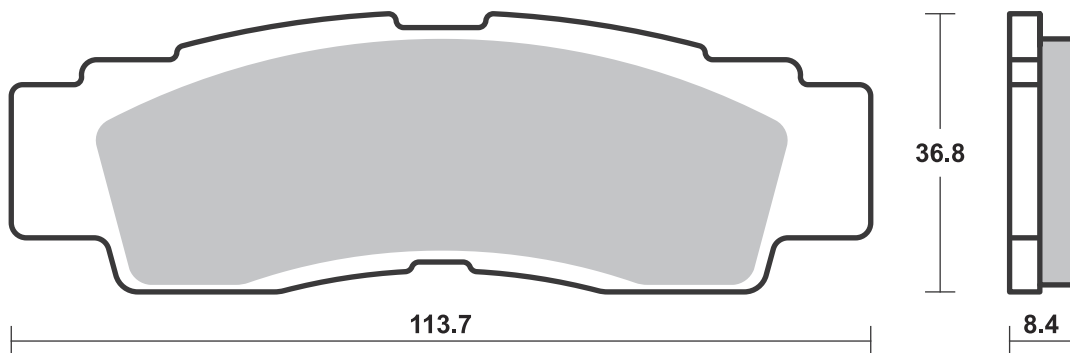

Available compounds

SI • RSI • PSI

SBS 980

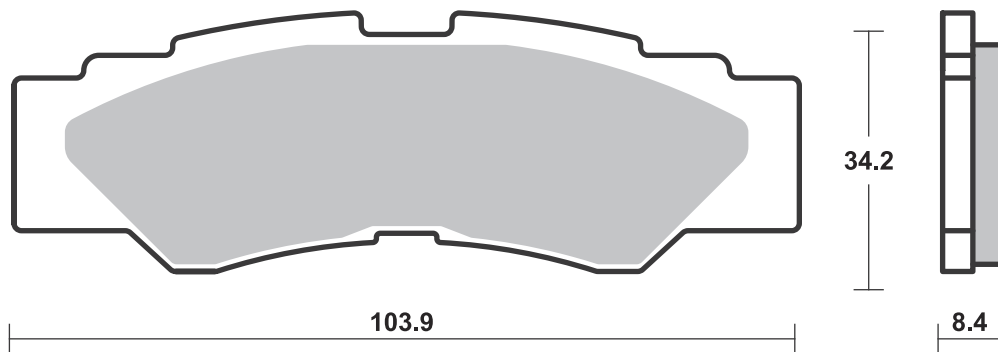

Available compounds

SI • RSI • PSI

SBS 981

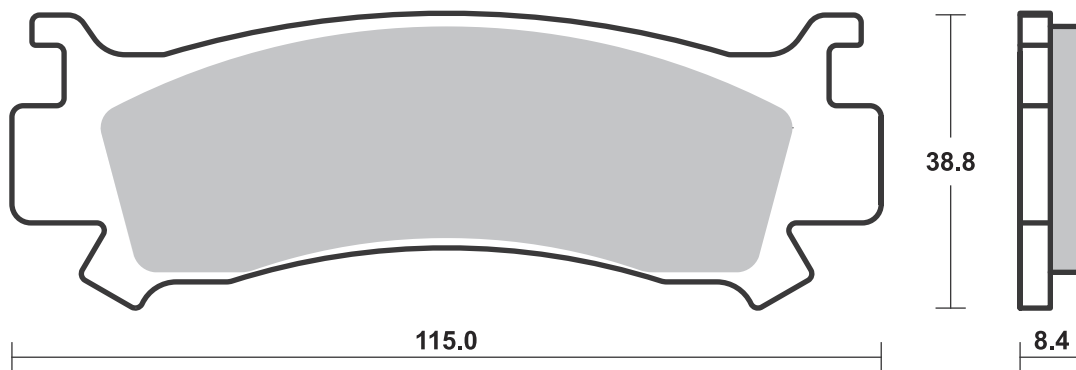



Available compounds

SI • RSI • PSI

SBS 982

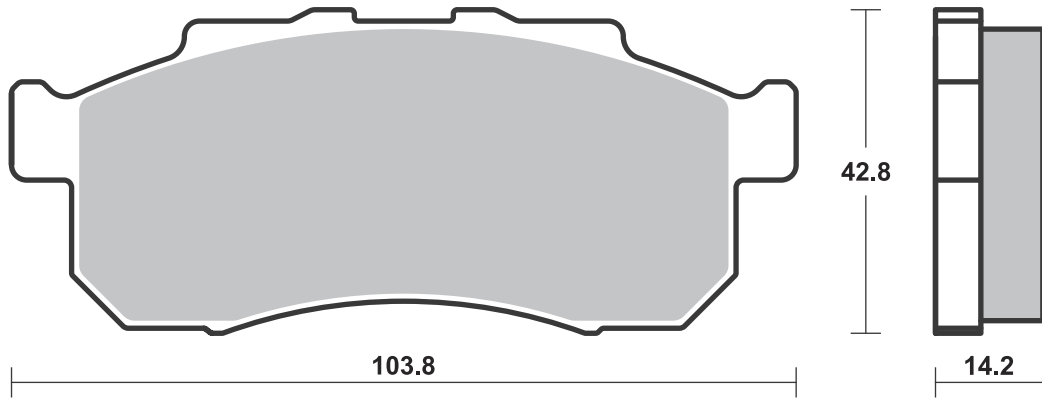

Available compounds

HS

SBS 983

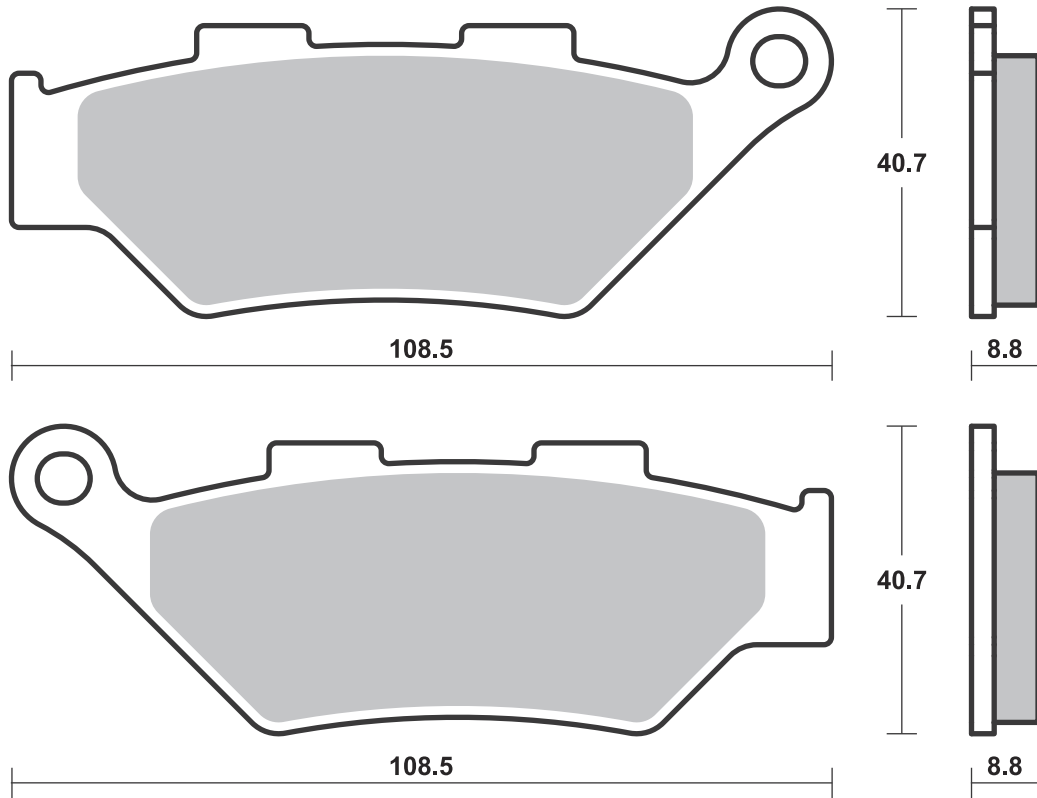





Available compounds

LS • RQ

SBS 984

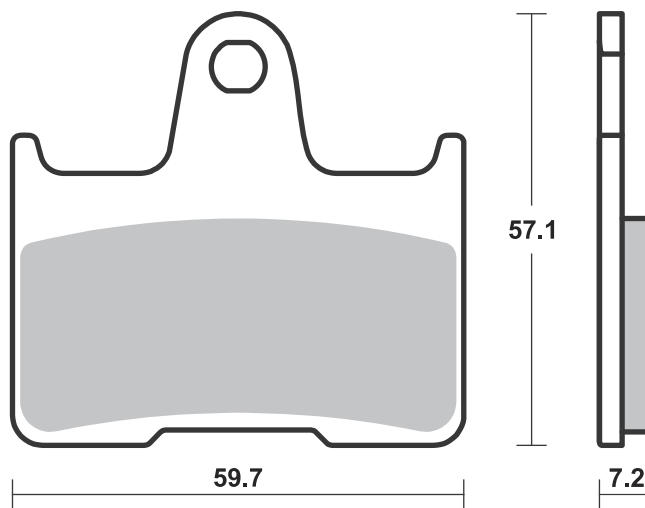

Available compounds

HS • SP • DC • RST • DS-1 • DS-2

SBS 985

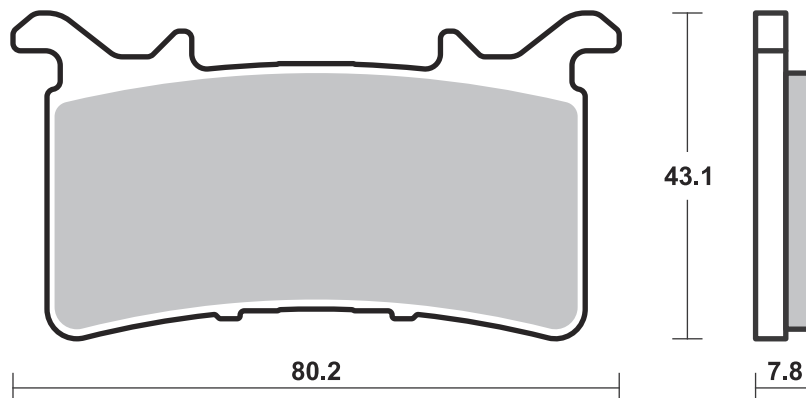

Available compounds

SI • PSI

SBS 986

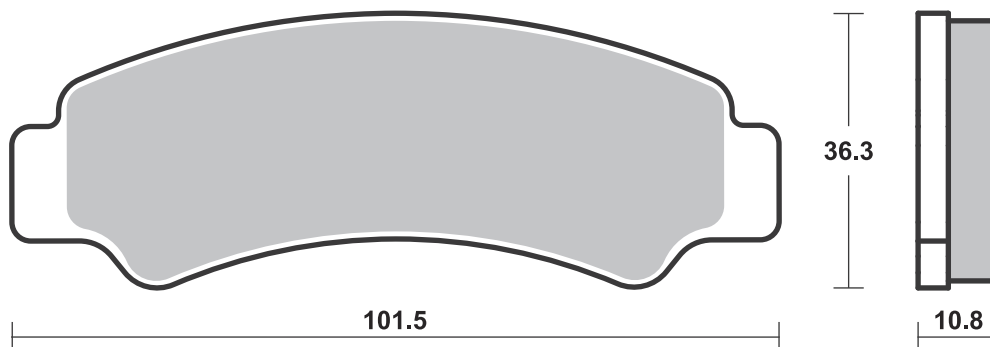

**SBS 987** Recommended compound



**CF MOTO**

500 U-Force	18-20	<b>PSI</b>
500 Z-Force	18-21	<b>PSI</b>
600 C-Force	20-21	<b>PSI</b>
600 C-Force		
Touring	20-21	<b>PSI</b>
800 U-Force	18-21	<b>PSI</b>
800 Z-Force EX	18-21	<b>PSI</b>
800 Z-Force Trail	18-21	<b>PSI</b>
1000 Z-Force	18-19	<b>PSI</b>

**SBS 991** Recommended compound



**YAMAHA**

MXT 850 Niken	18-22	<b>LS</b>
MXT 850 Niken GT	19-22	<b>LS</b>

Brake Pad 1:1 Drawings, Compounds, Fitments

Available compounds

SI • PSI

SBS 987

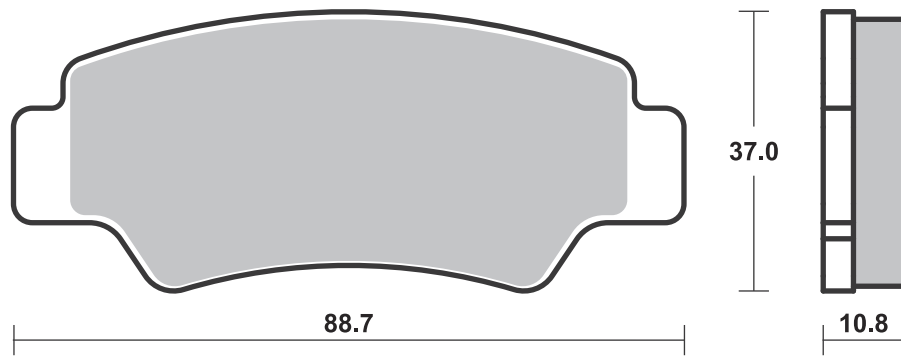

Available compounds

LS

SBS 991

# NEW! Get the brake feel you want!



Find the right brake pad compound for you and your bike with the new Compound Selector at [sbsbrakes.com](http://sbsbrakes.com)

Find the right compound for you and your bike

Click Start Now, answer 2-3 questions and get the answer right away

START NOW



@sbsbrakes | [sbsbrakes.com](http://sbsbrakes.com)

HI-TECH BRAKE SOLUTIONS  
MADE IN EUROPE

# BRAKE SHOES

## DRAWINGS, FITMENTS

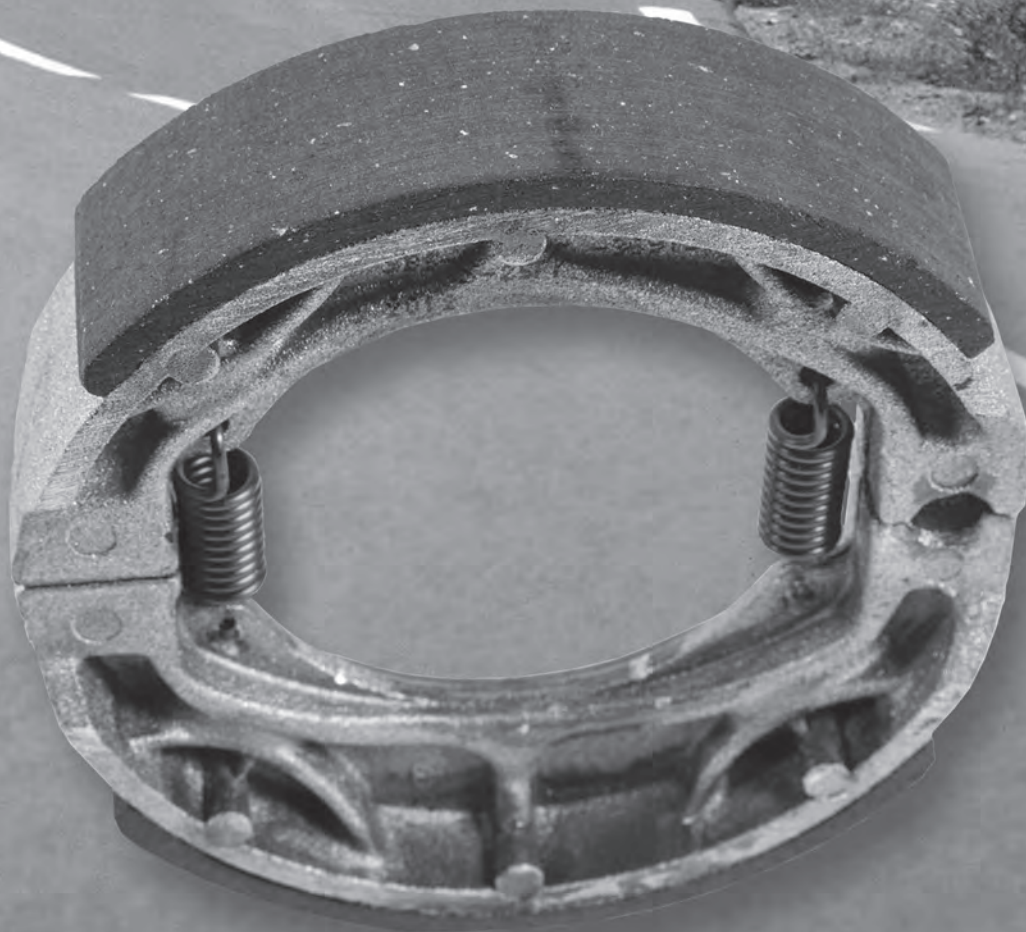



HONDA			
CRF	50 F	04-21	• •
NA	50 Express	79-81	•
NB	50 ME, Aero	83-87	•
NC	50 Express	77-80	• •
NC	50 Express	81-83	•
NN	50 MD Gyro	84-84	• •
NQ	50 D, Spree	84-87	• •
PA	50	78-81	•
PA	50	82-83	• •
QR	50	93-03	•
QR	50 ED, EF	82-92	•
SA	50 Elite LX, SR	88-93	•
SB	50	88-89	• •
TG	50 M Gyro S	85-86	• •
XR	50 R	00-03	• •
Z	50 R, RD	80-99	• •
CT	70	91-94	• •



SUZUKI			
DR-Z	50	19-21	• •
DR-Z	70	08-21	• •

YAMAHA			
TT-R	50	06-21	• •

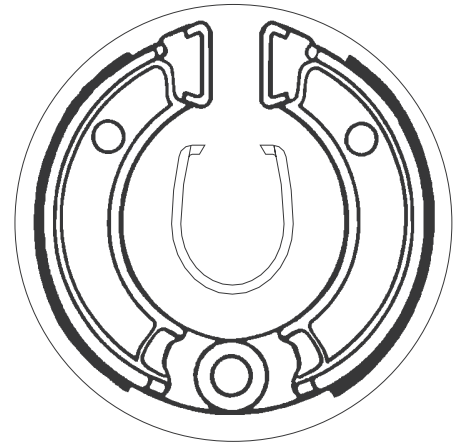

HONDA			
NA	50 Express	79-81	•
NB	50 ME, Aero	83-87	•
NC	50 Express	81-83	•
NH	50 Lead	83-83	•
NH	50 Lead	86-94	•
NH	50 Lead	(Drum vers.) 94-94	•
NH	50 Lead SS,MR, MSE	84-85	•
NS-1	50	91-94	•
PX	50	82-83	•
QR	50 ED, EF	82-92	•
SA	50 Elite LX, SR	88-93	•
NH	80 MD Lead, Aero	83-84	•

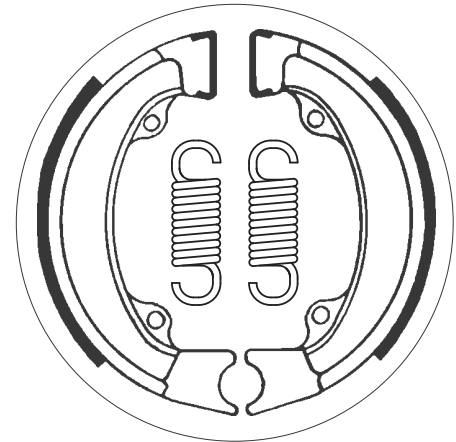

APRILIA			
SR	50 Replica	94-96	•
SR	50 Replica (Liquid Cooled)	96-96	•
SR	50 WWW, Netscaper	97-99	•

E-TON			
RXL	150 Viper	07-07	•

HONDA			
NH	50 Lead	83-83	•
NH	50 Lead (Drum vers.)	94-94	•
PK	50 Walaroo DX-STD	90-01	•
R	50 Monkey	88-88	•
ATC	70 K1	76-77	•



HONDA			
C	70 all models	75-83	• •
CH	80 Elite	85-88	•
NH	80 Aero	85-85	•
NH	80 MD Lead, Aero	83-84	•
EZ	90 Cub	90-95	• •
TRX	90	93-01	•
ANF	125 i Innova	07-11	•
ANF	125 Innova	03-06	•
ATC	125 ME, MF, MG, MH	84-87	•
CH	125 D, E, Spacy, Elite	83-84	• •
NH	125 Lead Scooter	86-87	•
TRX	125	85-88	•
XL	125 K3	79-79	•
CH	150 D Elite	85-87	• •
ATC	185 A, S, SB	80-83	•





**HONDA**

ATC	200	81 - 83	•
ATC	200 E Big Red	82 - 83	•
ATC	200 ES Big Red	84 - 84	•
ATC	200 M	84 - 85	•
ATC	200 S	84 - 86	•

**KYMCO**

	50 Agility	05 - 08	•
	50 Agility (4T) R10	06 - 14	•
	50 Agility (4T) R12	06 - 15	•
	50 Agility Basic	07 - 07	• •
	50 MXU	05 - 10	•
	125 Agility	06 - 11	•
	150 MXU	05 - 17	•

**MALAGUTI**

	50 Centro	93 - 96	•
	50 Yesterday	97 - 02	•
F-10	50	92 - 93	•
F-10	50 Jet-Line	94 - 98	•
F-12	50 Phantom	94 - 98	•
F-12	50 Phantom A.C.	99 - 03	•
F-15	50 Fire Fox	96 - 99	•
F-15	50 Fire Fox L.C.	96 - 08	•
SL	50 Centro	96 - 96	•

**PEUGEOT**

	e-Vivacity	11 - 15	•
	50 Elyseo		
	(A.J.P. cal.)	99 - 01	•
	50 Looxor	02 - 05	•
	50 Speedake		
	(A.J.P. cal)	94 - 01	•
	50 Speedake		
	(Brembo cal.)	94 - 01	•
	50 Speedake		
	(Hengtong cal.)	94 - 01	•
	50 Speedfight 3		
	(AC)	10 - 16	•
	50 Speedfight LC,		
	(A.J.P. cal.)	96 - 15	•
	50 Speedfight LC,		
	(Brembo cal.)	96 - 15	•
	50 Speedfight LC,		
	(Hengtong cal.)	96 - 15	•
	50 Trekker Road	99 - 00	•
	100 Elyseo		
	(A.J.P. cal.)	99 - 01	•

**SYM**

	50 Fiddle	09 - 14	•
	50 Jet, Alpha	95 - 97	•
	50 Jungle	96 - 02	•
	50 Mask	00 - 05	•
	50 Mask LC	00 - 05	•
	50 Red Devil	97 - 09	•
	50 Super Fancy	95 - 97	•
RS	50	05 - 09	•
	100 Super Fancy	95 - 00	•
	125 Attila	95 - 02	•
	150 Super Duke	96 - 01	•

**YAMAHA**

	50 Axis Pro Foot	92 - 99	•
--	------------------	---------	---





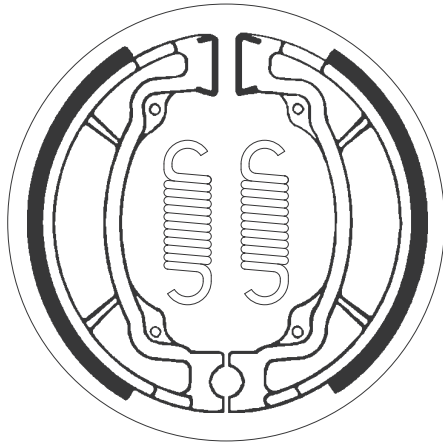

<b>HYOSUNG</b>			
	110 Midas Plus	98-04	•
FX	110 110	02-04	•
KR	110 Master	04-05	•

<b>KAWASAKI</b>			
AE	50	81-82	• •
AR	50	81-82	•
KD	80	80-87	• •
KD	80	88-90	•
KE	100	79-97	• •
KH	100	76-77	• •
KM	100	78-81	• •
KLF	110 Mojave	87-88	•
KLT	110	84-86	•
KLX	110	02-21	•
KLT	160	85-85	•
KLT	185	86-87	•
KLT	200	81-84	•
KLT	250	82-83	•
KLT	250 Police	84-84	•
KLT	250 Prairie	83-85	•

<b>SUZUKI</b>			
OR	50	79-79	• •
RM	50	78-80	• •
RM	80	77-79	• •
RV	90	73-81	• •
TS	90	71-73	•
RM	100	76-81	•



<b>SUZUKI</b>			
	110 Smash	03-06	• •
DR-Z	110	02-06	•
FX	110 Shogun	98-02	• •
TS	125	72-72	•

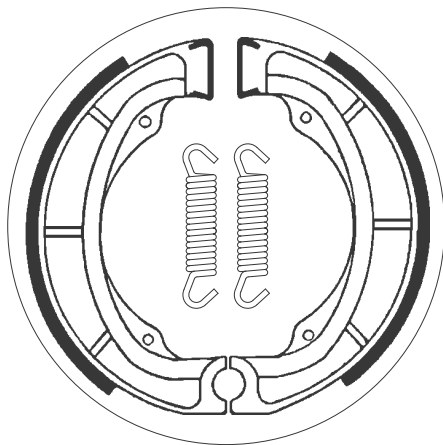

<b>KAWASAKI</b>			
KDX	250	80-82	•
KL	250	78-80	•
KX	250	75-81	•
KZ	250	80-83	•
KX	420	80-81	•

<b>SUZUKI</b>			
ALT	125	84-86	•
LT	125 E-H	84-87	•
LT	160	89-92	•
LT-F	160	91-04	•
ALT	185	85-87	•
LT	185	84-87	•
LT	230	85-86	•
LT-F	230	86-87	•
RM	250	76-78	•
RM	250	79-79	•
TS	250	74-82	• •
SP	370	77-79	• •
PE	400	79-81	• •
RM	400	78-78	•
RM	400	79-79	•
SP	400	80-82	• •



SUZUKI			
GSXR	50	87-87	•
LT-A	50 Quadmaster	01-05	•
LT-Z	50 QuadSport	06-20	•
OR	50 E	80-80	•
RM	50	81-82	• •
ZR	50	81-87	•
DS	80	80-96	• •
JR	80	01-07	• •
RM	80	80-81	• •
RM	80	83-85	•
LT-Z	90 QuadSport	07-14	•
DR	100	83-90	• •
DR-Z	125 K	03-12	• •
DR-Z	125 L	03-20	•

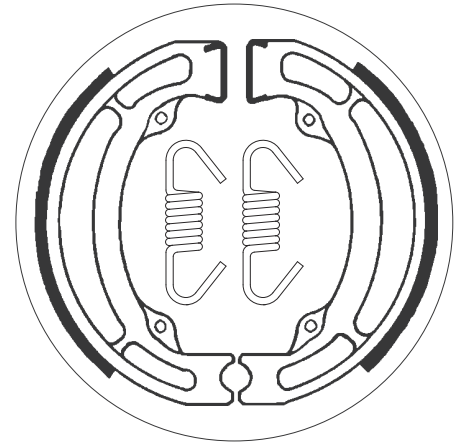

SUZUKI			
GS	250	80-82	•
GS	300	82-85	•
GN	400	80-80	•
LT-A	400 Eiger		
	2WD/4WD	02-07	•
LT-F	400 Eiger		
	2WD/4WD	02-07	•
GS	425	79-80	•
GS	450	80-83	•
GS	450	85-85	•
GR	650 X	83-84	•
LS	650 P	86-88	•
LS	650 P Savage	95-04	•
S40	650 Boulevard	05-18	•

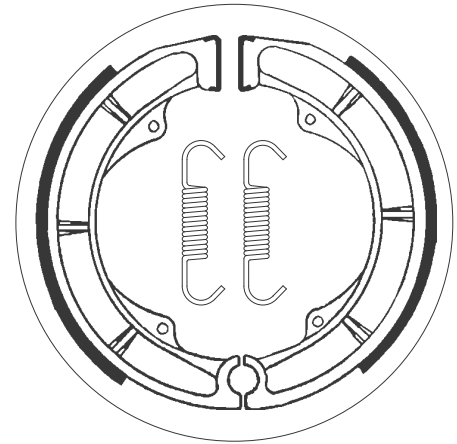

HONDA			
ATC	80	76-78	•
ATC	90 K1, K2, K3	73-78	•
TRX	90	93-01	•
ATC	110 all models	79-85	•
ATC	125 ME, MF, MG,		
	MH	84-87	•
TRX	125	85-88	•
CD	175 all models	71-78	•
ATC	185 A, S, SB	80-83	•
ATC	200	81-83	•
ATC	200 E Big Red	82-83	•
ATC	200 ES Big Red	84-84	•
ATC	200 M	84-85	•
ATC	200 S	84-86	•
TRX	200	84-84	•
TRX	200	90-91	•
TRX	200 D Type II	91-97	•



HONDA			
TRX	200 SX	86-88	•
ATC	250 ES, SX	85-87	•
FL	250 Odyssey	77-84	•

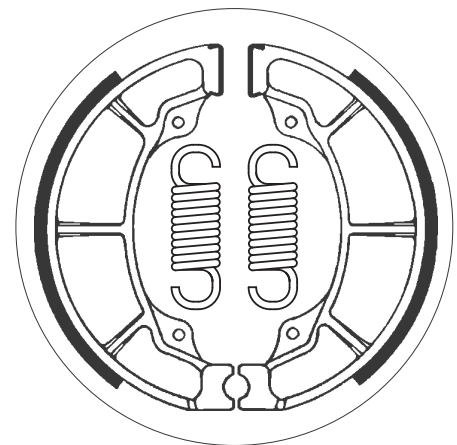





**HONDA**

CM	185 T	78-79	•
CM	200 TA, TB	80-82	•
CB	250 Nighthawk	91-02	•
CM	250 C	82-83	•
MT	250 K1	74-76	• •
XL	250	78-79	•
XL	250 S	78-81	•
XR	250	79-80	•
XL	350	76-78	•
XL	500 SZ	80-80	•

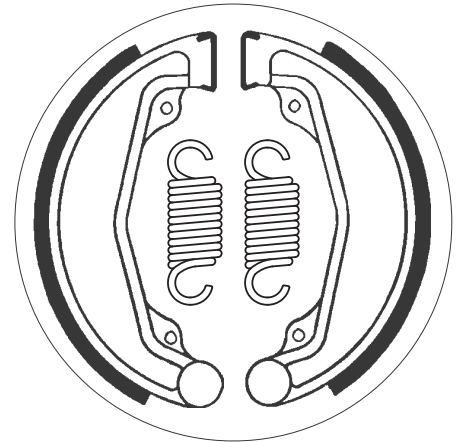

**HONDA**

ATC	250 ES, SX	85-87	•
TRX	250	85-87	•
TRX	300	88-00	•
TRX	300 4WD	88-00	•
CB	350 F, F1	73-76	•
CB	350 K4	74-74	•
CB	360 G, T	73-76	•
CB	400 F, F1, F2	75-79	•

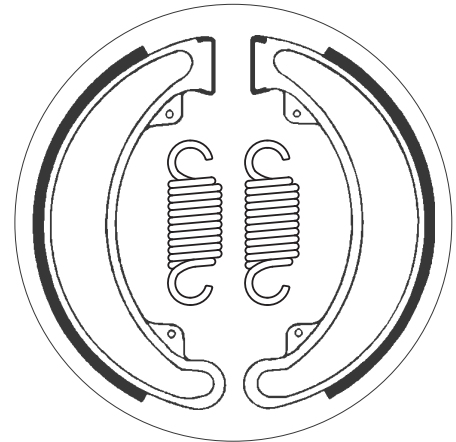

**KAWASAKI**

KX	125	83-85	•
KDX	200	83-85	•
KDX	200 C	86-88	•

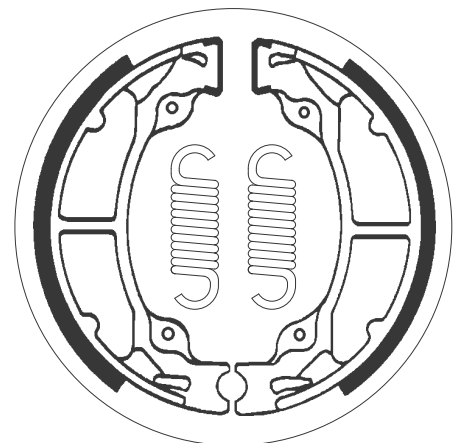

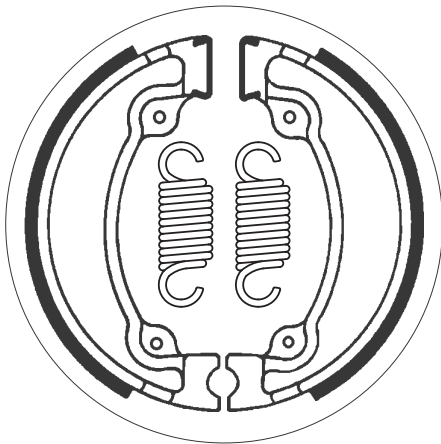

<b>CAGIVA</b>			
T4	350 R	87-99	•
T4	500 E	87-90	•
<b>HONDA</b>			
XL	250 S	81-81	•
XL	500 R	83-87	•
XL	500 RC	82-82	•
XL	500 SZ	80-80	•
XR	500 R Pro Link	81-82	•
XR	500 SZ, SA	79-80	•
XL	600 R	83-86	•
XL	600 V, Transalp	87-90	•

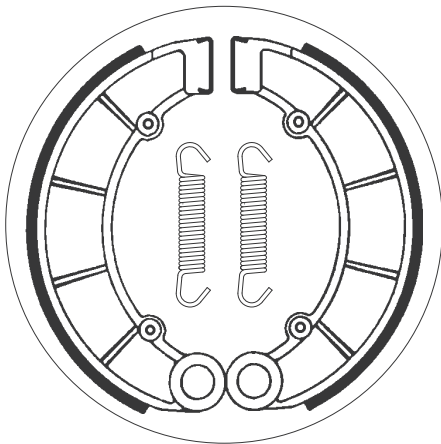

<b>HONDA</b>			
CB	650	79-81	•
CB	650 C	80-85	•
CB	650 SCC Nighthawk	82-82	•
CB	650 Z	78-81	•
CB	750 A	76-78	•
CB	750 C	80-84	•
CB	750 C, F, FII, K	85-86	•
CB	750 K Four	77-78	•
CB	750 K, L	79-80	•
CB	750 K0-K6 Four	70-76	•
CB	750 KZ	82-82	•
CB	750 PZ	81-84	•
CB	750 SC	82-83	•

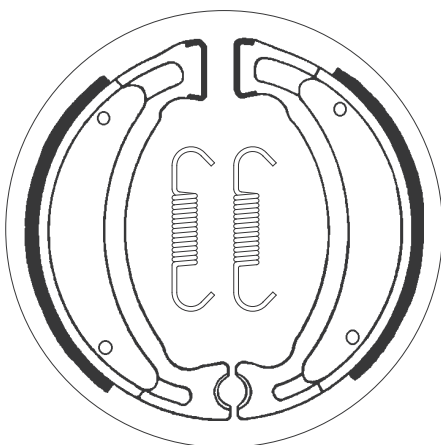

<b>ADLY</b>			
25	Silver Fox	00-05	•
50	Fox	00-09	•
50	Jet	96-99	•
50	Pista, Pista		
	Twin Light	96-99	•
50	Silver Fox	00-09	•
100	Jet	96-99	•
100	Silver Fox	06-06	•
<b>CPI</b>			
50	Baby	02-02	•
50	Hussar	01-06	•
50	Mars	01-02	•
50	Oliver	03-12	•
50	Oliver City	03-12	•
50	Oliver Sport	03-12	•
50	Popcorn	01-02	•

<b>DERBI</b>			
DXR	200 Quad		
	(Front drum)	04-05	•
DXR	250 Quad		
	(Front drum)	04-05	•
<b>KEEWAY</b>			
50	Flash	07-12	•
50	Flash Electric	10-12	•
50	Hurricane	06-16	•
50	Matrix	06-15	•
F-NKD	50	10-11	•
RY8	50	07-09	•
<b>POLARIS</b>			
250	Cyclone	87-87	•
350	Trail Boss 2x4	85-87	•













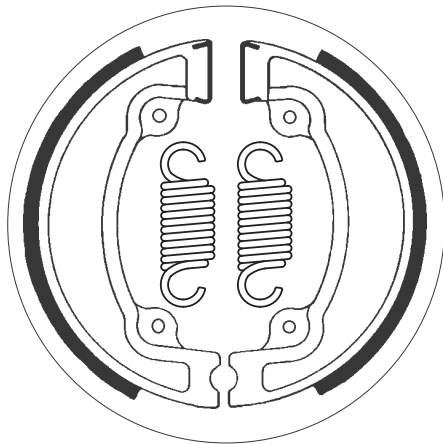

BOMBARDIER			
	50 Quest	03-04	•
DS	50	02-06	•
	90 Quest	03-04	•
DS	90	02-06	•
CAN-AM			
DS	50	07-11	•
DS	70	08-14	•
DS	90	07-18	•
HONDA			
TRX	70	86-87	•
CB	125 S	84-85	•
CR	125 R	79-81	•
CR	125 RC	82-82	•
CH	250 Elite	85-86	•
CH	250 Elite	87-90	•



HONDA			
CN	250	93-04	•
CR	250 R	81-82	•
XL	250 R	82-83	•
CR	480 R	82-82	•

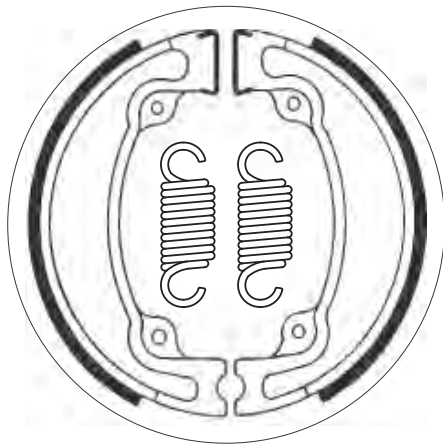

HONDA			
CR	125 RD	83-83	•
CR	125 RE, RF	84-85	•
CR	250 R	83-83	•
CR	250 RE, RF	84-85	•
XR	350 R	83-83	•
CR	480 R	83-83	•
CR	500 RE, RF	84-85	•

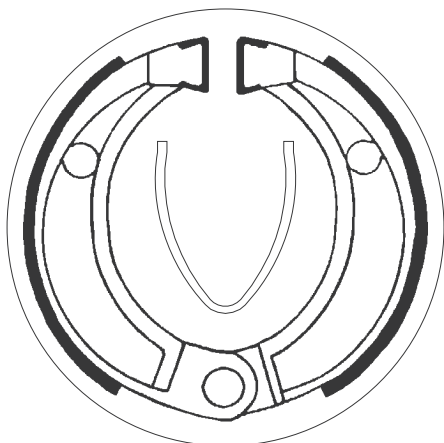

HONDA			
CR	80 R	86-91	•
CR	80 RF	85-85	•
POLARIS			
	90 Predator	03-14	•



ø130 x 25

SBS 2047

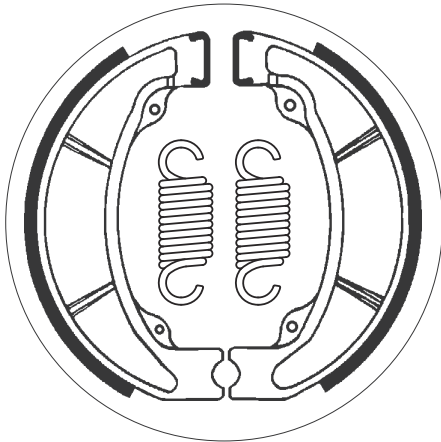

**HONDA**

CR	125 RG	86-86	•
CR	250 RG	86-86	•
CR	500 RG	86-86	•

ø87 x 20

SBS 2048

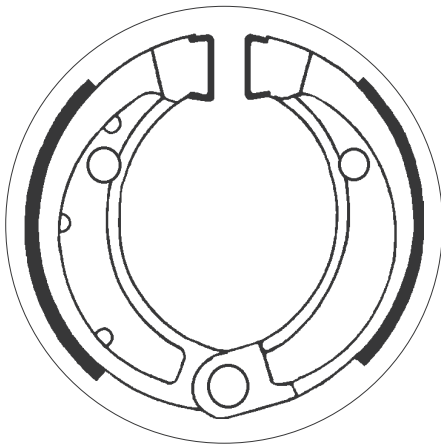

**ARCTIC CAT**

50	2WD	04-06	•
50	DVX	06-08	•
90	2WD	02-04	•
90	DVX	06-14	•

**BOMBARDIER**

50	Quest	03-04	•
DS	50	02-06	•
	90 Quest	03-04	•
DS	90	02-06	•

**CAN-AM**

DS	50	07-11	•
DS	70	08-14	•
DS	90	07-18	•

**HONDA**

TRX	70	86-87	•
-----	----	-------	---

**POLARIS**

50	Predator	04-14	•
50	Scrambler	01-03	•
90	Scrambler	01-03	•
90	Sportsman	01-15	•

ø130 x 22

SBS 2049

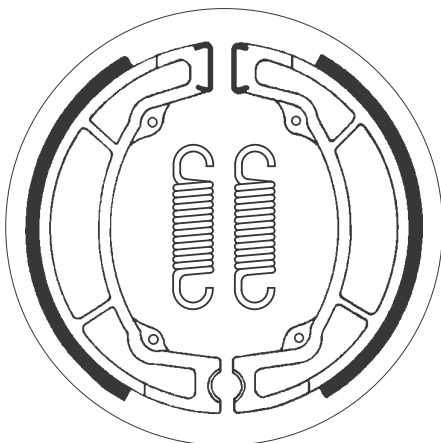

**YAMAHA**

YZ	125	83-87	•
IT	200	84-85	•
IT	200	86-86	•
TY	250	84-90	•
BW	350	87-88	•
TY	350	86-86	•



ø165 x 32

SBS 2053

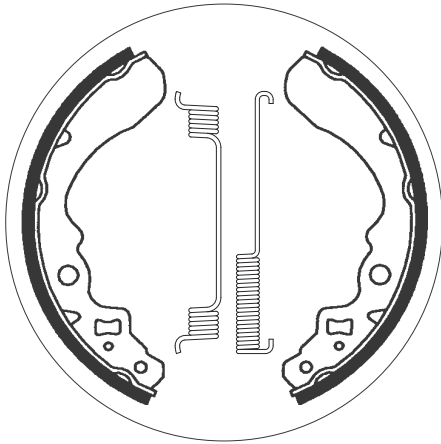

**KAWASAKI**

KAF	300 Mule 500	92-95	•
KAF	300 Mule 550	03-05	•

**SUZUKI**

LT	250 4WD	87-98	•
LT-F	250	88-01	•
LT-F	250 4WD V, W Quadrunner	97-98	•

ø160 x 30

SBS 2054

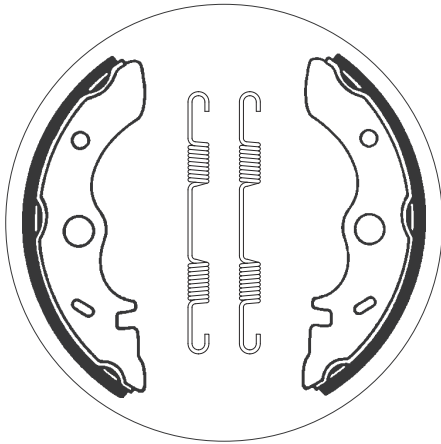

**KAWASAKI**

KLF	300 A1, A2 Bayou	86-87	•
-----	------------------	-------	---

ø140 x 30

SBS 2055

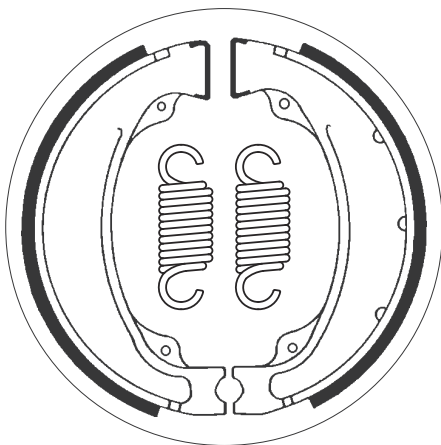

**HONDA**

TRX	250 EX Sportrax	01-08	•
TRX	250 Recon	97-21	•
TRX	250 X	08-13	•









ø140 x 30

SBS 2068

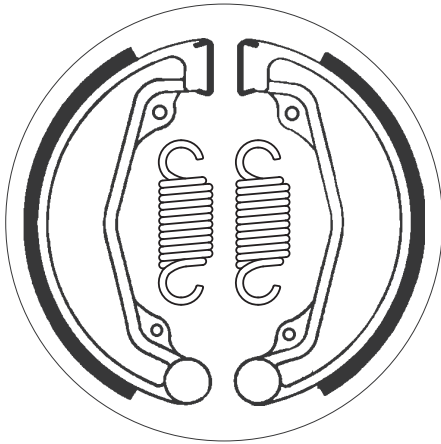

**HONDA**

CB	175 K3-K7	74-76	•
VTR	250	88-90	•
XL	500 SB	81-81	•

ø130 x 30

SBS 2069

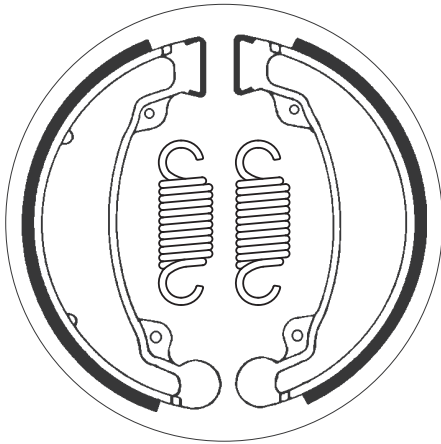

**HONDA**

ATC	70 all models	78-85	•
CM	185 T	78-79	•
CM	200 TA, TB	80-82	•
CB	250 Nighthawk	91-02	•
CM	250 C	82-83	•
CMX	250 C Rebel	96-00	•
CMX	250 Rebel	85-12	•

ø160 x 25

SBS 2070

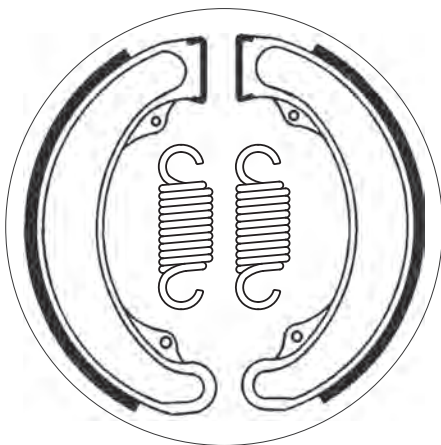

**HONDA**

XL	250	78-79	•
XL	350	76-78	•









**SBS 2093**

ø90 x 20



**KAWASAKI**

KX	60	83-03	•	•
KX	80	83-87		•
KLX	110	02-21	•	

**SUZUKI**

RM	60	03-03	•	•
DR-Z	110	02-06	•	

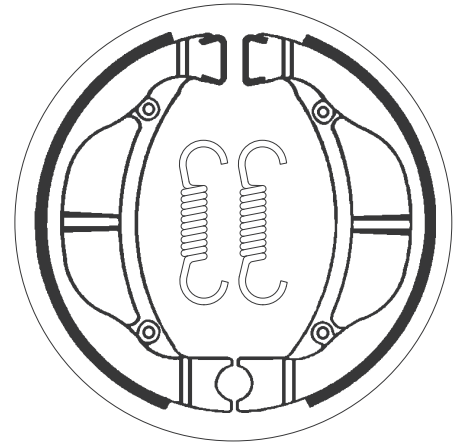

**SBS 2097**

ø180 x 28



**SUZUKI**

GT	250	73-78		•
GT	380	73-77		•
GT	380 Asco	77-77		•
GS	400	77-82		•

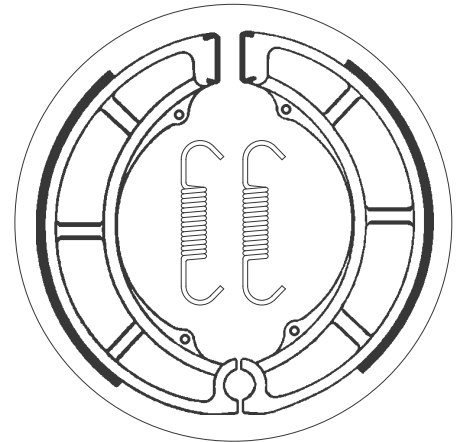

**SBS 2098**

ø180 x 40



**SUZUKI**

RE	5M, A	75-77		•
LT	250	85-86		•
LT-F	250 4WD V, W Quadrunner	97-98		•
LT	300	87-89		•
GT	500	73-77		•
GT	550	73-77		•
GT	750	73-77		•

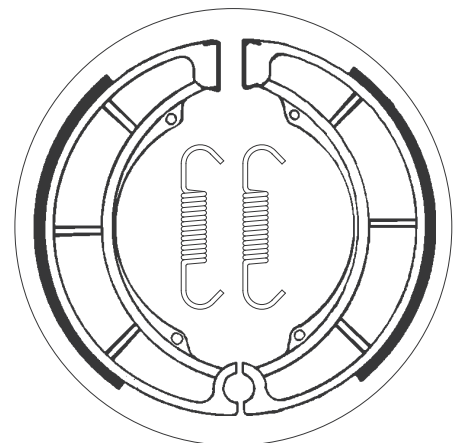











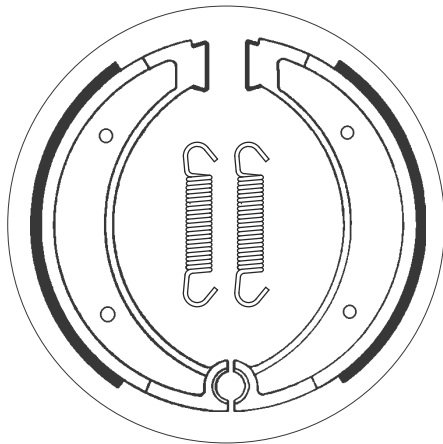

HUSQVARNA			
	all models	72 - 79	• •
	all models	87 - 88	•
	all models	TE,TC,WR,	
	CR,AE	89 - 89	•
CR	125	83 - 84	•
CR/RL	125	81 - 82	•
WR	125	80 - 80	•
XC	125	85 - 85	•
CR	250	81 - 84	•
WR/OR	250	80 - 80	•
WR/OR	390	80 - 80	•
WRX	400	85 - 85	•
	430 Enduro	85 - 88	•
CR	430	82 - 82	•
WR	430	87 - 89	•
CR	500	83 - 84	•



HUSQVARNA			
CX/CR	500	84 - 85	•

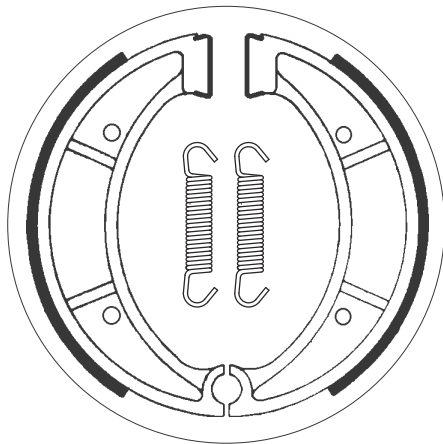

HUSQVARNA			
	all rear		
	drum		
	models	86 - 86	•
CR	125	85 - 90	•
CR/RL	125	81 - 82	•
WR	125	80 - 80	•
WR	125	85 - 90	•
WR/XC	125	82 - 82	•
WR/XC	125	83 - 84	•
CR	250	81 - 82	•
CR	250	85 - 87	•
WR/OR	250	80 - 80	•
WR/XC	250	81 - 82	•
WR/XC	250	83 - 84	•
WR/OR	390	80 - 80	•
WR/XC	390	82 - 82	•
	400 Enduro	85 - 88	•



HUSQVARNA			
WR	400	87 - 88	•
	430 Auto	87 - 87	•
CR	430	82 - 82	•
CR	430	87 - 89	•
CR/WR/CS	430	81 - 81	•
XC	430	87 - 88	•
CR	500	86 - 87	•
TC	500	86 - 86	•
WR/XC/AE	500	83 - 84	•
XC	500	87 - 88	•
	504	83 - 83	•
	510	87 - 89	•
TE	510	86 - 87	•

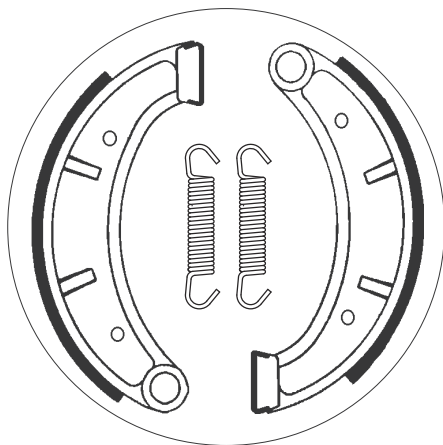

HUSQVARNA			
CR	125	83 - 84	•
WR/XC	125	83 - 84	•
CR	250	83 - 84	•
WR/XC	250	83 - 84	•
WRX	400	85 - 85	•
CR	500	83 - 84	•
WR/XC/AE	500	83 - 84	•

KTM			
	250 Cross	83 - 83	•
	500 Cross	82 - 82	•





**SBS 2143**

ø200 x 27



**BMW**

R80	800 R	93-94	•
R100	1000 R	92-95	•
R100	1000 RT	91-95	•

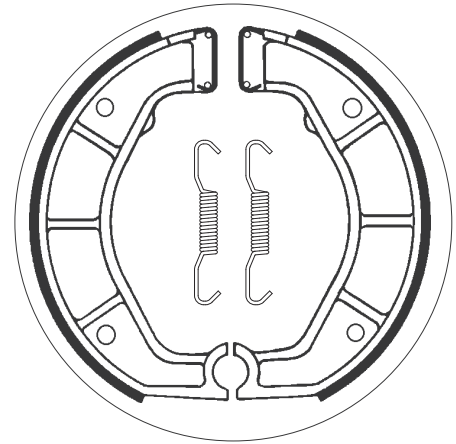

**SBS 2177**

ø170 x 27



**YAMAHA**

YFU1TW	250 Pro Hauler	89-89	•
YFU1W	250 Pro Hauler	89-90	•
YFP	350 U Terrapro	88-88	•



**SBS 2178**

ø160 x 25



**YAMAHA**

YFM	350 Big Bear Special Edition	99-99	•
YFM	350 FWH, FWJ, FWK Big Bear	96-98	•
YFM	350 FWW, FWA-G Big Bear	89-95	•
YFM	350 UH, UJ, UK	96-98	•
YFM	400 Kodiak	93-99	•

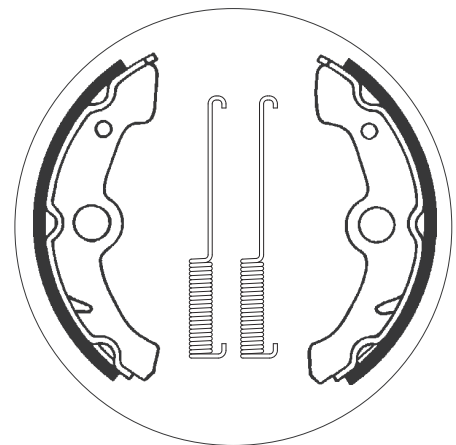

Dimensions in mm / Dimensions en mm  
1" = 25.4 mm , 1 mm = 0.04"



ø120 x 25

SBS 2181

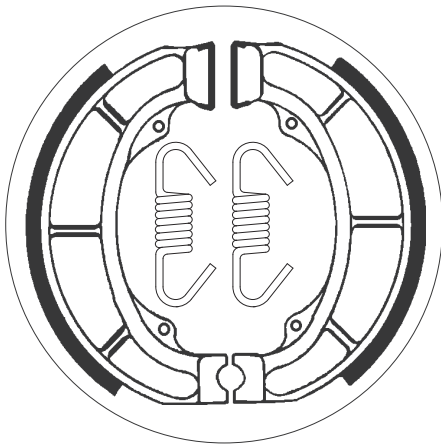

**DERBI**

50 Atlantis	99-08	•
50 Easy	96-98	•
50 Hunter	97-99	•
50 Manhattan	99-99	•
50 Vamos FL	95-99	•
50 Vamos L	95-95	•
ST 50 Paddock	96-99	•

**SUZUKI**

AH 50 Adress	92-95	•
ZZ 50 Scooter	92-92	•
AH 80 Adress, V, Tune	88-91	•
AH 80 Scooter	92-94	•
AH 100 V Adress	91-94	•
UK 110 Adress	15-19	•
LT 160	89-92	•
LT-F 160	91-04	•

ø95 x 20

SBS 2182

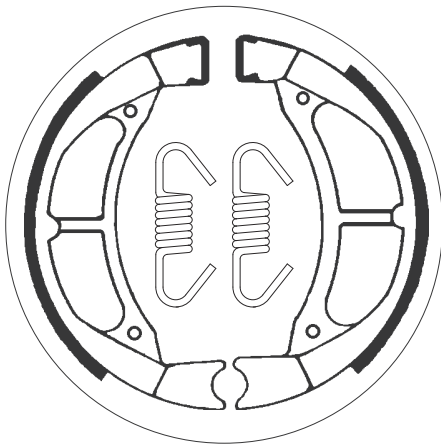

**SUZUKI**

RM 80	82-89	•
-------	-------	---

**YAMAHA**

YZ 50	80-83	•	•
YZ 60	85-85	•	•
BW 80	86-90	•	•
YZ 80	74-79	•	•
YZ 80	80-85	•	•
YZ 80	86-92	•	•
TT-R 90	00-10	•	•
TT-R 110	08-21	•	•

ø130 x 28

SBS 2183

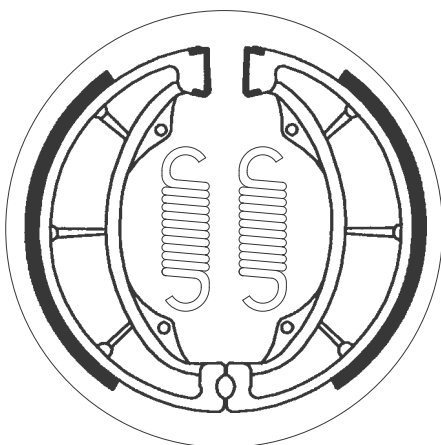

**KAWASAKI**

KLF 110 Mojave	87-88	•
KLT 110	84-86	•
KE 125	76-85	•
KX 125	74-82	•
KLT 160	85-85	•
KDX 175	80-82	•
KE 175	76-78	•
KLT 185	86-87	•
KDX 250	83-84	•
KLX 250	79-80	•
KT 250 all models	75-80	•
KX 250	82-85	•
KX 500	83-85	•
KL 600	84-86	•
KLR 600	84-86	•
KLR 600 E	85-94	•

Dimensions in mm / Dimensions en mm  
1" = 25.4 mm , 1 mm = 0.04"

**SBS 2188**

ø110 x 23



**SYM**

125 Husky	96-98	•
125 Super Duke	95-01	•
150 Husky	99-02	•

**TGB**

50 202T	99-02	•
---------	-------	---

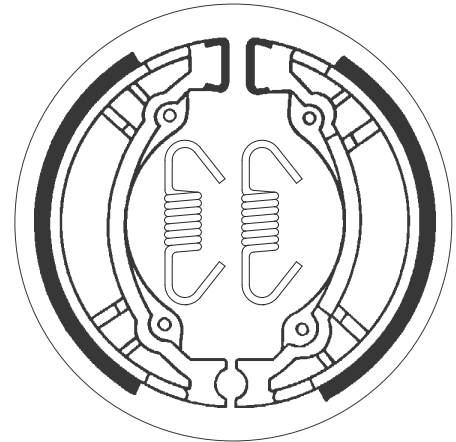

**SBS 2189**

ø130 x 25



**HONDA**

CN 250 Helix	86-87	•
--------------	-------	---

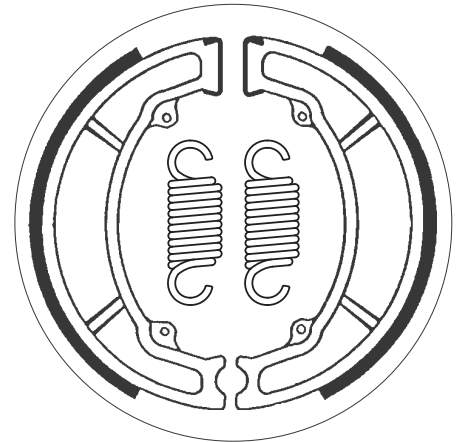

**SBS 2190**

ø200 x 25



**YAMAHA**

SR 500	92-98	•
--------	-------	---

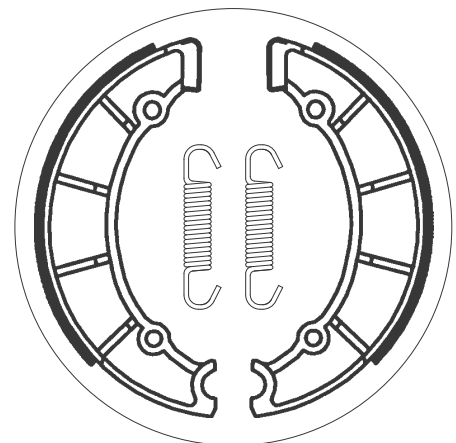







ALMOST ANY BIKE  
BRAKE PADS, CLUTCH KITS AND BRAKE ROTORS

Find the right part with  
the PRODUCT SELECTOR  
at SBSBRAKES.COM

**sbs**<sup>®</sup>  
GO AHEAD



HI-TECH BRAKE SOLUTIONS  
MADE IN EUROPE

Find the right brake pads, discs or clutches for your bike

Select the fields in any order

Brand\*  CC\*  Model\*  Year\*

SHOW MATCHES >

NEW SEARCH



@sbsbrakes | sbsbrakes.com | #GoAhead

# CROSSLIST

**BRAKE PADS**

**SAME SHAPE / DIFFERENT THICKNESS**

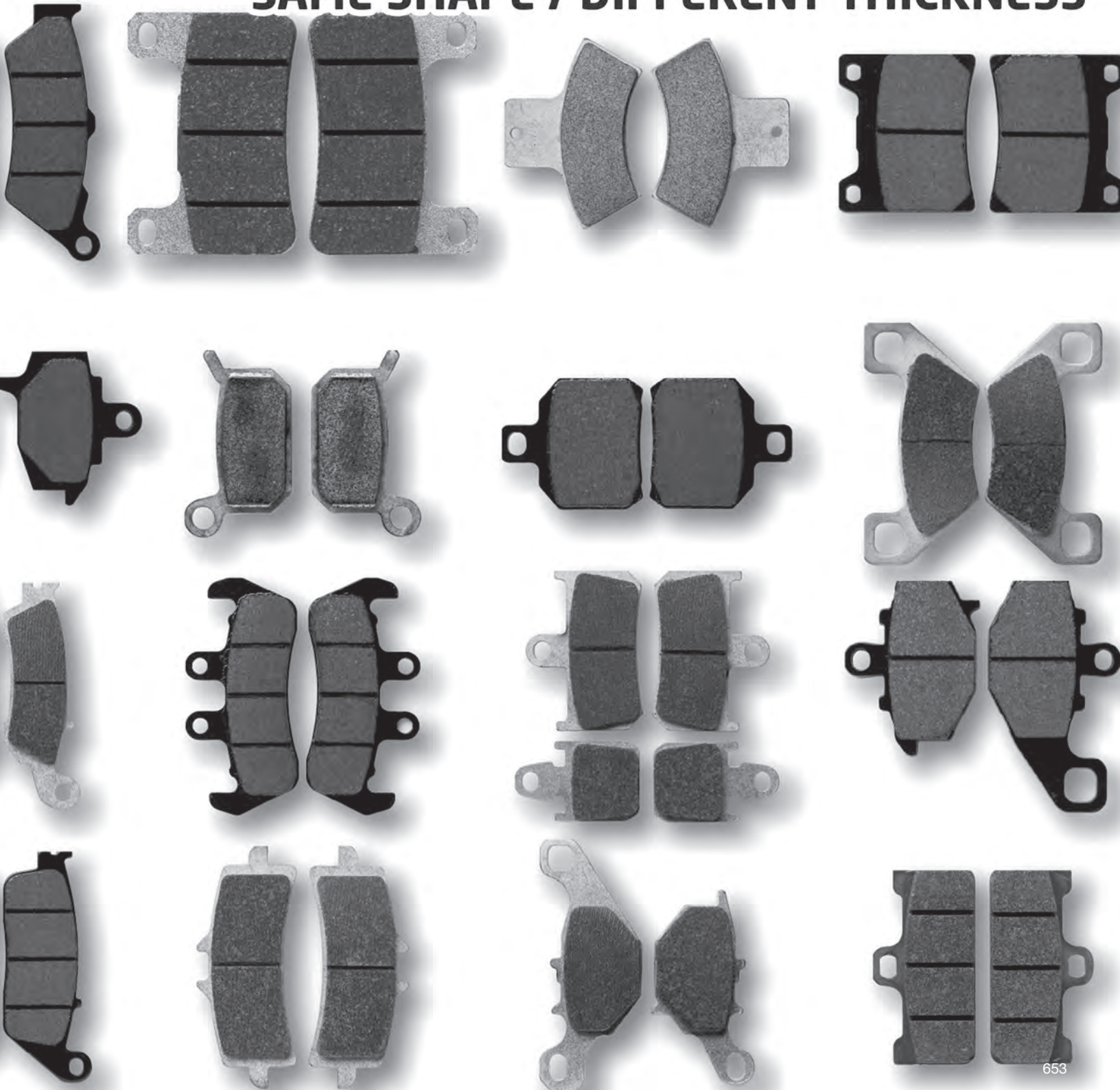

SBS Ref.	Total th.	SBS Ref.	Total th.	SBS Ref.	Total th.	SBS Ref.	Total th.	SBS Ref.	Total th.
103	7.0	200	7.5						
104	7.3	125	9.3						
115	8.0	209	5.3						
121	9.0	144	9.5						
119	9.2	134	8.0						
121	9.0	144	9.5						
123	6.3	143	7.0						
125	9.3	104	7.3						
127	9.0	160	11.0						
134	8.0	119	9.2						
142	6.9	202	6.2						
143	7.0	123	6.3						
144	9.5	121	9.0						
160	11.0	127	9.0						
163	9.2	197	8.0						
181	10.4	183	8.1	184	8.9				
183	8.1	184	8.9	181	10.4				
184	8.9	181	10.4	183	8.1				
197	8.0	163	9.2						
200	7.5	103	7.0						
202	6.2	142	6.9						
209	5.3	115	8.0						
216	7.0	222	9.0						
222	9.0	216	7.0						
223	9.0	236	7.0						
236	7.0	223	9.0						
508	12.0	517	9.5						
517	9.5	508	12.0						
523	10.4	698	7.0						
526	11.0	556	9.0						
539	8.0	540	9.5						
540	9.5	539	8.0						
542	11.0	572	9.0						
551	7.0	814	7.5						
552	8.0	571	9.5						
556	9.0	526	11.0						
558	7.3	709	9.3						
571	9.5	552	8.0						
572	9.0	542	11.0						
581	7.1	582	9.5						
582	9.5	581	7.1						
584	6.5	592	7.5						
590	10.5	613	8.8						
592	7.5	584	6.5						
599	8.0	661	9.0						
600	8.4	647	10.5						
611	8.0	713	9.2						
613	8.8	590	10.5						
614	10.7	881	9.0						
624	8.5	714	7.0						
627	8.1	700	9.6	654	10.4	630	9.6		
630	9.6	627	8.1	700	9.6	654	10.4		
631	8.1	789	13.0						
632	8.7	648	9.5						
638	8.0	688	9.2						
647	10.5	600	8.4						
648	9.5	632	8.7						
600	8.4	647	10.5						
654	10.4	630	9.6	627	8.1	700	9.6		
661	9.0	599	8.0						
662	11.0	678	8.0						
671	7.6	742	8.6/10.1	924	9.0				
676	8.2	729	10.0	779	12.0				
678	8.0	662	11.0						
688	9.2	638	8.0						
695	8.3	711	10.2						
698	7.0	523	10.4						
700	9.6	654	10.4	630	9.6	627	8.1		





# NEW! Get the brake feel you want!



Find the right brake pad compound for you and  
your bike with the new Compound Selector at  
[sbsbrakes.com](http://sbsbrakes.com)

Find the right compound for you and  
your bike

Click Start Now, answer 2-3 questions and get the answer right away

START NOW

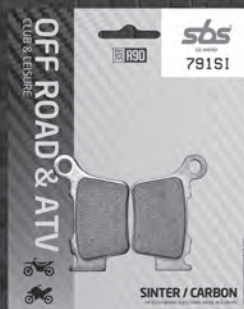

@sbsbrakes | [sbsbrakes.com](http://sbsbrakes.com)

HI-TECH BRAKE SOLUTIONS  
MADE IN EUROPE

# CROSSLIST

## OE - SBS

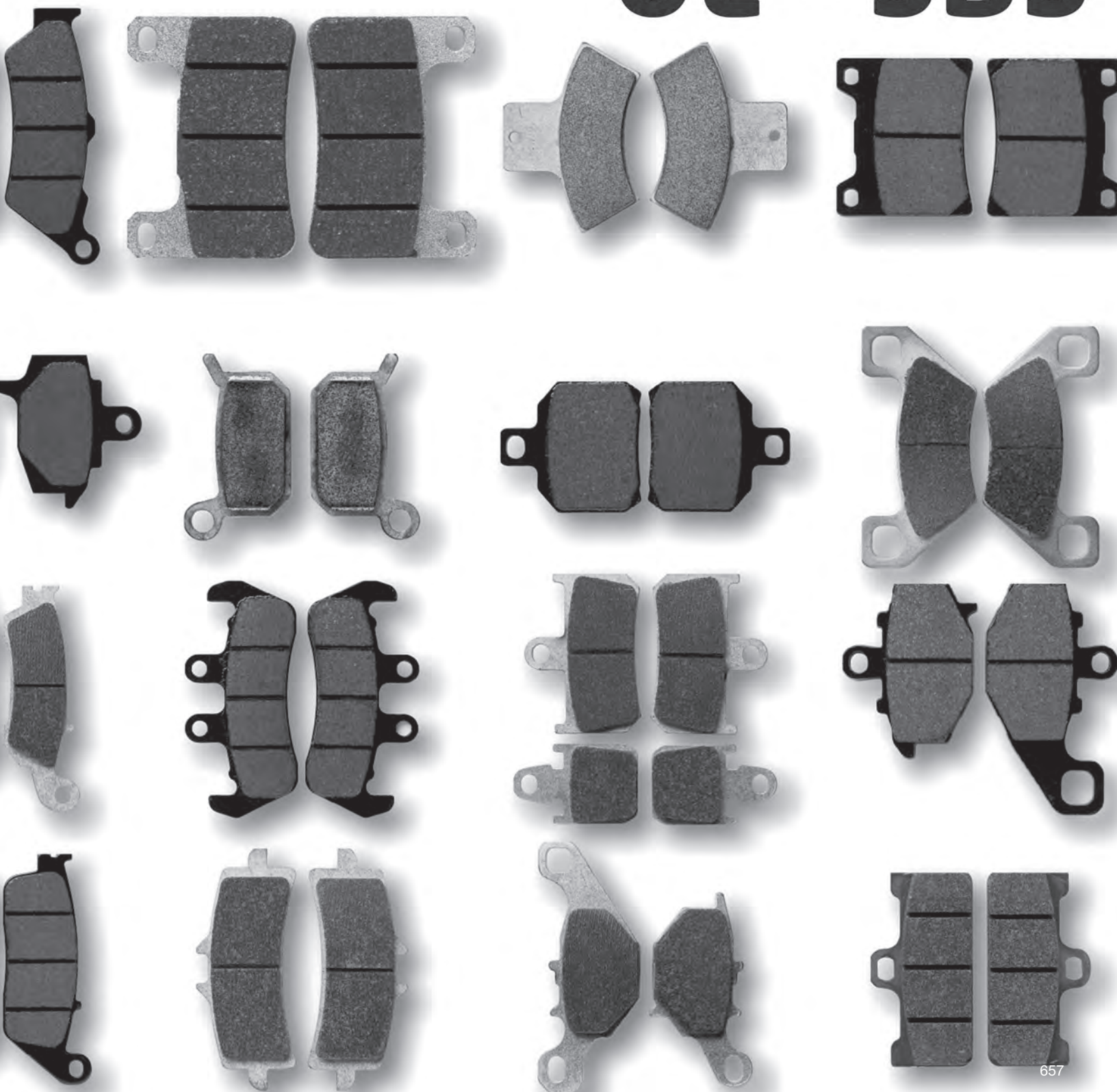

OE No.	SBS No.	OE No.	SBS No.	OE No.	SBS No.	OE No.	SBS No.
0/000-930-0090	585	06435-HA5-670	592	06451-HL3-A00	982	06455-MAS-305	622
0/000-930-7001	773	06435-HN8-006	813	06451-HL4-A01	981	06455-MAT-006	736
000016546300	706	06435-HN8-016	976	06451-HL6-A01	981	06455-MAT-E21	736
0000-365-46000	674	06435-HP1-006	813	06451-HPO-A01	829	06455-MAW-621	654
0000-640-7210	797	06435-HP5-602	592	06451-KZZ-901	859	06455-MAW-761	694
00009300060	559	06435-HP6-A01	829	06452-HL4-A01	981	06455-MAY-000	694
00009300065	652	06435-K01-D11	193	06452-HL6-A01	981	06455-MBB-006	622
00009300080	774	06435-K04-931	193	06452-HPO-A01	829	06455-MBE-006	627
00009308000	730	06435-K26-921	915	06455-371-405	517	06455-MBG-005	736
00025001198	546	06435-K40-F02	193	06455-425-405	526	06455-MBK-751	654
000276-546100	519	06435-K40-F11	193	06455-443-405	572	06455-MBR-006	676
000306546260	674	06435-KBS-W00	588	06455-6CK-006	604	06455-MBT-051	828
000306546300	641	06435-KCZ-000	604	06455-GAV-405	588	06455-MBT-611	736
000306546310	601	06435-KFK-006	614	06455-GBF-J01	592	06455-MBW-006	734
000316546650	519	06435-KFK-016	614	06455-GBZ-701	536	06455-MBW-E11	734
0009307001	559	06435-KPC-641	784	06455-GCC-B52	709	06455-MC5-R01	828
00157056	810	06435-KPC-643	784	06455-GCR-006	688	06455-MCA-006	736
00-1865-4660	506	06435-KPE-016	158	06455-GCS-006	709	06455-MCA-016	736
00276546100	519	06435-KPP-901	784	06455-GCS-016	709	06455-MCB-611	694
00-2865-4601	506	06435-KPP-902	784	06455-GCS-026	709	06455-MCC-006	736
00306546250	671	06435-KRN-711	777	06455-GFM-D31	205	06455-MCH-006	736
00736071800	895	06435-KRN-712	777	06455-GZ8-405	694	06455-MCK-A01	654
00D01210221	559	06435-KSV-J01	193	06455-HP1-006	694	06455-MCS-G01	736
00G01202221	773	06435-KSV-J02	193	06455-HP1-016	694	06455-MCS-G02	736
00G04700141	559	06435-KT7-405	614	06455-K01-D11	654	06455-MCS-R01	828
00H001201221	821	06435-KV3-405	657	06455-K40-F11	654	06455-MCT-691	736
00H01301931	559	06435-KW6-841	688	06455-KBR-731	694	06455-MCW-H01	828
00H01302551	773	06435-KYJ-901	881	06455-KCC-841	951	06455-MCZ-006	622
00H01303551	559	06435-KZ4-J41	777	06455-KCC-842	951	06455-MEA-671	654
00H01304931	773	06435-KZZ-901	915	06455-KCR-405	654	06455-MEH-006	828
00H04702-141	652	06435-MAJ-G41	736	06455-KCZ-000	694	06455-MEL-003	809
00H04703141	774	06435-MAT-006	736	06455-KEB-900	713	06455-MEL-013	809
00H047041-41	730	06435-MAZ-006	715	06455-KEH-900	536	06455-MEL-D22	809
00RTS01A0015	652	06435-MBL-D01	736	06455-KFG-016	722	06455-MET-651	828
00TRS01A0027	802	06435-MCC-006	736	06455-KFG-641	722	06455-MFA-D11	828
00TRS01-A0046	859	06435-MCE-006	715	06455-KFR-701	627	06455-MFA-D12	828
00TRS01A0068	585	06435-MCH-006	736	06455-KN8-405	572	06455-MFJ-D01	809
00TRS01-A0074	859	06435-MCS-G01	736	06455-KPB-406	722	06455-MFR-A01	828
00TRS01A0075	604	06435-MCS-G03	736	06455-KPB-416	722	06455-MGE-006	869
014360258000	774	06435-MCT-405	654	06455-KPC-641	688	06455-MGE-016	869
03613-9666	519	06435-MEE-006	657	06455-KPH-951	797	06455-MGP-081	841
0402-096	758	06435-MEJ-006	657	06455-KPM-006	558	06455-MGS-D31	654
0402-494	758	06435-MEJ-016	657	06455-KPN-E01	688	06455-MGS-D32	654
0402-882	758	06435-MEL-D21	834	06455-KPN-E02	688	06455-MGS-D81	828
0452883	546	06435-MEL-D22	834	06455-KPP-901	797	06455-MJE-D02	627
0453036	544	06435-MEL-D23	834	06455-KR3-000	688	06455-MJF-D02	809
0453200	546	06435-MFF-D01	614	06455-KR3-405	688	06455-MJM-D31	809
0453201	546	06435-MFG-D02	834	06455-KRM-861	536	06455-MJM-D41	947
0454293	544	06435-MFN-D01	862	06455-KSE-006	592	06455-MJP-G51	940
0454440	905	06435-MFN-D02	862	06455-KSE-016	592	06455-MKC-A01	952
0454444	906	06435-MFN-D11	862	06455-KSS-952	694	06455-MKF-061	841
0454664	905	06435-MFN-D12	862	06455-KSV-J01	828	06455-MKF-D41	947
047-00-2000036	566	06435-MGE-D01	892	06455-KSV-J03	828	06455-MKF-D61	841
04700-2000037	519	06435-MGE-D02	892	06455-KSV-J41	828	06455-MKH-D01	940
0502-019	758	06435-MGS-D31	881	06455-KTK-006	688	06455-MKR-D11	985
0502-604	822	06435-MGY-641	862	06455-KTW-901	828	06455-ML4-P00	593
0502-875	822	06435-MGZ-J01	881	06455-KW6-843	688	06455-ML7-P10	593
06 1894	505	06435-MJM-D01	862	06455-KW6-844	688	06455-MM5-P00	600
06 6005	505	06435-ML7-405	542	06455-KWF-951	797	06455-MR1-405	627
06 6186	505	06435-ML7-415	542	06455-KWN-641	205	06455-MS6-P00	647
0624	671	06435-ML7-P01	654	06455-KYJ-901	627	06455-MT8-405	647
0631	790	06435-MOZ-J01	881	06455-KZL-861	205	06455-MV4	647
06345-MGZ-J01	614	06435-MR7-P00	623	06455-MAB-405	654	06455-MW3-405	627
06431-HL6-A01	975	06435-MS2-P00	654	06455-MAH-405	654	06455-MY1-405	694
06431-MA3-405	859	06435-MS9-405	654	06455-MAJ-G41	736	06455-MY5-731	674
06435-761-405	517	06435-MT3-405	654	06455-MAK-000	674	06455-MY9-871	706
06435-GCM-900	129	06435-MT8-405	542	06455-MAK-003	674	06455-MZ0-760	627
06435-GCM-902	129	06435-MY9-405	614	06455-MAL-G01	627	06455-MZ1-405	622
06435-HA5-405	592	06435-MZO-006	654	06455-MAN-911	674	06455-MAA-405	654

OE No.	SBS No.	OE No.	SBS No.	OE No.	SBS No.	OE No.	SBS No.
06455-NX4-860	782	11967300	773	1J3-20000-13	507	2201398	642
06455-NX7-006	782	11967800	774	1J3-20000-63	507	2201399	755
06456-MAW-761	694	119-69800	713	1J3-20000-64	507	2201685	757
06456-MCA-006	736	11969900	575	1J3-20000-70	507	2201749	757
06456-MCB-611	694	11D-FS811-00	671	1J3-W0045-00	507	2201871	787
06456-MCB-612	694	11H-W0045-00	550	1J3-W0046-00	507	2202097	800
06456-MCC-006	736	11H-W0045-01	550	1J9-20000-02	507	2202411	755
06456-MCW-H01	828	11L-W0045-00	550	1KT-W0046-50	570	2202412	642
06456-MEH-006	828	11U-W0045-00	550	1KT-W0046-51	570	2202413	800
06456-MFF-D01	828	11U-W0045-10	550	1KT-W0046-52	570	2202414	787
07009R	566	12906040	519	1L9-W0045-00	507	2202491	674
07010R	607	1296006	519	1L9-W0046-00	507	2203045	822
0722189	843	1296007	656	1LN-W0045-01	580	2203318	898
072223	843	1296033	656	1LR-W0046-00	589	2203452	642
07-6708-21	706	13D-FS811-00	774	1LX-W0045-00	580	2203628	899
07-684831	695	140330	619	1NL-W0045-00	590	22037-47	897
07-7874-24	805	14140001000E	551	1NL-W0045-01	590	2203792	642
07-8354-24	845	1436-165	822	1P1-W0046-00	754	2203930	898
07-8366-30	889	1436-420	822	1PH-F5806-00	145	2204088	899
07849312/27	791	14654601	506	1RK-W0045-00	590	2205606	899
0784931V27	671	14654650	506	1RK-W0045-50	590	2205949	954
07881950	706	1502-694	822	1RK-W0046-00	590	2206025	970
078819RC	706	153-W0045-10	638	1S3-W0046-00	816	2207667	977
07883050	841	159-07-6340	588	1S4-W0045-00	688	2208161	978
0795-39-856	506	1677	774	1S6-W0045-00	654	22B-FS811-00	627
07-9882-10	841	1679	671	1S9-F530K-00	858	22U-W0045-10	550
07BB2010	730	1799-0078	739	1SC-F5806-00	546	238-070-5-6340	588
07BB2050	730	1799-0079	739	1SD-F5911-00	195	238-07-6340	541
07BB30RC	841	18654660	554	1SD-F5911-10	728	238-076570	574
09130-07E00	730	1910032	717	1U4-W0046-01	507	23W-W0045-01	547
0960-39-656	506	1910036	642	1U4-W0046-02	507	23W-W0045-10	547
0979-39-856	506	1910042	642	1UF-W0045-00	555	240-07-6340	541
ODN00G04700141	559	1910051	717	1UF-W0045-01	555	245-07-6340	574
102-33870	704	1910129	642	1UY-W0045-00	575	25.25362	790
107-28-86-30	519	1910333	642	1UY-W0045-01	575	251-0037-A	551
107-5365-13	519	1910339	755	1UY-W0045-02	575	252-0033A	688
107-6708-21	706	1910450V	757	1UY-W0045-03	575	2525230000	652
107670823	706	1910514	800	1UY-W0046-00	592	252524000	519
107-684830	711	1910683	787	1WD-25805-00	931	2525-242000	519
107-694-936	730	1911171	642	1WD-25806-00	932	2525250000	607
107-861750	671	1911197	898	1XD-25805-00-00	971	2525340000	774
107988210	841	1930626	717	1XD-25805-10-00	972	25-25352	802
107-A225-40	839	1930643	642	1XD-25806-00	638	2525352000	802
107-A486-02	695	1930644	717	1XD-25806-00-00	973	25-25363	896
107-A486-03	711	1930731	642	1XD-25806-10	611	2525371000	747
107-A486-04	805	1930741	717	1XD-25806-10-00	974	25-25373	896
107-A486-48	809	1930815	642	2020073-T0301	624	2547/F/S	519
107-A486-49	841	1930860	755	20S-W0046-00	614	2654F/S/R2	631
107-A486-51	806	19654600	519	211021021	566	266-07-6340	595
107-A486-53	566	1965-4600	519	211021022	519	26H-W0045-00	555
107-A486-55	864	19654601	519	211021038	675	26H-W0045-01	555
114100100000E	585	1A1-W0045-00	504	211041010	566	26H-W0045-10	555
1141-40001-100E	713	1B7-W0045-00	691	211082009	566	26H-W0045-11	555
114140003300A	773	1B7-W0046-00	185	211082010	519	26H-W0046-00	555
1160	773	1B9-W0045-00	194	211082018	706	26H-W0046-01	555
11933400	595	1C3-W0046-00	790	21330710000019	559	27-69173	566
119-363-00	607	1C3-W0046-B0	790	2133071-00003	559	28000214	900
11940100	684	1CO-25806-00	728	214-007-1000002	652	29-001	656
119-419-000	607	1D2-W0045-00	706	219800237	900	29L-W0045-00	550
119-468-000	607	1D4-F5742-00	773	2200418	717	29L-W0045-10	550
119-481-00	722	1D5-F5811-00	774	2200464	717	29L-W0046-01	555
11948600	747	1D7-25806-00	769	2200465	642	2C8-W0045-00	674
119-491-00	747	1D7-W0046-00	769	2200807	756	2CM-F-580500	223
119-493-00	774	1DK-W0045-00	627	2200899	717	2CM-F5805-10	222
119-495-00	774	1FK-W0045-00	555	2200901	642	2CO-25805-00	634
119-52200	519	1FK-W0045-10	555	2201093	755	2CR-25806-00	834
11955600	559	1FK-W0046-01	555	2201149	642	2DL-F5811-00	221
11955700	774	1FK-W0046-02	555	2201170	706	2DP-F580500	226
11966900	559	1J3-20000-11	507	2201189	755	2G2-W0045-00	528

OE No.	SBS No.	OE No.	SBS No.	OE No.	SBS No.	OE No.	SBS No.
2G2-W0045-01	545	34 11 2 314 546	640	38A-W0045-01	555	409-W0045-00	504
2G2-W0045-10	545	34 11 2 314 996	703	38W-W0045-00	575	41300053	715
2GH-W0045-00	590	34 11 2 331 173	703	38W-W0045-01	575	41300102	734
2GH-W0045-01	590	34 11 2 331 175	640	39P-W0045-00	634	41300161	671
2HC-25805-00-00	979	34 11 2 331 177	554	3B4-W0045-00	850	41300169	674
2HC-25806-00-00	980	34 11 2 333 045	703	3B4-W0045-10	849	41300197	949
2HF-W0046-00	589	34 11 2 345 445	674	3B4-W0046-10	851	413610	585
2HF-W0046-02	589	34 11 7 651 958	674	3BN-W0045-00	575	414220	878
2HH-W0045-00	580	34 11 7 655 687	703	3BN-W0045-01	575	41852-08B	830
2HH-W0045-01	580	34 11 7 658 156	703	3C1-F5805-10	858	42029-07	808
2HR-W0045-00	576	34 11 7 660 340	674	3C1-W0045-10	858	42298-08	854
2J2-W0046-00	507	34 11 7 660 448	796	3CL-W0046-00	659	42385-94Y	692
2J2-W0046-01	507	34 11 7 663 764	703	3CS-25805-00	728	42385-98Y	614
2KJ-W0045-00	550	34 11 7 671 780	796	3CS-W0045-00	728	42386-84Y	658
2M0-W0046-00	507	34 11 7 683 064	796	3D6-F5811-00	773	42386-984	676
2M0-W0046-01	507	34 11 7 696 593	706	3D7-W0045-10	627	4252	885
2MP-W0045-00	858	34 11 7 697 086	674	3D8-25806-00	769	42739-008	734
2NA-W0045-01	619	34 11 7 705 216	674	3EN-W0045-00	590	42831-04	807
2R8-W0045-003	528	34 11 7 711 498	706	3FV-W0045-00	624	42836-04	808
2UJ-W0045-00	550	34 11 7 717 292	671	3FY-W0045-00	575	42850-06	830
2UJ-W0045-01	550	34 11 7 717 308	671	3G1-W0046-00	507	43020-CEK-000	638
2VN-W0046-00	575	34 11 7 728 945	778	3GD-W0045-00	536	43020-S020	657
2VN-W0046-01	575	34 11 710 743	841	3GM-W0045-00	645	43050-001	503
2VW-F0047-00	608	34 11 8 405 104	960	3GM-W0045-01	645	43050-002	503
2XJ-25811-00	637	34 11 8 534 183	796	3GM-W0045-11	645	43050-005	510
305128A-003103	713	34 11 8 535 158	900	3GM-W0045-50	665	43050-006	510
306-25811-00	504	34 11 8 540 956	900	3H5-W0045-00	507	43050-007	510
306-25811-01	504	34 11 8 548 028	900	3H5-W0045-01	507	43050-008	510
306-25811-02	504	34 21 1 236 221	506	3H6-W0045-00	528	43050-009	510
306-25811-03	504	34 21 1 542 313	984	3HE-W0045-00	555	43050-010	512
306-25811-04	504	34 21 2 314 997	742	3HE-W0045-11	555	43050-011	510
306-25811-05	504	34 21 2 330 633	742	3J6-W0045-01	528	43050-1006	514
306-25811-06	504	34 21 2 332 988	506	3J6-W0045-10	545	43050-1007-A	522
310-292	560	34 21 2 333 337	746	3J6-W0045-11	545	43050-1007-B	522
31A-W0046-00	555	34 21 2 335 465	742	3JB-W0045-00	616	43050-1008	514
31A-W0046-10	555	34 21 7 657 025	506	3JD-W0045-00	611	43050-1009	516
32176F	848	34 21 7 657 492	746	3JD-W0045-10	638	43050-1010	516
32176G	848	34 21 7 660 281	742	3JD-W0046-00	584	43050-1013	512
3220505A	914	34 21 7 671 246	746	3JD-W0046-01	584	43050-1021	510
322050A	914	34 21 7 680 374	746	3JD-W0046-10	584	43050-1040	544
323-627	519	34 21 7 680 375	746	3JH-W0045-00	575	43050-1043	544
326-446	519	34 21 7 717 324	791	3LC-25811-00	624	43050-1044	544
326-478	574	34 21 7 724 609	674	3LC-25811-50	659	43050-1048	544
326-814	588	34 21 8 534 821	674	3LC-W0046-00	659	43050-1051	544
32D-W0045-00	694	34 21 8 554 424	674	3LD-W0045-10	688	43050-1063	546
3303-446	749	34 21 8 556 442	742	3LD-W0045-30	688	43050-1064	546
3303-908	810	34 21 8 562 163	674	3LD-W0046-01	633	43050-1073	546
3304-567	749	34 71 2 301 359	527	3MA-W0045-00	634	43050-1082	546
3305-139	749	3406-031	592	3MW-W0045-00	624	43050-1126	544
3380925	559	3406-032	592	3P6-W0046-50	769	43050-1169	544
3380928	559	3406-075	649	3SH-F5811-00	684	43050-5001	510
33M-W0045-01	555	341-170	519	3SH-F5811-20	519	43050-5002	514
33M-W0045-10	555	341878	608	3SP-W0045-00	611	43050-5003	510
34 1 2 301 360	506	344839	588	3SP-W0046-00	648	43050-5004	522
34 11 1 233 319	520	344-840	575	3TC-W0045-00	624	43051-001	503
34 11 1 238 083	527	3499074	559	3TJ-W0045-00	634	43051-006	510
34 11 1 354 720	554	34L-W0045-10	550	3TJ-W0046-00	570	43051-007	510
34 11 1 451 995	506	34X-W0046-00	575	3UH-W0045-00	575	43051-008	510
34 11 1 454 724	506	34X-W0046-01	575	3UN-W0045-00	589	43051-009	514
34 11 1 458 388	506	34X-W0046-02	575	3XF-W0045-00	555	43051-011	510
34 11 1 542 307	985	3500000	878	3XG-W0045-00	619	43063-83	579
34 11 2 301 358	520	359-1-40-280-0	532	3XL-W0045-00	550	43071-001	503
34 11 2 310 494	640	359-1-40-283-1	532	3XP-W0045-00	611	43082-0002	782
34 11 2 310 601	554	36H-W0046-01	555	3YR-W0045-00	728	43082-0004	687
34 11 2 310 983	703	3710	671	3YX-W0045-00	663	43082-0006	790
34 11 2 310494	684	3711	791	4084	544	43082-0009	705
34 11 2 311 175	640	37A-W0045-00	555	4084-43D-F5906-00	544	43082-001	503
34 11 2 314 512	703	37P-F5811-00	654	409-25811-00	504	43082-0010	704
34 11 2 314 545	554	37P-W0046-00	728	409-25811-01	504	43082-0015	886

OE No.	SBS No.	OE No.	SBS No.	OE No.	SBS No.	OE No.	SBS No.
43082-0016	631	43082-1028	536	43082-1147	615	43082-1280	704
43082-0042	752	43082-1029	557	43082-1148	687	43082-1282	705
43082-0043	536	430821031	546	43082-1151	632	43082-1283	704
43082-0048	790	43082-1031	557	43082-1152	694	43082-1286	694
43082-0049	694	43082-1051	546	43082-1157	687	43082-1288	631
43082-0052	886	43082-1056	546	43082-1160	687	43082-1290	782
43082-0055	715	43082-1057	557	43082-1161	597	43082-1291	556
43082-0060	713	43082-1058	530	43082-1162	615	43082-1292	604
43082-0063	886	43082-1059	512	43082-1163	546	43082-5006	592
43082-0069	638	43082-1061	557	43082-1164	544	43082-5010	604
43082-0073	657	43082-1062	557	43082-1167	557	43082-5012	604
43082-0078	798	43082-1063	546	43082-1169	631	43082-S001	702
43082-0079	627	43082-1064	546	43082-1171	687	43082-S005	702
43082-0080	638	43082-1065	544	43082-1172	694	43082-S007	649
43082-0081	688	43082-1066	592	43082-1173	604	43082-S009	694
43082-0082	611	43082-1067	591	43082-1177	705	43082-S011	694
43082-0087	611	43082-1068	597	43082-1178	704	43082-S015	702
43082-0090	604	43082-1069	597	43082-1179	686	43082-S018	704
43082-0091	806	43082-1070	546	43082-1180	556	43082-S019	705
43082-0099	611	43082-1072	602	43082-1181	676	43082-Y001	749
43082-0100	611	43082-1073	546	43082-1182	715	43082-Y003	810
43082-0105	886	43082-1074	597	43082-1187	705	43082-Y004	810
43082-0107-855852	790	43082-1075	615	43082-1188	704	43082-Y005	627
43082-0111	687	43082-1076	615	43082-1189	597	43082-Y006	204
43082-0113	806	43082-1077	597	43082-1191	546	43082-Y007	627
43082-0115	834	43082-1078	602	43082-1193	694	43082-Y008	204
43082-0116	886	43082-1079	544	43082-1194	557	430-82-Y008	204
43082-0117	614	43082-1080	557	43082-1196	726	43-09-11	560
43082-0119	687	43082-1081	544	43082-1199	686	43105-1EE8-305	810
43082-0123	704	43082-1082	592	43082-120	546	43105-461-305	508
43082-0124	886	43082-1083	544	43082-1200	556	43105-461-770	517
43082-0126	638	43082-1084	546	43082-1201	536	43105-461-771	508
43082-0128	688	43082-1085	615	43082-1203	704	43105-461-772	508
43082-0129	782	43082-1086	546	43082-1204	546	43105-ARB-000A	142
43082-0131	734	43082-1087	615	43082-1205	592	43105-GT4-004A	604
43082-0132	694	43082-1088	597	43082-1206	726	43105-GW2-004A	604
43082-0134	216	43082-1089	611	43082-1208	631	43105-HB9-008	558
43082-0138	638	43082-1090	632	43082-1213	687	43105-HE0-305	610
43082-0140	810	43082-1092	546	43082-1218	694	43105-HMA-00DA	847
43082-0144	806	43082-1093	611	43082-1223	705	43105-KBF-3050-MZ	129
43082-0146	611	43082-1094	638	43082-1224	686	43105-KBF-9000	129
43082-0147	806	43082-1095	597	43082-1226	704	43105-KK9-691	598
43082-0150	627	43082-1096	546	43082-1227	686	43105-KN8-007	572
43082-0152	722	43082-1097	631	43082-1228	604	43105-KS6-701A	604
43082-0153	631	43082-1098	556	43082-1230	686	43105-KS6-702A	604
43082-0155	657	43082-1101	615	43082-1232	704	43105-KT7-761A	614
43082-0157	841	43082-1102	631	43082-1234	705	43105-KT7-762A	614
43082-0158	730	43082-1103	556	43082-1235	704	43105-KV3-831	614
43082-0162	841	43082-1104	597	43082-1238	688	43105-KZ1-405	604
43082-0166	657	43082-1110	631	43082-124	694	43105-LBA2-305	212
43082-0167	687	43082-1111	631	43082-1241	536	43105-LDH1-E00	195
43082-0168	782	43082-1113	631	43082-1242	752	43105-LDH-1E00	847
43082-0169	722	43082-1114	597	43082-1243	704	43105-LEA7-305	204
43082-0171	841	43082-1115	544	43082-1244	705	43105-LFC4-305	688
43082-0172	688	43082-1117	611	43082-1246	704	43105-LGE5-305	195
43082-0173	627	43082-1118	632	43082-1248	704	43105-LKF-305	212
43082-0179	713	43082-1120	631	43082-1250	686	43105-MB4-007/017	542
43082-039	886	43082-1123	597	43082-1251	686	43105-MB4-008	542
43082-1001	510	43082-1124	597	43082-1253	686	43105-MB4-305	542
43082-1003	556	43082-1125	615	43082-1255	801	43105-MB6-018/008	542
43082-1004	530	43082-1127	615	43082-1257	556	43105-MG9-007/017	542
43082-1005	510	43082-1129	611	43082-1259	686	43105-MJ6-721/722/723	572
43082-1007	539	43082-1131	632	43082-1260	704	43105-MJ6-724	572
43082-1008	539	43082-1134	597	43082-1265	704	43105-ML7-006	542
43082-1021	539	43082-1137	632	43082-1266	694	43105-ML7-007	542
43082-1022	539	43082-1139	597	43082-1267	604	43105-ML7-017	542
43082-1025	539	43082-1141	556	43082-1272	686	43105-ML7-027	542
43082-1026	539	43082-1142	631	43082-1273	798	43105-ML7-921A	654
43082-1027	546	43082-1144	615	43082-1274	686	43105-ML7-922A	654

OE No.	SBS No.	OE No.	SBS No.	OE No.	SBS No.	OE No.	SBS No.
43105-MN5-008	542	43211-431-673	509	45105-425-006	526	45105-KR3-004	551
43105-MN8-006	614	43235-FYBQ-300	536	45105-443-761	572	45105-KR3-007	551
43105-MR7-007A	623	43251-KTW-901	193	45105-443-762	572	45105-KR3-014	551
43105-MR7-017A	623	43395-80	543	45105-471-006	526	45105-KR3-601	551
43105-MS2-007A	654	43957-80	553	45105-961-000	592	45105-KR3-602	551
43105-MS9-612A	654	43957-80A	553	45105-961-006	562	45105-KR3-603	551
43105-MT3/6-007	654	43957-86	668	45105-ACL1-305	945	45105-KR3-871	688
43105-MT4-007A	654	43957-86A	668	45105-APA000A	708	45105-KS3-901	588
43105-MT7-405	623	43957-86B	668	45105-BA5-RB10M1	654	45105-KS3-902	588
43105-MT8-008	542	43957-86D	668	45105-BM9-741	618	45105-KS5-004	558
43105-MW0-405	657	43957-86E	668	45105-BM9-742	618	45105-KS5-006	558
43105-MWO-425	657	43D-F5906-01	546	45105-BM9-743	618	45105-KS6-831A	603
43105-MY1-405	614	43F-W0045-00	550	45105-DE3-A00	688	45105-KT7-751	593
43105-MY6-415	604	43F-W0045-01	550	45105-G02-000-AS	708	45105-KT7-761	593
43105-MY7-405	654	44005-74	513	45105-G04-601	558	45105-KT8-004	593
43105-NF5-611	618	44005-78	513	45105-G22-000-AC	708	45105-KTO-405	694
43105-NF5-612	618	44032-77	537	45105-GBF-405	536	45105-KV0-701	647
43105-NN2-600	519	44032-79	537	45105-GC4-601	536	45105-KV6-701	694
43105-NN3-820	803	44063-83A	579	45105-GC4-602/603	536	45105-KW3-405	603
43105-NN3-830	803	44063-83B	579	45105-GE2-004	551	45105-KW3-681	603
43105-SABA-Z00M1	688	44063-83C	579	45105-GE2-006	551	45105-KW6-405	688
43105-SZ2-0000	847	44063-83E	579	45105-GE2-305	551	45105-KW7-405	551
43105-SZ2-0010	847	44082-00	826	45105-GE3-601	536	45105-KY4-901	588
43105-VM0-008	610	44082-00C	826	45105-GE3-602	536	45105-KY4-902	588
43105-VM0-771	610	44135-74	513	45105-GH9-710	618	45105-KY7-008	603
43106-961-006	592	44135-78	513	45105-GM9-743A	618	45105-KZ1-405	603
43106-GT4-004B	604	44203-115-0000	816	45105-GW6-004	536	45105-KZI-405	694
43106-GW2-004B	604	44203-OSB-0000	536	45105-H13-000-AC	708	45105-LB17-3050	810
43106-KS6-701B	604	44209-82	549	45105-H3A-900A	792	45105-LBA2-305	627
43106-KS6-702B	604	44209-82A	549	45105-H7C-700A	749	45105-LBA7-3050	810
43106-KT7-761B	614	44209-87B	669	45105-HA2-671	558	45105-LCA7-305	627
43106-KT7-762B	614	44209-87C	669	45105-H-A3-A-000	792	45105-LDC8-305	713
43106-KV3-831	614	44213-87	669	45105-HA5-671A	603	45105-LDCS-305	749
43106-ML7-921B	654	44281-74	679	45105-HA5-672A	603	45105-LEA-010A	708
43106-MN8-006	614	44442-00	826	45105-HA5-672B	603	45105-LEA1-306	713
43106-MR7-007B	623	44603-0580000	767	45105-HB9-008	558	45105-LEA7-305	627
43106-MR7-017B	623	44666-/-4477	707	45105-HHA-000A	708	45105-LEE-8305	810
43106-SABA-Z00M1	688	45102-393-700	501	45105-KA3-731	558	45105-LEJ2-305	749
43108-H3C-000A	688	45105-006/016/026	572	45105-KAS-415	694	45-105-LFC3-305	546
43108-HMA-000A	663	45105-166-007	536	45105-KAZ-004	627	45105-LFE9-305	945
43108-HWW-000A	847	45105-300-040	502	45105-KB9-960	588	45105-LGE5-305	159
4310A-BA4-000M1	688	45105-323-006	501	45105-KBE-3050-M2	688	45105-LKF-305	844
4312016900B	544	45105-323-013	501	45105-KBS-405	588	45105-LLJ3-305	627
43120-214-00-AEON	906	45105-323-016	501	45105-KCE-3050-M2	713	45105-MA5-671	526
43120-256-000	848	45105-323-023	501	45105-KE1-742	558	45105-MA5-771	561
43120-965-000	562	45105-323-036	501	45105-KE1-743	558	45105-MA5-772	561
43120-HA5-305	592	45105-323-043	501	45105-KE1-744	558	45105-MC7-004	572
43120-HA5-670	592	45105-341-000	502	45105-KECE-305M2	713	45105-MC7-007	572
43120-HC0-007	562	45105-341-003	502	45105-KED9-305	654	45105-MC7-014	572
43121-205-001-AEON	905	45105-341-305	502	45105-KFA6-305	749	45105-MC7-024	572
43150-KBE-3060	688	45105-371-000	517	45105-KFA6-3050	749	45105-MC9-305	561
43150-LDHIE-00	688	45105-390-003	501	45105-KK4-004	551	45105-MF9-306	558
43150-LEA5-306	688	45105-390-006	501	45105-KK4-007	551	45105-ML0-007	593
43150-LLS-3050	688	45105-390-305	501	45105-KK4-014	551	45105-ML4-000	593
431A0-431-673	509	45105-410-004	508	45105-KKD-6305	713	45105-ML4-004	593
431A0-965-000	562	45105-410-006	508	45105-KL8-004	572	45105-ML4-006	593
431A0-965-670	562	45105-410-007	508	45105-KL8-007	572	45105-ML4-008	593
431A0-HA5-670	592	45105-410-016	508	45105-KL8-014	572	45105-ML4-014	593
431A0-HB9-008	558	45105-410-026	508	45105-KL8-712	572	45105-ML4-024	593
431A0-HEO-670	610	45105-410-305	508	45105-KM1-004	558	45105-ML7-006	600
431-A0-MC7-024	572	45105-413-003	526	45105-KM1-007	558	45105-ML7-007	600
431A0-MN5-670	542	45105-413-305	526	45105-KM1-710	558	45105-ML7-017	593
431A0-MT4-670	654	45105-413-871	526	45105-KM1-711	558	45105-ML7-405	627
431A0-VM0-008	610	45105-415-004	508	45105-KM1-712	558	45105-ML7-921/922	627
43211-371-006	509	45105-415-006	508	45105-KN8-007	572	45105-ML7-P10	627
43211-392-006	509	45105-415-305	508	45105-KN8-712	572	45105-MM5-007	600
43211-392-016	509	45105-415-770	508	45105-KR1-861	588	45105-MM5-008	600
43211-431-671	509	45105-415-772	508	45105-KR1-862	588	45105-MM5-017	600
43211-431-672	509	45105-425-003	526	45105-KR1-863	588	45105-MM9-670	572



OE No.	SBS No.	OE No.	SBS No.	OE No.	SBS No.	OE No.	SBS No.
45105-MM9-781	572	45110-B20T000	544	470-13-090-200	783	4SV-W0045-00	634
45105-MM9-782	572	45110-HB7-007	592	470-13090-300	872	4SV-W0045-50	555
45105-MN4-008	593	45110-J00-P001	585	4716630	691	4TP-W0045-00	611
45105-MN4-008	593	45110-JHFT-000	544	4722090	773	4TR-W0045-00	663
45105-MN5-008	647	45110-K2GP-000	713	4730480	728	4TW-W0046-00	659
45105-MN5-018	647	45110P180000	983	4741-537	523	4US-W0045-00	728
45105-MN8-006	622	45110-T80-0000	961	47X-W0045-00	555	4W1-W0045-00	547
45105-MN9-008	647	45112-GC4-601	592	47X-W0045-01	555	4W1-W0045-20	547
45105-MR1-671	647	45112-GC4-831	592	48-7100-7	575	4W1-W0045-30	547
45105-MR7-006	622	451-13-030-000	794	491-13-409-044	519	4W1-W0046-00	528
45105-MR7-612	622	45113-REA-300A	810	494097	142	4W5-W0045-00	545
45105-MR7-681	622	4511A-RAI-000	810	494628	774	4WM-W0045-00	663
45105-MS6-901	647	45120-107-000	619	494966	730	4WM-W0046-00	590
45105-MS8-008	647	45120-119-00	544	497002	772	4WV-W0045-00	592
45105-MS9-612	627	45120-128-000	585	497072	177	4X8-W0045-00	550
45105-MT2-007	647	45120-1-68000	544	497083	730	4XV-W0045-00	634
45105-MT2-008	647	45120-1-69000	544	497116	177	4XV-W0046-00	733
45105-MT4-651/405	627	45120-211-000	546	497348	772	4XV-W0046-10	733
45105-MT8-008	647	45120-256-000	810	497395	187	50-005	678
45105-MV4-008	627	45120-580-000	706	497396	671	503-13-030-000	671
45105-MW0-405	622	45120-J80-000	933	497417	548	503-13-030-100	671
45105-MW0-415	622	45120-T40-0000	688	497429	191	510	506
45105-MY6-405	694	45120T-580000	713	498840	607	510-015-4-282	559
45105-MY6-415	694	45130-L4A300	893	498846	142	510-362-4-282	595
45105-N02-001-A	150	45130T40-000	713	4AJ-W0045-00	559	513506	546
45105-NF4-000	600	45135-L4A300	893	4AP-W0046-00	570	514069	544
45105-NN2-900	559	45150-KEG8-3050	713	4B5-W0045-00	634	515049	810
45-105-NN3-830	802	45150-LLB5-3050	688	4BP-W0045-00	663	515050	810
45105-NN4-K20	939	451A0-HB5-670	592	4C8-W0045-00	839	5190-080256	551
45105-NX7-006	782	451A0-HB9-670	603	4C9-W0045-00	858	51L-W0046-00	570
45105-PWA-305	810	451A0-KA3-731	558	4D3-W0045-00	850	51L-W0046-01	570
45105-PWB-1305	822	451A0-KR3-603	551	4D3-W0045-10	849	51L-W0046-02	570
45105-SB3-0001M1	713	451A0-MG3-670	558	4DA-W0046-00	648	52R-W0045-00	550
45105-SEA0000	688	451A0-MM8-670	542	4EB-W0045-00	691	52S-F5811-00	208
45105-TFA-000-A	129	451A0-MN4-670	593	4ES-W0045-00	589	53182-ABE1-9000	566
45106-300-004	502	451A0-MT2-670	647	4ES-W0046-00	584	54074--10000	536
45106-323-013	501	451A0-MT4-670	627	4EW-W0045-00	611	545-13209-044	546
45106-323-016	501	451A0-MT8-670	647	4EW-W0045-01	611	546-13-209-044	671
45106-323-023	501	451A0-ML7-670	600	4FM-W0045-00	683	546-13-309-200	675
45106-323-036	501	45340-107-720-A	525	4FM-W0045-10	683	546-13-309-300	675
45106-323-043	501	45340-107-721-A	525	4FM-W0045-20	555	546-13-309-400	675
45106-341-000	502	45340-107-722-A	525	4FM-W0045-30	555	548-13-090-000	791
45106-341-003	502	45340-149-000-A	525	4FM-W0046-00	555	548-13-090-100	791
45106-341-305	502	45340-149-003-A	525	4FU-W0045-00	663	548-13-090-300	791
45106-390-003	501	45340-149-720-A	525	4GA-W0045-00	691	55100-23044-08	536
45106-390-006	501	45340-950-000-A	525	4GV-F5911-00	671	55120315	627
45106-390-305	501	45345-107-720-B	525	4GV-FS811-00	648	55120P-300000	730
45106-BA5-RB10M1	654	45345-107-721-B	525	4GY-W0046-00	648	55W-W0045-00	596
45106-HA5-671B	603	45345-107-722-B	525	4H7-W0045-00	545	55W-W0045-01	596
45106-HA5-672B	603	45345-149-000-B	525	4H7-W0045-10	545	560584	713
45106-KR3-871	688	45345-149-003-B	525	4H7-W0045-12	545	56325-R	671
45106-KS6-701A	603	45345-149-720-B	525	4HM-W0045-00	691	565-13209323	621
45106-KS6-701B	603	45345-950-000-B	525	4HM-W0045-50	706	565-13209544	621
45106-KS6-831B	603	45350-107-720	525	4JG-W0045-00	728	56A-W0046-00	580
45106-KV3-701	622	45350-107-720-B	525	4K0-W0045-00	507	573-V3-030-000	566
45106-KV6-701	694	45350-950-000	525	4K0-W0045-01	507	585925/A	674
45106-KW3-681	603	45802-115-0000	816	4K0-W0045-02	507	587-13-030-000	706
45106-KY7-008	603	45815-NAF00	544	4KG-W0045-00	590	59100-01820	597
45106-ML7-922	627	45815RAM00/01	544	4KG-W045-10	706	59100-02820	544
45106-ML7-922B	627	45815-RAM-000	546	4KL-F5811-00	575	59100-02821	544
45106-MN8-67-1B	654	45815-RAM-01	546	4KM-W0045-00	663	59100-02830	544
451-06-MR4-901	627	460-13-016-000	559	4L3-W0045-00	547	59100-03860	706
45106-MS9-612	627	460-13-090-000	574	4L3-W0045-10	547	59100-05820	688
45106-MS9-612B	654	46113030-000	783	4MX-W0045-00	611	59100-05830	713
45106-MT4-651/405	627	462-13-030-000	783	4NK-W0045-00	590	59100-06820	577
45106-MW3-671	654	464143	595	4NK-W0046-00	590	59100-07810	688
45106-SB3-0001M1	713	46630-FYBQ-000	551	4P1-W0045-00	589	59100-09840	611
45106-SEA0000	688	470-13-030-000	885	4S5-W0045-00	858	59100-09850	611
4510A-KW6-9000	688	470-13-090-000	783	4SU-F5811-00	566	59100-09860	638

OE No.	SBS No.	OE No.	SBS No.	OE No.	SBS No.	OE No.	SBS No.
59100-09870	611	59101-35810	631	59300-20830	702	59301-33870	686
59100-09880	638	59101-38810	536	59300-20841	702	59301-36810	694
59100-09890	611	59101-38820	536	59300-20880	702	59301-39810	546
59100-10810	577	59101-38850	536	59300-21820	627	59301-39811	546
59100-11850	515	59101-38860	536	59300-21840	627	59301-39812	546
59100-14830	841	59102-33810	704	59300-21850	627	59301-39841	585
59100-14850	841	59102-33840	704	59300-22830	828	59301-45810	533
59100-14860	841	59102-33870	704	59300-24830	581	59301-45811	533
59100-16820	556	59103-33810	704	59300-26820	546	59301-45850	533
59100-18840	503	59130-00810	577	59300-26830	611	59301-45860	597
59100-18841	503	59130-00A00	577	59300-27810	611	59301-48811	627
59100-19820	620	59130-00A10	577	59300-27830	611	59301-HP7-600	713
59100-20810	577	59130-06B10	577	59300-27850	611	59302-20820	548
59100-20820	577	59130-06B20	577	59300-27860	611	59302-22850	705
59100-21860	627	59130-06C00	631	59300-29820	585	59302-33810	705
59100-21870	627	59130-16700	556	59300-29860	694	59302-33830	705
59100-21890	688	59130-16720	556	59300-33810	546	59302-33850	705
59100-22810	631	59130-16730	556	59300-33850	705	59302-39870	524
59100-22830	828	59130-16740	556	59300-33870	686	59302-45810	597
59100-23830	782	59130-16750	556	59300-33890	686	59302-45830	511
59100-23840	782	59130-16810	556	59300-34830	631	59303-33810	705
59100-24810	620	59130-17C00	624	59300-36810	546	59312-HP7-600	633
59100-26810	597	59130-19C00	620	59300-36811	546	59330-38300	533
59100-29820	806	59130-20C00	620	59300-36820	546	59330-38310	533
59100-29840	806	59130-22D00	631	59300-36821	546	59330-39100	524
59100-29850	806	59130-24A00	577	59300-36822	546	59330-46F00	544
59100-29860	806	59130-24A10	620	59300-36840	503	59330-H99-700	734
59100-30810	577	591-30-26820	546	59300-36850	694	59340-13A00	536
59100-30820	577	59130-26D00	620	59300-36860	694	59340-14500	582
59100-31830	503	59130-27A00	577	59300-36870	694	59340-14501	582
59100-31831	503	59130-27A10	577	59300-36871	546	59340-14510	582
59100-31850	836	59130-30B00	577	59300-37810	548	59340-14600	581
59100-31860	835	59130-30B01	577	59300-39820	524	59340-22A00	536
59100-32820	631	59130-30B10	556	59300-39821	524	59340-24B00	581
59100-33810	546	59130-30B20	556	59300-3K880	694	59340-24B10	581
59100-33812	546	59130-30B21	577	59300-42810	536	59340-39100	524
59100-33820	546	59130-32000	631	59300-42850	592	59340-42A10	536
59100-33830	624	59130-32020	631	59300-42860	592	59340-44A00	536
59100-33850	704	59130-32C00	631	59300-42870	592	59340-46F00	544
59100-33870	704	59130-32C10	631	59300-44810	511	59400-HP7-600	633
59100-34820	515	59130-32C20	631	59300-44820	511	59401-HP7-600	633
59100-34830	631	59130-33C00	624	59300-44821	511	59401-HP7-600	713
59100-34880	951	59130-33C10	624	59300-44822	511	594-13-030-000	843
59100-35830	631	59130-38C00	631	59300-44850	626	5943082-0123	704
59100-35850	631	59130-40C00	624	59300-44860	511	59C-25806-00	169
59100-35880	631	59130-45230	533	59300-44870	536	5AP-W0045-00	627
59100-36830/1	503	59130-45C10	620	59300-45820	515	5AU-W0045-10	663
59100-38820	577	59130-46E00	686	59300-45890	511	5B4-W0045-00	638
59100-38870	536	59130-48B00	620	59300-45891	511	5B4-W0045-10	611
59100-38880	536	59300-03840	591	59300-46810	516	5BK-F-5811-00	607
59100-39810	503	59300-03860	544	59300-46811	516	5BN-W0045-00	663
59100-39850	611	59300-03870	544	59300-46820	516	5CG-W0046-00	728
59100-40810	624	59300-03880	702	59300-46840/830	686	5CG-W0046-20	728
59100-40830	686	59300-03891	702	59300-47810	515	5CH-F5911-00	671
59100-43810	591	59300-04830	546	59300-47820	515	5CP-W0045-00	619
59100-45820	511	59300-04831	546	59300-47830	515	5D7-F5805-00	844
59100-45821	511	59300-05810	533	59300-47840	515	5D7-F5911-00	810
59100-45860	597	59300-06E00	559	59300-47850	515	5D7-FS811-00	671
59100-46820	686	59300-08810	611	59300-47870	515	5D9-W0045-01	858
59100-47890	806	59300-09810	544	59300-47880	515	5DH-W0045-00	694
59101-03810	828	59300-09811	544	59300-49820	534	5DH-W0045-10	694
59101-03820	828	59300-09840	638	59300-49821	534	5DH-WD0046-00	604
59101-09810	702	59300-09850	638	59300-49850	534	5DS-F5811-00	671
59101-14870	841	59300-13830	694	59300-HG5-800	551	5EB-W0046-00	728
59101-26820	627	59300-13860	694	59301-03820	726	5EK-W0045-10	728
59101-33810	704	59300-14830	582	59301-33810	546	5ET-W0046-00	604
59101-33820	704	59300-17810	624	59301-33820	705	5GF-W0045-00	611
59101-33830	704	59300-17811	624	59301-33830	705	5GF-W0046-00	648
59101-33850	704	59300-18810	503	59301-33840	705	5GH-W0046-00	754

OE No.	SBS No.	OE No.	SBS No.	OE No.	SBS No.	OE No.	SBS No.
5GH-W0046-10	754	613-13-030-000	841	69100-03890	754	69101-45830	512
5GJ-W0046-00	169	61313090000	730	69100-04830	614	69101-45840	512
5GM-W0046-00	728	61321161A	671	69100-05830	556	69101-45850-XNA	512
5HH-W0045-00	713	613-4-004-1-A	566	69100-05860	556	69101-45860-XNA	512
5HH-W0045-10	688	613-4-004-24	566	69100-05870	556	69102-05890	182
5JJ-W0045-00	634	6134005-1A	559	69100-06810	556	69107	671
5JU-W0045-00	619	613-4007-71A	519	69100-06820	657	69116	671
5JW-W0046-00	769	613-4008-1A	519	69100-06830	657	69130-16700	556
5KE-W0045-00	782	613-4-009-1A	566	69100-07810	649	69130-16740	556
5KM-W0046-00	799	61340121A	900	69100-08850	657	69130-20A10	556
5KN-W0045-00	165	613-4-0201-A	706	69100-08860	657	69130-21820	556
5LB-W0045-00	728	613-4-021-1A	730	69100-0BE00	556	69130-21E00	556
5LP-W0045-00	536	613-4-0211-B	706	69100-10820	789	69130-26D00	620
5LP-W0046-00	592	61340-281A	519	69100-10840	182	69130-27A10	556
5LP-W0046-50	592	61340-311A	519	69100-10860	182	69130-30B21	556
5LV-W0046-50	770	613-403-81A	730	69100-12810	635	69130-31E00	701
5MV-W0045-00	694	613-4-038-1A	730	69100-14860	174	69130-33C00	556
5MV-W0046-00	604	613-4-0411-A	706	69100-14890	174	69130-34220	512
5NR-F5811-00	671	613-4-0541A	519	69100-15810	632	69130-34240	512
5NR-F5811-10	730	61340721A	671	69100-15830	833	69130-34C00	556
5NW-W0045-00	190	6134-072-1A	671	69100-15850	833	69130-38820	577
5PA-W0045-00	589	61340731A	519	69100-16851	657	69130-38B00	577
5PA-W0046-00	584	61340751A	674	69100-16852	657	69130-38B10	577
5PS-W0046-00	769	61340791A	841	69100-18810	715	69130-45000	512
5PW-W0046-50	728	61340901A	841	69100-20810	556	69130-45001	512
5R2-W0045-00	550	61340941A	674	69100-21820	556	69130-45010	512
5RM-W0045-10	611	61340951A	730	69100-22820	615	69130-45020	512
5RU-W0045-00	691	61340961A	841	69100-22830	615	69130-45021	512
5RU-W0046-00	185	61341021A	900	69100-22850	615	69130-45030	512
5S7-10045-00	663	61341101A	841	69100-26810	620	69130-45100	512
5S7-25805-00	663	61341231A	841	69100-28820	790	69130-45101	512
5S9-W0045-00	208	61654630	506	69100-29810	715	69130-45990	512
5SE-F5811-00	671	6211	802	69100-31820	633	69130-45C00	620
5SE-F5811-10	671	639-41-054	699	69100-31830	701	69130-45C10	620
5SL-25805-00	634	64098800	619	69100-34860	556	69130-48810	577
5SL-W0045-00	634	647073	142	69100-34870	512	69130-48B00	577
5SL-W0046-00	657	647074	671	6910034890	915	69130-49F00	730
5SU-W0045-00	206	647077	730	69100-35810	790	69140-03D00	632
5SU-W0045-02	206	647078	177	69100-36820	604	69140-05D00	648
5TG-W0046-10	709	647079	187	69100-36830	604	69140-15D00	632
5UG-W0045-00	767	647080	191	69100-36840	604	69140-19A00	592
5UG-W0046-00	816	647157	142	69100-36850	604	69140-19A01	592
5UN-W0046-00	790	647161	772	69100-36860	604	69140-19A10	592
5UN-W0046-50	790	647170	142	69100-36870	604	69140-19A11	592
5UN-W0046-51	790	647171	548	69100-37810	604	69140-26C00	584
5V6-W0045-00	576	647400	191	69100-37830	604	69140-27C10	648
5V6-W0045-01	576	650983	177	69100-38810	577	69140-27C20	648
5VK-W0045-00	674	651253	177	69100-38820	577	69140-28C00	632
5VK-W0046-00	675	651356	142	69100-38840	577	69140-35B00	649
5VN-W0045-00	634	665621	142	69100-38860	577	69140-43840	648
5VU-W0046-01	185	665842	187	69100-38870	577	69140-43B00	649
5VX-25806-00	657	666397	747	69100-40820	715	69140-43B10	649
5VX-W0045-00	691	666574	142	69100-40840	715	69140-43D00	648
5VX-W0046-00	657	666935	159	69100-43820	648	69301-H08-100	747
5VY-W0045-00	634	668017	177	69100-43840	648	69400-37820	604
5WX-W0045-00	774	668021	187	69100-43850	648	7-020-016	638
5WX-W0045-10	559	67131-5EE0-0000	544	69100-44860	635	7-020-022	848
5XC-W0045-00	840	67131-BCAO-0000	638	69100-45890	620	7030-081420	611
5XT-W0045-00	728	690-13-030-000	841	69100-47820	834	7030-081520	546
5XT-W0046-50	632	690-13-090-000	730	69100-47830	834	7030-0853A0	638
5YU-W0046-00	654	690-13-190-000	730	69100-48810	577	7030-0855A0	546
600-13-030-000	674	69095	604	69100-48820	881	7040	803
603-13-130-000	706	69096	604	69101-03810	754	705-600-004	767
6050-080180	713	69096-05	790	69101-03820	835	705-600-014	754
605-08-02-50	575	69100-01810	649	69101-05820	556	705-600-150	767
606-08-02-70	730	69100-01880	886	69101-44810	833	705-600-285	544
610113-497417	544	69100-02821	544	69101-44850	881	705-600-349	754
610143	544	69100-03840	767	69101-44890	833	705-600-350	767
610164810	915	69100-03880	820	69101-45820	512	705-600-398	754

OE No.	SBS No.	OE No.	SBS No.	OE No.	SBS No.	OE No.	SBS No.
705600485	908	800094024	676	8133761	159	9060-080910	611
705600-711	908	800094411	566	8133798	588	9100788	694
705601014	910	8000-95280	730	8133815	159	9100797	790
705601015	911	8000-95542	706	8133906	674	99-2769	523
705601149	971	80009634	671	8133943	844	A000-0801A0	705
705601150	972	80009870	676	8213051	574	A000-0801B0	704
715500325	638	8000A2790	791	8213104	574	A000-0802B0	687
715500336	611	8000A7143	671	8213-145	607	A45120-168-000	633
71550036	611	8000A9231	675	821-3145	607	AB024	671
71550335	638	8000B1421	805	821-3197	519	AB024-S	671
715900379	957	8000B1601	841	821-3200	519	AB040	675
715900380	956	8000B1663	841	8213460	153	AB040-S	675
715900386	957	8000B5975	730	8213462	153	ABH-W0045-01	682
715900387	956	8000H4667	794	8213506	747	AM140607	912
736502	544	8000H7132	783	8213577	747	AP8113627	674
737786	559	8000H7138	872	8213648	159	B044201	566
745658	773	802-567-1000	619	830-13-030-100	866	B044202	566
750-13-030-000	706	803.08.01.60	663	830-13-090-100	867	B044223	544
75013090000	675	803138	716	8532279	674	B044224	544
750-13-090-000	675	8044220	821	8537246	706	B22-45230-0000	730
752426	544	8044221	585	8537251	841	B23-45280-0000	747
752816	559	8044601	900	8538735	841	B29-25805-00	840
752817	607	810183	638	860883	671	B2W-25805-00	965
752818	544	8103662	519	862489	730	B5H-25805-00-00	979
753092	559	810K0209	803	862698	730	B5H-25806-00-00	980
753200	559	810K5804	821	862900	773	B74074-100000	848
754605	774	811-3016	519	864121	585	B840C34	878
754804	614	811-3064	519	864342	859	B840F64-6500000	810
754808	722	8113104	574	864428	585	B840F6600000	717
755981-1160	773	811-3118	519	864580	821	BAS-25806-00	584
7-5-601-147	767	8113181	559	865527	859	BC-2500-22065	694
756020	774	811-3196	519	866687	821	BD5-25806-00	991
757215	559	811-3222	519	866692	585	BE250022065	694
7588626	773	811-3283	641	883673	706	BE-2500-22065	694
76513030000	675	811-3323	519	8900239	792	BE2500-22068	604
770-13-020-000	671	81133603	159	8900539	749	BE250122065SM	566
777-13-030-000	671	8113373	652	890304	546	BE-675002509	790
786764	716	811-3375	651	894047	671	BQ300222065	671
8000-29070	519	8113431	588	894051	585	BQ300222068	671
8000-33545	574	8113478	774	897118	844	BT-27922065	815
8000-37009	574	8113489	601	8A00-461-47	519	BT-280022065	815
8000-39730	519	8113523	774	8A0074181	671	BT280222068	803
8000-45453	594	8113533	674	8A0079072	675	BT-6000063012	885
8000-46147	519	8113538	675	8B0074181	671	BT62500GG	963
8000-461-47	519	8113585	566	8C0074181	671	BT65003013	939
8000-59214	641	8113593	671	9010-080510	799	C389	802
800059869	588	8113595	684	9010-0805A0	799	C390	803
8000-60195	692	8113604	652	9010-0805B0	799	CP42264	719
8000-66785	633	8113627	674	9010-0808B0	914	CP6688D29	805
8000-66796	647	811-3638	519	901-08-03-22	717	D06-45230-00-00	559
800066937	672	811-3651	519	901-08-05-01	799	EJ29099074	559
8000-68794	684	811-3662	519	901-08-05-10	799	F000P02030	671
800070854	536	8113720	706	901-08-08-01	914	FZ10176	810
800070858	611	8113751	730	901-08-08-10	914	G71315EE00000	544
800070888	611	8113754	706	901-13-030-000	877	G7131-LRAO-000	847
800071450	611	8113865	588	9021035000	519	GA121001T	559
800071451	592	811-3869	747	9021038000	519	GF5359902	544
800078331	566	8113898	730	90210-55000	566	GU01654630	706
8000-78331	566	8113988	674	90214-01000	601	GU03654600	674
800079072	675	812111	847	9022001000	681	GU05654630	671
800081593	706	812732	559	902203-100	684	GU27654610	519
8000-82748	763	8133516	671	902-300-1000	688	GU30654600	566
800086714	706	8133539	747	902-3002000	713	GU30654602	566
8000-88482	627	8133540	588	9024020000	624	GU30654626	674
800088725	588	8133542	730	9024030000	715	GU30654630	641
8000-88725	588	8133614	706	903-08-08-70	611	GU30654631	601
8000-88772	706	8133724	588	903-08-08-80	611	GU30654675	671
800089025	900	8133725	588	903-08-08-90	638	GU31654681	730
8000-901-56	519	8133726	747	9060-080810	638	GU32654610	706

OE No.	SBS No.	OE No.	SBS No.	OE No.	SBS No.	OE No.	SBS No.
GV18654660	554	R290063110000	774				
H0300-2AB	795	R30000126000	706				
H0300F	676	R351	652				
H0300T	654	R43440-311A0	774				
H0300-T	627	R44422001A	730				
IC000760	859	R44440-161A0	747				
IC000818	224	R44440181A0	772				
IC3-W0046-10	790	R800277	544				
IC3-W0046-50	790	R800278	713				
ID9-W0046-00	754	RO50371008000	713				
IS3-W0045-00	611	S10B-40202-00-00	803				
IS3-W0046-10	638	S11D-40202-00	773				
ISC-F5805-00	544	S4311-ARCA000	810				
ISR29-002	655	S4511-ARCA000	810				
K00946315	608	SBR-F5811-00	145				
K00976315	774	SBR-FS811-10	145				
K01303070	773	SEA-W0046-50	733				
K01306075	777	SFL-W0046-50	733				
K01309079	774	SGR-W0046-00	604				
K01310073	585	SM-27300	843				
K4308-0006	790	SVH-W0045-00	691				
K4308-211-96	726	SVU-W0045-10	691				
K4308-21203	704	T01H000101	619				
K4308-21204	546	T-2020071-T301	611				
K4308-21205	592	T-2020072-T301	638				
K4308-21225	694	T2020077	654				
K4308-21241	536	T2020193	624				
K4308-21242	752	T2020194	654				
K4308-21274	686	T2020211	683				
K4308-21286	694	T2020218	683				
KA3495506	575	T2020221	683				
KA3496535	519	T2020245	624				
KA3497506	651	T2020246	624				
KM0961320	803	T-2020-329	782				
M028Z04	711	T2020393	624				
M049Z04	805	T2020475	782				
M1300001500	730	T2020537	654				
M13400001400	706	T2020543	627				
M13400004400	730	T2020553	624				
M1340001400	674	T2020602	614				
M497Z04	841	T2020848	674				
M9467Z04	671	T2021221	864				
N50025061	566	T2021451	841				
P00-927-020-64-07-000	652	T2021541	841				
P150442	559	T2022475	713				
P4064905001002640	551	T2025016	614				
P67660000116700	551	T2025045	713				
PE-745658	773	T2027535	627				
PE756676	142	T2027545	627				
PE757231	774	T2027820	841				
PE757243	142	VGA-12182	908				
PE-758935	713	VGA-12183	908				
PE774896	536	YOOFA1409	708				
PE776-170	551	Z150-9261	908				
PE776171	730						
PE801968	708						
PE-802219	142						
PE-802275	713						
PE802452	544						
PE802576	688						
PE8033443	205						
PE803444	546						
PS-2012-02001	544						
QCA0648860010	544						
R050371008000	774						
R050372080000	747						
R1700-7208-0000	713						
R180100127000	730						
R235000	559						

ALMOST ANY BIKE  
BRAKE PADS, CLUTCH KITS AND BRAKE ROTORS

Find the right part with  
the PRODUCT SELECTOR  
at SBSBRAKES.COM

**sbs**<sup>®</sup>  
GO AHEAD



HI-TECH BRAKE SOLUTIONS  
MADE IN EUROPE

Find the right brake pads, discs or clutches for your bike

Select the fields in any order

Brand\*  CC\*  Model\*  Year\*

SHOW MATCHES >

NEW SEARCH





@sbsbrakes | sbsbrakes.com | #GoAhead

# **BRAKE PINS**

## **FITMENTS, DRAWINGS**



			Complete set		
<b>HONDA</b>					
CR	125 R	98 - 01	4000	4506	4505
CR	125 R	02 - 07	4001	4506	4508
CR	250 R	95 - 01	4000	4506	4505
CR	250 R	02 - 07	4001	4506	4508
CRF	250 R	04 - 20	4001	4506	4508
CRF	250 X	04 - 14	4001	4506	4508
CRF	450 R	02 - 18	4003	4507	4510
CRF	450 RX	17 - 18	4004	4505	4505
CRF	450 X	05 - 18	4001	4506	4508
<b>HUSQVARNA</b>					
CR	125	05 - 13	4003	4507	4510
TC	125	14 - 18	4003	4507	4510
TE	125	14 - 16	4003	4507	4510
TX	125	17 - 18	4004	4505	4505
CR	250	05 - 05	4003	4507	4510
FC	250	14 - 18	4003	4507	4510
FE	250	14 - 18	4003	4507	4510
TC	250	04 - 18	4003	4507	4510
TE	250	02 - 18	4003	4507	4510
TE	300	14 - 18	4003	4507	4510
FC	350	14 - 18	4003	4507	4510
FE	350	14 - 18	4003	4507	4510
TC	449	11 - 13	4003	4507	4510
FC	450	14 - 18	4003	4507	4510
FE	450	14 - 18	4003	4507	4510
TE	450	14 - 14	4003	4507	4510
FE	501	14 - 18	4003	4507	4510
TE	511	11 - 13	4003	4507	4510
<b>KAWASAKI</b>					
KX	125	95 - 96	4000	4506	4505
KX	125	97 - 08	4002	4509	4505
KX	250	95 - 96	4000	4506	4505
KX	250	97 - 08	4002	4509	4505
KX	250 F	04 - 18	4003	4507	4510
KX	450 F	06 - 18	4003	4507	4510
<b>KTM</b>					
EXC	125 Enduro	04 - 15	4003	4507	4510
SX	125	00 - 18	4003	4507	4510
SX	144	07 - 08	4003	4507	4510
SX	150	09 - 18	4003	4507	4510
EXC	200 Enduro	04 - 16	4003	4507	4510
SX	200	03 - 04	4003	4507	4510
EXC	250 Enduro	04 - 08	4003	4507	4510
EXC	250 Enduro 4T	04 - 06	4002	4509	4505
EXC	250 TPI	18 - 18	4004	4505	4505
EXC-F	250	07 - 18	4003	4507	4510
SX	250	03 - 18	4003	4507	4510
SX-F	250	06 - 18	4003	4507	4510
XC	250	06 - 14	4003	4507	4510
EXC	300 Enduro	04 - 08	4003	4507	4510
EXC	300 TPI	18 - 18	4004	4505	4505
XC	300	06 - 14	4003	4507	4510
EXC-F	350	11 - 18	4003	4507	4510
SX-F	350	11 - 18	4003	4507	4510
EXC	400 Racing	00 - 07	4003	4507	4510
SX	400 Racing	00 - 02	4000	4506	4505
EXC-F	450	04 - 18	4003	4507	4510
SX-F	450	03 - 18	4003	4507	4510
XC-F	450	06 - 19	4003	4507	4510
EXC-F	500	12 - 18	4003	4507	4510
XC-F	505	08 - 09	4003	4507	4510
EXC	520 Racing	00 - 02	4000	4506	4505
SX-F	520 Racing	00 - 02	4000	4506	4505
EXC	525 Racing	03 - 06	4003	4507	4510
SX-F	525 Racing	03 - 06	4003	4507	4510





## SBS 4000



HONDA				
CR	125 R	98 - 01	•	
CR	250 R	95 - 01	•	
KAWASAKI				
KX	125	95 - 96	•	
KX	250	95 - 96	•	
SUZUKI				
RM	125	99 - 04	•	
RM	250	99 - 04	•	
RM-Z	250	07 - 07	•	
RM-Z	450	05 - 07	•	
YAMAHA				
YZ	85 , LW	10 - 19	•	
YZ	125	98 - 18	•	
WR	250 F	03 - 13	•	
YZ	250	98 - 18	•	
YZ	250 F	01 - 18	•	
YZ	250 FX	15 - 15	•	
YZ	400 F	98 - 98	•	
YZ	426 F	00 - 02	•	
WR	450 F	03 - 15	•	
WR	450 F Efi	16 - 18	•	
YZ	450 F	03 - 09	•	



## SBS 4001



HONDA				
CR	125 R	02 - 07	•	
CR	250 R	02 - 07	•	
CRF	250 R	04 - 20	•	
CRF	250 X	04 - 14	•	
CRF	450 X	05 - 18	•	
SUZUKI				
RM	125	05 - 09	•	
RM	250	05 - 09	•	
RM-Z	250	08 - 18	•	
RM-Z	450	08 - 18	•	



 SBS 4509  SBS 4505



**KAWASAKI**

KX	125	97 - 08	•		
KX	250	97 - 08	•		

**SUZUKI**

RM-Z	250	04 - 06	•		
------	-----	---------	---	--	--

 SBS 4507  SBS 4510



**HUSQVARNA**

CR	125	05 - 13	•		
TC	125	14 - 18	•		
TE	125	14 - 16	•		
CR	250	05 - 05	•		
FC	250	14 - 18	•		
FE	250	14 - 18	•		
TC	250	04 - 18	•		
TE	250	02 - 18	•		
TE	300	14 - 18	•		
FC	350	14 - 18	•		
FE	350	14 - 18	•		
TC	449	11 - 13	•		
FC	450	14 - 18	•		
FE	450	14 - 18	•		
TE	450	14 - 14	•		
FE	501	14 - 18	•		
TE	511	11 - 13	•		

**KTM**

EXC	125 Enduro	04 - 15	•		
SX	125	00 - 18	•		
SX	144	07 - 08	•		
SX	150	09 - 18	•		
EXC	200 Enduro	04 - 16	•		
SX	200	03 - 04	•		
EXC	250 Enduro	04 - 08	•		
EXC-F	250	07 - 18	•		
SX	250	03 - 18	•		
SX-F	250	06 - 18	•		
XC	250	06 - 14	•		
EXC	300 Enduro	04 - 08	•		
XC	300	06 - 14	•		
EXC-F	350	11 - 18	•		
SX-F	350	11 - 18	•		
EXC	400 Racing	00 - 07	•		
EXC-F	450	04 - 18	•		
SX-F	450	03 - 18	•		
XC-F	450	06 - 19	•		
EXC-F	500	12 - 18	•		
XC-F	505	08 - 09	•		
EXC	525 Racing	03 - 06	•		
SX-F	525 Racing	03 - 06	•		



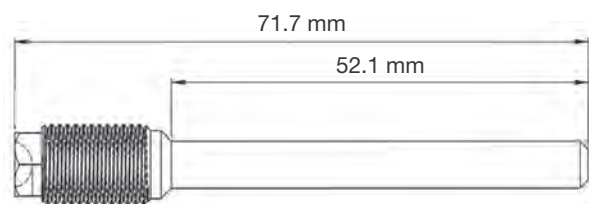

**YAMAHA**

YZ	85 , LW	10 - 19			•
YZ	125	98 - 18			•
WR	250 F	03 - 13			•
WR	250 F Efi	17 - 18		•	•
WR	250 F Enduro GP	18 - 18		•	•
WR	250 X	08 - 16		•	•
YZ	250	98 - 18			•
YZ	250 F	01 - 18			•
YZ	250 FX	15 - 15			•
YZ	400 F	98 - 98			•
YZ	426 F	00 - 02			•
WR	450 F	03 - 15			•
WR	450 F Efi	16 - 18			•
WR	450 F Enduro GP	18 - 18		•	•
YZ	450 F	03 - 09			•

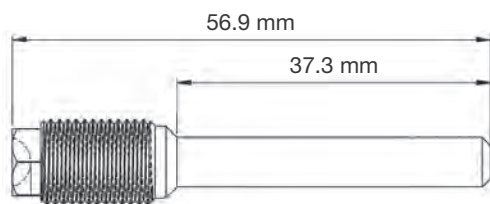

**HONDA**

CR	125 R	98 - 01			•
CR	125 R	02 - 07			•
CR	250 R	95 - 01			•
CR	250 R	02 - 07			•
CRF	250 R	04 - 20			•
CRF	250 X	04 - 14			•
CRF	450 X	05 - 18			•

**KAWASAKI**

KX	125	95 - 96			•
KX	250	95 - 96			•

**SUZUKI**

RM	125	99 - 04			•
RM	125	05 - 09			•
RM	250	99 - 04			•
RM	250	05 - 09			•
RM-Z	250	07 - 07			•
RM-Z	250	08 - 18			•
RM-Z	450	05 - 07			•
RM-Z	450	08 - 18			•

**YAMAHA**

YZ	85 , LW	10 - 19			•
YZ	125	98 - 18			•
WR	250 F	03 - 13			•
YZ	250	98 - 18			•
YZ	250 F	01 - 18			•
YZ	250 FX	15 - 15			•
YZ	400 F	98 - 98			•
YZ	426 F	00 - 02			•
WR	450 F	03 - 15			•
WR	450 F Efi	16 - 18			•
YZ	450 F	03 - 09			•



**HUSQVARNA**

CR	125	05 - 13	•
TC	125	14 - 18	•
TE	125	14 - 16	•
CR	250	05 - 05	•
FC	250	14 - 18	•
FE	250	14 - 18	•
TC	250	04 - 18	•
TE	250	02 - 18	•
TE	300	14 - 18	•
FC	350	14 - 18	•
FE	350	14 - 18	•
TC	449	11 - 13	•
FC	450	14 - 18	•
FE	450	14 - 18	•
TE	450	14 - 14	•
FE	501	14 - 18	•
TE	511	11 - 13	•

**KTM**

EXC	125 Enduro	04 - 15	•
SX	125	00 - 18	•
SX	144	07 - 08	•
SX	150	09 - 18	•
EXC	200 Enduro	04 - 16	•
SX	200	03 - 04	•
EXC	250 Enduro	04 - 08	•
EXC-F	250	07 - 18	•
SX	250	03 - 18	•
SX-F	250	06 - 18	•
XC	250	06 - 14	•
EXC	300 Enduro	04 - 08	•
XC	300	06 - 14	•
EXC-F	350	11 - 18	•
SX-F	350	11 - 18	•
EXC	400 Racing	00 - 07	•
EXC-F	450	04 - 18	•
SX-F	450	03 - 18	•
XC-F	450	06 - 19	•
EXC-F	500	12 - 18	•
XC-F	505	08 - 09	•
EXC	525 Racing	03 - 06	•
SX-F	525 Racing	03 - 06	•
EXC	530 Racing	08 - 11	•

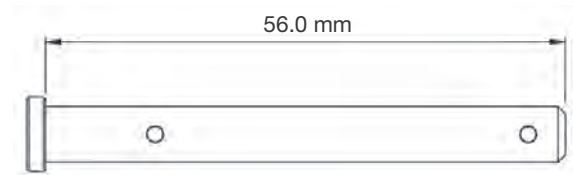

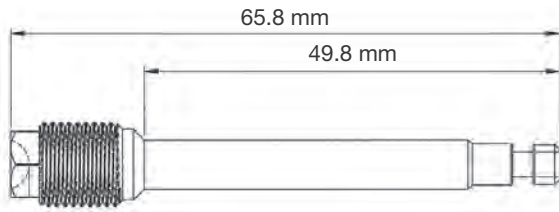

**HONDA**

CR	125 R	02 - 07			•
CR	250 R	02 - 07			•
CRF	250 R	04 - 20			•
CRF	250 X	04 - 14			•
CRF	450 X	05 - 18			•

**SUZUKI**

RM	125	05 - 09			•
RM	250	05 - 09			•
RM-Z	250	08 - 18			•
RM-Z	450	08 - 18			•

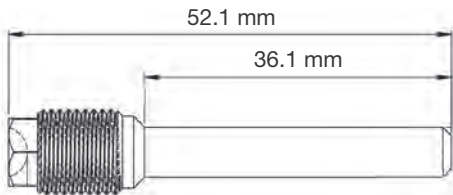

**KAWASAKI**

KX	125	97 - 08			•
KX	250	97 - 08			•

**SUZUKI**

RM-Z	250	04 - 06			•
------	-----	---------	--	--	---



























# CHOICE OF WORLD CHAMPION

# 2021

World SSP600 Championship

## #77 Dominique Aegerter

Ten Kate Yamaha Racing



*D. Aegerter*  
#77



PHOTO: GeeBee Images



SBS 634 DS-1 & SBS 966 DS-1  
DUAL SINTER



SBS 834 RQ  
CARBON TECH



HI-TECH BRAKE SOLUTIONS  
MADE IN EUROPE



# HI-TECH BRAKE SOLUTIONS MADE IN EUROPE

At SBS, we develop and manufacture hi-tech brake solutions.

Our ranges of brake pads, brake rotors, brake shoes, clutch kits and other important parts cover all relevant motorcycles, scooters and ATV/UTVs on the market, regardless of make and model. SBS is your single source for brake parts and components.

We are a global market leader within brakes for powered two-wheelers. Our R&D department continuously innovates with new materials and technologies to achieve ultimate performance, longer lifetime, higher comfort and more eco-friendly products.

Our products are tested by reality. Dynamometer testing is supplemented with numerous street and race track tests. We work with some of the world's best road racing and motocross riders, when they race towards podium positions.

We create the power to stop you. Made in Europe. You decide where and how to use it. Go Ahead!

